

# HD74LV1GW98A

## Configurable Multiple-Function Gate

REJ03D0084-0200Z

Rev.2.00

Mar.11.2004

### Description

The HD74LV1GW98A has configurable multiple-function gate in a 6 pin package. The Output state is determined by eight patterns of 3-bit input. The user can choose the logic functions AND, NAND, OR, NOR, INVERTER, Non-Inverted Buffer, Data Selector. Low voltage and high-speed operation is suitable for the battery powered products (e.g., notebook computers), and the low power consumption extends the battery life.

### Features

- The basic gate function is lined up as Renesas uni logic series.
- Supplied on emboss taping for high-speed automatic mounting.
- Supply voltage range : 1.65 to 5.5 V  
Operating temperature range : -40 to +85°C
- All inputs  $V_{IH}$  (Max.) = 5.5 V (@ $V_{CC}$  = 0 V to 5.5 V)  
All outputs  $V_O$  (Max.) = 5.5 V (@ $V_{CC}$  = 0 V)
- Output current  $\pm 6$  mA (@ $V_{CC}$  = 3.0 V to 3.6 V),  $\pm 12$  mA (@ $V_{CC}$  = 4.5 V to 5.5 V)
- All the logical input has hysteresis voltage for the slow transition.
- Ordering Information

| Part Name       | Package Type | Package Code | Package Abbreviation | Taping Abbreviation (Quantity) |
|-----------------|--------------|--------------|----------------------|--------------------------------|
| HD74LV1GW98ACME | CMPAK-6 pin  | CMPAK-6V(O)  | CM                   | E (3,000 pcs / Reel)           |

### Outline and Article Indication

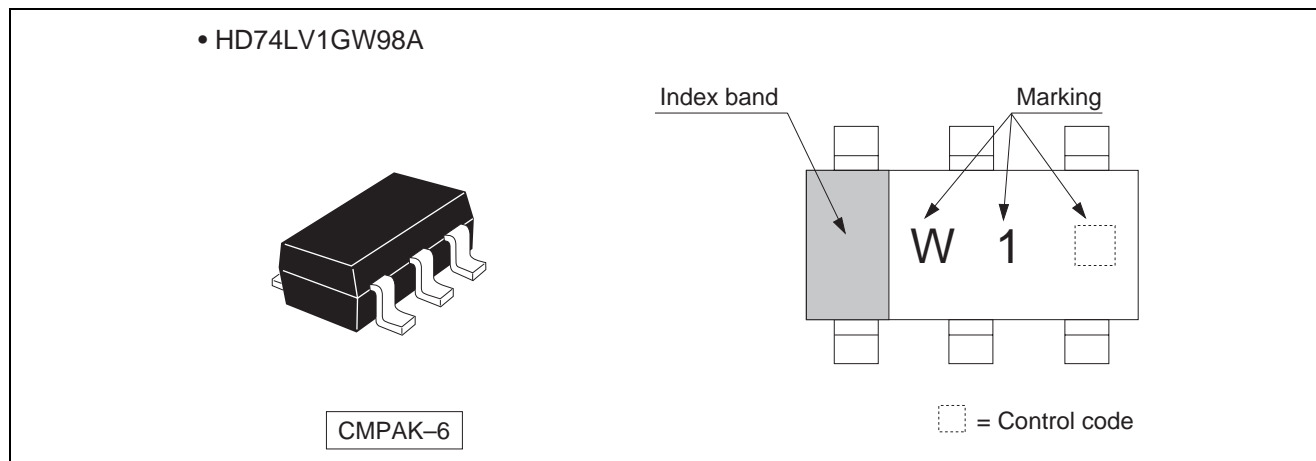

**Function Table**

| Inputs |     |     | Output |
|--------|-----|-----|--------|
| IN2    | IN1 | IN0 | Y      |
| L      | L   | L   | H      |
| L      | L   | H   | H      |
| L      | H   | L   | L      |
| L      | H   | H   | L      |
| H      | L   | L   | H      |
| H      | L   | H   | L      |
| H      | H   | L   | H      |
| H      | H   | H   | L      |

H : High level

L : Low level

**Pin Arrangement**

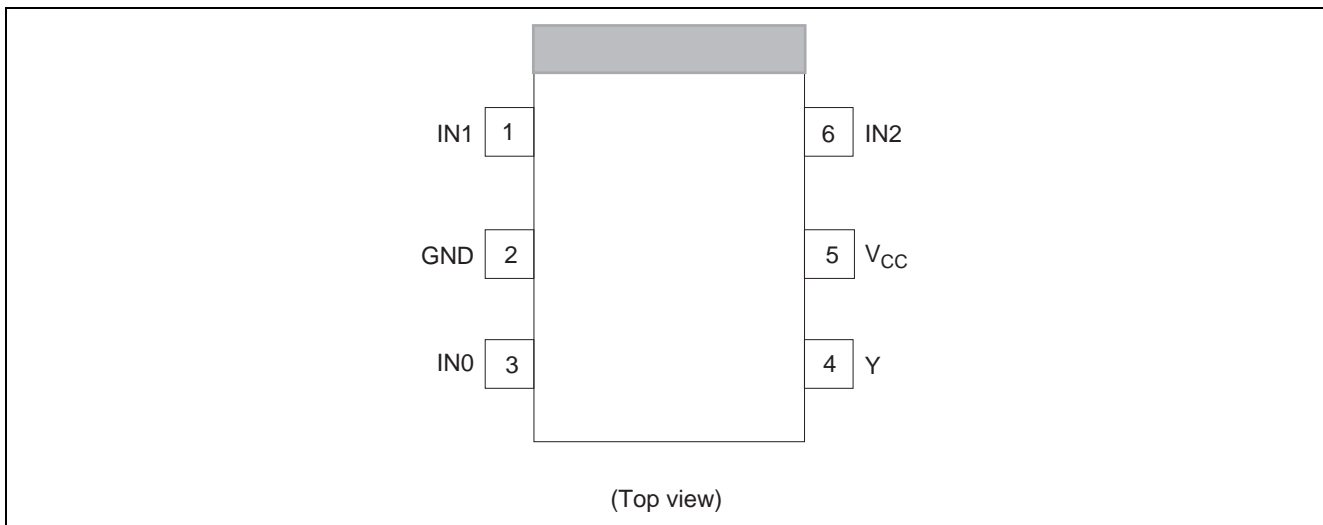

**Logic Diagram**

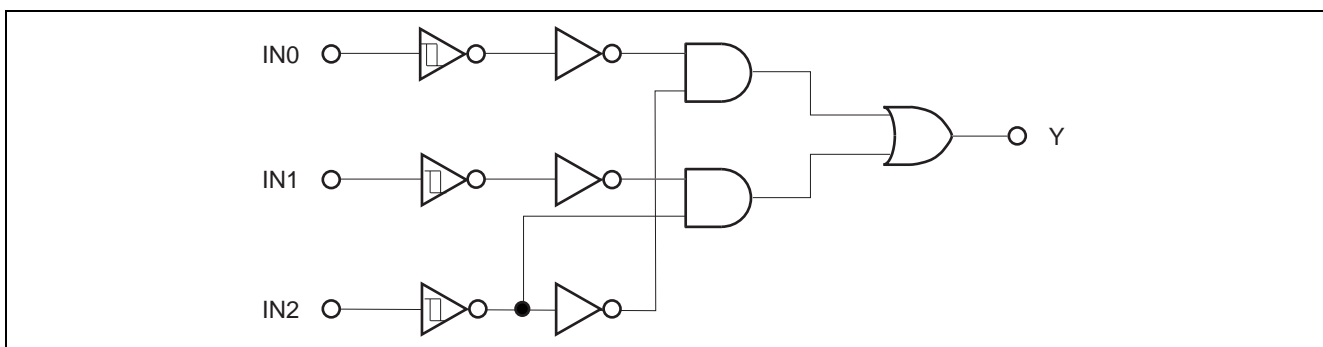

**Function Selection Table**

| <b>Logic Function</b>                 | <b>Figure No.</b> |
|---------------------------------------|-------------------|
| 2 to 1 data Selector                  | 1                 |
| 2-inputs NAND                         | 2                 |
| 2-inputs NOR with one input inverted  | 3                 |
| 2-inputs AND with one input inverted  | 3                 |
| 2-inputs NAND with one input inverted | 4                 |
| 2-inputs OR with one input inverted   | 4                 |
| 2-inputs NOR                          | 5                 |
| Non-Invert Buffer                     | 6                 |
| Inverter                              | 7                 |

Logic Configurations

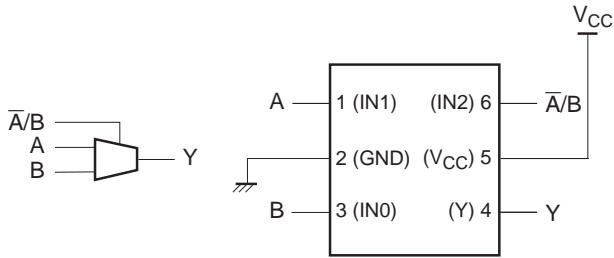

Figure 1. 2 to 1 Data Selector

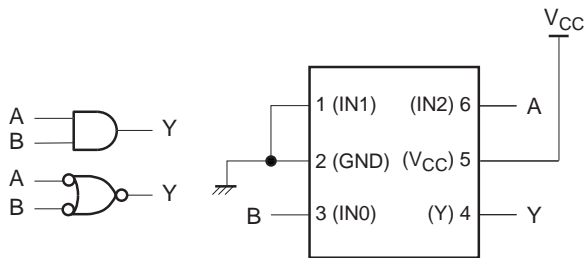

Figure 2. 2-inputs AND Gate

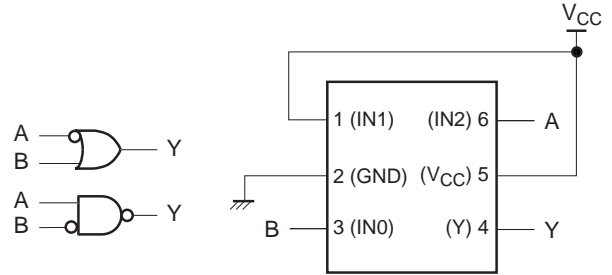

Figure 3. 2-inputs OR Gate with A input inverted

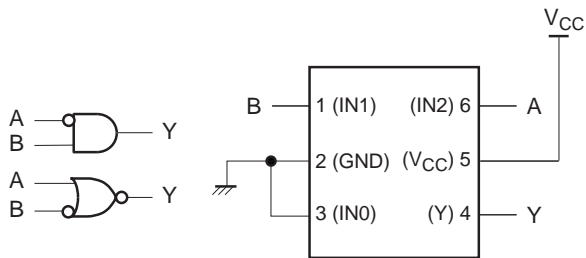

Figure 4. 2-inputs AND Gate with A input inverted

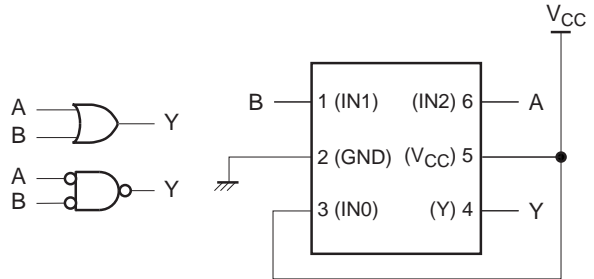

Figure 5. 2-inputs OR Gate

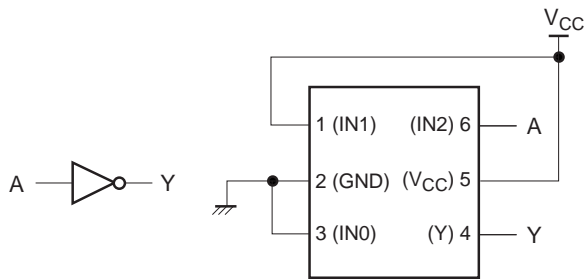

Figure 6. Inverter

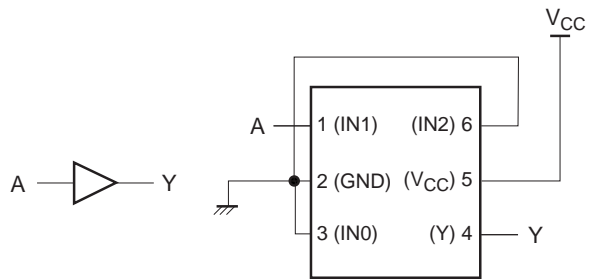

Figure 7. Non-Invert Buffer

**Absolute Maximum Ratings**

| Item   | Symbol                | Ratings                               | Unit             | Test Conditions                   |
|--|-----------------------|---------------------------------------|------------------|-----------------------------------|
| Supply voltage range   | $V_{CC}$              | -0.5 to 7.0                           | V                |                                   |
| Input voltage range <sup>*1</sup>  | $V_I$                 | -0.5 to 7.0                           | V                |                                   |
| Output voltage range <sup>*1, 2</sup>  | $V_O$                 | -0.5 to $V_{CC} + 0.5$<br>-0.5 to 7.0 | V                | Output : H or L<br>$V_{CC}$ : OFF |
| Input clamp current  | $I_{IK}$              | -20                                   | mA               | $V_I < 0$                         |
| Output clamp current   | $I_{OK}$              | $\pm 50$                              | mA               | $V_O < 0$ or $V_O > V_{CC}$       |
| Continuous output current  | $I_O$                 | $\pm 25$                              | mA               | $V_O = 0$ to $V_{CC}$             |
| Continuous current through $V_{CC}$ or GND   | $I_{CC}$ or $I_{GND}$ | $\pm 50$                              | mA               |                                   |
| Maximum power dissipation at $T_a = 25^\circ\text{C}$ (in still air) <sup>*3</sup> | $P_T$                 | 200                                   | mW               |                                   |
| Storage temperature  | $T_{stg}$             | -65 to 150                            | $^\circ\text{C}$ |                                   |

Notes: The absolute maximum ratings are values, which must not individually be exceeded, and furthermore no two of which may be realized at the same time.

1. The input and output voltage ratings may be exceeded if the input and output clamp-current ratings are observed.
2. This value is limited to 5.5 V maximum.
3. The maximum package power dissipation was calculated using a junction temperature of  $150^\circ\text{C}$ .

**Recommended Operating Conditions**

| Item                               | Symbol                | Min  | Max      | Unit             | Conditions                  |
|------------------------------------|-----------------------|------|----------|------------------|-----------------------------|
| Supply voltage range               | $V_{CC}$              | 1.65 | 5.5      | V                |                             |
| Input voltage range                | $V_I$                 | 0    | 5.5      | V                |                             |
| Output voltage range               | $V_O$                 | 0    | $V_{CC}$ | V                |                             |
| Output current                     | $I_{OL}$              | —    | 1        | mA               | $V_{CC} = 1.65$ to $1.95$ V |
|                                    |                       | —    | 2        |                  | $V_{CC} = 2.3$ to $2.7$ V   |
|                                    |                       | —    | 6        |                  | $V_{CC} = 3.0$ to $3.6$ V   |
|                                    |                       | —    | 12       |                  | $V_{CC} = 4.5$ to $5.5$ V   |
|                                    | $I_{OH}$              | —    | -1       |                  | $V_{CC} = 1.65$ to $1.95$ V |
|                                    |                       | —    | -2       |                  | $V_{CC} = 2.3$ to $2.7$ V   |
|                                    |                       | —    | -6       |                  | $V_{CC} = 3.0$ to $3.6$ V   |
|                                    |                       | —    | -12      |                  | $V_{CC} = 4.5$ to $5.5$ V   |
| Input transition rise or fall rate | $\Delta t / \Delta v$ | 0    | 300      | ns / V           | $V_{CC} = 1.65$ to $1.95$ V |
|                                    |                       | 0    | 200      |                  | $V_{CC} = 2.3$ to $2.7$ V   |
|                                    |                       | 0    | 100      |                  | $V_{CC} = 3.0$ to $3.6$ V   |
|                                    |                       | 0    | 20       |                  | $V_{CC} = 4.5$ to $5.5$ V   |
| Operating free-air temperature     | $T_a$                 | -40  | 85       | $^\circ\text{C}$ |                             |

Note: Unused or floating inputs must be held high or low.

Electrical Characteristics

Ta = -40 to 85°C

| Item              | Symbol                      | V <sub>CC</sub> (V) | Min                   | Typ | Max                   | Unit | Test condition           |    |  |
|-------------------|-----------------------------|---------------------|-----------------------|-----|-----------------------|------|--------------------------|----|--|
| Threshold voltage | V <sub>T</sub> <sup>+</sup> | 1.65 to 1.95        | —                     | —   | V <sub>CC</sub> ×0.75 | V    |                          |    |  |
|                   |                             | 2.5                 | —                     | —   | 1.75                  |      |                          |    |  |
|                   |                             | 3.3                 | —                     | —   | 2.31                  |      |                          |    |  |
|                   |                             | 5.0                 | —                     | —   | 3.50                  |      |                          |    |  |
|                   | V <sub>T</sub> <sup>-</sup> | 1.65 to 1.95        | V <sub>CC</sub> ×0.25 | —   | —                     |      |                          |    |  |
|                   |                             | 2.5                 | 0.75                  | —   | —                     |      |                          |    |  |
|                   |                             | 3.3                 | 0.99                  | —   | —                     |      |                          |    |  |
|                   |                             | 5.0                 | 1.5                   | —   | —                     |      |                          |    |  |
|                   | ΔV <sub>T</sub>             | 1.65 to 1.95        | 0.1                   | —   | V <sub>CC</sub> ×0.4  |      |                          |    |  |
|                   |                             | 2.5                 | 0.25                  | —   | 1.0                   |      |                          |    |  |
|                   |                             | 3.3                 | 0.33                  | —   | 1.32                  |      |                          |    |  |
|                   |                             | 5.0                 | 0.5                   | —   | 2.0                   |      |                          |    |  |
| Output voltage    | V <sub>OH</sub>             | Min to Max          | V <sub>CC</sub> -0.1  | —   | —                     | V    | I <sub>OH</sub> = -50 μA |    |  |
|                   |                             | 1.65                | 1.4                   | —   | —                     |      | I <sub>OH</sub> = -1 mA  |    |  |
|                   |                             | 2.3                 | 2.0                   | —   | —                     |      | I <sub>OH</sub> = -2 mA  |    |  |
|                   |                             | 3.0                 | 2.48                  | —   | —                     |      | I <sub>OH</sub> = -6 mA  |    |  |
|                   |                             | 4.5                 | 3.8                   | —   | —                     |      | I <sub>OH</sub> = -12 mA |    |  |
|                   | V <sub>OL</sub>             | Min to Max          | —                     | —   | 0.1                   |      | I <sub>OL</sub> = 50 μA  |    |  |
|                   |                             | 1.65                | —                     | —   | 0.3                   |      | I <sub>OL</sub> = 1 mA   |    |  |
|                   |                             | 2.3                 | —                     | —   | 0.4                   |      | I <sub>OL</sub> = 2 mA   |    |  |
|                   |                             | 3.0                 | —                     | —   | 0.44                  |      | I <sub>OL</sub> = 6 mA   |    |  |
|                   |                             | 4.5                 | —                     | —   | 0.55                  |      | I <sub>OL</sub> = 12 mA  |    |  |
|                   | Input current               | I <sub>IN</sub>     | 0 to 5.5              | —   | —                     |      | ±1                       | μA | V <sub>IN</sub> = 5.5 V or GND                               |
|                   | Quiescent supply current    | I <sub>CC</sub>     | 5.5                   | —   | —                     |      | 10                       | μA | V <sub>IN</sub> = V <sub>CC</sub> or GND, I <sub>O</sub> = 0 |
|                   | Output leakage current      | I <sub>OFF</sub>    | 0                     | —   | —                     |      | 5                        | μA | V <sub>IN</sub> or V <sub>O</sub> = 0 to 5.5 V               |
|                   | Input capacitance           | C <sub>IN</sub>     | 3.3                   | —   | 3.0                   |      | —                        | pF | V <sub>IN</sub> = V <sub>CC</sub> or GND                     |

Note: For conditions shown as Min or Max, use the appropriate values under recommended operating conditions.

Switching Characteristics

$V_{CC} = 1.8 \pm 0.15 \text{ V}$

| Item                   | Symbol           | Ta = 25°C |      |      | Ta = -40 to 85°C |      | Unit | Test Conditions                                  | FROM (Input) | TO (Output) |
|------------------------|------------------|-----------|------|------|------------------|------|------|--|--------------|-------------|
|                        |                  | Min       | Typ  | Max  | Min              | Max  |      |  |              |             |
| Propagation delay time | t <sub>PLH</sub> | —         | 15.8 | 29.4 | 1.0              | 33.0 | ns   | C <sub>L</sub> = 15 pF<br>C <sub>L</sub> = 50 pF | IN           | Y           |
|                        | t <sub>PHL</sub> | —         | 22.6 | 40.9 | 1.0              | 45.0 |      |  |              |             |

$V_{CC} = 2.5 \pm 0.2 \text{ V}$

| Item                   | Symbol           | Ta = 25°C |      |      | Ta = -40 to 85°C |      | Unit | Test Conditions                                  | FROM (Input) | TO (Output) |
|------------------------|------------------|-----------|------|------|------------------|------|------|--|--------------|-------------|
|                        |                  | Min       | Typ  | Max  | Min              | Max  |      |  |              |             |
| Propagation delay time | t <sub>PLH</sub> | —         | 9.4  | 17.6 | 1.0              | 21.0 | ns   | C <sub>L</sub> = 15 pF<br>C <sub>L</sub> = 50 pF | IN           | Y           |
|                        | t <sub>PHL</sub> | —         | 12.6 | 22.6 | 1.0              | 26.5 |      |  |              |             |

$V_{CC} = 3.3 \pm 0.3 \text{ V}$

| Item                   | Symbol           | Ta = 25°C |     |      | Ta = -40 to 85°C |      | Unit | Test Conditions                                  | FROM (Input) | TO (Output) |
|------------------------|------------------|-----------|-----|------|------------------|------|------|--|--------------|-------------|
|                        |                  | Min       | Typ | Max  | Min              | Max  |      |  |              |             |
| Propagation delay time | t <sub>PLH</sub> | —         | 7.0 | 11.0 | 1.0              | 13.0 | ns   | C <sub>L</sub> = 15 pF<br>C <sub>L</sub> = 50 pF | IN           | Y           |
|                        | t <sub>PHL</sub> | —         | 9.5 | 14.5 | 1.0              | 16.5 |      |  |              |             |

$V_{CC} = 5.0 \pm 0.5 \text{ V}$

| Item                   | Symbol           | Ta = 25°C |     |     | Ta = -40 to 85°C |      | Unit | Test Conditions                                  | FROM (Input) | TO (Output) |
|------------------------|------------------|-----------|-----|-----|------------------|------|------|--|--------------|-------------|
|                        |                  | Min       | Typ | Max | Min              | Max  |      |  |              |             |
| Propagation delay time | t <sub>PLH</sub> | —         | 4.8 | 6.8 | 1.0              | 8.0  | ns   | C <sub>L</sub> = 15 pF<br>C <sub>L</sub> = 50 pF | IN           | Y           |
|                        | t <sub>PHL</sub> | —         | 6.3 | 8.8 | 1.0              | 10.0 |      |  |              |             |

Operating Characteristics

C<sub>L</sub> = 50 pF

| Item                          | Symbol          | V <sub>CC</sub> (V) | Ta = 25°C |      |     | Unit | Test Conditions |
|-------------------------------|-----------------|---------------------|-----------|------|-----|------|-----------------|
|                               |                 |                     | Min       | Typ  | Max |      |                 |
| Power dissipation capacitance | C <sub>PD</sub> | 3.3                 | —         | 8.5  | —   | pF   | f = 10 MHz      |
|                               |                 | 5.0                 | —         | 10.0 | —   |      |                 |





Package Dimensions

Unit: mm

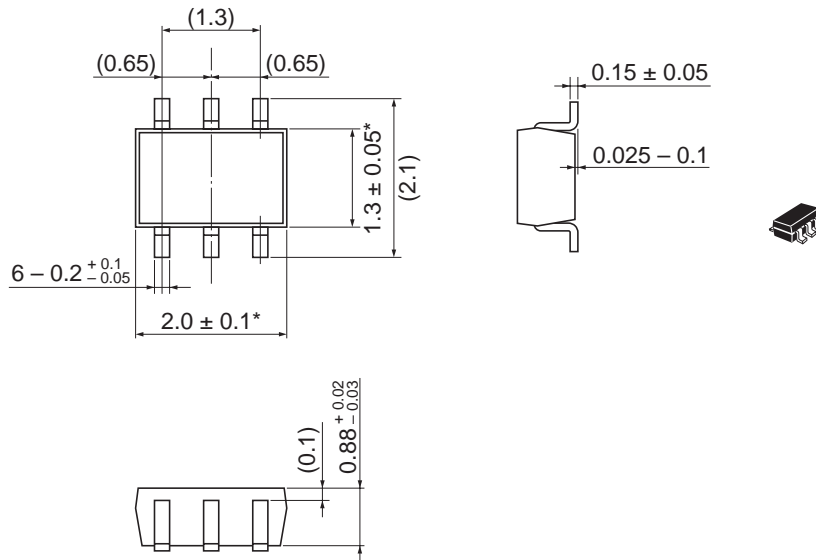

- \* Sn-Bi plating.
- \*\* The value does not include Resin Bar.  
(One side: 0.15 mm (max))

|                        |             |
|------------------------|-------------|
| Package Code           | CMPAK-6V(O) |
| JEDEC                  | —           |
| JEITA                  | Conforms    |
| Mass (reference value) | 0.006 g     |

**Renesas Technology Corp.** Sales Strategic Planning Div. Nippon Bldg., 2-6-2, Ohte-machi, Chiyoda-ku, Tokyo 100-0004, Japan

---

**Keep safety first in your circuit designs!**

1. Renesas Technology Corp. puts the maximum effort into making semiconductor products better and more reliable, but there is always the possibility that trouble may occur with them. Trouble with semiconductors may lead to personal injury, fire or property damage. Remember to give due consideration to safety when making your circuit designs, with appropriate measures such as (i) placement of substitutive, auxiliary circuits, (ii) use of nonflammable material or (iii) prevention against any malfunction or mishap.

**Notes regarding these materials**

1. These materials are intended as a reference to assist our customers in the selection of the Renesas Technology Corp. product best suited to the customer's application; they do not convey any license under any intellectual property rights, or any other rights, belonging to Renesas Technology Corp. or a third party.
  2. Renesas Technology Corp. assumes no responsibility for any damage, or infringement of any third-party's rights, originating in the use of any product data, diagrams, charts, programs, algorithms, or circuit application examples contained in these materials.
  3. All information contained in these materials, including product data, diagrams, charts, programs and algorithms represents information on products at the time of publication of these materials, and are subject to change by Renesas Technology Corp. without notice due to product improvements or other reasons. It is therefore recommended that customers contact Renesas Technology Corp. or an authorized Renesas Technology Corp. product distributor for the latest product information before purchasing a product listed herein.  
The information described here may contain technical inaccuracies or typographical errors.  
Renesas Technology Corp. assumes no responsibility for any damage, liability, or other loss rising from these inaccuracies or errors.  
Please also pay attention to information published by Renesas Technology Corp. by various means, including the Renesas Technology Corp. Semiconductor home page (<http://www.renesas.com>).
  4. When using any or all of the information contained in these materials, including product data, diagrams, charts, programs, and algorithms, please be sure to evaluate all information as a total system before making a final decision on the applicability of the information and products. Renesas Technology Corp. assumes no responsibility for any damage, liability or other loss resulting from the information contained herein.
  5. Renesas Technology Corp. semiconductors are not designed or manufactured for use in a device or system that is used under circumstances in which human life is potentially at stake. Please contact Renesas Technology Corp. or an authorized Renesas Technology Corp. product distributor when considering the use of a product contained herein for any specific purposes, such as apparatus or systems for transportation, vehicular, medical, aerospace, nuclear, or undersea repeater use.
  6. The prior written approval of Renesas Technology Corp. is necessary to reprint or reproduce in whole or in part these materials.
  7. If these products or technologies are subject to the Japanese export control restrictions, they must be exported under a license from the Japanese government and cannot be imported into a country other than the approved destination.  
Any diversion or reexport contrary to the export control laws and regulations of Japan and/or the country of destination is prohibited.
  8. Please contact Renesas Technology Corp. for further details on these materials or the products contained therein.
- 



**RENESAS SALES OFFICES**

<http://www.renesas.com>

**Renesas Technology America, Inc.**

450 Holger Way, San Jose, CA 95134-1368, U.S.A  
Tel: <1> (408) 382-7500 Fax: <1> (408) 382-7501

**Renesas Technology Europe Limited.**

Dukes Meadow, Millboard Road, Bourne End, Buckinghamshire, SL8 5FH, United Kingdom  
Tel: <44> (1628) 585 100, Fax: <44> (1628) 585 900

**Renesas Technology Europe GmbH**

Dornacher Str. 3, D-85622 Feldkirchen, Germany  
Tel: <49> (89) 380 70 0, Fax: <49> (89) 929 30 11

**Renesas Technology Hong Kong Ltd.**

7/F., North Tower, World Finance Centre, Harbour City, Canton Road, Hong Kong  
Tel: <852> 2265-6688, Fax: <852> 2375-6836

**Renesas Technology Taiwan Co., Ltd.**

FL 10, #99, Fu-Hsing N. Rd., Taipei, Taiwan  
Tel: <886> (2) 2715-2888, Fax: <886> (2) 2713-2999

**Renesas Technology (Shanghai) Co., Ltd.**

26/F., Ruijin Building, No.205 Maoming Road (S), Shanghai 200020, China  
Tel: <86> (21) 6472-1001, Fax: <86> (21) 6415-2952

**Renesas Technology Singapore Pte. Ltd.**

1, Harbour Front Avenue, #06-10, Keppel Bay Tower, Singapore 098632  
Tel: <65> 6213-0200, Fax: <65> 6278-8001

