

Single 16 and 8/Differential 8-Channel and 4-Channel CMOS Analog Multiplexers

The HI-506/HI-507 and HI-508/HI-509 monolithic CMOS multiplexers each include an array of sixteen and eight analog switches respectively, a digital decoder circuit for channel selection, voltage reference for logic thresholds, and an enable input for device selection when several multiplexers are present. The Dielectric Isolation (DI) process used in fabrication of these devices eliminates the problem of latchup. DI also offers much lower substrate leakage and parasitic capacitance than conventional junction isolated CMOS (see Application Notes AN520 and AN521).

The switching threshold for each digital input is established by an internal +5V reference, providing a guaranteed minimum 2.4V for logic "1" and maximum 0.8V for logic "0". This allows direct interface without pullup resistors to signals from most logic families: CMOS, TTL, DTL and some PMOS. For protection against transient overvoltage, the digital inputs include a series 200Ω resistor and diode clamp to each supply.

The HI-506 is a single 16-channel, the HI-507 is an 8-channel differential, the HI-508 is a single 8-channel and the HI-509 is a 4-channel differential multiplexer.

If input overvoltages are present, the HI-546/HI-547/HI-548/HI-549 multiplexers are recommended.

Features

- Low ON Resistance 180Ω
- Wide Analog Signal Range ±15V
- TTL/CMOS Compatible
- Access Time 250ns
- Maximum Power Supply 44V
- Break-Before-Make Switching
- No Latch-Up
- Replaces DG506A/DG506AA and DG507A/DG507AA
- Replaces DG508A/DG508AA and DG509A/DG509AA

Applications

- Data Acquisition Systems
- Precision Instrumentation
- Demultiplexing
- Selector Switch

Ordering Information

PART NUMBER	TEMP. RANGE (°C)	PACKAGE	PKG. DWG. #
HI1-0506-2	-55 to 125	28 Ld CERDIP	F28.6
HI1-0506-5	0 to 75	28 Ld CERDIP	F28.6
HI3-0506-5	0 to 75	28 Ld PDIP	E28.6
HI4P0506-5	0 to 75	28 Ld PLCC	N28.45
HI9P0506-9	-40 to 85	28 Ld SOIC	M28.3
HI1-0507-2	-55 to 125	28 Ld CERDIP	F28.6
HI3-0507-5	0 to 75	28 Ld PDIP	E28.6
HI1-0508-2	-55 to 125	16 Ld CERDIP	F16.3
HI1-0508-5	0 to 75	16 Ld CERDIP	F16.3
HI3-0508-5	0 to 75	16 Ld PDIP	E16.3
HI9P0508-5	0 to 75	16 Ld SOIC	M16.15
HI9P0508-9	-40 to 85	16 Ld SOIC	M16.15
HI1-0509-2	-55 to 125	16 Ld CERDIP	F16.3
HI1-0509-4	-25 to 85	16 Ld CERDIP	F16.3
HI1-0509-5	0 to 75	16 Ld CERDIP	F16.3
HI3-0509-5	0 to 75	16 Ld PDIP	E16.3
HI4P0509-5	0 to 75	20 Ld PLCC	N20.35
HI9P0509-5	0 to 75	16 Ld SOIC	M16.15

Pinouts

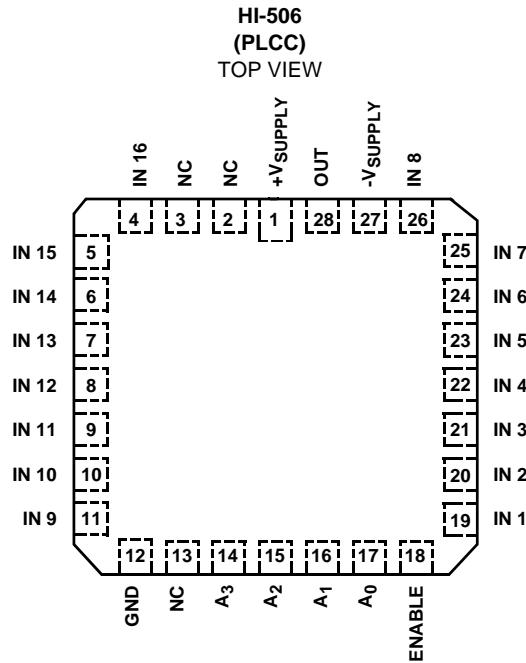
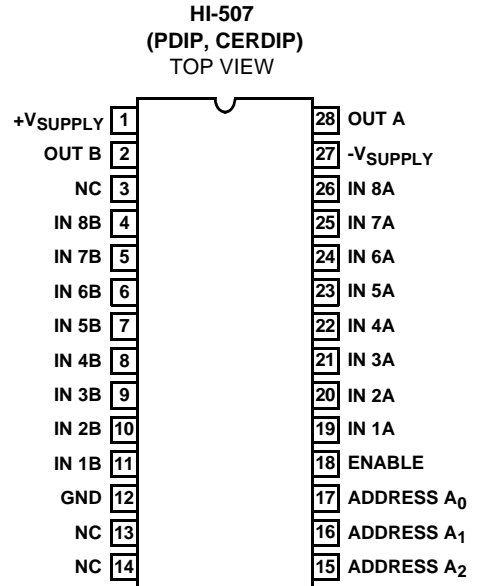
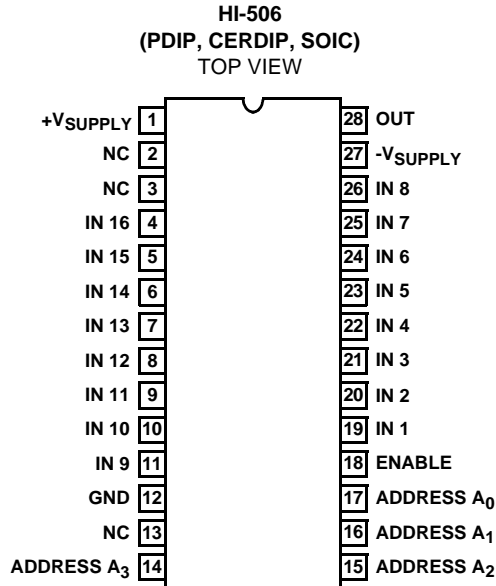

Pinouts (Continued)

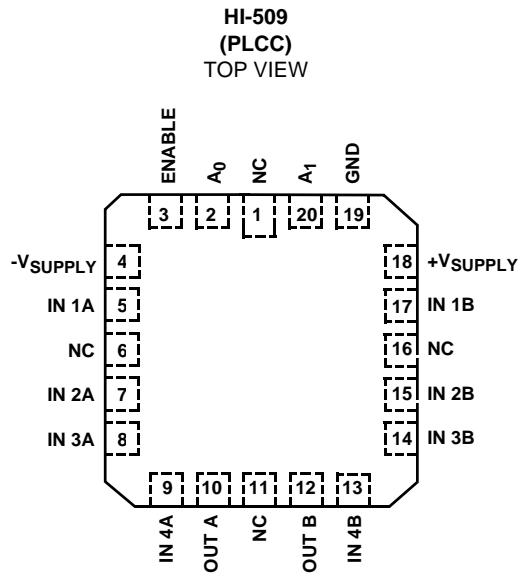
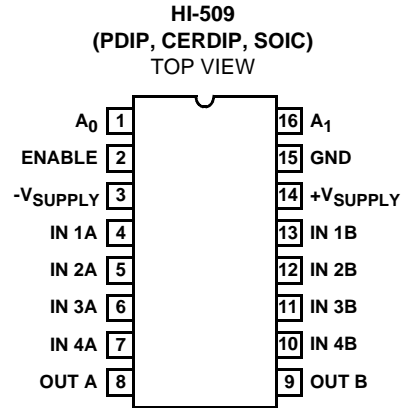
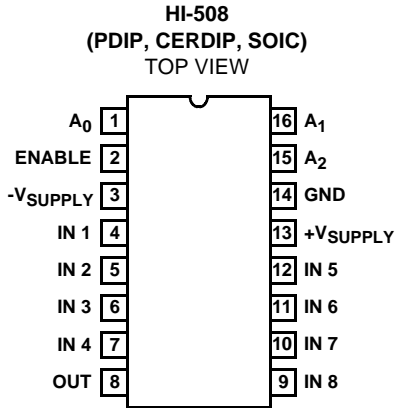

Truth Tables

HI-506

A ₃	A ₂	A ₁	A ₀	EN	"ON" CHANNEL
X	X	X	X	L	None
L	L	L	L	H	1
L	L	L	H	H	2
L	L	H	L	H	3
L	L	H	H	H	4
L	H	L	L	H	5
L	H	L	H	H	6
L	H	H	L	H	7
L	H	H	H	H	8
H	L	L	L	H	9
H	L	L	H	H	10
H	L	H	L	H	11
H	L	H	H	H	12
H	H	L	L	H	13
H	H	L	H	H	14
H	H	H	L	H	15
H	H	H	H	H	16

HI-508

A ₂	A ₁	A ₀	EN	"ON" CHANNEL
X	X	X	L	None
L	L	L	H	1
L	L	H	H	2
L	H	L	H	3
L	H	H	H	4
H	L	L	H	5
H	L	H	H	6
H	H	L	H	7
H	H	H	H	8

HI-509

A ₁	A ₀	EN	"ON" CHANNEL PAIR
X	X	L	None
L	L	H	1
L	H	H	2
H	L	H	3
H	H	H	4

HI-507

A ₂	A ₁	A ₀	EN	"ON" CHANNEL
X	X	X	L	None
L	L	L	H	1
L	L	H	H	2
L	H	L	H	3
L	H	H	H	4
H	L	L	H	5
H	L	H	H	6
H	H	L	H	7
H	H	H	H	8

Functional Diagrams

HI-506

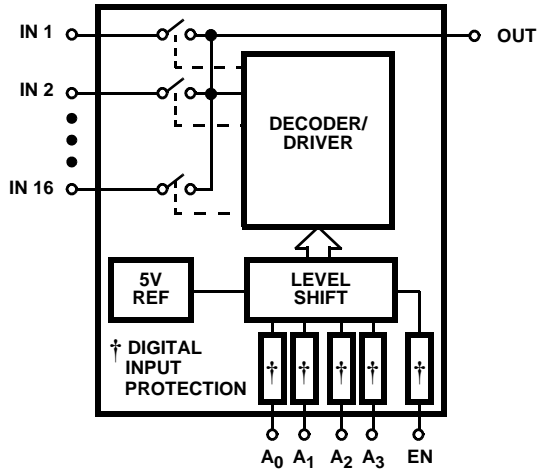

HI-507

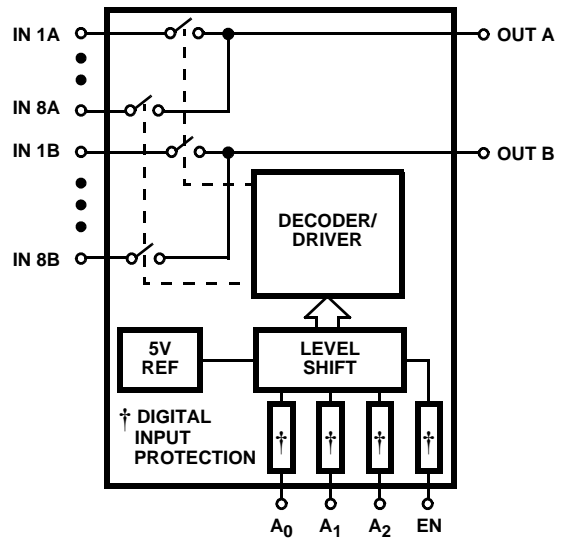

HI-508

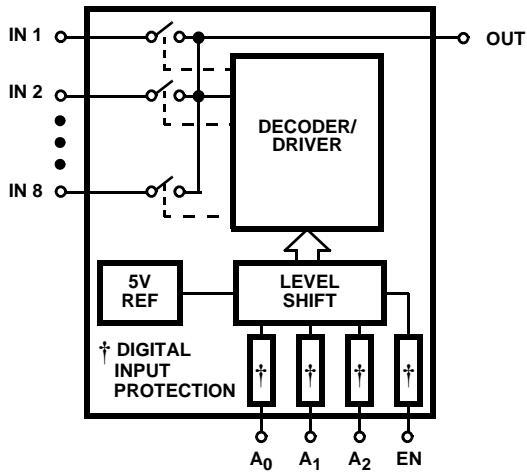

HI-509

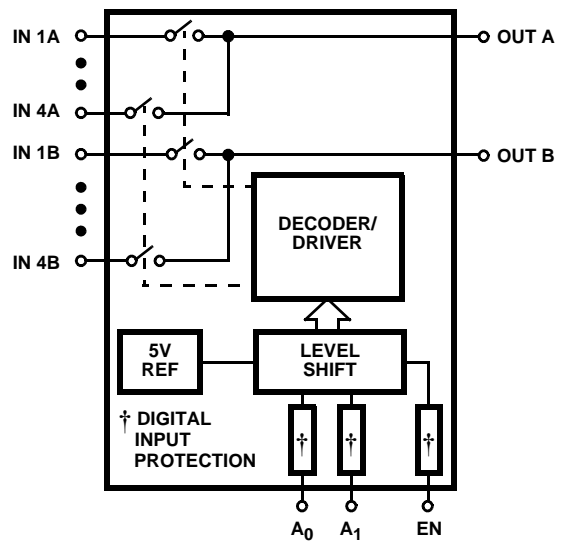

Schematic Diagrams

ADDRESS DECODER

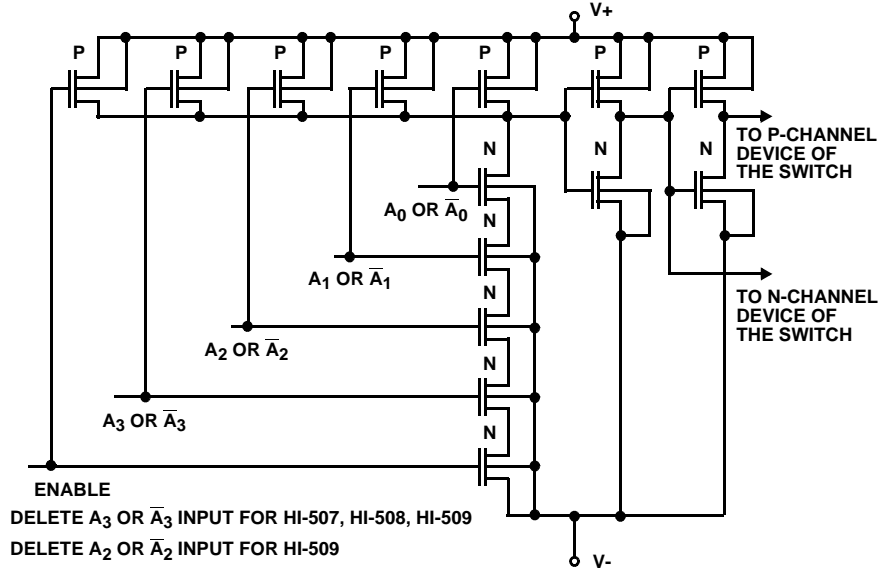

ADDRESS INPUT BUFFER LEVEL SHIFTER

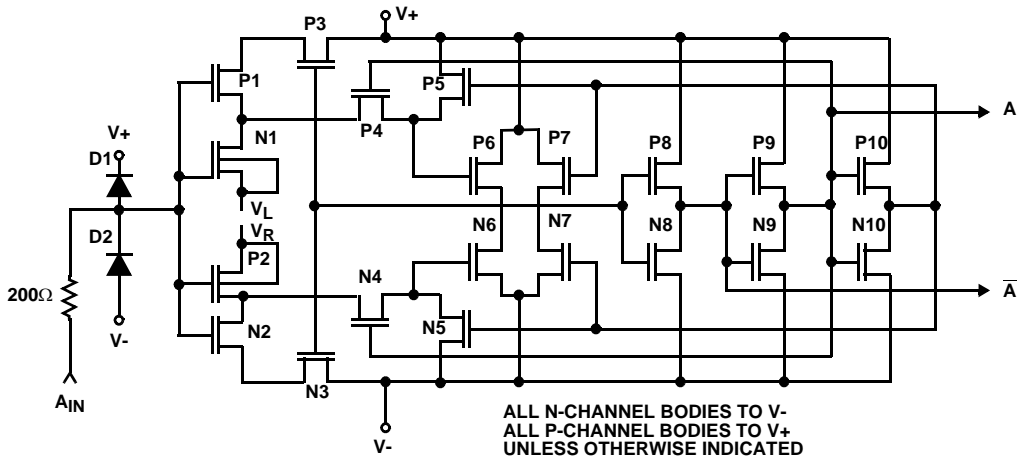

TTL REFERENCE CIRCUIT

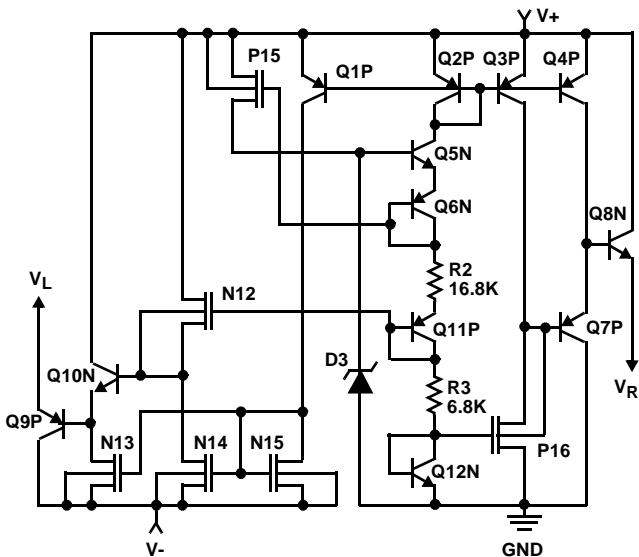

MULTIPLEX SWITCH

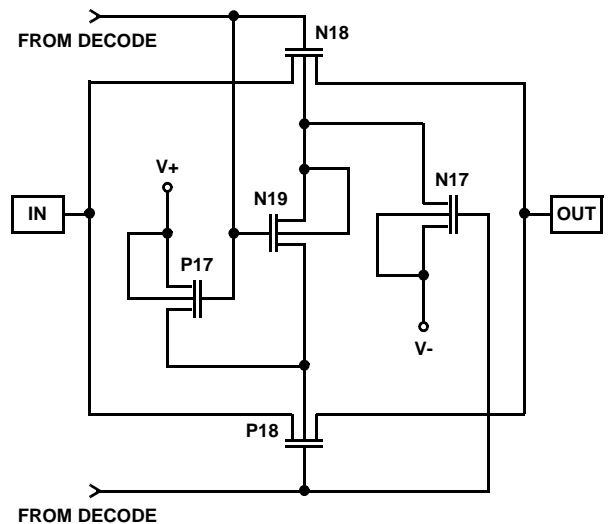

HI-506, HI-507, HI-508, HI-509

Absolute Maximum Ratings

V+ to V-	+44V
V+ to GND	+22V
V- to GND	-25V
Digital Input Voltage (V _{EN} , V _A) (V-) -4V to (V+) +4V or 20mA, Whichever Occurs First	
Analog Signal (V _{IN} , V _{OUT} , Note 2) (V-) -2V to (V+) +2V	
Continuous Current, In or Out	20mA
Peak Current, In or Out (Pulsed 1ms, 10% Duty Cycle Max) .	40mA

Operating Conditions

Temperature Ranges	
HI-506/507/508/509-2	-55°C to 125°C
HI-506/508/509-4	-25°C to 85°C
HI-506/507/508/509-5	0°C to 75°C
HI-506/508-9	-40°C to 85°C
Typical Minimum Supply Voltage.	±10V or Single 20V

Thermal Information

Thermal Resistance (Typical, Note 1)	θ_{JA} (°C/W)	θ_{JC} (°C/W)
16 Ld CERDIP Package.	85	32
16 Ld SOIC Package	115	N/A
16 Ld PDIP Package	100	N/A
20 Ld PLCC Package.	80	N/A
28 Ld CERDIP Package.	55	18
28 Ld PDIP Package	60	N/A
28 Ld SOIC Package	70	N/A
28 Ld PLCC Package.	70	N/A
Maximum Junction Temperature		
Ceramic Packages	175°C	
Plastic Packages	150°C	
Maximum Storage Temperature Range	-65°C to 150°C	
Maximum Lead Temperature (Soldering 10s)	300°C	
	(SOIC and PLCC - Lead Tips Only)	

CAUTION: Stresses above those listed in "Absolute Maximum Ratings" may cause permanent damage to the device. This is a stress only rating and operation of the device at these or any other conditions above those indicated in the operational sections of this specification is not implied.

NOTE:

- θ_{JA} is measured with the component mounted on a low effective thermal conductivity test board in free air. See Tech Brief TB379 for details.
- Signals on IN or OUT exceeding V+ or V- are clamped by internal diodes. Limit resulting current to maximum current ratings. If an overvoltage condition is anticipated (analog input exceeds either power supply voltage), the Intersil HI-546/HI-547/HI-548/HI-549 multiplexers are recommended.

Electrical Specifications

Supplies = +15V, -15V; V_{AH} (Logic Level High) = 2.4V; V_{AL} (Logic Level Low) = 0.8V,
Unless Otherwise Specified. For Test Conditions, Consult Test Circuits Section

PARAMETER	TEST CONDITIONS	TEMP (°C)	-2			-4, -5, -9			UNITS
			MIN	TYP	MAX	MIN	TYP	MAX	
DYNAMIC CHARACTERISTICS									
Access Time, t _A		25	-	250	500	-	250	-	ns
		Full	-	-	1000	-	-	1000	ns
Break-Before-Make Delay, t _{OPEN}		25	25	80	-	25	80	-	ns
Enable Delay (ON), t _{ON(EN)}		25	-	250	500	-	250	-	ns
		Full	-	-	1000	-	-	1000	ns
Enable Delay (OFF), t _{OFF(EN)}		25	-	250	500	-	250	-	ns
		Full	-	-	1000	-	-	1000	ns
Settling Time, t _S (HI-506 and HI-507)	To 0.1%	25	-	1.2	-	-	1.2	-	μs
	To 0.01%	25	-	2.4	-	-	2.4	-	μs
Settling Time, t _S (HI-508 and HI-509)	To 0.1%	25	-	360	-	-	360	-	ns
	To 0.01%	25	-	600	-	-	600	-	ns
Off Isolation	Note 6	25	50	68	-	50	68	-	dB
Channel Input Capacitance, C _{S(OFF)}		25	-	10	-	-	10	-	pF
Channel Output Capacitance, C _{D(OFF)}	HI-506	25	-	52	-	-	52	-	pF
	HI-507	25	-	30	-	-	30	-	pF
	HI-508	25	-	17	-	-	17	-	pF
	HI-509	25	-	12	-	-	12	-	pF
Digital Input Capacitance, C _A		25	-	6	-	-	6	-	pF
Input to Output Capacitance, C _{DS(OFF)}		25	-	0.08	-	-	0.08	-	pF
DIGITAL INPUT CHARACTERISTICS									
Input Low Threshold, V _{AL}		Full	-	-	0.8	-	-	0.8	V
Input High Threshold, V _{AH}		Full	2.4	-	-	2.4	-	-	V
Input Leakage Current (High or Low), I _A	Note 5	Full	-	-	1.0	-	-	1.0	μA

HI-506, HI-507, HI-508, HI-509

Electrical Specifications Supplies = +15V, -15V; V_{AH} (Logic Level High) = 2.4V; V_{AL} (Logic Level Low) = 0.8V, Unless Otherwise Specified. For Test Conditions, Consult Test Circuits Section **(Continued)**

PARAMETER	TEST CONDITIONS	TEMP (°C)	-2			-4, -5, -9			UNITS	
			MIN	TYP	MAX	MIN	TYP	MAX		
ANALOG CHANNEL CHARACTERISTICS										
Analog Signal Range, V_{IN}		Full	-15	-	+15	-15	-	+15	V	
On Resistance, r_{ON}	Note 3	25	-	180	300	-	180	400	Ω	
Δr_{ON} , (Any Two Channels)		25	-	5	-	-	5	-	%	
Off Input Leakage Current, $I_{S(OFF)}$	Note 4	25	-	0.03	-	-	0.03	-	nA	
Off Output Leakage Current, $I_{D(OFF)}$	Note 4	25	-	0.3	-	-	0.3	-	nA	
		HI-506	Full	-	-	300	-	-	300	nA
		HI-507	Full	-	-	200	-	-	200	nA
		HI-508	Full	-	-	200	-	-	200	nA
		HI-509	Full	-	-	100	-	-	100	nA
On Channel Leakage Current, $I_{D(ON)}$	Note 4	25	-	0.3	-	-	0.3	-	nA	
HI-506		Full	-	-	300	-	-	300	nA	
HI-507		Full	-	-	200	-	-	200	nA	
HI-508		Full	-	-	200	-	-	200	nA	
HI-509		Full	-	-	100	-	-	100	nA	
Differential Off Output Leakage Current, I_{DIFF} (HI-507, HI-509 Only)		Full	-	-	50	-	-	50	nA	
POWER SUPPLY CHARACTERISTICS										
Current, I_+	Note 7	Full	-	1.5	3.0	-	1.5	3.0	mA	
HI-506/HI-507										
HI-508/HI-509	Note 7	Full	-	1.5	2.4	-	1.5	2.4	mA	
Current, I_-	Note 7	Full	-	0.4	1.0	-	0.4	1.0	mA	
HI-506/HI-507										
HI-508/HI-509	Note 7	Full	-	0.4	1.0	-	0.4	1.0	mA	
Power Dissipation, P_D		Full	-	-	60	-	-	60	mW	
HI-506/HI-507										
HI-508/HI-509		Full	-	-	51	-	-	51	mW	

NOTES:

3. $V_{OUT} = \pm 10V$, $I_{OUT} = \pm 1mA$.
4. 10nA is the practical lower limit for high speed measurement in the production test environment.
5. Digital input leakage is primarily due to the clamp diodes (see Schematic). Typical leakage is less than 1nA at 25°C.
6. $V_{EN} = 0.8V$, $R_L = 1K$, $C_L = 15pF$, $V_S = 7V_{RMS}$, $f = 100kHz$.
7. V_{EN} , $V_A = 0V$ or 2.4V.

Test Circuits and Waveforms $T_A = 25^\circ C$, $V_{SUPPLY} = \pm 15V$, $V_{AH} = 2.4V$, $V_{AL} = 0.8V$, Unless Otherwise Specified

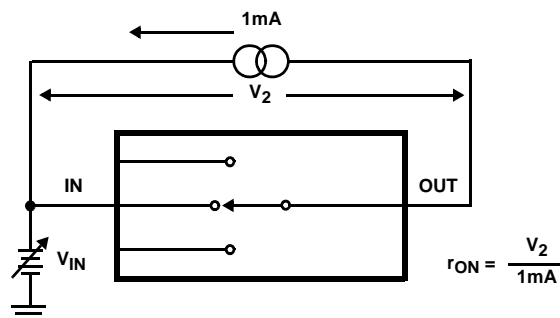

FIGURE 1A. TEST CIRCUIT

Test Circuits and Waveforms $T_A = 25^\circ\text{C}$, $V_{\text{SUPPLY}} = \pm 15\text{V}$, $V_{\text{AH}} = 2.4\text{V}$, $V_{\text{AL}} = 0.8\text{V}$, Unless Otherwise Specified (Continued)

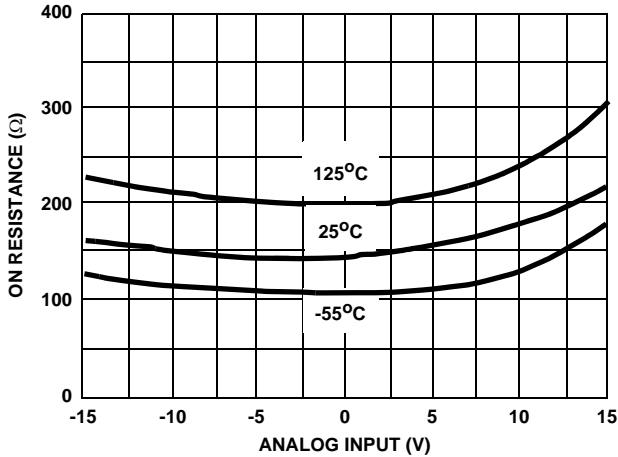

FIGURE 1B. ON RESISTANCE vs ANALOG INPUT VOLTAGE

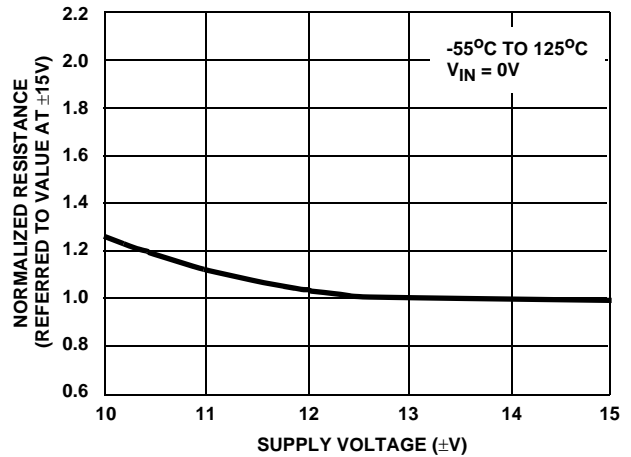

FIGURE 1C. NORMALIZED ON RESISTANCE vs SUPPLY VOLTAGE

FIGURE 1. ON RESISTANCE

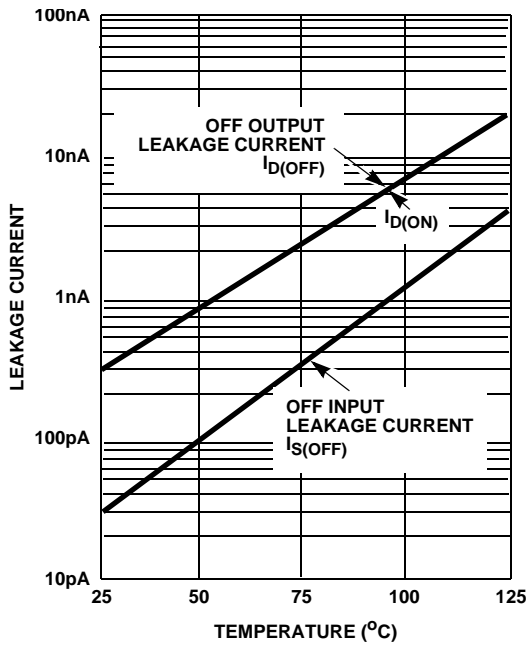

FIGURE 2A. LEAKAGE CURRENT vs TEMPERATURE

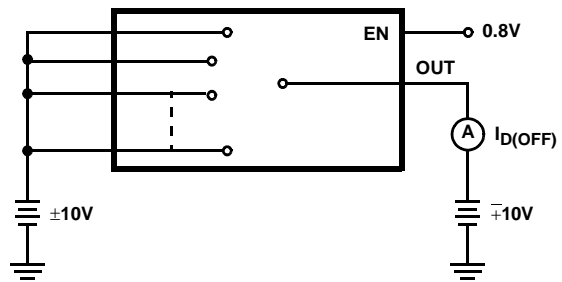

FIGURE 2B. $I_{\text{D(OFF)}}$ TEST CIRCUIT (NOTE 8)

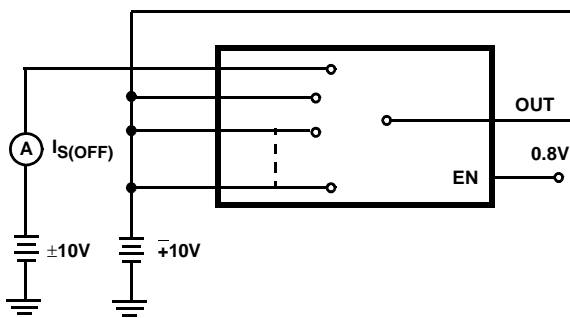

FIGURE 2C. $I_{\text{S(OFF)}}$ TEST CIRCUIT (NOTE 8)

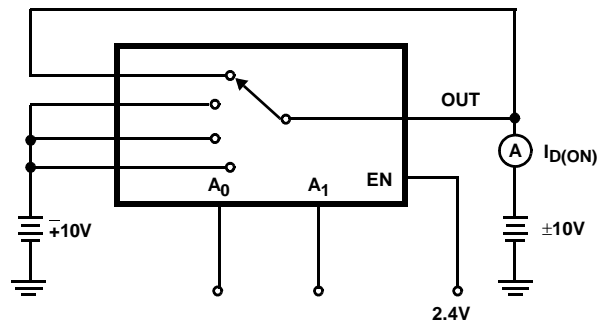

FIGURE 2D. $I_{\text{D(ON)}}$ TEST CIRCUIT (NOTE 8)

FIGURE 2. LEAKAGE CURRENTS

NOTE:

8. Two measurements per channel: $\pm 10\text{V}$ and $\mp 10\text{V}$. (Two measurements per device for $I_{\text{D(OFF)}}$ $\pm 10\text{V}$ and $\mp 10\text{V}$)

Test Circuits and Waveforms $T_A = 25^\circ\text{C}$, $V_{\text{SUPPLY}} = \pm 15\text{V}$, $V_{\text{AH}} = 2.4\text{V}$, $V_{\text{AL}} = 0.8\text{V}$, Unless Otherwise Specified (Continued)

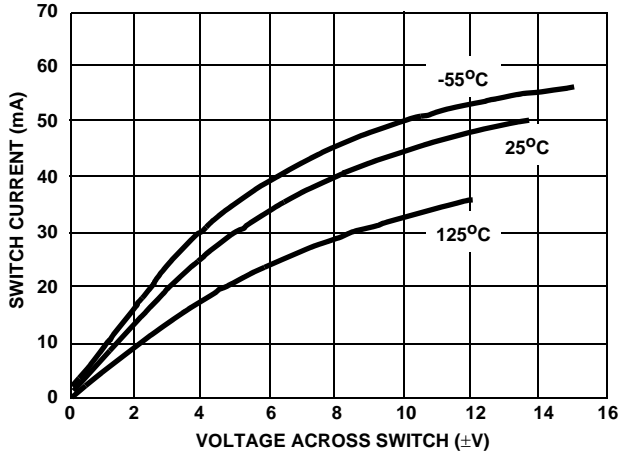

FIGURE 3A. ON CHANNEL CURRENT vs VOLTAGE

FIGURE 3. ON CHANNEL CURRENT

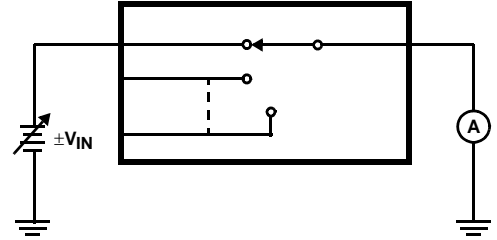

FIGURE 3B. TEST CIRCUIT

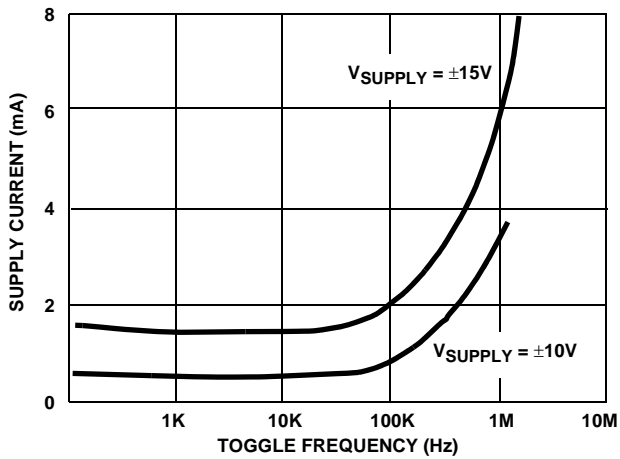

FIGURE 4A. SUPPLY CURRENT vs TOGGLE FREQUENCY

FIGURE 4. DYNAMIC SUPPLY CURRENT

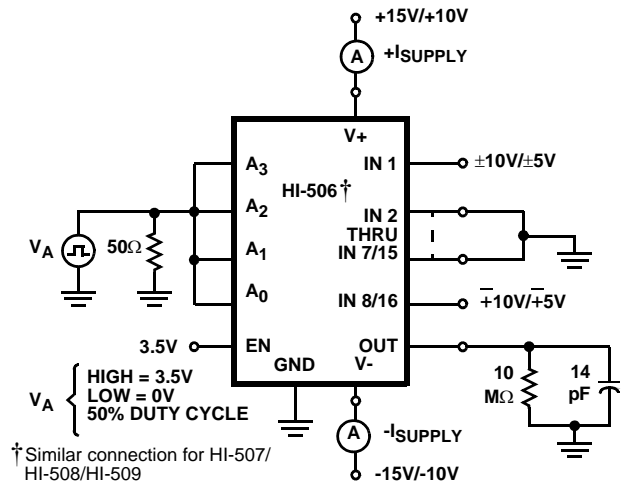

FIGURE 4B. TEST CIRCUIT

Test Circuits and Waveforms $T_A = 25^\circ\text{C}$, $V_{\text{SUPPLY}} = \pm 15\text{V}$, $V_{\text{AH}} = 2.4\text{V}$, $V_{\text{AL}} = 0.8\text{V}$, Unless Otherwise Specified (Continued)

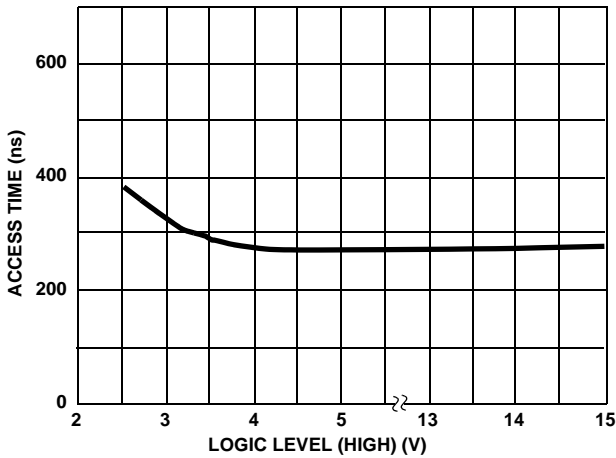

FIGURE 5A. ACCESS TIME vs LOGIC LEVEL (HIGH)

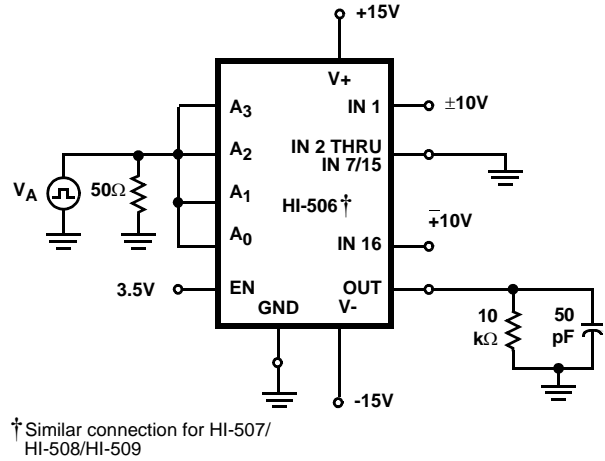

FIGURE 5B. TEST CIRCUIT

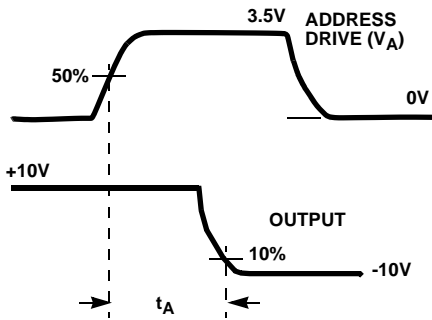

FIGURE 5C. MEASUREMENT POINTS

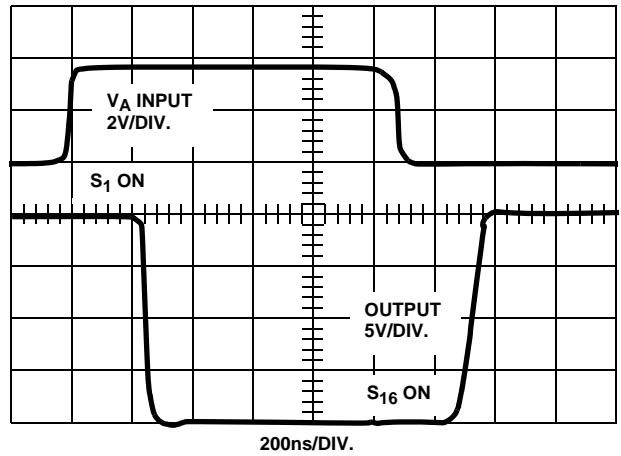

FIGURE 5D. WAVEFORMS

FIGURE 5. ACCESS TIME

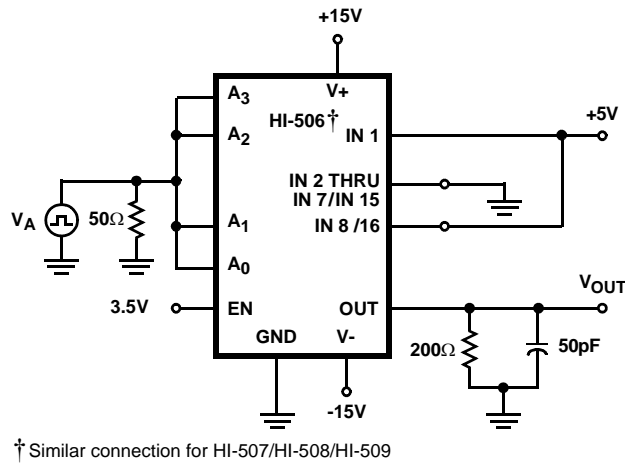

FIGURE 6A. TEST CIRCUIT

Test Circuits and Waveforms $T_A = 25^\circ\text{C}$, $V_{\text{SUPPLY}} = \pm 15\text{V}$, $V_{\text{AH}} = 2.4\text{V}$, $V_{\text{AL}} = 0.8\text{V}$, Unless Otherwise Specified (Continued)

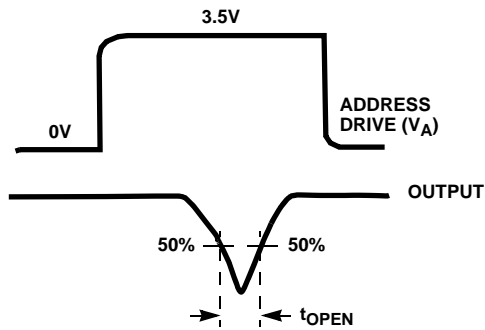

FIGURE 6B. MEASUREMENT POINTS

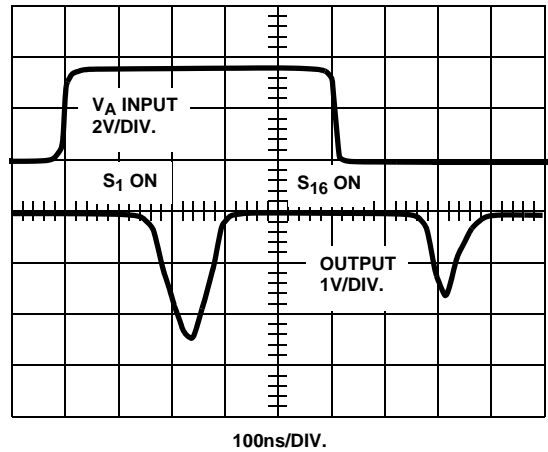

FIGURE 6C. WAVEFORMS

FIGURE 6. BREAK-BEFORE-MAKE DELAY

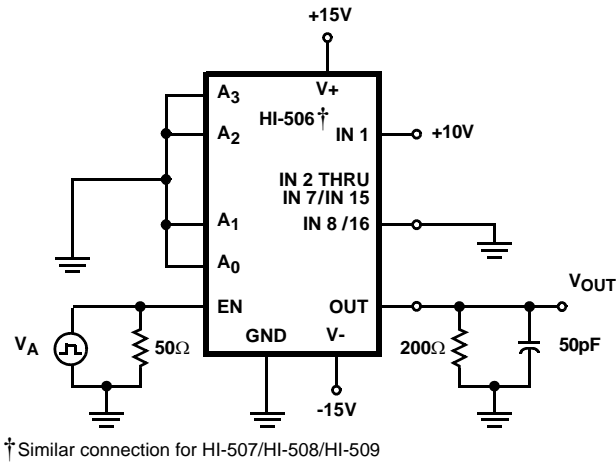

FIGURE 7A. TEST CIRCUIT

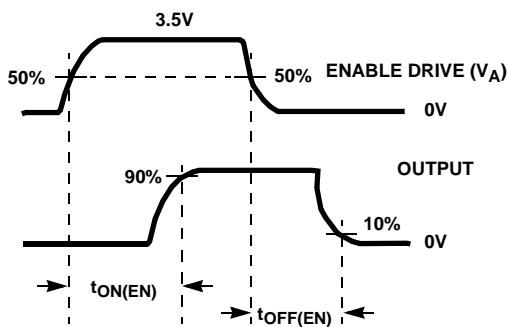

FIGURE 7B. MEASUREMENT POINTS

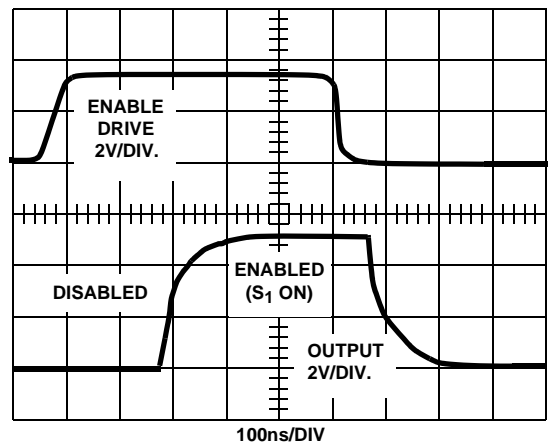

FIGURE 7C. WAVEFORMS

FIGURE 7. ENABLE DELAYS

Typical Performance Curves $T_A = 25^\circ\text{C}$, $V_{\text{SUPPLY}} = \pm 15\text{V}$, $V_{\text{AH}} = 2.4\text{V}$, $V_{\text{AL}} = 0.8\text{V}$, Unless Otherwise Specified

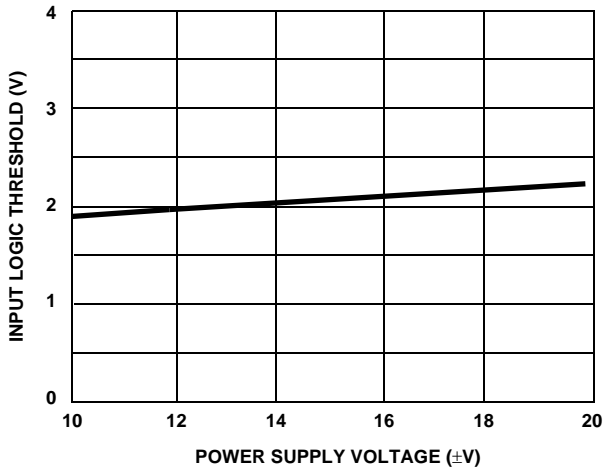

FIGURE 8. LOGIC THRESHOLD vs POWER SUPPLY VOLTAGE

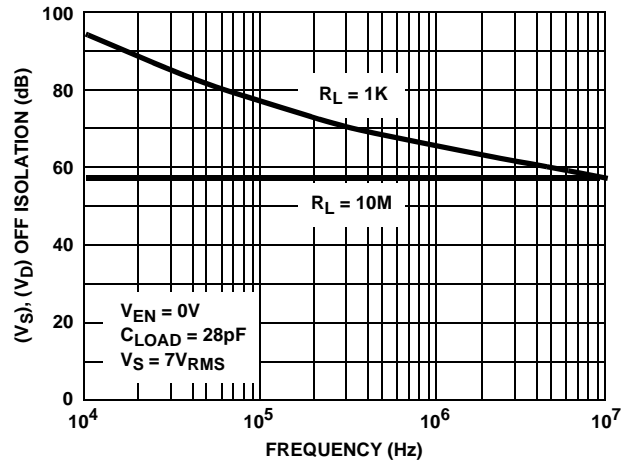

FIGURE 9. OFF ISOLATION vs FREQUENCY

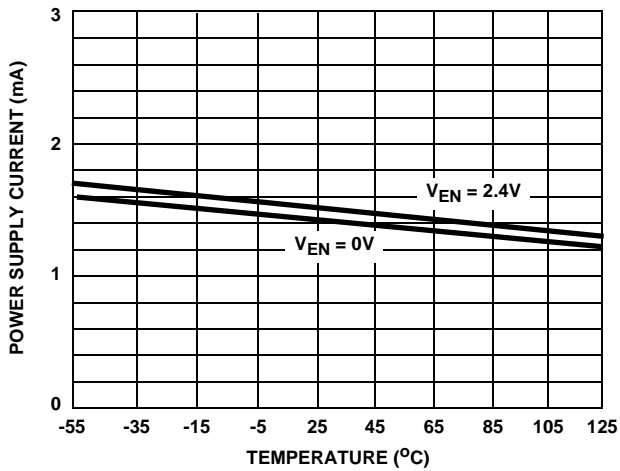

FIGURE 10A. HI-506/HI-507

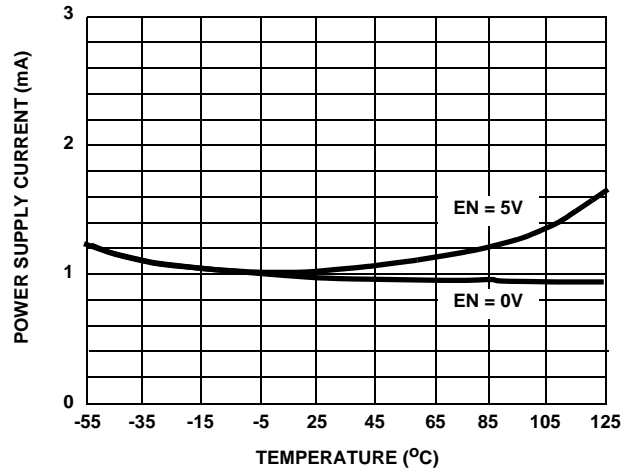

FIGURE 10B. HI-508/HI-509

FIGURE 10. POWER SUPPLY CURRENT vs TEMPERATURE

Die Characteristics

DIE DIMENSIONS:

129 mils x 82 mils

METALLIZATION:

Type: CuAl

Thickness: $16k\text{\AA} \pm 2k\text{\AA}$

SUBSTRATE POTENTIAL (NOTE):

$-V_{\text{SUPPLY}}$

PASSIVATION:

Type: Nitride/Silox

Nitride Thickness: $3.5k\text{\AA} \pm 1k\text{\AA}$

Silox Thickness: $12k\text{\AA} \pm 2k\text{\AA}$

WORST CASE CURRENT DENSITY:

$1.4 \times 10^5 \text{ A/cm}^2$

TRANSISTOR COUNT:

421

PROCESS:

CMOS-DI

NOTE: The substrate appears resistive to the $-V_{\text{SUPPLY}}$ terminal, therefore it may be left floating (Insulating Die Mount) or it may be mounted on a conductor at $-V_{\text{SUPPLY}}$ potential.

Metallization Mask Layout

HI-506

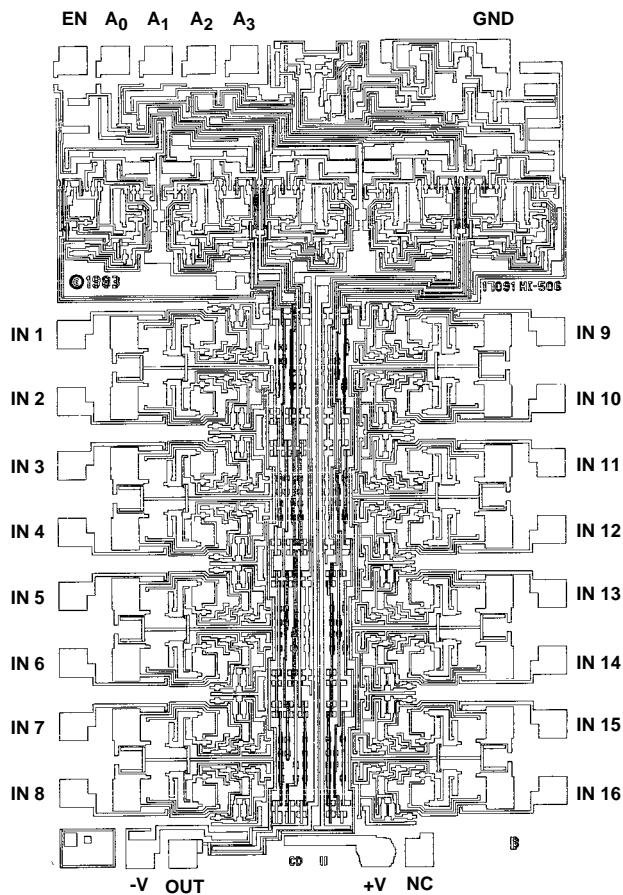

HI-507

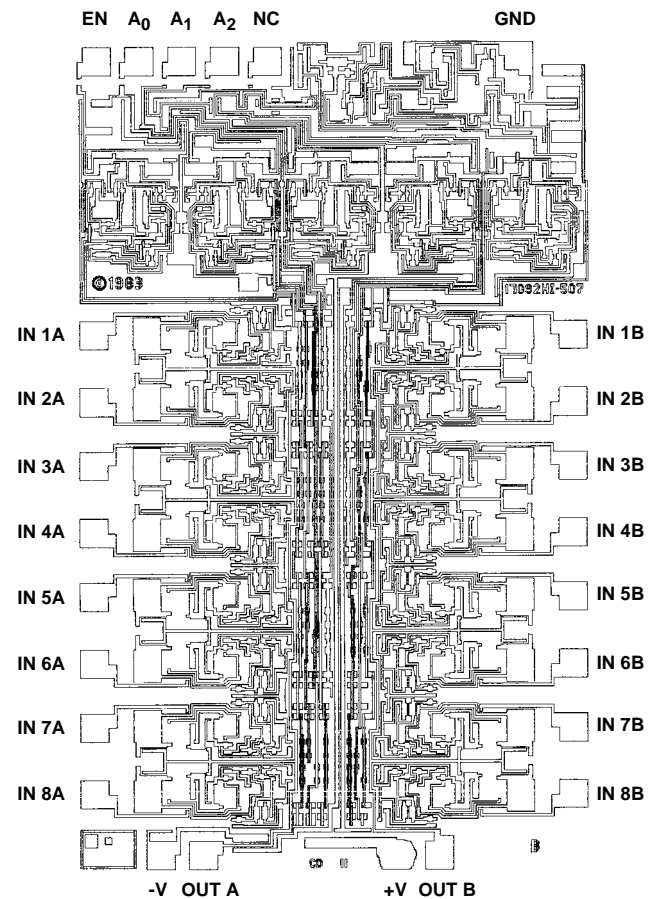

Die Characteristics

DIE DIMENSIONS:

81.9 mils x 90.2 mils

METALLIZATION:

Type: CuAl

Thickness: $16\text{k}\text{\AA} \pm 2\text{k}\text{\AA}$

SUBSTRATE POTENTIAL (NOTE):

$-V_{\text{SUPPLY}}$

PASSIVATION:

Type: Nitride/Silox

Nitride Thickness: $3.5\text{k}\text{\AA} \pm 1\text{k}\text{\AA}$

Silox Thickness: $12\text{k}\text{\AA} \pm 2\text{k}\text{\AA}$

WORST CASE CURRENT DENSITY:

$1.4 \times 10^5 \text{ A/cm}^2$

TRANSISTOR COUNT:

234

PROCESS:

CMOS-DI

NOTE: The substrate appears resistive to the $-V_{\text{SUPPLY}}$ terminal, therefore it may be left floating (Insulating Die Mount) or it may be mounted on a conductor at $-V_{\text{SUPPLY}}$ potential.

Metallization Mask Layout

HI-508

HI-509

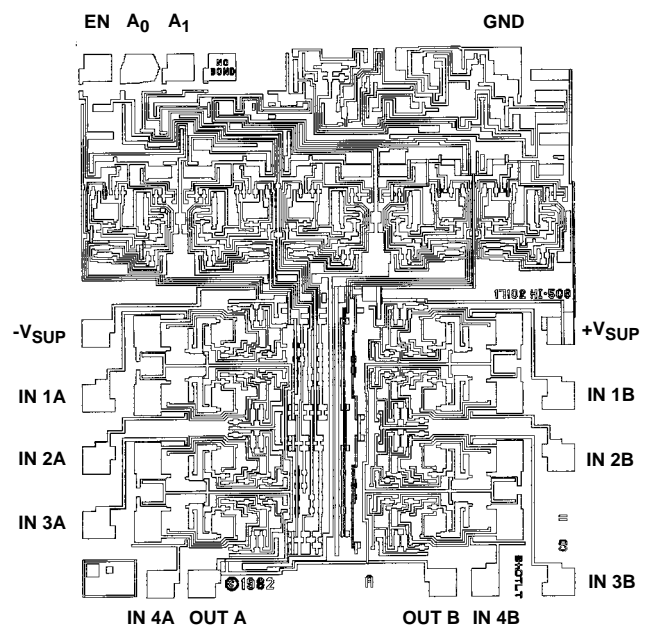
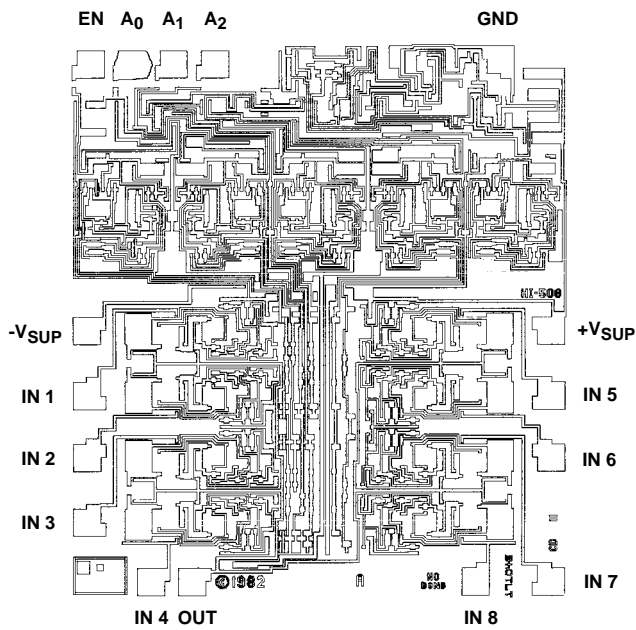

Dual-In-Line Plastic Packages (PDIP)

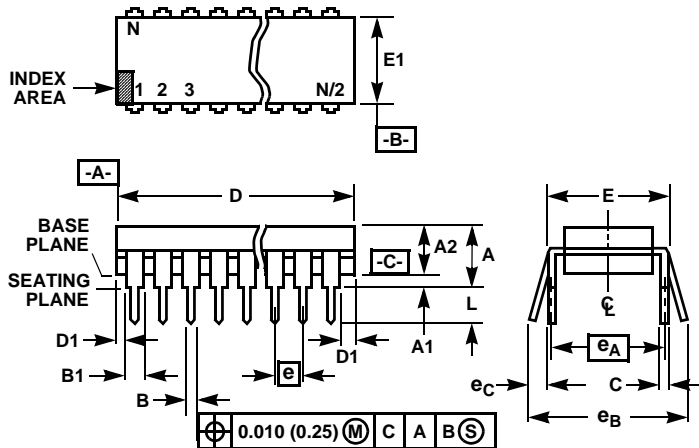

NOTES:

- Controlling Dimensions: INCH. In case of conflict between English and Metric dimensions, the inch dimensions control.
- Dimensioning and tolerancing per ANSI Y14.5M-1982.
- Symbols are defined in the "MO Series Symbol List" in Section 2.2 of Publication No. 95.
- Dimensions A, A1 and L are measured with the package seated in JEDEC seating plane gauge GS-3.
- D, D1, and E1 dimensions do not include mold flash or protrusions. Mold flash or protrusions shall not exceed 0.010 inch (0.25mm).
- E and e_A are measured with the leads constrained to be perpendicular to datum $-C-$.
- e_B and e_C are measured at the lead tips with the leads unconstrained. e_C must be zero or greater.
- B1 maximum dimensions do not include dambar protrusions. Dambar protrusions shall not exceed 0.010 inch (0.25mm).
- N is the maximum number of terminal positions.
- Corner leads (1, N, N/2 and N/2 + 1) for E8.3, E16.3, E18.3, E28.3, E42.6 will have a B1 dimension of 0.030 - 0.045 inch (0.76 - 1.14mm).

E16.3 (JEDEC MS-001-BB ISSUE D)
16 LEAD DUAL-IN-LINE PLASTIC PACKAGE

SYMBOL	INCHES		MILLIMETERS		NOTES
	MIN	MAX	MIN	MAX	
A	-	0.210	-	5.33	4
A1	0.015	-	0.39	-	4
A2	0.115	0.195	2.93	4.95	-
B	0.014	0.022	0.356	0.558	-
B1	0.045	0.070	1.15	1.77	8, 10
C	0.008	0.014	0.204	0.355	-
D	0.735	0.775	18.66	19.68	5
D1	0.005	-	0.13	-	5
E	0.300	0.325	7.62	8.25	6
E1	0.240	0.280	6.10	7.11	5
e	0.100 BSC		2.54 BSC		-
e_A	0.300 BSC		7.62 BSC		6
e_B	-	0.430	-	10.92	7
L	0.115	0.150	2.93	3.81	4
N	16		16		9

Rev. 0 12/93

Dual-In-Line Plastic Packages (PDIP)

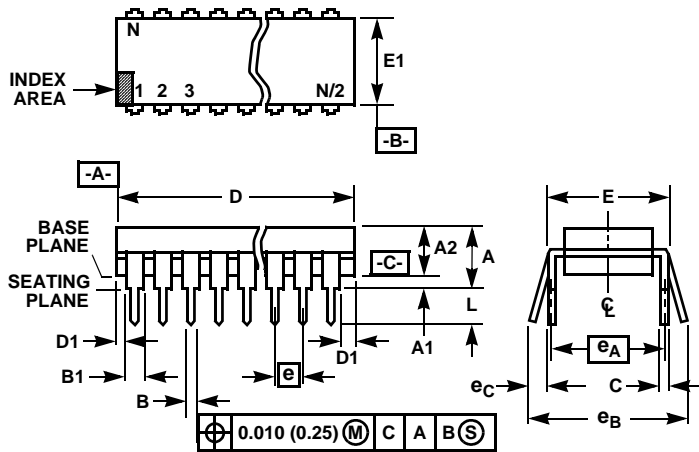

NOTES:

1. Controlling Dimensions: INCH. In case of conflict between English and Metric dimensions, the inch dimensions control.
2. Dimensioning and tolerancing per ANSI Y14.5M-1982.
3. Symbols are defined in the "MO Series Symbol List" in Section 2.2 of Publication No. 95.
4. Dimensions A, A1 and L are measured with the package seated in JEDEC seating plane gauge GS-3.
5. D, D1, and E1 dimensions do not include mold flash or protrusions. Mold flash or protrusions shall not exceed 0.010 inch (0.25mm).
6. E and e_A are measured with the leads constrained to be perpendicular to datum $-C-$.
7. e_B and e_C are measured at the lead tips with the leads unconstrained. e_C must be zero or greater.
8. B1 maximum dimensions do not include dambar protrusions. Dambar protrusions shall not exceed 0.010 inch (0.25mm).
9. N is the maximum number of terminal positions.
10. Corner leads (1, N, N/2 and N/2 + 1) for E8.3, E16.3, E18.3, E28.3, E42.6 will have a B1 dimension of 0.030 - 0.045 inch (0.76 - 1.14mm).

E28.6 (JEDEC MS-011-AB ISSUE B)
28 LEAD DUAL-IN-LINE PLASTIC PACKAGE

SYMBOL	INCHES		MILLIMETERS		NOTES
	MIN	MAX	MIN	MAX	
A	-	0.250	-	6.35	4
A1	0.015	-	0.39	-	4
A2	0.125	0.195	3.18	4.95	-
B	0.014	0.022	0.356	0.558	-
B1	0.030	0.070	0.77	1.77	8
C	0.008	0.015	0.204	0.381	-
D	1.380	1.565	35.1	39.7	5
D1	0.005	-	0.13	-	5
E	0.600	0.625	15.24	15.87	6
E1	0.485	0.580	12.32	14.73	5
e	0.100 BSC		2.54 BSC		-
e_A	0.600 BSC		15.24 BSC		6
e_B	-	0.700	-	17.78	7
L	0.115	0.200	2.93	5.08	4
N	28		28		9

Rev. 1 12/00

Ceramic Dual-In-Line Frit Seal Packages (CERDIP)

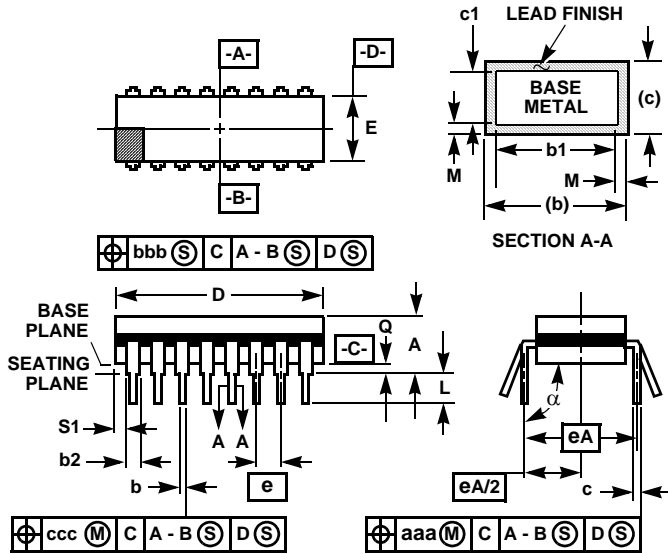

NOTES:

1. Index area: A notch or a pin one identification mark shall be located adjacent to pin one and shall be located within the shaded area shown. The manufacturer's identification shall not be used as a pin one identification mark.
2. The maximum limits of lead dimensions b and c or M shall be measured at the centroid of the finished lead surfaces, when solder dip or tin plate lead finish is applied.
3. Dimensions b1 and c1 apply to lead base metal only. Dimension M applies to lead plating and finish thickness.
4. Corner leads (1, N, N/2, and N/2+1) may be configured with a partial lead paddle. For this configuration dimension b3 replaces dimension b2.
5. This dimension allows for off-center lid, meniscus, and glass overrun.
6. Dimension Q shall be measured from the seating plane to the base plane.
7. Measure dimension S1 at all four corners.
8. N is the maximum number of terminal positions.
9. Dimensioning and tolerancing per ANSI Y14.5M - 1982.
10. Controlling dimension: INCH.

F16.3 MIL-STD-1835 GDIP1-T16 (D-2, CONFIGURATION A)
16 LEAD CERAMIC DUAL-IN-LINE FRIT SEAL PACKAGE

SYMBOL	INCHES		MILLIMETERS		NOTES
	MIN	MAX	MIN	MAX	
A	-	0.200	-	5.08	-
b	0.014	0.026	0.36	0.66	2
b1	0.014	0.023	0.36	0.58	3
b2	0.045	0.065	1.14	1.65	-
b3	0.023	0.045	0.58	1.14	4
c	0.008	0.018	0.20	0.46	2
c1	0.008	0.015	0.20	0.38	3
D	-	0.840	-	21.34	5
E	0.220	0.310	5.59	7.87	5
e	0.100 BSC		2.54 BSC		-
eA	0.300 BSC		7.62 BSC		-
eA/2	0.150 BSC		3.81 BSC		-
L	0.125	0.200	3.18	5.08	-
Q	0.015	0.060	0.38	1.52	6
S1	0.005	-	0.13	-	7
alpha	90°	105°	90°	105°	-
aaa	-	0.015	-	0.38	-
bbb	-	0.030	-	0.76	-
ccc	-	0.010	-	0.25	-
M	-	0.0015	-	0.038	2, 3
N	16		16		8

Rev. 0 4/94

Ceramic Dual-In-Line Frit Seal Packages (CERDIP)

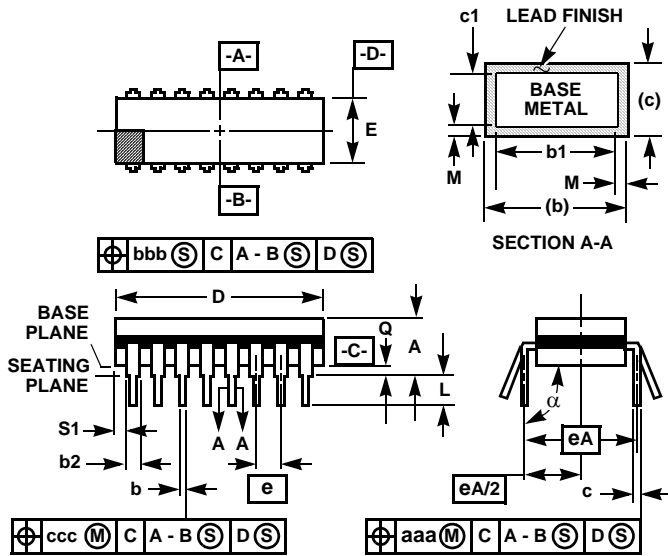

NOTES:

1. Index area: A notch or a pin one identification mark shall be located adjacent to pin one and shall be located within the shaded area shown. The manufacturer's identification shall not be used as a pin one identification mark.
2. The maximum limits of lead dimensions b and c or M shall be measured at the centroid of the finished lead surfaces, when solder dip or tin plate lead finish is applied.
3. Dimensions b1 and c1 apply to lead base metal only. Dimension M applies to lead plating and finish thickness.
4. Corner leads (1, N, N/2, and N/2+1) may be configured with a partial lead paddle. For this configuration dimension b3 replaces dimension b2.
5. This dimension allows for off-center lid, meniscus, and glass overrun.
6. Dimension Q shall be measured from the seating plane to the base plane.
7. Measure dimension S1 at all four corners.
8. N is the maximum number of terminal positions.
9. Dimensioning and tolerancing per ANSI Y14.5M - 1982.
10. Controlling dimension: INCH.

**F28.6 MIL-STD-1835 GDIP1-T28 (D-10, CONFIGURATION A)
28 LEAD CERAMIC DUAL-IN-LINE FRIT SEAL PACKAGE**

SYMBOL	INCHES		MILLIMETERS		NOTES
	MIN	MAX	MIN	MAX	
A	-	0.232	-	5.92	-
b	0.014	0.026	0.36	0.66	2
b1	0.014	0.023	0.36	0.58	3
b2	0.045	0.065	1.14	1.65	-
b3	0.023	0.045	0.58	1.14	4
c	0.008	0.018	0.20	0.46	2
c1	0.008	0.015	0.20	0.38	3
D	-	1.490	-	37.85	5
E	0.500	0.610	12.70	15.49	5
e	0.100 BSC		2.54 BSC		-
eA	0.600 BSC		15.24 BSC		-
eA/2	0.300 BSC		7.62 BSC		-
L	0.125	0.200	3.18	5.08	-
Q	0.015	0.060	0.38	1.52	6
S1	0.005	-	0.13	-	7
alpha	90°	105°	90°	105°	-
aaa	-	0.015	-	0.38	-
bbb	-	0.030	-	0.76	-
ccc	-	0.010	-	0.25	-
M	-	0.0015	-	0.038	2, 3
N	28		28		8

Rev. 0 4/94

Small Outline Plastic Packages (SOIC)

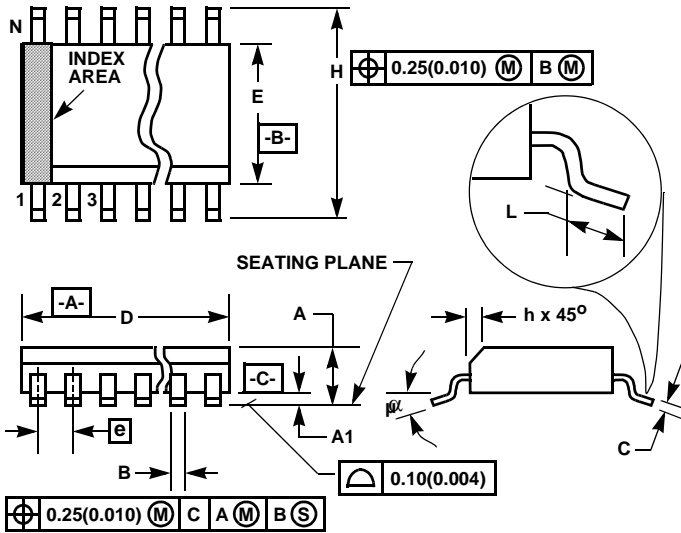

M16.15 (JEDEC MS-012-AC ISSUE C)
16 LEAD NARROW BODY SMALL OUTLINE PLASTIC PACKAGE

SYMBOL	INCHES		MILLIMETERS		NOTES
	MIN	MAX	MIN	MAX	
A	0.0532	0.0688	1.35	1.75	-
A1	0.0040	0.0098	0.10	0.25	-
B	0.013	0.020	0.33	0.51	9
C	0.0075	0.0098	0.19	0.25	-
D	0.3859	0.3937	9.80	10.00	3
E	0.1497	0.1574	3.80	4.00	4
e	0.050 BSC		1.27 BSC		-
H	0.2284	0.2440	5.80	6.20	-
h	0.0099	0.0196	0.25	0.50	5
L	0.016	0.050	0.40	1.27	6
N	16		16		7
α	0°	8°	0°	8°	-

NOTES:

1. Symbols are defined in the "MO Series Symbol List" in Section 2.2 of Publication Number 95.
2. Dimensioning and tolerancing per ANSI Y14.5M-1982.
3. Dimension "D" does not include mold flash, protrusions or gate burrs. Mold flash, protrusion and gate burrs shall not exceed 0.15mm (0.006 inch) per side.
4. Dimension "E" does not include interlead flash or protrusions. Interlead flash and protrusions shall not exceed 0.25mm (0.010 inch) per side.
5. The chamfer on the body is optional. If it is not present, a visual index feature must be located within the crosshatched area.
6. "L" is the length of terminal for soldering to a substrate.
7. "N" is the number of terminal positions.
8. Terminal numbers are shown for reference only.
9. The lead width "B", as measured 0.36mm (0.014 inch) or greater above the seating plane, shall not exceed a maximum value of 0.61mm (0.024 inch).
10. Controlling dimension: MILLIMETER. Converted inch dimensions are not necessarily exact.

Rev. 0 12/93

Small Outline Plastic Packages (SOIC)

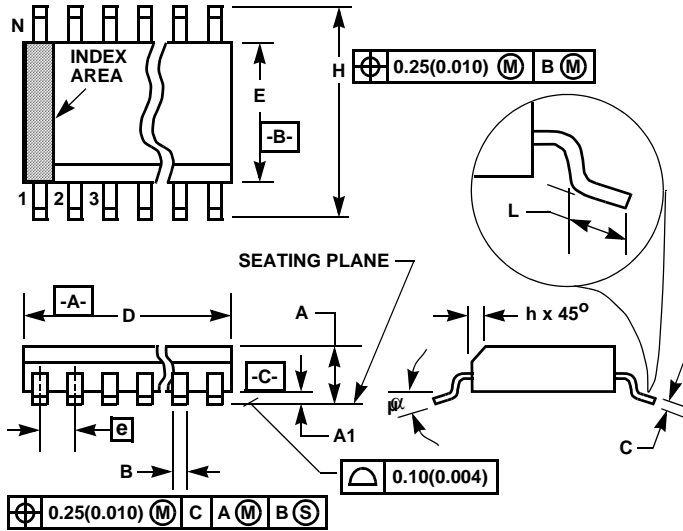

M28.3 (JEDEC MS-013-AE ISSUE C)
28 LEAD WIDE BODY SMALL OUTLINE PLASTIC PACKAGE

SYMBOL	INCHES		MILLIMETERS		NOTES
	MIN	MAX	MIN	MAX	
A	0.0926	0.1043	2.35	2.65	-
A1	0.0040	0.0118	0.10	0.30	-
B	0.013	0.0200	0.33	0.51	9
C	0.0091	0.0125	0.23	0.32	-
D	0.6969	0.7125	17.70	18.10	3
E	0.2914	0.2992	7.40	7.60	4
e	0.05 BSC		1.27 BSC		-
H	0.394	0.419	10.00	10.65	-
h	0.01	0.029	0.25	0.75	5
L	0.016	0.050	0.40	1.27	6
N	28		28		7
α	0°	8°	0°	8°	-

NOTES:

1. Symbols are defined in the "MO Series Symbol List" in Section 2.2 of Publication Number 95.
2. Dimensioning and tolerancing per ANSI Y14.5M-1982.
3. Dimension "D" does not include mold flash, protrusions or gate burrs. Mold flash, protrusion and gate burrs shall not exceed 0.15mm (0.006 inch) per side.
4. Dimension "E" does not include interlead flash or protrusions. Interlead flash and protrusions shall not exceed 0.25mm (0.010 inch) per side.
5. The chamfer on the body is optional. If it is not present, a visual index feature must be located within the crosshatched area.
6. "L" is the length of terminal for soldering to a substrate.
7. "N" is the number of terminal positions.
8. Terminal numbers are shown for reference only.
9. The lead width "B", as measured 0.36mm (0.014 inch) or greater above the seating plane, shall not exceed a maximum value of 0.61mm (0.024 inch)
10. Controlling dimension: MILLIMETER. Converted inch dimensions are not necessarily exact.

Rev. 0 12/93

Plastic Leaded Chip Carrier Packages (PLCC)

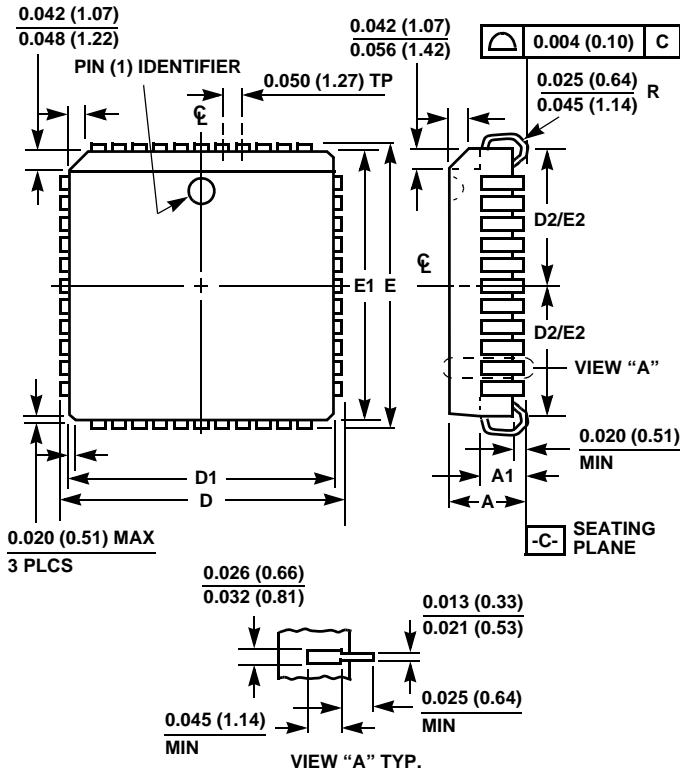

N20.35 (JEDEC MS-018AA ISSUE A)
20 LEAD PLASTIC LEADED CHIP CARRIER PACKAGE

SYMBOL	INCHES		MILLIMETERS		NOTES
	MIN	MAX	MIN	MAX	
A	0.165	0.180	4.20	4.57	-
A1	0.090	0.120	2.29	3.04	-
D	0.385	0.395	9.78	10.03	-
D1	0.350	0.356	8.89	9.04	3
D2	0.141	0.169	3.59	4.29	4, 5
E	0.385	0.395	9.78	10.03	-
E1	0.350	0.356	8.89	9.04	3
E2	0.141	0.169	3.59	4.29	4, 5
N	20		20		6

Rev. 2 11/97

NOTES:

1. Controlling dimension: INCH. Converted millimeter dimensions are not necessarily exact.
2. Dimensions and tolerancing per ANSI Y14.5M-1982.
3. Dimensions D1 and E1 do not include mold protrusions. Allowable mold protrusion is 0.010 inch (0.25mm) per side. Dimensions D1 and E1 include mold mismatch and are measured at the extreme material condition at the body parting line.
4. To be measured at seating plane -C- contact point.
5. Centerline to be determined where center leads exit plastic body.
6. "N" is the number of terminal positions.

Plastic Leaded Chip Carrier Packages (PLCC)

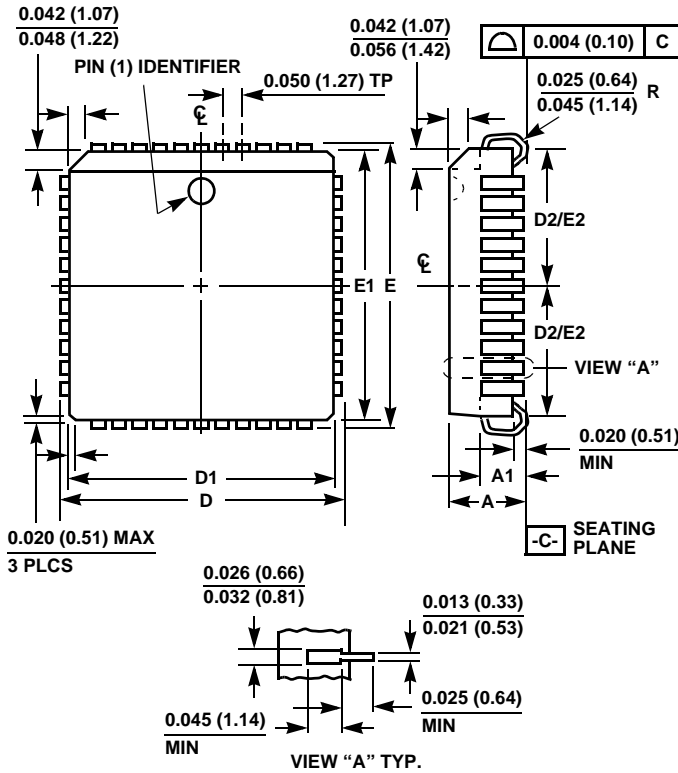

N28.45 (JEDEC MS-018AB ISSUE A)
28 LEAD PLASTIC LEADED CHIP CARRIER PACKAGE

SYMBOL	INCHES		MILLIMETERS		NOTES
	MIN	MAX	MIN	MAX	
A	0.165	0.180	4.20	4.57	-
A1	0.090	0.120	2.29	3.04	-
D	0.485	0.495	12.32	12.57	-
D1	0.450	0.456	11.43	11.58	3
D2	0.191	0.219	4.86	5.56	4, 5
E	0.485	0.495	12.32	12.57	-
E1	0.450	0.456	11.43	11.58	3
E2	0.191	0.219	4.86	5.56	4, 5
N	28		28		6

Rev. 2 11/97

NOTES:

- Controlling dimension: INCH. Converted millimeter dimensions are not necessarily exact.
- Dimensions and tolerancing per ANSI Y14.5M-1982.
- Dimensions D1 and E1 do not include mold protrusions. Allowable mold protrusion is 0.010 inch (0.25mm) per side. Dimensions D1 and E1 include mold mismatch and are measured at the extreme material condition at the body parting line.
- To be measured at seating plane -C- contact point.
- Centerline to be determined where center leads exit plastic body.
- "N" is the number of terminal positions.

All Intersil U.S. products are manufactured, assembled and tested utilizing ISO9000 quality systems.
Intersil Corporation's quality certifications can be viewed at www.intersil.com/design/quality

Intersil products are sold by description only. Intersil Corporation reserves the right to make changes in circuit design, software and/or specifications at any time without notice. Accordingly, the reader is cautioned to verify that data sheets are current before placing orders. Information furnished by Intersil is believed to be accurate and reliable. However, no responsibility is assumed by Intersil or its subsidiaries for its use; nor for any infringements of patents or other rights of third parties which may result from its use. No license is granted by implication or otherwise under any patent or patent rights of Intersil or its subsidiaries.

For information regarding Intersil Corporation and its products, see www.intersil.com