

Features

- Specified from 50 MHz to 20 GHz
- Usable up to 26 GHz
- Low Insertion Loss
- High Isolation
- Low Parasitic Capacitance and Inductance
- RoHS Compliant Surmount™ Package
- Rugged, Fully Monolithic
- Glass Encapsulated Construction
- Up to +38 dBm C.W. Power Handling¹ @ +25°C
- Silicon Nitride Passivation
- Polymer Scratch Protection

Description

The MASW-004103-1365 is a Surmount™ broadband monolithic SP4T switch using series and shunt connected silicon PIN diodes. This part is designed for use as a moderate signal, high performance switch in applications up to 20 GHz. This Surface Mount chipscale configuration is optimized for broadband performance with minimal associated parasitics usually associated with hybrid MIC designs incorporating beam lead and PIN diodes that require chip and wire assembly.

The MASW-004103-1365 is fabricated using M/A-COM Technology Solutions patented HMIC™ (Heterolithic Microwave Integrated Circuit) process, US Patent 5,268,310. This process allows the incorporation of silicon pedestals that form series and shunt diodes or vias by imbedding them in low loss, low dispersion glass. By using small spacing between elements, this combination of silicon and glass gives HMIC devices low loss and high isolation performance through low millimeter frequencies.

Selective backside metalization is applied producing a Surface Mount device. The topside is fully encapsulated with silicon nitride and has an additional polymer layer for scratch and impact protection. These protective coatings prevent damage to the junction and the anode airbridge during handling and assembly.

1. Power Handling Testing performed @ 2GHz

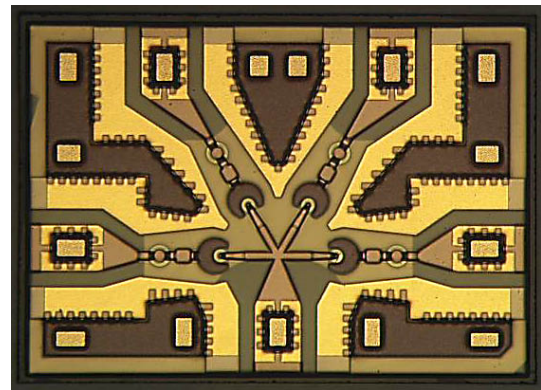

Functional Schematic

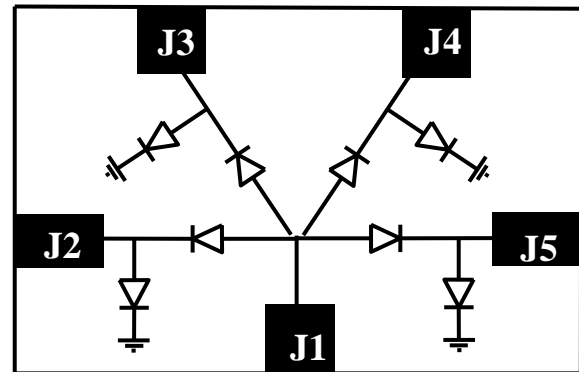

Pin Configuration ²

Pin	Function
J1	RFC
J2	RF1
J3	RF2
J4	RF3
J5	RF4

2. The exposed pad centered on the chip bottom must be connected to RF and DC ground.

Ordering Information

Part Number	Package
MASW-004103-13650G	50 piece gel pack
MASW-004103-13655P	500 piece reel
MASW-004103-13650P	3000 piece reel
MASW-004103-001SMB	Sample Test Board

ADVANCED: Data Sheets contain information regarding a product M/A-COM Technology Solutions is considering for development. Performance is based on target specifications, simulated results, and/or prototype measurements. Commitment to develop is not guaranteed.
PRELIMINARY: Data Sheets contain information regarding a product M/A-COM Technology Solutions has under development. Performance is based on engineering tests. Specifications are typical. Mechanical outline has been fixed. Engineering samples and/or test data may be available. Commitment to produce in volume is not guaranteed.

• **North America** Tel: 800.366.2266 • **Europe** Tel: +353.21.244.6400
• **India** Tel: +91.80.43537383 • **China** Tel: +86.21.2407.1588
Visit www.macomtech.com for additional data sheets and product information.

M/A-COM Technology Solutions Inc. and its affiliates reserve the right to make changes to the product(s) or information contained herein without notice.

HMIC™ Silicon PIN Diode SP4T Switch 50 MHz - 20 GHz

Rev. V4

Electrical Specifications: $T_A = 25^\circ\text{C}$, $P_{IN} = 0 \text{ dBm}$, $Z_0 = 50 \Omega$, 20mA/-10V

Parameter	Conditions	Units	Min.	Typ.	Max.
Insertion Loss	6 GHz	dB	—	0.5	0.6
	13 GHz		—	0.8	1.0
	20 GHz		—	1.2	1.5
Isolation	6 GHz	dB	48	51	—
	13 GHz		38	39	—
	20 GHz		29	32	—
Input Return Loss	6 GHz	dB	17	21	—
	13 GHz		13	17	—
	20 GHz		12	16	—
Output to Output Isolation	6 GHz	dB	—	53.5	—
	13 GHz		—	41.5	—
	20 GHz		—	31.5	—
Input 0.1dB Compression Point	2 GHz	dB	—	36	—
IIP3	0.5 GHz, 5 MHz Spacing, +20dBm	dBm	—	60	—
	1 GHz, 10 MHz Spacing, +20dBm		—	63	—
	2 GHz, 10 MHz Spacing, +20dBm		—	64	—
Switching Speed ³		ns	—	20	—
Voltage Rating ⁴		V	—	—	80

3. Typical Switching Speed measured from 10% to 90 % of detected RF signal driven by TTL compatible drivers.

4. Maximum reverse leakage current in either the shunt or series PIN diodes shall be 0.5 uA maximum @ -80 volts.

Absolute Maximum Ratings^{5,6}

Parameter	Absolute Maximum
Operating Temperature	-65 °C to +125 °C
Storage Temperature	-65 °C to +150 °C
Junction Temperature	+175 °C
Applied Reverse Voltage	-80 V
RF CW Incident Power	38dBm CW @ 2GHz, +25°C 33dBm CW @ 20GHz, +25°C
Bias Current +25°C	± 50 mA

Max Operating Conditions for combination RF Pwr, DC Bias, & Temp: 33dBm CW @ 20mA per Diode @ +85°C @ 2GHz

- Exceeding any one or combination of these limits may cause permanent damage to this device.
- M/A-COM Tech does not recommend sustained operation near these survivability limits.

Handling Procedures

Please observe the following precautions to avoid damage:

Static Sensitivity

These devices are rated at Class 1A Human Body. Proper ESD control techniques should be used when handling these devices.

Typical Performance Curves

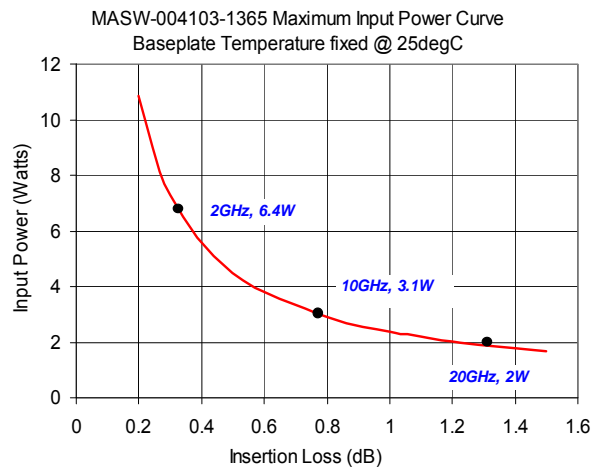
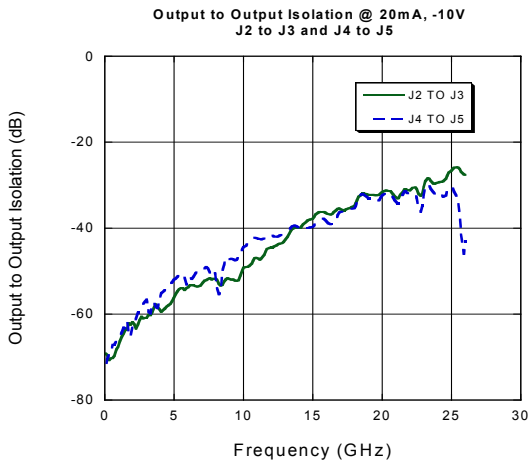
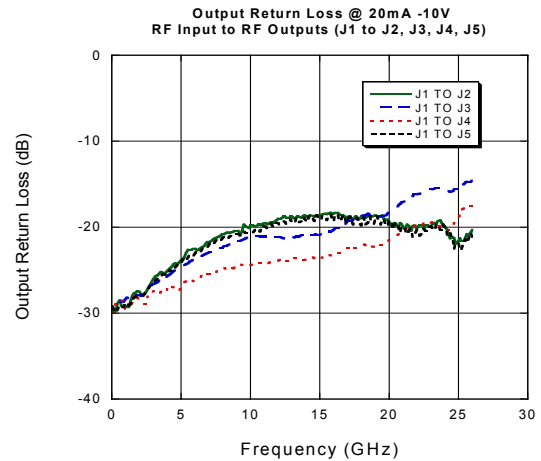
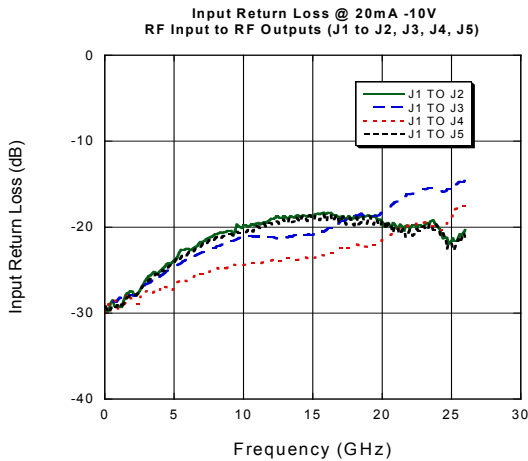
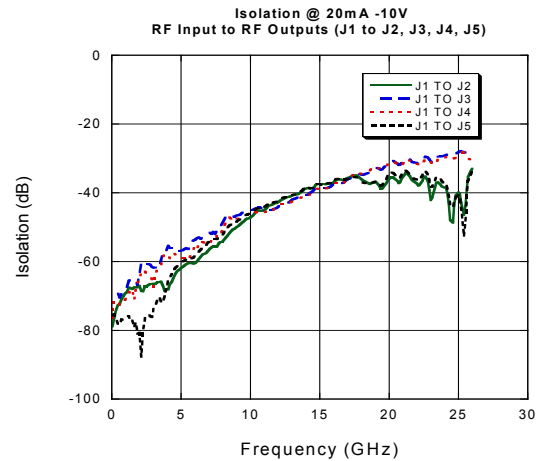
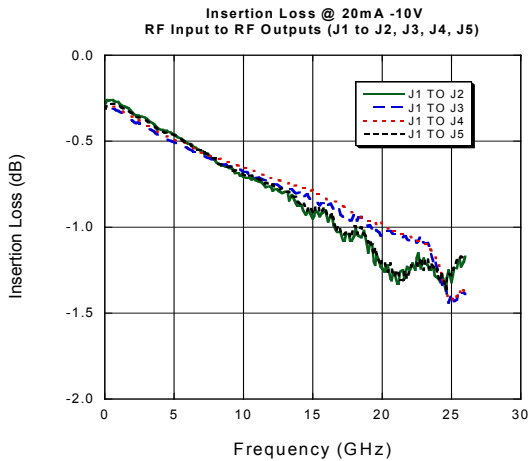

HMIC™ Silicon PIN Diode SP4T Switch 50 MHz - 20 GHz

Rev. V4

Bias Control

Optimal operation of the MASW-004103-1365 is achieved by simultaneous application of negative DC voltage and current to the low loss switching arm and positive DC voltage and current to the remaining switching arms as shown in the applications circuit below. DC return is achieved via R2 on the RFC path. In the low loss state, the series diode must be forward biased with current and the shunt diode reverse biased with voltage. In the isolated arm, the shunt diode is forward biased with current and the series diode is reverse biased with voltage.

Driver Connections

Control Level (DC Currents and Voltages)				Condition of RF Output	Condition of RF Output	Condition of RF Output	Condition of RF Output
B2	B3	B4	B5	J1-J2	J1-J3	J1-J4	J1-J5
-15V at -20mA ⁷	6V at +20mA	6V at +20mA	6V at +20mA	Low Loss	Isolation	Isolation	Isolation
6V at +20mA	-15V at -20mA ⁷	6V at +20mA	6V at +20mA	Isolation	Low Loss	Isolation	Isolation
6V at +20mA	6V at +20mA	-15V at -20mA ⁷	6V at +20mA	Isolation	Isolation	Low Loss	Isolation
6V at +20mA	6V at +20mA	6V at +20mA	-15V at -20mA ⁷	Isolation	Isolation	Isolation	Low Loss

7. The voltage applied to the off arm can vary as long as 20mA is applied through the shunt diode on the off arm.

Application Circuit ^{8,9,10,11,12}

Example:

J1 to J2 → Low Loss
 R1 = 250Ω
 R2 = 450Ω
 B2 = -15V
 B3, B4, B5 = 6V

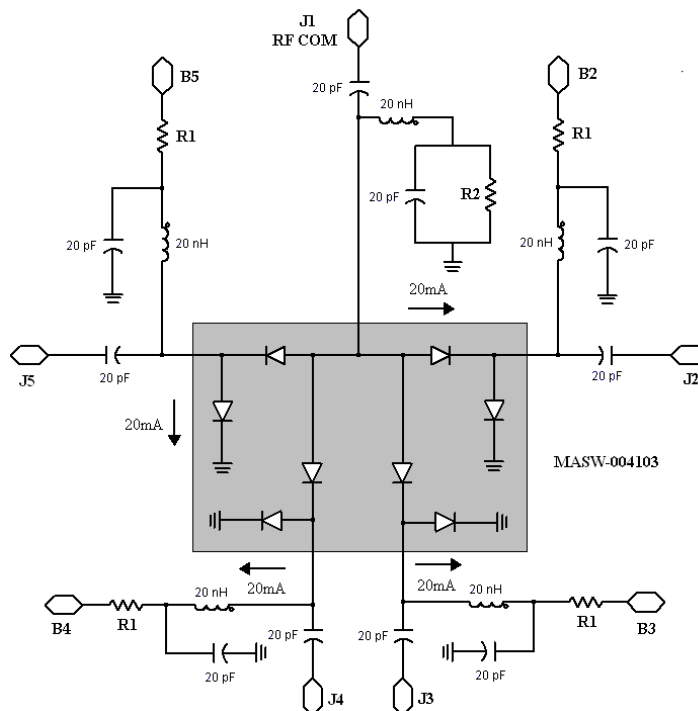

Notes:

- Assume $V_f \sim 1V$ at 20mA
- $R1 = 5V / 0.02A = 250\Omega$; $R2 = 9V / 0.02A = 450\Omega$
- $P_{R1} = 0.02A \times 0.02A \times 250 = 0.1 W$
- $P_{R2} = 0.02A \times 0.02A \times 450 = 0.18 W$
- Inductors are bias RF chokes. The operating band width of a broad-band PIN diode switch is often dependent on the bias components, particularly the RF bias chokes. It is suggested that the frequency response be checked with all the bias components attached before installing the PIN diode.

4

ADVANCED: Data Sheets contain information regarding a product M/A-COM Technology Solutions is considering for development. Performance is based on target specifications, simulated results, and/or prototype measurements. Commitment to develop is not guaranteed.
PRELIMINARY: Data Sheets contain information regarding a product M/A-COM Technology Solutions has under development. Performance is based on engineering tests. Specifications are typical. Mechanical outline has been fixed. Engineering samples and/or test data may be available. Commitment to produce in volume is not guaranteed.

• North America Tel: 800.366.2266 • Europe Tel: +353.21.244.6400
 • India Tel: +91.80.43537383 • China Tel: +86.21.2407.1588
 Visit www.macomtech.com for additional data sheets and product information.

M/A-COM Technology Solutions Inc. and its affiliates reserve the right to make changes to the product(s) or information contained herein without notice.

Outline Drawing Footprint

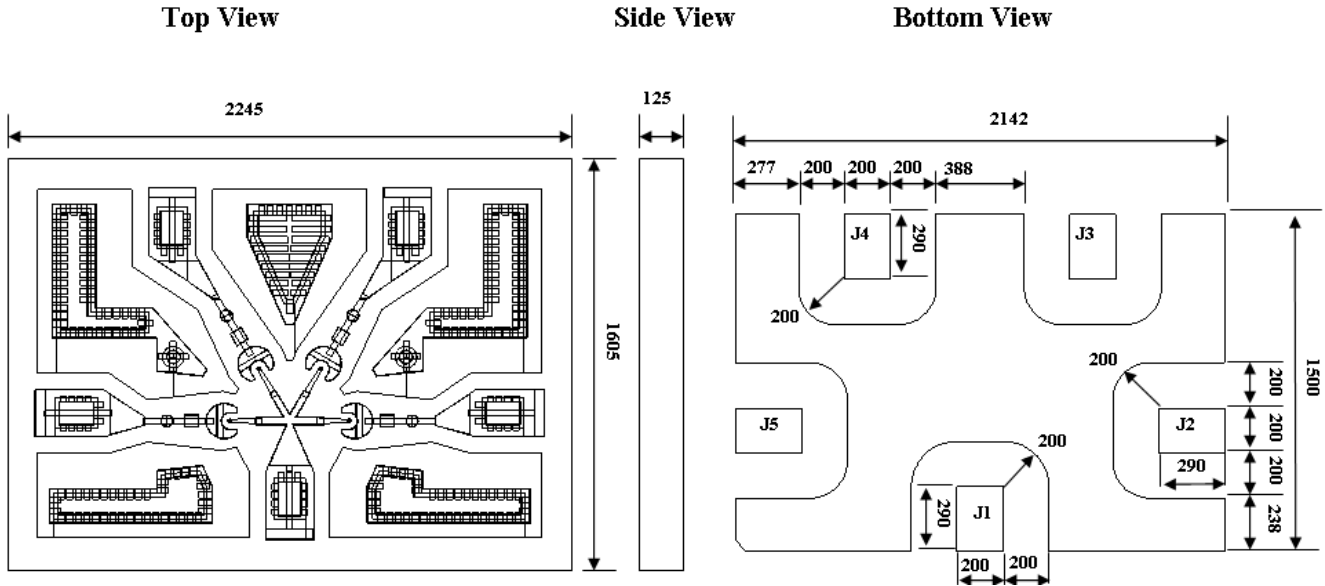

Units in μm

Backside view shows the back metal that is the foot print of the chip and all dimension are +/-0.5um

Ground radius is 200um centered on the I/O Pad.

MASW-004103-1365				
DIM	Inches		mm	
	MIN	MAX	MIN	MAX
Width	0.06220	0.06417	1.580	1.630
Length	0.08740	0.08937	2.220	2.270
Thickness	0.00394	0.00591	0.100	0.150

Handling Procedures

Attachment to a circuit board is made simple through the use of standard surface mount technology. Mounting pads are conveniently located on the bottom surface of these devices and are removed from the active junction locations. These devices are well suited for solder attachment onto hard and soft substrates. The use of 80Au/20Sn, or RoHS compliant solders is recommended. For applications where the average power is $\leq 1W$, conductive silver epoxy may also be used. Cure per manufacturers recommended time and temperature. Typically 1 hour at 150°C.

When soldering these devices to a hard substrate, a solder re-flow method is preferred. A vacuum tip pick-up tool and a force of 60 to 100 grams applied to the top surface of the device while placing the chip is recommended. When soldering to soft substrates, such as Duroid, it is recommended to use a soft solder at the circuit board to mounting pad interface to minimize stress due to any TCE mismatches that may exist. Position the die so that its mounting pads are aligned with the circuit board mounting pads. Solder reflow should not be performed by causing heat to flow through the top surface of the die to the back. Since the HMIC glass is transparent, the edges of the mounting pads can be visually inspected through the die after attachment is completed.

Typical re-flow profiles for Sn60/Pb40 and RoHS compliant solders is provided in [Application Note M538](#), "Surface Mounting Instructions" and can be viewed on the MA-COM Technology Solutions website @ www.macomtech.com

Pocket Tape Information

Carrier Tape Dimensions

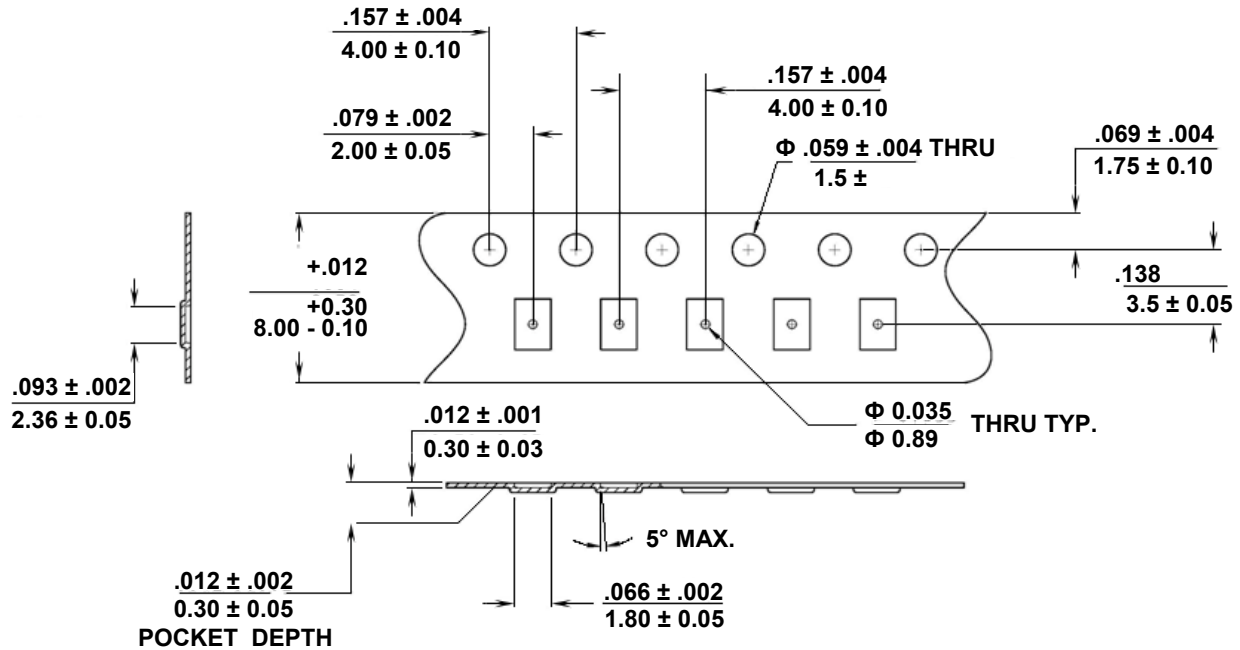

Chip Orientation in Tape

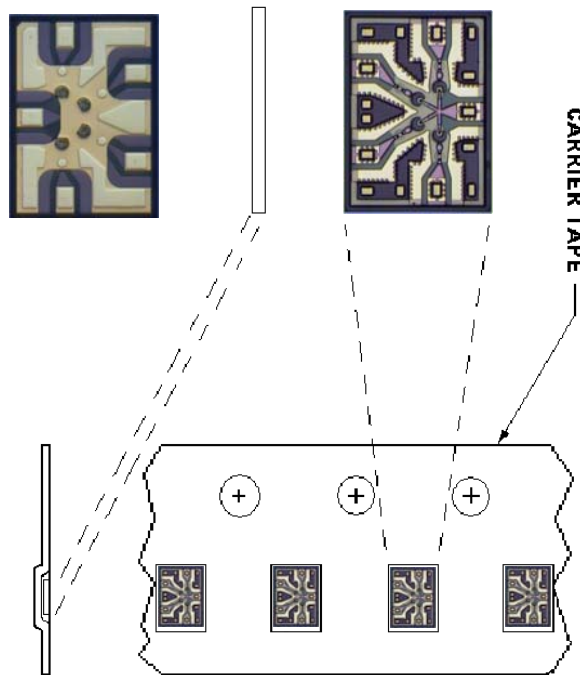

Reel Information

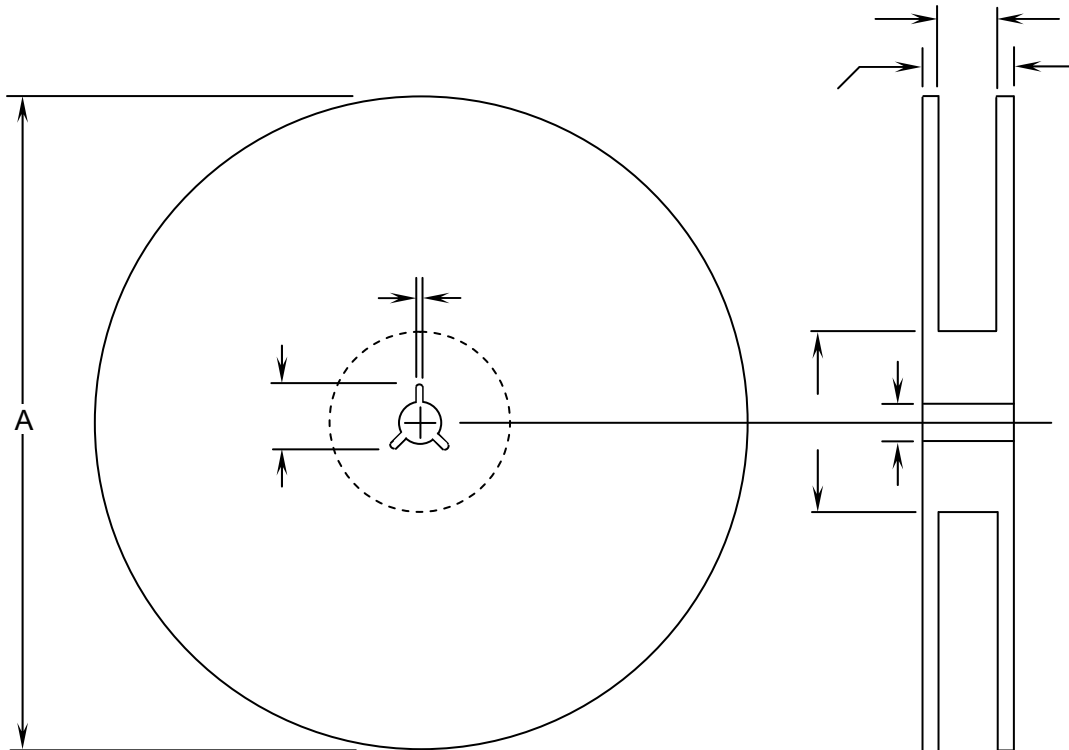

DIM	INCHES		MM	
	MIN.	MAX.	MIN.	MAX.
A	6.980	7.019	177.3	178.3
B	.059	.098	1.5	2.5
C	.504	.520	12.8	13.2
D	.795	.815	20.2	20.7
N	2.146	2.185	54.5	55.5
W ₁	.331	.337	8.4	8.55
W ₂	—	.567	—	14.4