

Xicor X1243 Real Time Clock Oscillator Requirements

By Carlos Martinez, March 1999

Introduction

With any Real Time Clock, there needs to be a quartz crystal controlling the oscillator frequency. This is necessary, because variations of even 20 parts per million in the oscillator frequency result in a clock that is off by almost a minute a month. Typically this oscillator consists of an inverting amplifier and a 32.768 kHz crystal network. The constraints on this oscillator circuit are many. It should:

1. be simple,
2. oscillate at the desired frequency and not vary in frequency over voltage or temperature,
3. readily oscillate on application of power at any operating voltage and temperature.
4. be a “clean” oscillation, with no instabilities that can be interpreted as extra clocks.
5. not consume much current.

Often, meeting one requirement makes it harder to meet another. This application note looks at the Xicor Real Time Clock oscillator circuit and examines the network requirements for maximum coverage of the desired features.

Oscillator Accuracy

The real time clock operates at 32.768 kHz, because this frequency divided by 2^{15} equals one clock per second. The oscillator accuracy depends primarily on providing the proper capacitive load to the crystal oscillator element. A typical quartz crystal oscillator is the CFS-206 from Citizen. This crystal expects a 12.5 pF load for operation at exactly 32.768 kHz. If the load

varies, the oscillator frequency varies. This relationship is shown graphically in Figure 1.

Problems arise when process variations or component tolerances change the capacitive loading, hence affecting frequency accuracy. Since this oscillator provides the timebase for the real time clock counters, any variations in frequency translates into inaccuracies in the measurement of the real time. Xicor’s first Real Time Clock makes use of external components to allow adjustments for greater accuracy.

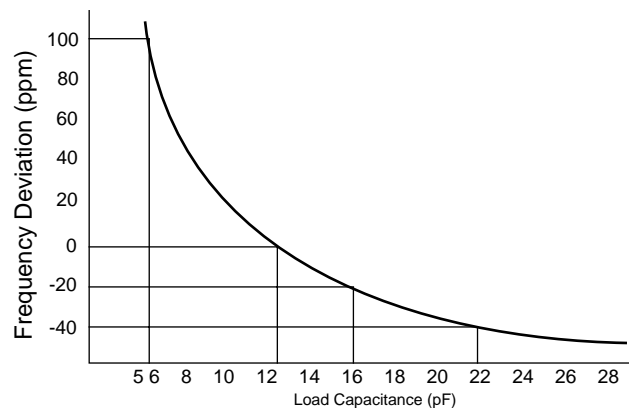

Figure 1. Frequency Accuracy vs. Load Capacitance

Oscillator Network

The Xicor Real Time Clock requires the use of two external resistors and 2 external capacitors in addition to the crystal itself (see Figure 2) The resistors set the level of feedback in the oscillator circuit. The capacitors adjust the loading on the crystal for both stability of the oscillator and proper loading of the crystal element.

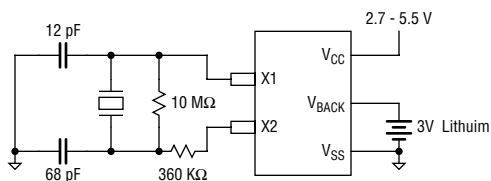

Figure 2. RTC Oscillator Network and Power Supply

For the circuit of Figure 2, the crystal sees the loading of the two capacitors in series. This is represented as:

$$\frac{1}{C_{tot}} = \frac{1}{C1} + \frac{1}{C2}$$

where $C1 = 18 \text{ pF}$ and $C2 = 43 \text{ pF}$. This works out to a loading of 12.7 pF . Similar loading is achieved with $C1 = 18 \text{ pF}$ and $C2 = 39 \text{ pF}$ (12.31 pF) or $C1 = 16 \text{ pF}$ and $C2 = 56 \text{ pF}$ (12.4 pF). A 12.5 pF load capacitance yields an expected error of about 0 ppm

Operating Conditions

The Xicor Real Time Clock is functional over an industrial temperature range (-40°C to $+85^{\circ}\text{C}$). The crystal in an external network, however, typically operates over a much narrower range. Seiko specifies that their crystal operates from -10°C to $+60^{\circ}\text{C}$. Also, as the temperature varies from 25°C , the accuracy of the crystal degrades. Figure 3 shows a frequency-temperature curve for the Seiko VT-200.

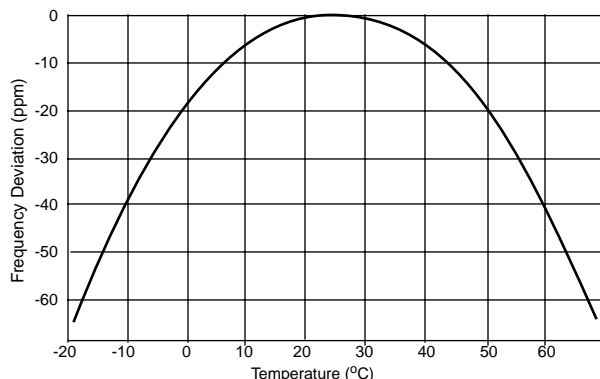

Figure 3. Crystal Frequency-Temperature Curve

This curve shows that changing the temperature by plus or minus 20°C results in a 10 ppm reduction in the frequency of the crystal (and a comparable error in the real time clock reading.) In order to “widen” the temperature range over which there is less than 10 ppm change in frequency, the values of the capacitors in the external network can be changed. For example, the capacitors can be chosen to give a $+10 \text{ ppm}$ error at 25°C . This will effectively shift the curve up, so instead of $\pm 10 \text{ ppm}$ from 7°C to 43°C , there is an accuracy of $\pm 10 \text{ ppm}$ from 0°C to 50°C .

RTC Oscillator characterization

Characterization of the Xicor Real Time Clock indicates that the oscillator frequency changes over temperature with a curve similar to that of the crystal, though the temperature impact is not as great in the circuit as with an individual crystal. There is also a variation in frequency that is dependent on the operating voltage applied to the device. This variation is much less significant than the temperature and is linear with respect to voltage. Characteristic curves over temperature (0°C to 60°C) and voltage are shown in Figure 4.

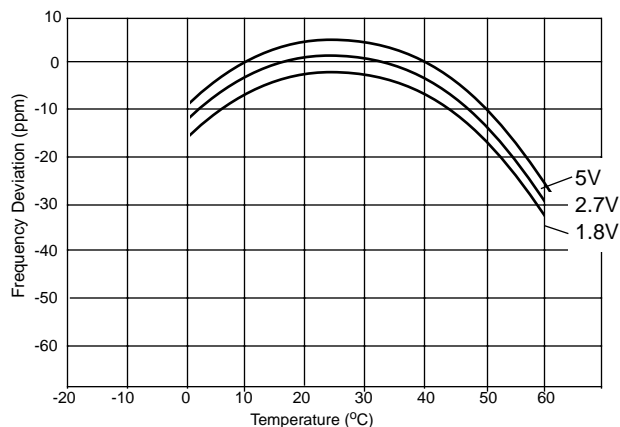

Figure 4. RTC Oscillator Frequency vs. Temperature and Voltage

An alternative to using an external crystal and network is the use of an external temperature controlled crystal oscillator (TCXO) module. Typically this would be used in an application that requires operation over an indus-

trial temperature range or more accuracy over temperature. TCXOs are highly accurate and consume little current.

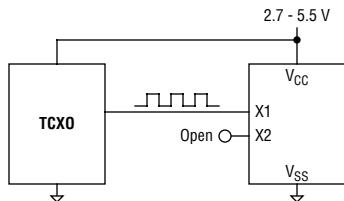

Figure 5. RTC Wiring TCXO

Current Consumption

The current consumption of the real time clock circuit can be an important consideration in the design of a system. The Xicor Real Time Clock device itself consumes very little current. When driven by an external 32.768 kHz oscillator the RTC draws less than 1uA from the supply source. When using the external network, however, the current consumption is somewhat higher. This current consumption is greatly dependant on the power supply voltage and not by the temperature. The curves in Figure 6 show typical current consumption over operating voltage.

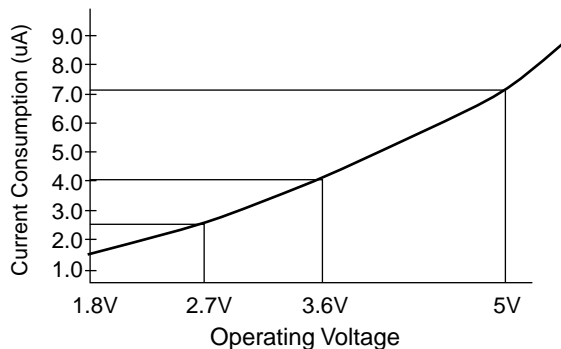

Figure 6. Current Consumption vs. Operating Voltage (recommended external crystal network)

In a typical application (see Figure 2) the main system supply connects to V_{CC} and a primary (non-rechargeable) battery connects to V_{BACK} . When V_{CC} is greater than V_{BACK} , an internal switch from the battery is open and no current flows out of the battery. When V_{CC} fails,

the real time clock circuits automatically connect to the backup supply source. A common backup battery is a Lithium type that provides between 3V and 2V. An Energizer CR2032 Lithium battery provides 225 mAHr (from 3V down to 2V) and would maintain the time and date in the Xicor RTC for a cumulative 10 years of main power failure.

Alternatively, a supercapacitor can be used to provide voltage to the clock during main power failures. A supercap can provide several days of operation during a power outage and does not pose the environmental or manufacturing problems of lithium batteries. Since the capacitor needs to be charged, an external diode is required in the circuit as shown in Figure 7.

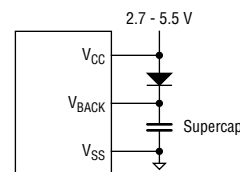

Figure 7. Use of a supercap for V_{BACK}

Supercaps are available with capacities to 1 F and above. Using a standard capacitor discharge equation, with the following assumptions, Table 1 shows maximum duration of a power outage that various supercaps can maintain the RTC.

This capability is often all that is required.

$$i = C \frac{dV}{dt}$$

$$dV = 4.3V \text{ to } 1.8V$$

$$i = 3.5\mu A \text{ (average current from 4.3V to 1.8V)}$$

Table 1: RTC operating time using a SuperCap

Capacitance	Power Outage Duration	Capacitor Physical Size ^[1]
0.1 F	0.8 days	12.5mm diameter, 5.5mm height
0.22 F	1.8 days	
0.47 F	3.9 days	20mm diameter, 6mm height
1.0 F	8.3 days	

1. Panasonic SG series Gold Capacitors

Board Layout

While Xicor's Real Time Clock is less sensitive to board layout than some clocks, there is still reason to be cautious in the layout of the external components. The problem exists because of the internal threshold levels on the X1 input are necessarily narrow. Noise on the X1 pin can therefore cause oscillations as the input comparator tries to track the noise. These oscillations are perceived as additional clocks, so the RTC appears to run fast. While there are many ways to implement this layout, one suggestion is provided in Figure 8. This layout includes a bypass capacitor from V_{CC} to V_{SS} and a pull-up resistor ($4.3\text{ k}\Omega$) on the $\overline{\text{IRQ}}$ output. Not included are pull up resistors on the SDA and SCL lines.

Summary

The Xicor Real Time Clock integrates a clock calendar, alarm, battery backup circuit, EEPROM and (in some versions) a CPU Supervisor into a single package, however the primary role of this device is to maintain the real time. To do this, a crystal controlled oscillator provides an accurate timebase. By using external components, this oscillator achieves better than ± 30 seconds a month accuracy over 0°C to 50°C and consumes so little current the clock operates for up to 10 years from a single lithium battery.

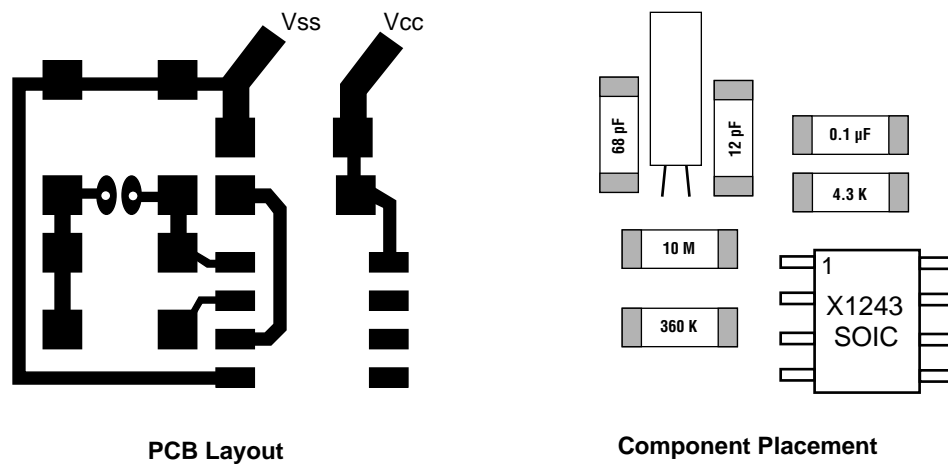

Figure 8. PCB Layout for X1243