

M61528FP

SCF TYPE FIXED EQUALIZER FOR CAR AUDIO

REJ03F0040-0101Z

Rev.1.1

Dec.17.2003

Features

- Fixed equalizer(3 bands equalizer with SCF)
 - 4 independent fixed equalizer controls.
 - Reduce the external C,R parts by using SCF (Switched Capacitor Filter) technology.
- FADER
 - 4 independent fader controls.
 - 0dB to $-50\text{dB}/2\text{dBstep}$, $-\infty\text{dB}$
 - Built-in Soft-changing circuit for switching-noise.

Application

- Car Audio

Recommended Operating Condition

- Supply voltage range 7.0V to 9.0V
- Rated supply voltage 8.0V

System Configurations

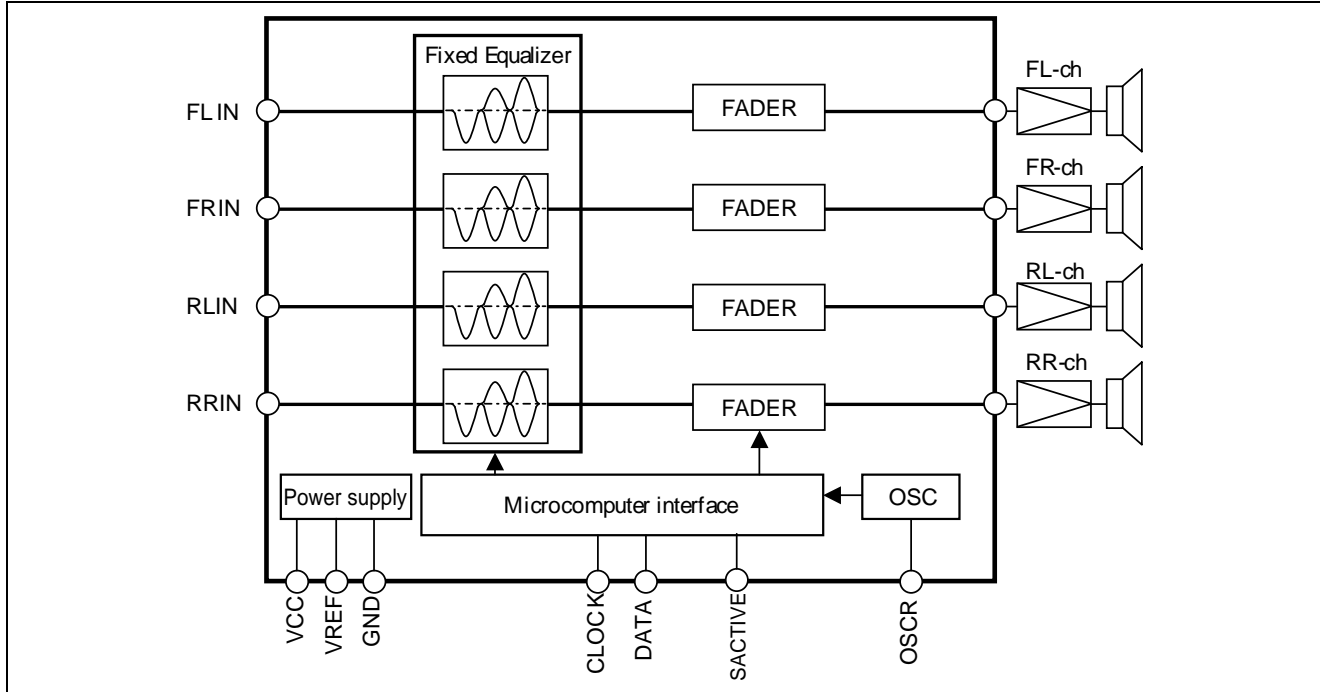

Function

- Fixed equalizer

Frequency

range	Center frequency f0[Hz]	Control range	Quality factor Q	Note.
Low	120, 150, 200, 300	0dB to -8dB / 0.5dB step	FRONT : 1.5 to 3.0 / 0.5 step REAR : 2.0 to 4.0 / 0.5 step	4 independent each equalizer controls.
Mid	800, 1.2K, 1.5K, 2K, 3K	+4dB to -8dB / 0.5dB step	0.8 to 2.0 / 0.2 step	
High	8K, 10K, 18K	+8dB to -8dB / 0.5dB step	0.4 to 1.0 / 0.2 step	

- FADER
 - 0dB to -50dB / 2dB , -∞dB (4 independent fader controls)
 - The Soft-changing can work in gain step by 2dB.
 - Refer to 15 page for Soft-changing.

Pin configuration(top view)

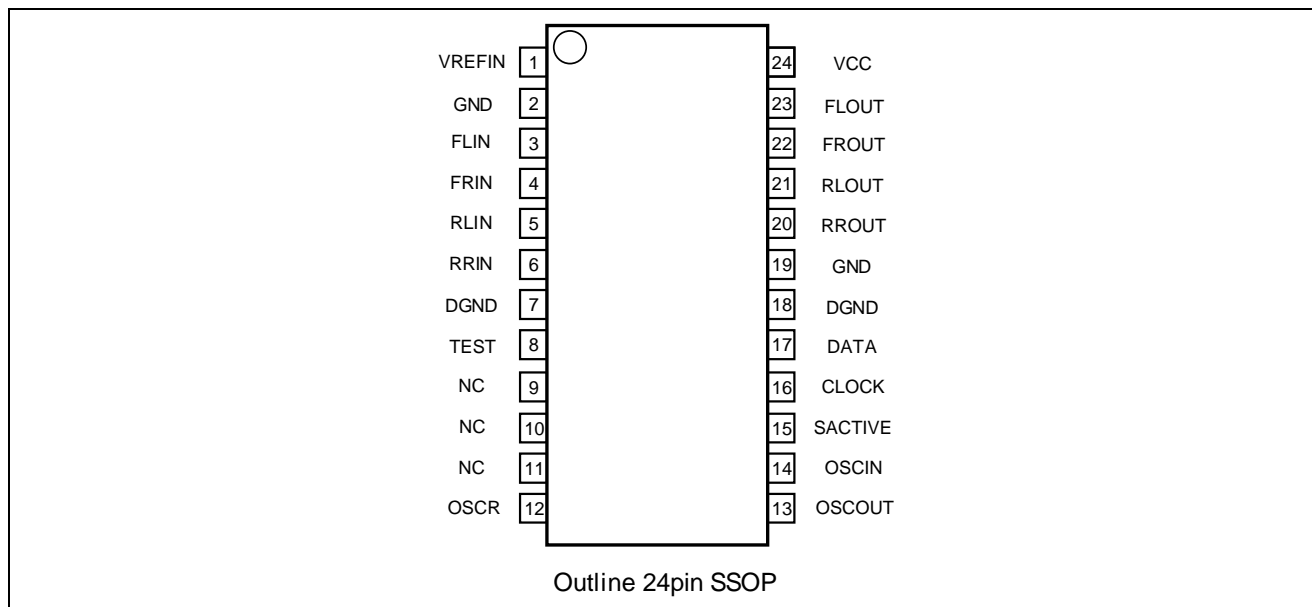

Pin Description

Pin No.	Name	Function
3	FLIN	Input pin of FRONT L channel
4	FRIN	Input pin of FRONT R channel
5	RLIN	Input pin of REAR L channel
6	RRIN	Input pin of REAR R channel
23	FLOUT	Output pin of FRONT L channel
22	FROUT	Output pin of FRONT R channel
21	RLOUT	Output pin of REAR L channel
20	RROUT	Output pin of REAR R channel
2,19	GND	Analog ground pin
7,18	DGND	Digital ground pin
24	VCC	Power supply pin
1	VREFIN	Signal ground of IC
8	TEST	TEST pin
15	SACTIVE	Output pin of soft-changing ACTIVE signal
14	OSCIN	Buffer input pin for the ceramics oscillation
13	OSCOU	Buffer output pin for the ceramics oscillation
12	OSCR	Input pin for the inside oscillation
17	DATA	Input pin of Serial DATA
16	CLOCK	Input pin of CLOCK
9 to 11	N.C	Non – connection pin

Absolute Maximum Ratings

Symbol	Parameter	Condition	Ratings	Unit
VCC	Power supply		10.5	V
Pd	Power dissipation	Ta ≤ 25 °C	1.0	W
K	Thermal derating	Ta > 25 °C (Circuit board installation)	10	mW/°C
Topr	Operating temperature		-30 to +85	°C
Tstg	Storage temperature		-55 to +125	°C

Recommended Operating Conditions

Symbol	Parameter	Ratings			Unit
		MIN	TYP	MAX	
VCC	Power supply	7.0	8.0	9.0	V
VIH	Logic “H” level input voltage(16,17pin)	2.7	—	5.0	
VIL	Logic “L” level input voltage(16,17pin)	GND	—	0.7	

Thermal derating

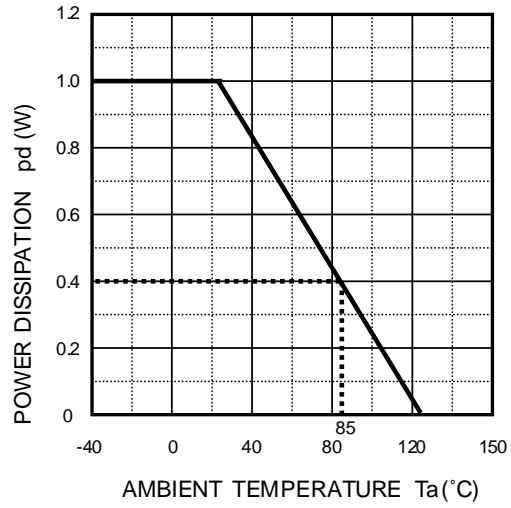

Electrical Characteristics

Unless otherwise noted, VCC=8V, Ta=25 °C, Vi=1Vrms, f=1KHz, Fixed EQ(Low/Mid/High)=0dB, FADER=0dB, RL=10K Ω,

Symbol	Parameter	Condition	Limits			Unit
			min	typ	max	
Characteristics						
Icc	Circuit current	No signal	—	40	55	mA
Gv	Pass gain	20Hz to 20KHz	-2.0	0	-2.0	dB
Sc	Channel separation	Input side: Vi=1Vrms, f=1KHz, Measurement side: Input pin to GND with the capacitance DIN-AUDIO	70	85	—	dB
Vo max	Maximum output voltage	400Hz to 30KHz BPF THD=1%	1.8	2.2	—	Vrms
THD	Total harmonic distortion	400Hz to 30KHz BPF	—	0.01	0.03	%
Vno	Output noise voltage	Input pin to GND with the capacitance, DIN-AUDIO	—	10	18	μVrms
		Input pin to GND with the capacitance, DIN-AUDIO, FADER=-∞dB	—	3.5	10	
Zin	Input resistance	3, 4, 5, 6 pin	10	20	30	KΩ
Fixed EQ(Low)						
Gv(Cut)	Control range(Cut)	Gv=-8dB, f0=300Hz, Q=2.0 Vi=1Vrms, f=300Hz	-9.5	-8.0	-6.5	dB
f0	Center frequency	Gv=-8dB, f0=120Hz, Q=2.0	102	120	138	Hz
		Gv=-8dB, f0=150Hz, Q=2.0	127.5	150	172.5	
		Gv=-8dB, f0=200Hz, Q=2.0	170	200	230	
		Gv=-8dB, f0=300Hz, Q=2.0	255	300	345	
Q	Quality factor	1.5 Gv=-8dB, f0=300Hz, Q=1.5 (FRONT only)	1.275	1.5	1.725	
		Gv=-8dB, f0=300Hz, Q=2.0	1.7	2.0	2.3	
		Gv=-8dB, f0=300Hz, Q=2.5	2.125	2.5	2.875	
		Gv=-8dB, f0=300Hz, Q=3.0	2.55	3.0	3.45	
		Gv=-8dB, f0=300Hz, Q=3.5 (REAR only)	2.975	3.5	4.025	
		Gv=-8dB, f0=300Hz, Q=4.0 (REAR only)	3.4	4.0	4.6	

M61528FP

Unless otherwise noted ,
VCC=8V, Ta=25 °C, Vi=1Vrms, f=1KHz, Fixed EQ(Low/Mid/High)=0dB, FADER=0dB, RL=10K Ω, At the time of use of a ceramics oscillator.

Symbol	Parameter	Condition	Limits			Unit
			min	typ	max	
Fixed EQ(Mid)						
Gv(Boost)	Control range(Boost)	Vi=0.1Vrms,f=3KHz Gv=+4dB,f0=3KHz,Q=1.0	+2.8	+4.0	+5.2	dB
Gv(Cut)	Control range(Cut)	Gv=-8dB,f0=3KHz,Q=1.0 Vi=1Vrms,f=3KHz	-9.5	-8.0	-6.5	dB
f0	Center frequency	Gv=-8dB,f0=800Hz,Q=1.0	0.68	0.8	0.92	KHz
		Gv=-8dB,f0=1.2KHz,Q=1.0	1.02	1.2	1.38	
		Gv=-8dB,f0=1.5KHz,Q=1.0	1.275	1.5	1.725	
		Gv=-8dB,f0=2.0KHz,Q=1.0	1.7	2.0	2.3	
		Gv=-8dB,f0=3.0KHz,Q=1.0	2.55	3.0	3.45	
Q	Quality factor	Gv=-8dB,f0=3.0KHz,Q=0.8	0.68	0.8	0.92	
		Gv=-8dB,f0=3.0KHz,Q=1.0	0.85	1.0	1.15	
		Gv=-8dB,f0=3.0KHz,Q=1.2	1.02	1.2	1.38	
		Gv=-8dB,f0=3.0KHz,Q=1.4	1.19	1.4	1.61	
		Gv=-8dB,f0=3.0KHz,Q=1.6	1.36	1.6	1.84	
		Gv=-8dB,f0=3.0KHz,Q=1.8	1.53	1.8	2.07	
		Gv=-8dB,f0=3.0KHz,Q=2.0	1.7	2.0	2.3	
Fixed EQ(High)						
Gv(Boost)	Control range(Boost)	Gv=+8dB,f0=8KHz,Q=1.0 Vi=0.1Vrms,f=8KHz	+6.5	+8.0	+9.5	dB
Gv(Cut)	Control range(Cut)	Gv=-8dB,f0=8KHz,Q=1.0 Vi=1Vrms,f=8KHz	-9.5	-8.0	-6.5	dB
f0	Center frequency	Gv=-8dB,f0=8KHz,Q=1.0	6.8	8	9.2	KHz
		Gv=-8dB,f0=10KHz,Q=1.0	8.5	10	11.5	
		Gv=-8dB,f0=18KHz,Q=1.0	15.3	18	20.7	
Q	Quality factor	Gv=-8dB,f0=8KHz,Q=0.4	0.34	0.4	0.46	
		Gv=-8dB,f0=8KHz,Q=0.6	0.51	0.6	0.69	
		Gv=-8dB,f0=8KHz,Q=0.8	0.68	0.8	0.92	
		Gv=-8dB,f0=8KHz,Q=1.0	0.85	1.0	1.15	
FADER						
ATT max	Maximum attenuation	FADER=-∞dB , DIN-AUDIO	80	90	—	dB
ΔATT	Attenuation error	ATT=0dB	-2.0	0	+2.0	dB

Fixed Equalizer Frequency Characteristic

(1) Frequency characteristics of Low (This characteristics is a simulation result.)

- Gain control : 0dB to -8dB / 0.5dB ($f_0=120\text{Hz}$, $Q=2.0$ setting)
(FRONT and REAR are the same characteristics.)

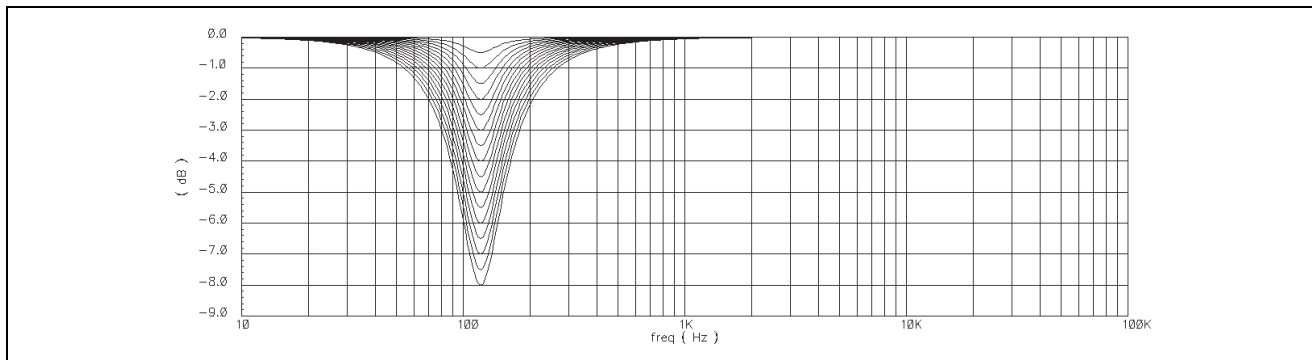

- Center frequency : 120Hz / 150Hz / 200Hz / 300Hz ($G_v=-8\text{dB}$, $Q=2.0$ setting)
(FRONT and REAR are the same characteristics.)

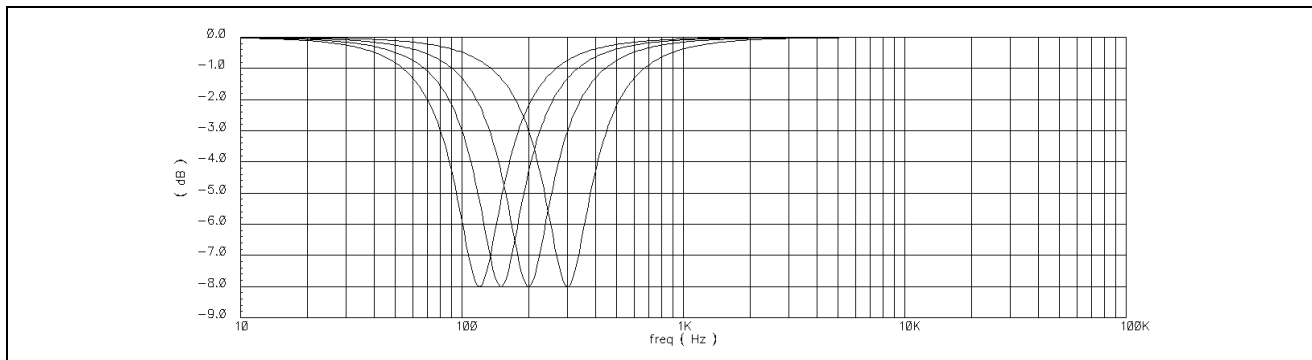

- Quality factor

FRONT characteristics : 1.5 / 2.0 / 2.5 / 3.0 ($G_v=-8\text{dB}$, $f_0=120\text{Hz}$ setting)

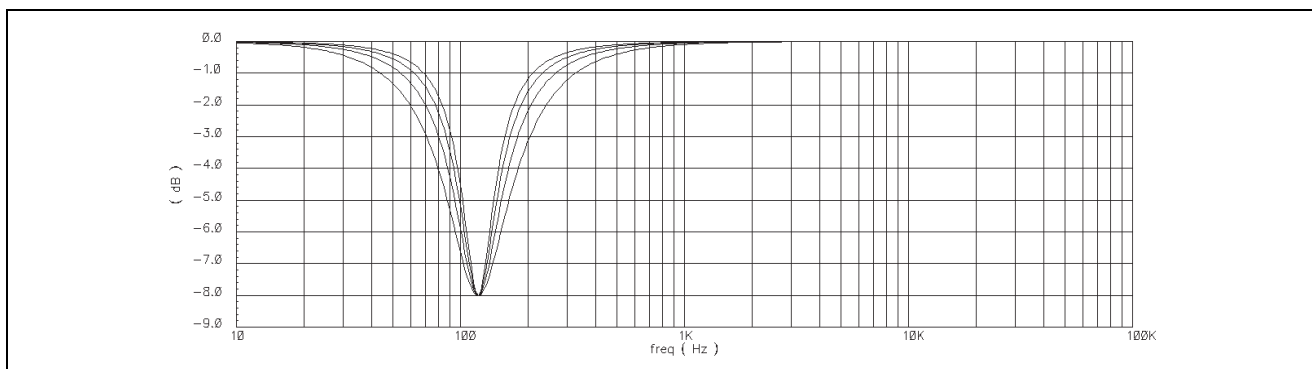

REAR characteristics : 2.0 / 2.5 / 3.0 / 3.5 / 4.0 (Gv=-8dB, f0=120Hz setting)

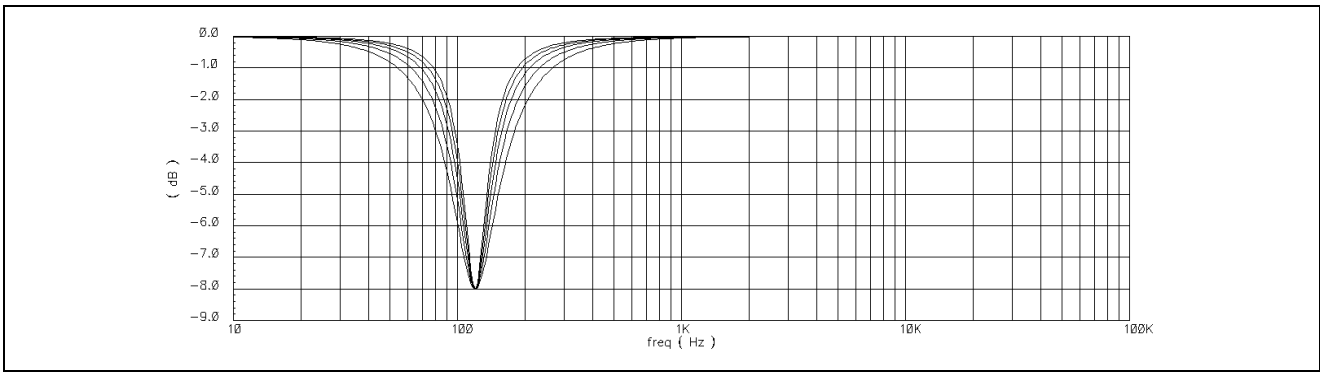

(2) Frequency characteristics of Mid (This characteristics is a simulation result.)

- Gain control : +4dB to -8dB / 0.5dB (f0=1.2KHz, Q=1.0 setting)

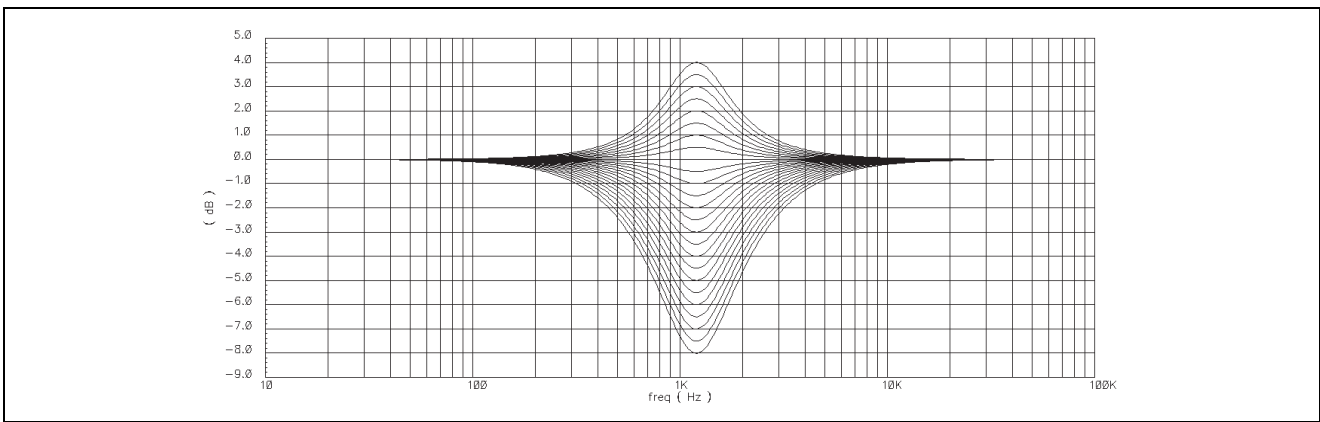

- Center frequency : 800Hz / 1.2KHz / 1.5KHz / 2.0KHz / 3.0KHz (Gv=-8dB, Q=1.0 setting)

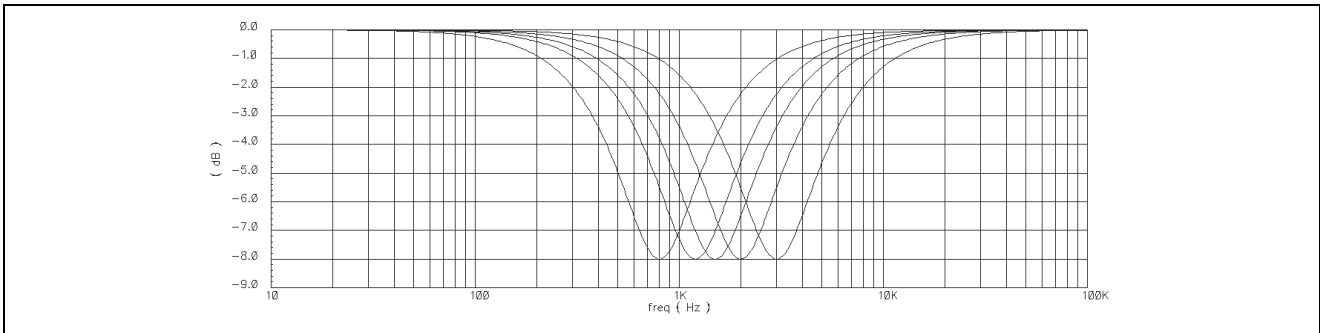

- Quality factor : 0.8 / 1.0 / 1.2 / 1.4 / 1.6 / 1.8 / 2.0 ($G_v = -8\text{dB}$, $f_0 = 1.2\text{KHz}$ setting)

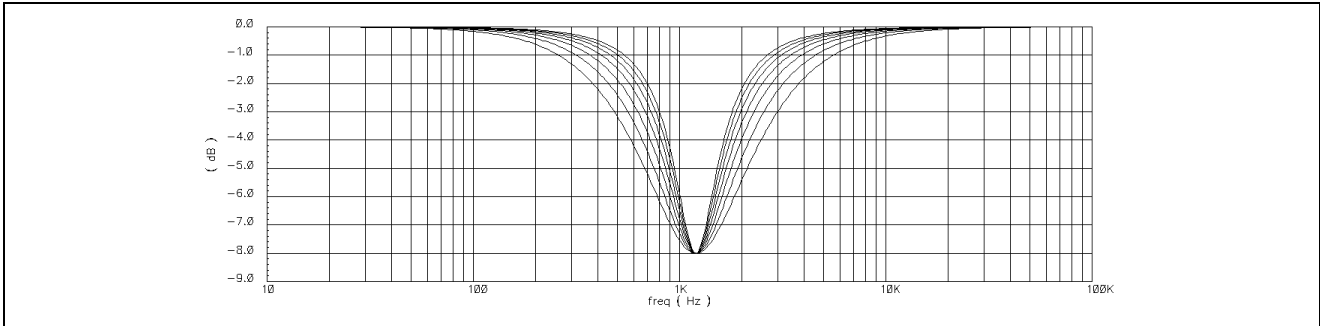

(3) Frequency characteristics of High (This characteristics is a simulation result.)

- Gain control : +8dB to -8dB / 0.5dB ($f_0 = 10\text{KHz}$, $Q = 1.0$ setting)

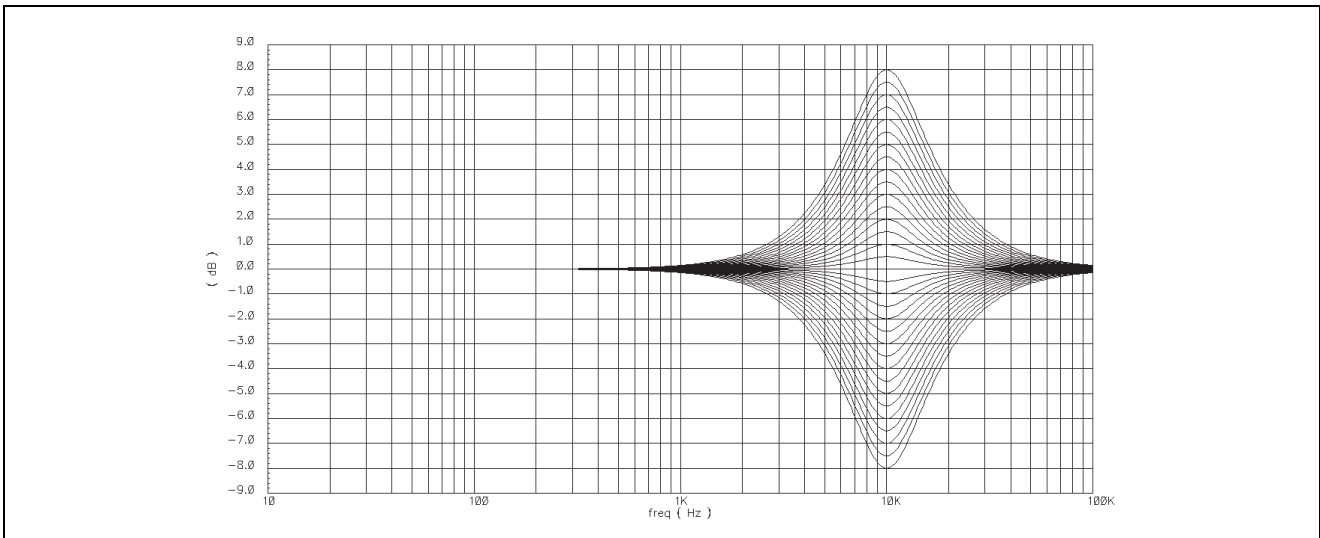

- Center frequency : 8KHz / 10KHz / 18KHz ($G_v = +8\text{dB}$, $Q = 1.0$ setting)

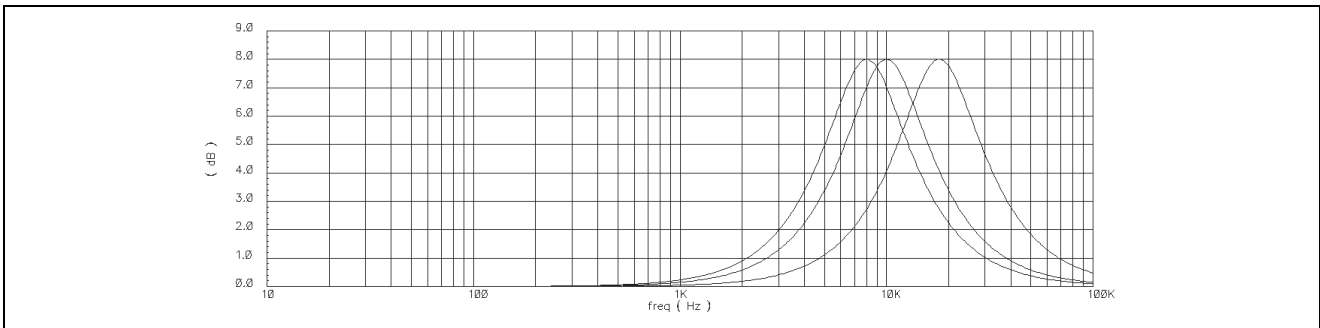

- Quality factor : 0.4 / 0.6 / 0.8 / 1.0 (Gv=+8dB, f0=10KHz setting)

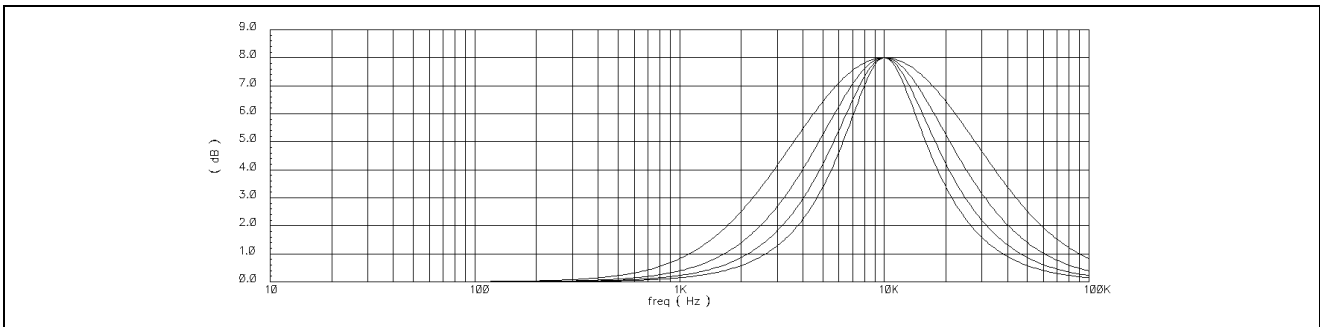

Power on Reset

This IC builds in the power on reset function.

The voltage of VCC (24 pin) less than 5.0V, the serial DATA can not accept.

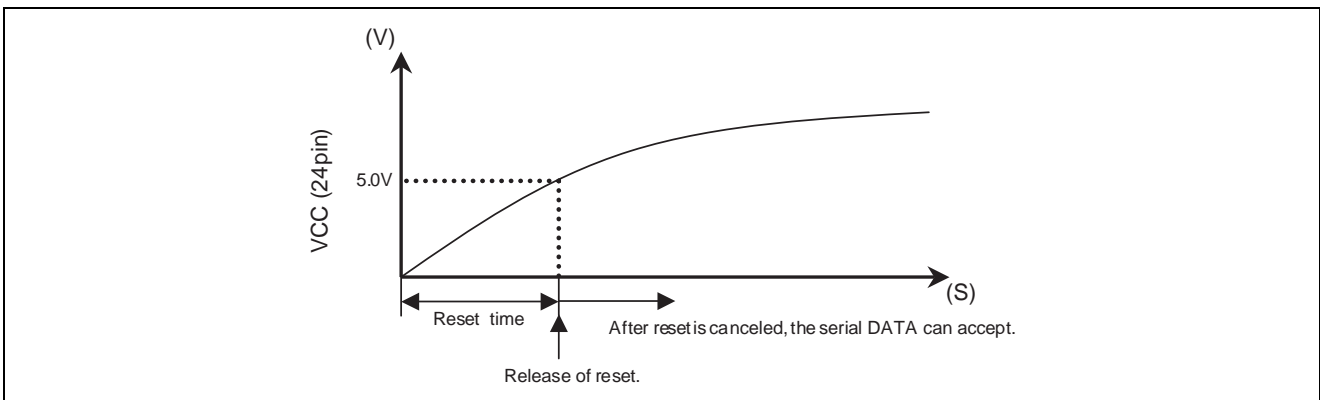

Relationship Between Data and Clock

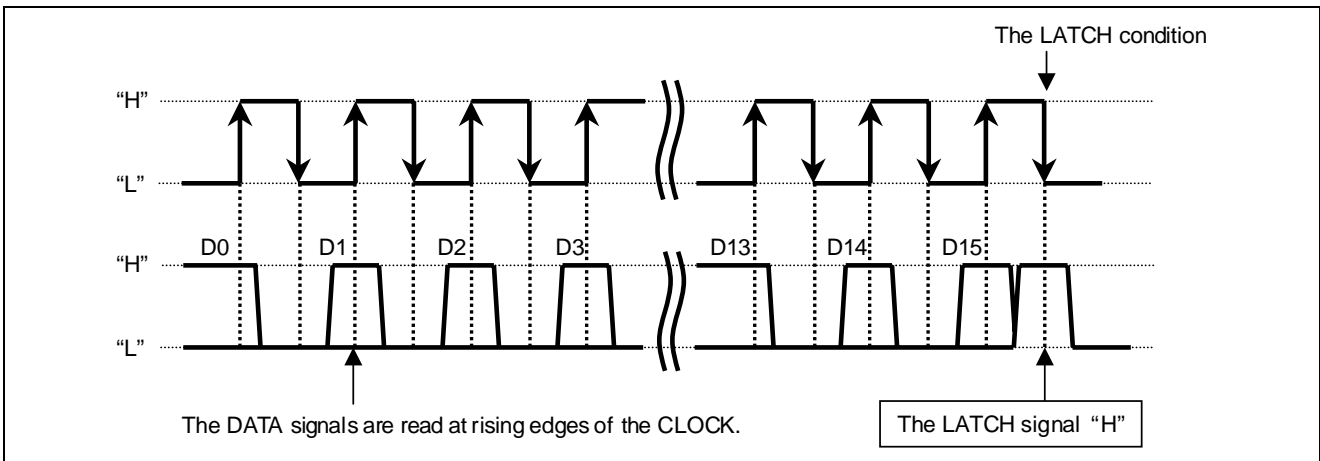

How to transmit DATA.

This IC reads DATA signal at the rising edge of the CLOCK.

When DATA are transmitted, setting up the DATA line is always "L" when the falling edge of the CLOCK.

Clock and Data Timings

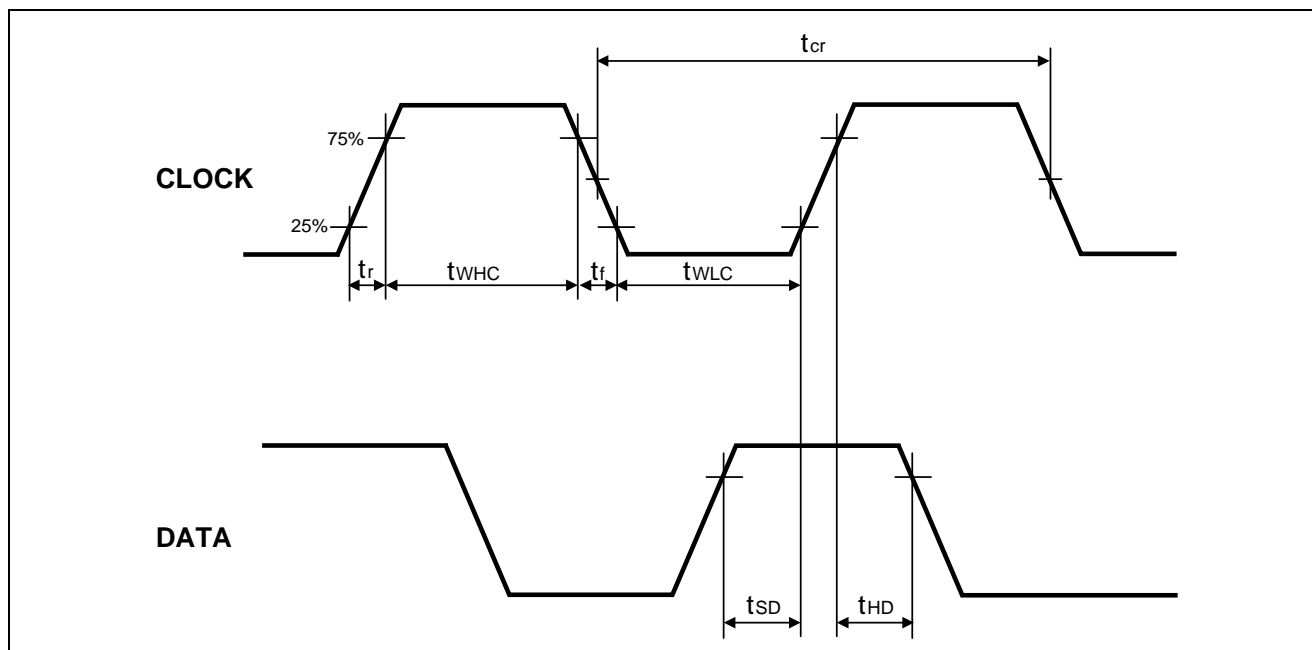

Timing Definition of Digital Block

Symbol	Parameter	Limits			Unit
		MIN	TYP	MAX	
t_{cr}	CLOCK cycle time	4.0	—	—	μS
t_{WHC}	CLOCK pulse width ("H" level)	1.6	—	—	
t_{WLC}	CLOCK pulse width ("L" level)	1.6	—	—	
t_r	Rising time of CLOCK	—	—	0.4	
t_f	Falling time of CLOCK	—	—	0.4	
t_{SD}	DATA setup time	0.8	—	—	
t_{HD}	DATA hold time	0.8	—	—	

Data Control Specification

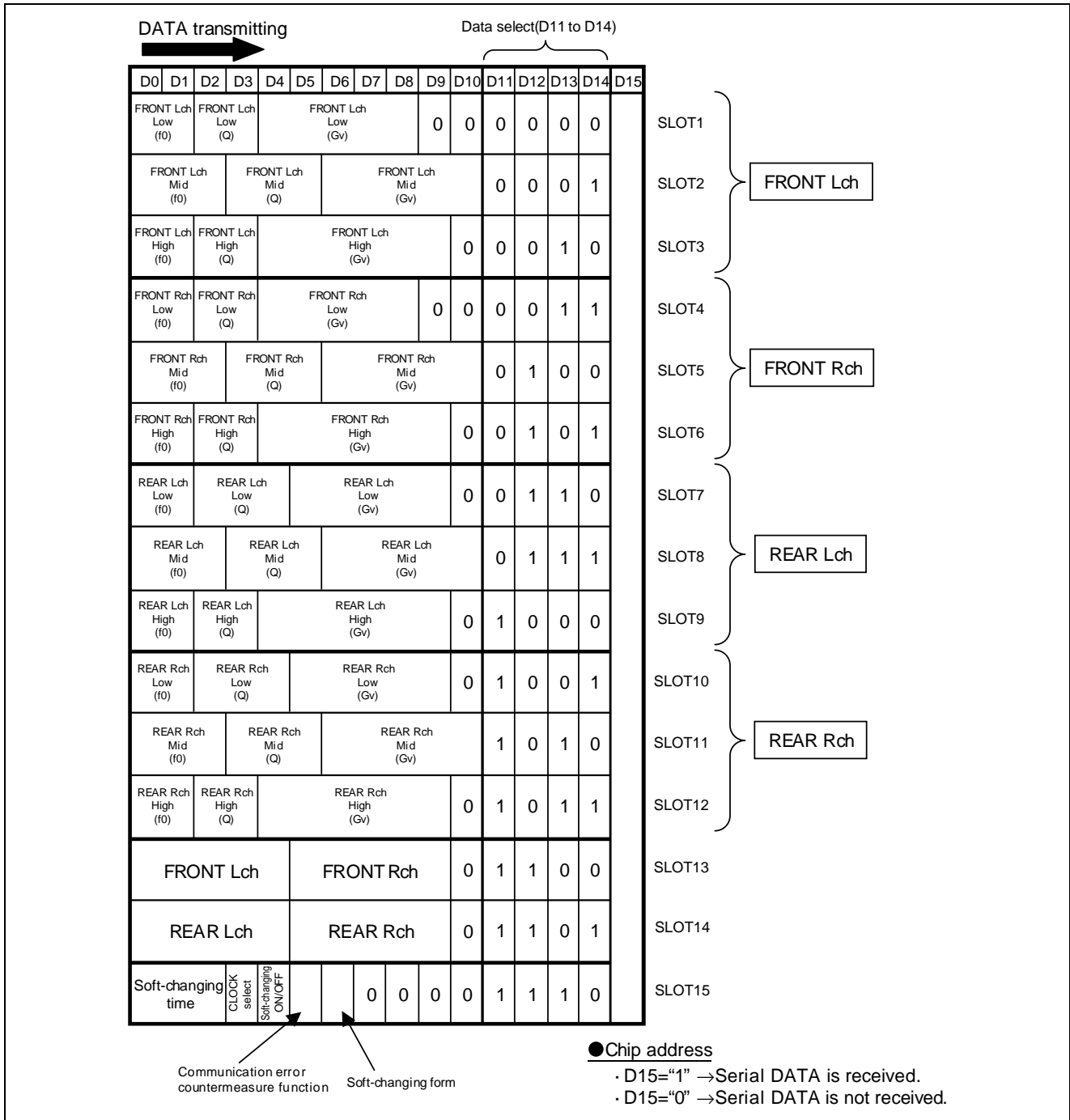

Data Transmission of Fixed Equalizer Setting

- Faulty operation in the communication error occurrence.
Fixed equalizer setting premise no-change setting after setting is done once.
By this premise, A noise countermeasure circuit of the setting change isn't built in.
Therefore, It has the possibility that noise is made by communication error.
These countermeasures are taken by this IC as it is shown in next page.
— Fixed equalizer setting change in the communication error occurrence.(example)

[Transmitting data of normal.]

SLOT 1, f0 setting: 300Hz, Q setting: 3.0, **Gv setting: -8.0dB**

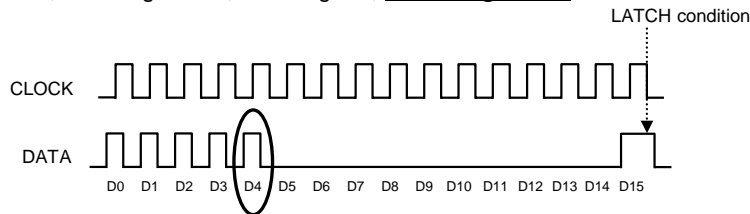

Communication error occurrence.

[Transmitting data of communication error.]

SLOT 1, f0 setting: 300Hz, Q setting: 3.0, **Gv setting: 0dB**

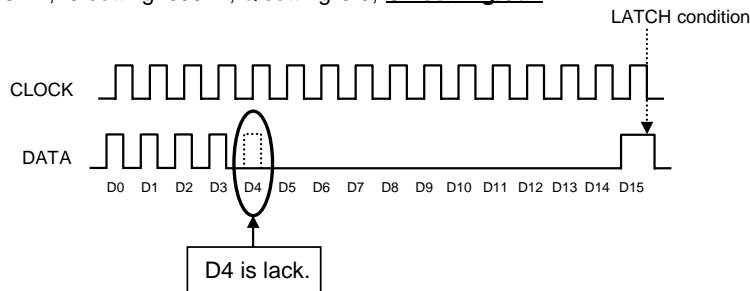

* In the case of the upper figure, Fixed equalizer gain setting of FRONT Lch low range

Gv= -8.0dB ⇒ Gv= 0dB

occur faulty operation, and it has the possibility that noise is made.

- A communication error countermeasure function from the microcomputer.

This IC has the function which changes a set up of an inside when the same data were continued twice and it was received to reduce the occurrence probability of the above communication error. This function is possible to effective or ineffective change by serial data.

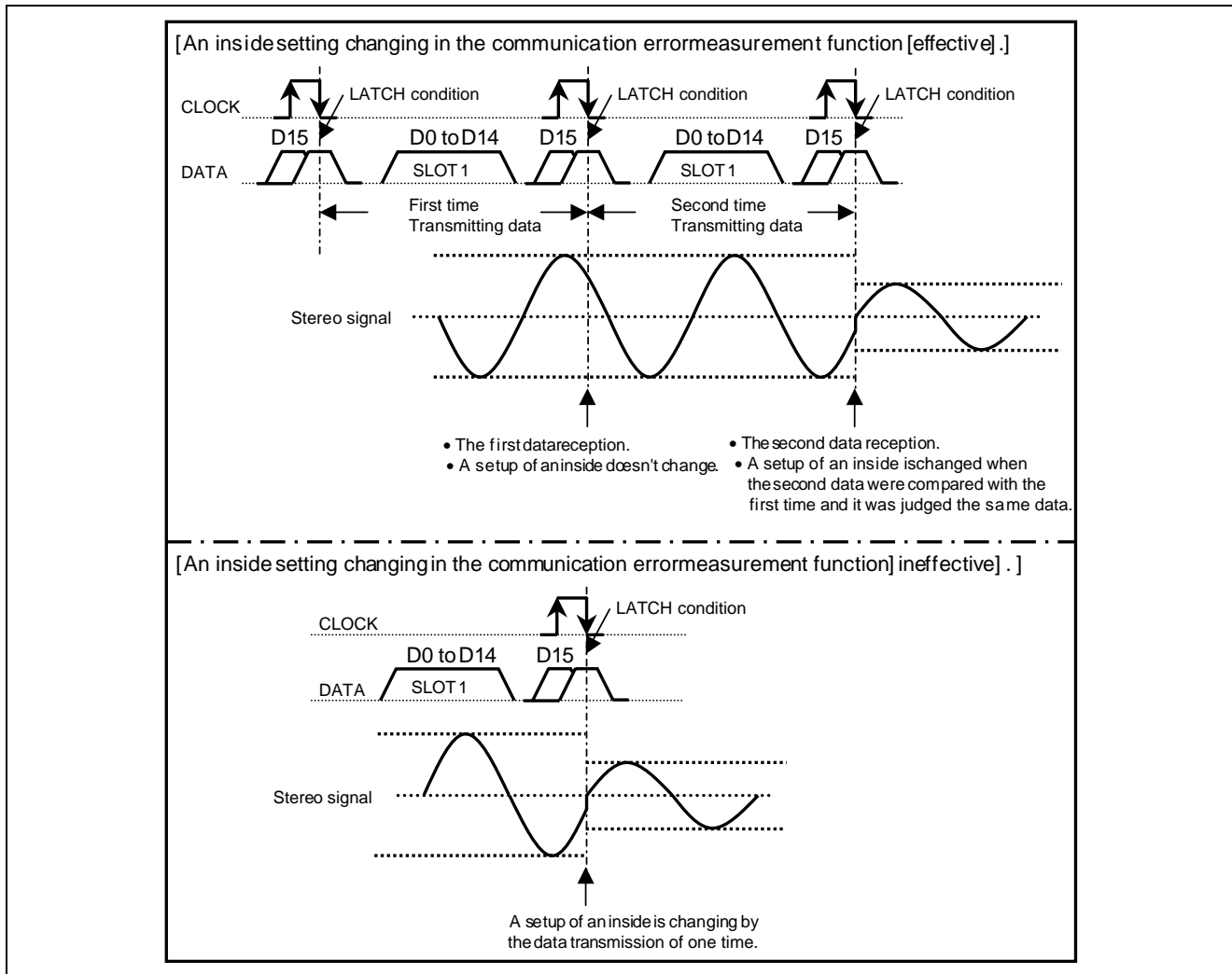

- The precaution of the communication error countermeasure function.
 - (1) Communication error measurement function are function when are slot1 to slot12(Fixed equalizer setting) transmitting.
 - (2) A communication error countermeasure function is [effective] at the time of the power supply injection. when you don't use a communication error countermeasure function,setting it up [ineffective] with serial data after the power supply injection. (Switching of effective or ineffective is possible with D5 of the slot 15.)
 - (3) At the time of communication error measurement function [effective] ,Slot1 to slot12 transmit data of same slot twice by the continuance.
 - (4) Transmit LATCH condition in every transmitting data of one time.

Soft-Changing

This IC built in the Soft-changing circuit for reduce the step-noise of Fader when internal switch changing.

By this function, Switching noise of no-signal and some signals can be reduced.

- SOFT-CHANGING 1

This is the circuit which changes gain smoothly at the setup time.

This function can work as follows,

- (1) At the time of Soft-changing ON.
- (2) Slot15/D6=0
- (3) After the last Soft-changing is completed.

For example, the movement when Fader is changed from 0dB to -6dB is shown in the right figure(ex.1).

After this IC receive the data of fader:-6dB , this circuit changes fader setting from 0dB to -6dB at a time.

Switching time is the time when it was set up with Soft-changing time.

(ex. 1) Fader : 0dB→-6dB changing. Soft-changing time : 33ms

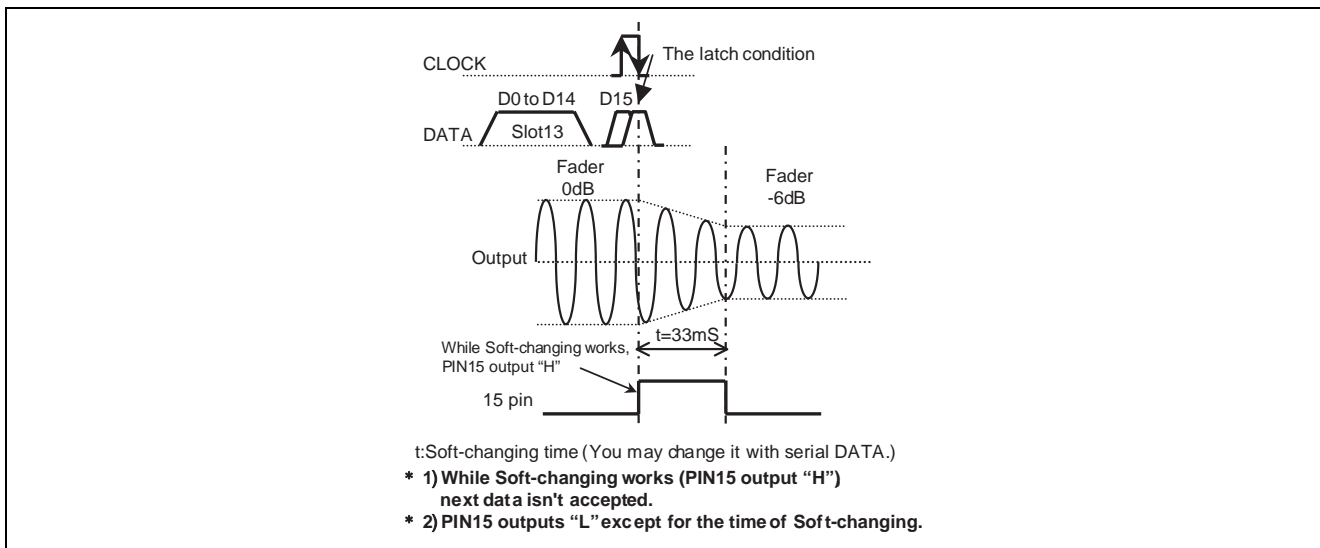

Soft-Changing Time

Time	D0	D1	D2
83mS(41.5mS)	1	1	1/0
66mS(33mS)	1	0	1/0
41mS(20.5mS)	0	1	1/0
33mS(16.5mS)	0	0	1/0

The change of the Soft-changing time is possible by the setting of D2.

- D2="1" : The left time of the left table.
(Soft-changing time : 83mS,66mS,41mS,33mS)
- D2="0" : The right time of the left table
(Soft-changing time : 41.5mS,33mS,20.5mS,16.5mS)

• **SOFT-CHANGING 2**

This is the circuit which changes gain by 2dB step.

This function can work as follows,

- (1) At the time of Soft-changing ON.
- (2) Slot15/D6=1
- (3) After the last Soft-changing is completed.

For example, the movement when Fader is changed from 0dB to -6dB is shown in the right figure(ex.2).

After this IC receive the data of fader: -6dB,

“ 0dB ” ⇒ “ -2dB ” ⇒ “ -4dB ” ⇒ “ -6dB ”

this circuit changes fader setting from 0dB to -6dB by 2dB step.

Switching time is the time when it was set up with Soft-changing time.

Total changing time is as the follows.

Total changing time=Soft-changing time × the number of the step

In the case of the right figure, total changing time is 99mS. (33mS × 3 steps)

When Soft-changing time is long, step noise is more reduced. Because the step noise is has relations with Soft-changing time. We recommend SOFT-CHANGING 2.

However, please confirm step noise by listening test, and judge it.

(ex. 2) Fader : 0dB→-6dB changing. Soft-changing time : 33ms

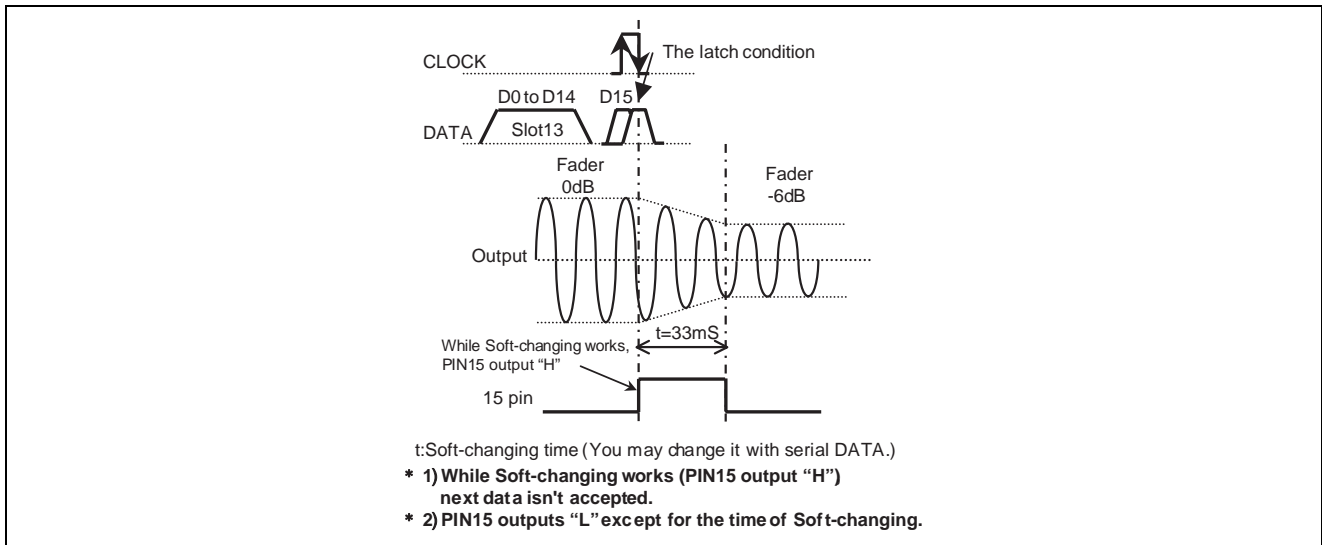

Data Transmission and the Relation of the Soft-Changing Time

This IC has the function which should make the following Serial DATA ineffective to the soft-changing movement completion after LATCH condition detection.

(At the time of a slot 13 and the slot 14 transmission of the DATA input format.)

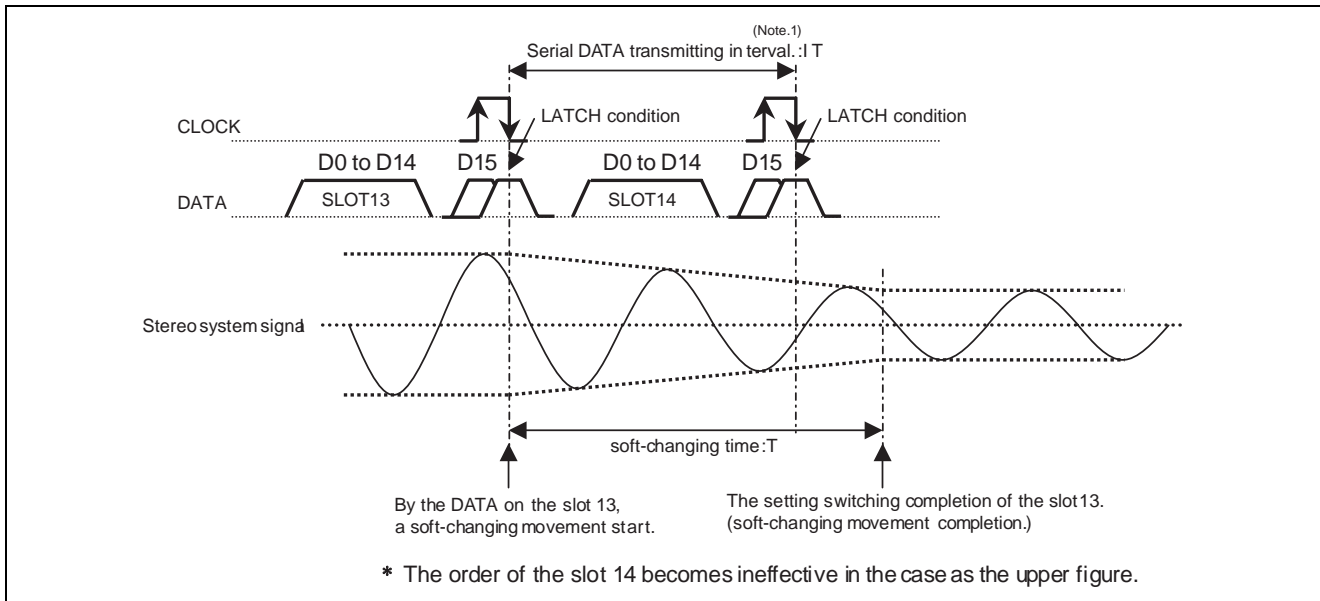

- In to make the Serial DATA transmitting interval IT from MCU(microcomputer)to M61528FP

Serial DATA transmitting interval : $IT >$ soft-changing time : T

the reading error of the DATA doesn't occur.

- DATA transmitting example

The DATA transmitting interval when it was set up with the Soft-changing time = 33mS(Internal oscillator using).

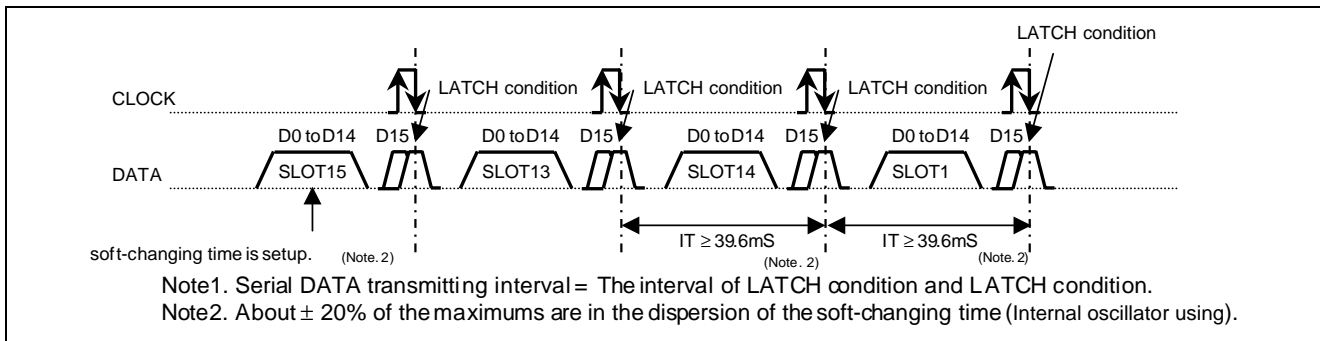

SLOT1(FRONT Lch low range)

FRONT Low
(f0)

f0	D0	D1
300Hz	1	1
200Hz	1	0
150Hz	0	1
● 120Hz	0	0

FRONT Low
(Q)

Q	D2	D3
3.0	1	1
2.5	1	0
2.0	0	1
● 1.5	0	0

FRONT Low (Gv)

Gv	D4	D5	D6	D7	D8
● 0dB	0	0	0	0	0
-0.5dB	1	0	0	0	1
-1.0dB	1	0	0	1	0
-1.5dB	1	0	0	1	1
-2.0dB	1	0	1	0	0
-2.5dB	1	0	1	0	1
-3.0dB	1	0	1	1	0
-3.5dB	1	0	1	1	1
-4.0dB	1	1	0	0	0
-4.5dB	1	1	0	0	1
-5.0dB	1	1	0	1	0
-5.5dB	1	1	0	1	1
-6.0dB	1	1	1	0	0
-6.5dB	1	1	1	0	1
-7.0dB	1	1	1	1	0
-7.5dB	1	1	1	1	1
-8.0dB	1	0	0	0	0

SLOT2(FRONT Lch middle range)

FRONT Mid
(f0)

f0	D0	D1	D2
3.0KHz	1	0	0
2.0KHz	0	1	1
1.5KHz	0	1	0
1.2KHz	0	0	1
● 800Hz	0	0	0

FRONT Mid
(Q)

Q	D3	D4	D5
2.0	1	1	0
1.8	1	0	1
1.6	1	0	0
1.4	0	1	1
1.2	0	1	0
1.0	0	0	1
● 0.8	0	0	0

FRONT Mid (Gv)

Gv	D6	D7	D8	D9	D10
+4.0dB	0	1	0	0	0
+3.5dB	0	0	1	1	1
+3.0dB	0	0	1	1	0
+2.5dB	0	0	1	0	1
+2.0dB	0	0	1	0	0
+1.5dB	0	0	0	1	1
+1.0dB	0	0	0	1	0
+0.5dB	0	0	0	0	1
● 0dB	0	0	0	0	0
-0.5dB	1	0	0	0	1
-1.0dB	1	0	0	1	0
-1.5dB	1	0	0	1	1
-2.0dB	1	0	1	0	0
-2.5dB	1	0	1	0	1
-3.0dB	1	0	1	1	0
-3.5dB	1	0	1	1	1
-4.0dB	1	1	0	0	0
-4.5dB	1	1	0	0	1
-5.0dB	1	1	0	1	0
-5.5dB	1	1	0	1	1
-6.0dB	1	1	1	0	0
-6.5dB	1	1	1	0	1
-7.0dB	1	1	1	1	0
-7.5dB	1	1	1	1	1
-8.0dB	1	0	0	0	0

● It's initial setting when VCC turn on.

SLOT3(FRONT Lch high range)

FRONT High
(f0)

f0	D0	D1
18KHz	1	0
10KHz	0	1
● 8KHz	0	0

FRONT High
(Q)

Q	D2	D3
1.0	1	1
0.8	1	0
0.6	0	1
● 0.4	0	0

FRONT High (Gv)

Gv	D4	D5	D6	D7	D8	D9
+8.0dB	0	1	0	0	0	0
+7.5dB	0	0	1	1	1	1
+7.0dB	0	0	1	1	1	0
+6.5dB	0	0	1	1	0	1
+6.0dB	0	0	1	1	0	0
+5.5dB	0	0	1	0	1	1
+5.0dB	0	0	1	0	1	0
+4.5dB	0	0	1	0	0	1
+4.0dB	0	0	1	0	0	0
+3.5dB	0	0	0	1	1	1
+3.0dB	0	0	0	1	1	0
+2.5dB	0	0	0	1	0	1
+2.0dB	0	0	0	1	0	0
+1.5dB	0	0	0	0	1	1
+1.0dB	0	0	0	0	1	0
+0.5dB	0	0	0	0	0	1
● 0dB	0	0	0	0	0	0
-0.5dB	1	0	0	0	0	1
-1.0dB	1	0	0	0	1	0
-1.5dB	1	0	0	0	1	1
-2.0dB	1	0	0	1	0	0
-2.5dB	1	0	0	1	0	1
-3.0dB	1	0	0	1	1	0
-3.5dB	1	0	0	1	1	1
-4.0dB	1	0	1	0	0	0
-4.5dB	1	0	1	0	0	1
-5.0dB	1	0	1	0	1	0
-5.5dB	1	0	1	0	1	1
-6.0dB	1	0	1	1	0	0
-6.5dB	1	0	1	1	0	1
-7.0dB	1	0	1	1	1	0
-7.5dB	1	0	1	1	1	1
-8.0dB	1	1	0	0	0	0

● It's initial setting when VCC turn on.

SLOT4(FRONT Rch low range)

FRONT Low (f0)

f0	D0	D1
300Hz	1	1
200Hz	1	0
150Hz	0	1
● 120Hz	0	0

FRONT Low (Q)

Q	D2	D3
3.0	1	1
2.5	1	0
2.0	0	1
● 1.5	0	0

FRONT Low (Gv)

Gv	D4	D5	D6	D7	D8
● 0dB	0	0	0	0	0
-0.5dB	1	0	0	0	1
-1.0dB	1	0	0	1	0
-1.5dB	1	0	0	1	1
-2.0dB	1	0	1	0	0
-2.5dB	1	0	1	0	1
-3.0dB	1	0	1	1	0
-3.5dB	1	0	1	1	1
-4.0dB	1	1	0	0	0
-4.5dB	1	1	0	0	1
-5.0dB	1	1	0	1	0
-5.5dB	1	1	0	1	1
-6.0dB	1	1	1	0	0
-6.5dB	1	1	1	0	1
-7.0dB	1	1	1	1	0
-7.5dB	1	1	1	1	1
-8.0dB	1	0	0	0	0

SLOT5(FRONT Rch middle range)

FRONT Mid (f0)

f0	D0	D1	D2
3.0KHz	1	0	0
2.0KHz	0	1	1
1.5KHz	0	1	0
1.2KHz	0	0	1
● 800Hz	0	0	0

FRONT Mid (Q)

Q	D3	D4	D5
2.0	1	1	0
1.8	1	0	1
1.6	1	0	0
1.4	0	1	1
1.2	0	1	0
1.0	0	0	1
● 0.8	0	0	0

FRONT Mid (Gv)

Gv	D6	D7	D8	D9	D10
+4.0dB	0	1	0	0	0
+3.5dB	0	0	1	1	1
+3.0dB	0	0	1	1	0
+2.5dB	0	0	1	0	1
+2.0dB	0	0	1	0	0
+1.5dB	0	0	0	1	1
+1.0dB	0	0	0	1	0
+0.5dB	0	0	0	0	1
● 0dB	0	0	0	0	0
-0.5dB	1	0	0	0	1
-1.0dB	1	0	0	1	0
-1.5dB	1	0	0	1	1
-2.0dB	1	0	1	0	0
-2.5dB	1	0	1	0	1
-3.0dB	1	0	1	1	0
-3.5dB	1	0	1	1	1
-4.0dB	1	1	0	0	0
-4.5dB	1	1	0	0	1
-5.0dB	1	1	0	1	0
-5.5dB	1	1	0	1	1
-6.0dB	1	1	1	0	0
-6.5dB	1	1	1	0	1
-7.0dB	1	1	1	1	0
-7.5dB	1	1	1	1	1
-8.0dB	1	0	0	0	0

● It's initial setting when VCC turn on.

SLOT6(FRONT Rch high range)

FRONT High
(f0)

f0	D0	D1
18KHz	1	0
10KHz	0	1
● 8KHz	0	0

FRONT High
(Q)

Q	D2	D3
1.0	1	1
0.8	1	0
0.6	0	1
● 0.4	0	0

FRONT High (Gv)

Gv	D4	D5	D6	D7	D8	D9
+8.0dB	0	1	0	0	0	0
+7.5dB	0	0	1	1	1	1
+7.0dB	0	0	1	1	1	0
+6.5dB	0	0	1	1	0	1
+6.0dB	0	0	1	1	0	0
+5.5dB	0	0	1	0	1	1
+5.0dB	0	0	1	0	1	0
+4.5dB	0	0	1	0	0	1
+4.0dB	0	0	1	0	0	0
+3.5dB	0	0	0	1	1	1
+3.0dB	0	0	0	1	1	0
+2.5dB	0	0	0	1	0	1
+2.0dB	0	0	0	1	0	0
+1.5dB	0	0	0	0	1	1
+1.0dB	0	0	0	0	1	0
+0.5dB	0	0	0	0	0	1
● 0dB	0	0	0	0	0	0
-0.5dB	1	0	0	0	0	1
-1.0dB	1	0	0	0	1	0
-1.5dB	1	0	0	0	1	1
-2.0dB	1	0	0	1	0	0
-2.5dB	1	0	0	1	0	1
-3.0dB	1	0	0	1	1	0
-3.5dB	1	0	0	1	1	1
-4.0dB	1	0	1	0	0	0
-4.5dB	1	0	1	0	0	1
-5.0dB	1	0	1	0	1	0
-5.5dB	1	0	1	0	1	1
-6.0dB	1	0	1	1	0	0
-6.5dB	1	0	1	1	0	1
-7.0dB	1	0	1	1	1	0
-7.5dB	1	0	1	1	1	1
-8.0dB	1	1	0	0	0	0

● It's initial setting when VCC turn on.

SLOT7(REAR Lch Low range)

REAR Low
(f0)

f0	D0	D1
300Hz	1	1
200Hz	1	0
150Hz	0	1
● 120Hz	0	0

REAR Low
(Q)

Q	D2	D3	D4
4.0	1	0	0
3.5	0	1	1
3.0	0	1	0
2.5	0	0	1
● 2.0	0	0	0

REAR Low (Gv)

Gv	D5	D6	D7	D8	D9
● 0dB	0	0	0	0	0
-0.5dB	1	0	0	0	1
-1.0dB	1	0	0	1	0
-1.5dB	1	0	0	1	1
-2.0dB	1	0	1	0	0
-2.5dB	1	0	1	0	1
-3.0dB	1	0	1	1	0
-3.5dB	1	0	1	1	1
-4.0dB	1	1	0	0	0
-4.5dB	1	1	0	0	1
-5.0dB	1	1	0	1	0
-5.5dB	1	1	0	1	1
-6.0dB	1	1	1	0	0
-6.5dB	1	1	1	0	1
-7.0dB	1	1	1	1	0
-7.5dB	1	1	1	1	1
-8.0dB	1	0	0	0	0

SLOT8(REAR Lch middle range)

REAR Mid
(f0)

f0	D0	D1	D2
3.0KHz	1	0	0
2.0KHz	0	1	1
1.5KHz	0	1	0
1.2KHz	0	0	1
● 800Hz	0	0	0

REAR Mid
(Q)

Q	D3	D4	D5
2.0	1	1	0
1.8	1	0	1
1.6	1	0	0
1.4	0	1	1
1.2	0	1	0
1.0	0	0	1
● 0.8	0	0	0

REAR Mid (Gv)

Gv	D6	D7	D8	D9	D10
+4.0dB	0	1	0	0	0
+3.5dB	0	0	1	1	1
+3.0dB	0	0	1	1	0
+2.5dB	0	0	1	0	1
+2.0dB	0	0	1	0	0
+1.5dB	0	0	0	1	1
+1.0dB	0	0	0	1	0
+0.5dB	0	0	0	0	1
● 0dB	0	0	0	0	0
-0.5dB	1	0	0	0	1
-1.0dB	1	0	0	1	0
-1.5dB	1	0	0	1	1
-2.0dB	1	0	1	0	0
-2.5dB	1	0	1	0	1
-3.0dB	1	0	1	1	0
-3.5dB	1	0	1	1	1
-4.0dB	1	1	0	0	0
-4.5dB	1	1	0	0	1
-5.0dB	1	1	0	1	0
-5.5dB	1	1	0	1	1
-6.0dB	1	1	1	0	0
-6.5dB	1	1	1	0	1
-7.0dB	1	1	1	1	0
-7.5dB	1	1	1	1	1
-8.0dB	1	0	0	0	0

● It's initial setting when VCC turn on.

SLOT9(REAR Lch high range)

REAR High
(f0)

f0	D0	D1
18KHz	1	0
10KHz	0	1
● 8KHz	0	0

REAR High
(Q)

Q	D2	D3
1.0	1	1
0.8	1	0
0.6	0	1
● 0.4	0	0

REAR High (Gv)

Gv	D4	D5	D6	D7	D8	D9
+8.0dB	0	1	0	0	0	0
+7.5dB	0	0	1	1	1	1
+7.0dB	0	0	1	1	1	0
+6.5dB	0	0	1	1	0	1
+6.0dB	0	0	1	1	0	0
+5.5dB	0	0	1	0	1	1
+5.0dB	0	0	1	0	1	0
+4.5dB	0	0	1	0	0	1
+4.0dB	0	0	1	0	0	0
+3.5dB	0	0	0	1	1	1
+3.0dB	0	0	0	1	1	0
+2.5dB	0	0	0	1	0	1
+2.0dB	0	0	0	1	0	0
+1.5dB	0	0	0	0	1	1
+1.0dB	0	0	0	0	1	0
+0.5dB	0	0	0	0	0	1
● 0dB	0	0	0	0	0	0
-0.5dB	1	0	0	0	0	1
-1.0dB	1	0	0	0	1	0
-1.5dB	1	0	0	0	1	1
-2.0dB	1	0	0	1	0	0
-2.5dB	1	0	0	1	0	1
-3.0dB	1	0	0	1	1	0
-3.5dB	1	0	0	1	1	1
-4.0dB	1	0	1	0	0	0
-4.5dB	1	0	1	0	0	1
-5.0dB	1	0	1	0	1	0
-5.5dB	1	0	1	0	1	1
-6.0dB	1	0	1	1	0	0
-6.5dB	1	0	1	1	0	1
-7.0dB	1	0	1	1	1	0
-7.5dB	1	0	1	1	1	1
-8.0dB	1	1	0	0	0	0

● It's initial setting when VCC turn on.

SLOT10(REAR Rch Low range)

REAR Low
(f0)

f0	D0	D1
300Hz	1	1
200Hz	1	0
150Hz	0	1
● 120Hz	0	0

REAR Low
(Q)

Q	D2	D3	D4
4.0	1	0	0
3.5	0	1	1
3.0	0	1	0
2.5	0	0	1
● 2.0	0	0	0

REAR Low(Gv)

Gv	D5	D6	D7	D8	D9
● 0dB	0	0	0	0	0
-0.5dB	1	0	0	0	1
-1.0dB	1	0	0	1	0
-1.5dB	1	0	0	1	1
-2.0dB	1	0	1	0	0
-2.5dB	1	0	1	0	1
-3.0dB	1	0	1	1	0
-3.5dB	1	0	1	1	1
-4.0dB	1	1	0	0	0
-4.5dB	1	1	0	0	1
-5.0dB	1	1	0	1	0
-5.5dB	1	1	0	1	1
-6.0dB	1	1	1	0	0
-6.5dB	1	1	1	0	1
-7.0dB	1	1	1	1	0
-7.5dB	1	1	1	1	1
-8.0dB	1	0	0	0	0

SLOT11(REAR Rch middle range)

REAR Mid
(f0)

f0	D0	D1	D2
3.0KHz	1	0	0
2.0KHz	0	1	1
1.5KHz	0	1	0
1.2KHz	0	0	1
● 800Hz	0	0	0

REAR Mid
(Q)

Q	D3	D4	D5
2.0	1	1	0
1.8	1	0	1
1.6	1	0	0
1.4	0	1	1
1.2	0	1	0
1.0	0	0	1
● 0.8	0	0	0

REAR Mid (Gv)

Gv	D6	D7	D8	D9	D10
+4.0dB	0	1	0	0	0
+3.5dB	0	0	1	1	1
+3.0dB	0	0	1	1	0
+2.5dB	0	0	1	0	1
+2.0dB	0	0	1	0	0
+1.5dB	0	0	0	1	1
+1.0dB	0	0	0	1	0
+0.5dB	0	0	0	0	1
● 0dB	0	0	0	0	0
-0.5dB	1	0	0	0	1
-1.0dB	1	0	0	1	0
-1.5dB	1	0	0	1	1
-2.0dB	1	0	1	0	0
-2.5dB	1	0	1	0	1
-3.0dB	1	0	1	1	0
-3.5dB	1	0	1	1	1
-4.0dB	1	1	0	0	0
-4.5dB	1	1	0	0	1
-5.0dB	1	1	0	1	0
-5.5dB	1	1	0	1	1
-6.0dB	1	1	1	0	0
-6.5dB	1	1	1	0	1
-7.0dB	1	1	1	1	0
-7.5dB	1	1	1	1	1
-8.0dB	1	0	0	0	0

● It's initial setting when VCC turn on.

SLOT12(REAR Rch high range)

REAR High
(f0)

f0	D0	D1
18KHz	1	0
10KHz	0	1
● 8KHz	0	0

REAR High
(Q)

Q	D2	D3
1.0	1	1
0.8	1	0
0.6	0	1
● 0.4	0	0

REAR High (Gv)

Gv	D4	D5	D6	D7	D8	D9
+8.0dB	0	1	0	0	0	0
+7.5dB	0	0	1	1	1	1
+7.0dB	0	0	1	1	1	0
+6.5dB	0	0	1	1	0	1
+6.0dB	0	0	1	1	0	0
+5.5dB	0	0	1	0	1	1
+5.0dB	0	0	1	0	1	0
+4.5dB	0	0	1	0	0	1
+4.0dB	0	0	1	0	0	0
+3.5dB	0	0	0	1	1	1
+3.0dB	0	0	0	1	1	0
+2.5dB	0	0	0	1	0	1
+2.0dB	0	0	0	1	0	0
+1.5dB	0	0	0	0	1	1
+1.0dB	0	0	0	0	1	0
+0.5dB	0	0	0	0	0	1
● 0dB	0	0	0	0	0	0
-0.5dB	1	0	0	0	0	1
-1.0dB	1	0	0	0	1	0
-1.5dB	1	0	0	0	1	1
-2.0dB	1	0	0	1	0	0
-2.5dB	1	0	0	1	0	1
-3.0dB	1	0	0	1	1	0
-3.5dB	1	0	0	1	1	1
-4.0dB	1	0	1	0	0	0
-4.5dB	1	0	1	0	0	1
-5.0dB	1	0	1	0	1	0
-5.5dB	1	0	1	0	1	1
-6.0dB	1	0	1	1	0	0
-6.5dB	1	0	1	1	0	1
-7.0dB	1	0	1	1	1	0
-7.5dB	1	0	1	1	1	1
-8.0dB	1	1	0	0	0	0

● It's initial setting when VCC turn on.

SLOT13

FADER(FRONT)

ATT	FRONT Lch	D0	D1	D2	D3	D4
	FRONT Rch	D5	D6	D7	D8	D9
0dB	1	1	0	1	0	
-2dB	1	1	0	0	1	
-4dB	1	1	0	0	0	
-6dB	1	0	1	1	1	
-8dB	1	0	1	1	0	
-10dB	1	0	1	0	1	
-12dB	1	0	1	0	0	
-14dB	1	0	0	1	1	
-16dB	1	0	0	1	0	
-18dB	1	0	0	0	1	
-20dB	1	0	0	0	0	
-22dB	0	1	1	1	1	
-24dB	0	1	1	1	0	
-26dB	0	1	1	0	1	
-28dB	0	1	1	0	0	
-30dB	0	1	0	1	1	
-32dB	0	1	0	1	0	
-34dB	0	1	0	0	1	
-36dB	0	1	0	0	0	
-38dB	0	0	1	1	1	
-40dB	0	0	1	1	0	
-42dB	0	0	1	0	1	
-44dB	0	0	1	0	0	
-46dB	0	0	0	1	1	
-48dB	0	0	0	1	0	
-50dB	0	0	0	0	1	
● -∞ dB	0	0	0	0	0	

SLOT14

FADER(REAR)

ATT	REAR Lch	D0	D1	D2	D3	D4
	REAR Rch	D5	D6	D7	D8	D9
0dB	1	1	0	1	0	
-2dB	1	1	0	0	1	
-4dB	1	1	0	0	0	
-6dB	1	0	1	1	1	
-8dB	1	0	1	1	0	
-10dB	1	0	1	0	1	
-12dB	1	0	1	0	0	
-14dB	1	0	0	1	1	
-16dB	1	0	0	1	0	
-18dB	1	0	0	0	1	
-20dB	1	0	0	0	0	
-22dB	0	1	1	1	1	
-24dB	0	1	1	1	0	
-26dB	0	1	1	0	1	
-28dB	0	1	1	0	0	
-30dB	0	1	0	1	1	
-32dB	0	1	0	1	0	
-34dB	0	1	0	0	1	
-36dB	0	1	0	0	0	
-38dB	0	0	1	1	1	
-40dB	0	0	1	1	0	
-42dB	0	0	1	0	1	
-44dB	0	0	1	0	0	
-46dB	0	0	0	1	1	
-48dB	0	0	0	1	0	
-50dB	0	0	0	0	1	
● -∞ dB	0	0	0	0	0	

● It's initial setting when VCC turn on.

SLOT15

soft-changing time

Time	D0	D1	D2
83mS(415mS)	1	1	1/0
66mS(33mS)	1	0	1/0
41mS(20.5mS)	0	1	1/0
33mS(<input checked="" type="radio"/> 16.5mS)	0	0	1/0

CLOCK select

CLOCK choice	D3
<input checked="" type="radio"/> External ceramic oscillator using	1
Internal oscillator using	0

Soft-changing ON / OFF

Soft-changing	D4
<input checked="" type="radio"/> ON	1
OFF	0

Soft-changing time can be changed with 1/0 of D2.
 •D2="1": The left time of the left table.
 (soft-changing time: 83mS,66mS,41mS,33mS)
 •D2="0": () time of the left table.
 (soft-changing time: 41.5mS,33mS,20.5mS,16.5mS)

Communication error countermeasure function

Countermeasure function	D5
<input checked="" type="radio"/> effective	1
ineffective	0

Soft-changing form

Form	D6
<input checked="" type="radio"/> Soft-changing 2	1
Soft-changing 1	0

Application Example

- At the time of use the internal oscillator (When D3= "0" of the slot 15.)

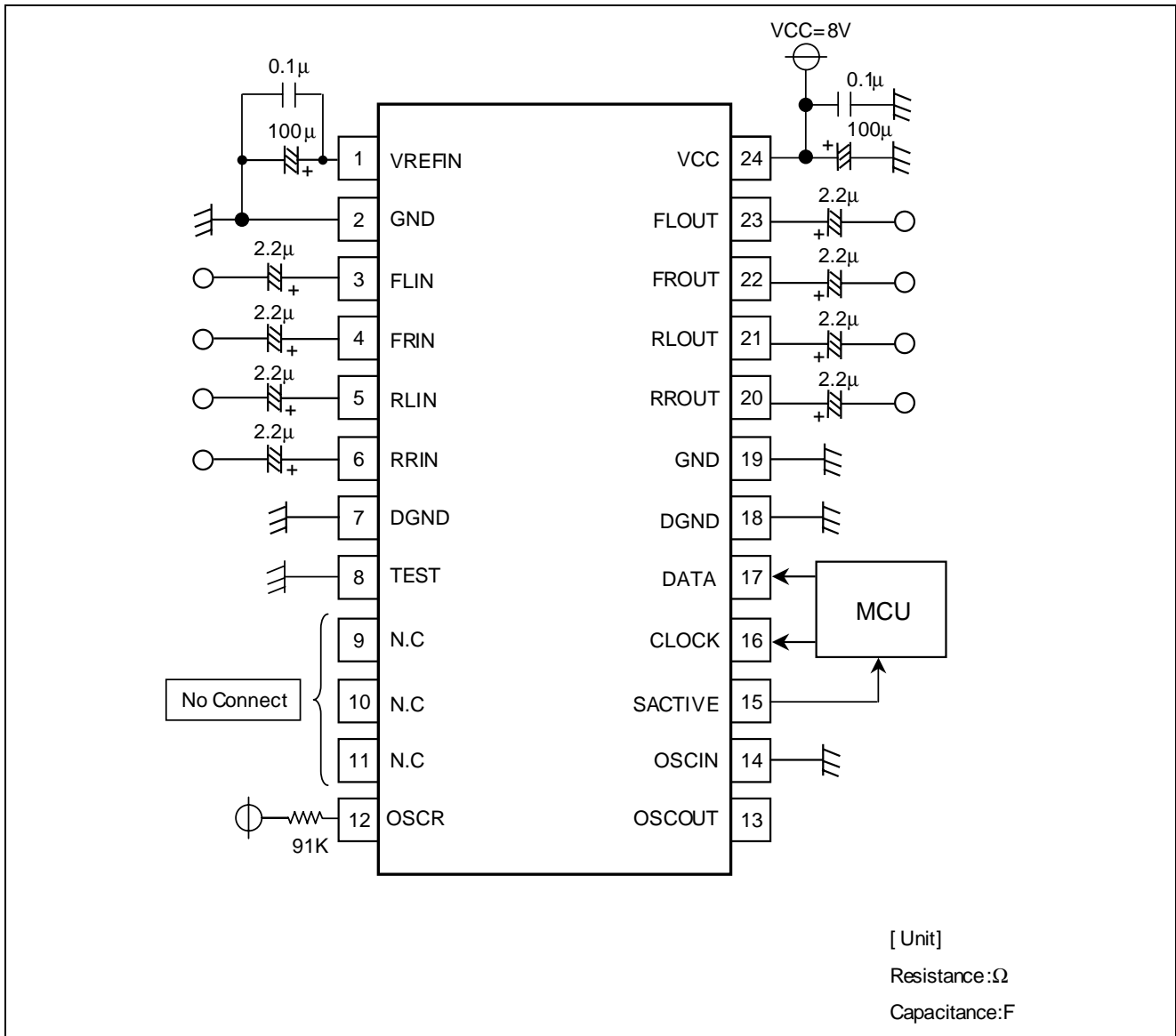

- At the time of use the external ceramic oscillator (fCLK=4.00MHz).
(When D3= "1" of the slot 15)

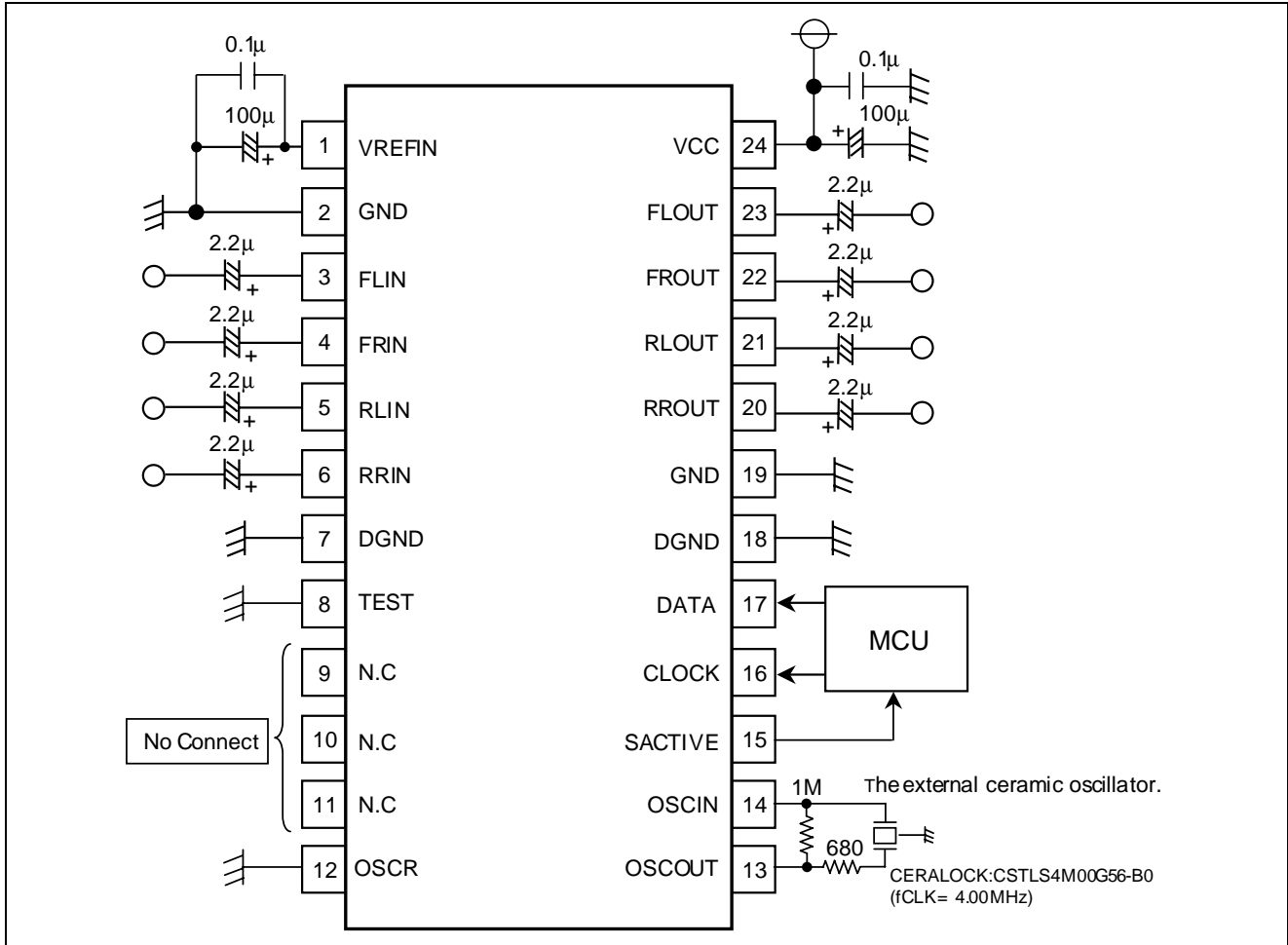

Package Dimensions

24P2Q-A

(MMP)

Plastic 24pin 300mil SSOP

EIAJ Package Code SSOP24-P-300-0.80	JEDEC Code —	Weight(g) 0.2	Lead Material Cu Alloy
--	-----------------	------------------	---------------------------

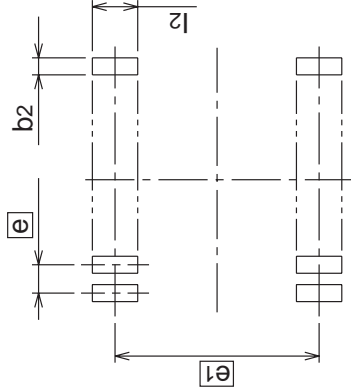
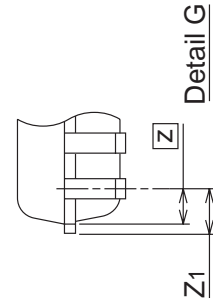
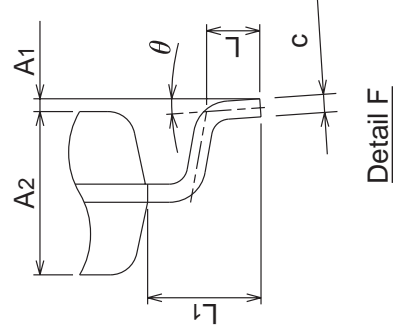
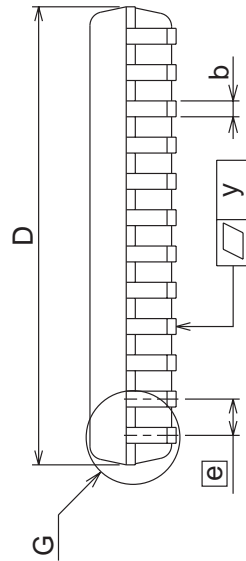
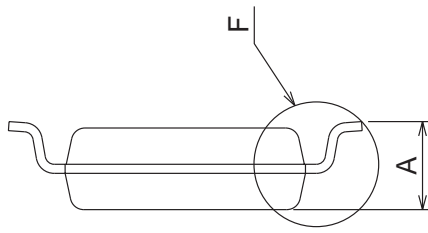
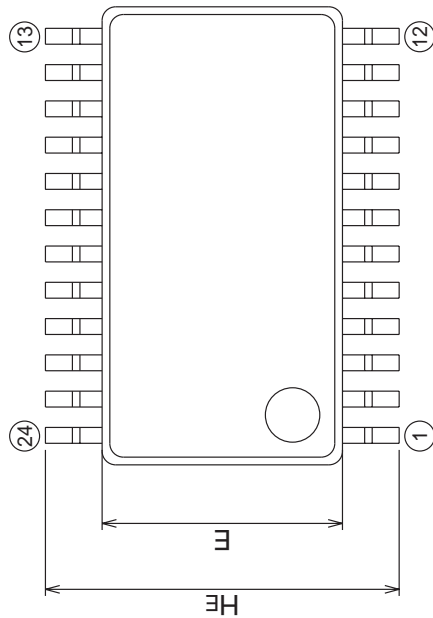

Recommended Mount Pad

Symbol	Dimension in Millimeters		
	Min	Norm	Max
A	—	—	2.1
A1	0	0.1	0.2
A2	—	1.8	—
b	0.3	0.35	0.45
c	0.18	0.2	0.25
D	10.0	10.1	10.2
E	5.2	5.3	5.4
e	—	0.8	—
HE	7.5	7.8	8.1
L	0.4	0.6	0.8
L1	—	1.25	—
Z	—	0.65	—
Z1	—	—	0.8
y	—	—	0.1
θ	0°	—	8°
b2	—	0.5	—
e1	—	7.62	—
l2	1.27	—	—

RENESAS Technology Corp. Sales Strategic Planning Div. Nippon Bldg., 2-6-2, Ohte-machi, Chiyoda-ku, Tokyo 100-0004, Japan

Keep safety first in your circuit designs!

1. Renesas Technology Corp. puts the maximum effort into making semiconductor products better and more reliable, but there is always the possibility that trouble may occur with them. Trouble with semiconductors may lead to personal injury, fire or property damage.
Remember to give due consideration to safety when making your circuit designs, with appropriate measures such as (i) placement of substitutive, auxiliary circuits, (ii) use of nonflammable material or (iii) prevention against any malfunction or mishap.

Notes regarding these materials

1. These materials are intended as a reference to assist our customers in the selection of the Renesas Technology Corp. product best suited to the customer's application; they do not convey any license under any intellectual property rights, or any other rights, belonging to Renesas Technology Corp. or a third party.
 2. Renesas Technology Corp. assumes no responsibility for any damage, or infringement of any third-party's rights, originating in the use of any product data, diagrams, charts, programs, algorithms, or circuit application examples contained in these materials.
 3. All information contained in these materials, including product data, diagrams, charts, programs and algorithms represents information on products at the time of publication of these materials, and are subject to change by Renesas Technology Corp. without notice due to product improvements or other reasons. It is therefore recommended that customers contact Renesas Technology Corp. or an authorized Renesas Technology Corp. product distributor for the latest product information before purchasing a product listed herein.
The information described here may contain technical inaccuracies or typographical errors.
Renesas Technology Corp. assumes no responsibility for any damage, liability, or other loss rising from these inaccuracies or errors.
Please also pay attention to information published by Renesas Technology Corp. by various means, including the Renesas Technology Corp. Semiconductor home page (<http://www.renesas.com>).
 4. When using any or all of the information contained in these materials, including product data, diagrams, charts, programs, and algorithms, please be sure to evaluate all information as a total system before making a final decision on the applicability of the information and products. Renesas Technology Corp. assumes no responsibility for any damage, liability or other loss resulting from the information contained herein.
 5. Renesas Technology Corp. semiconductors are not designed or manufactured for use in a device or system that is used under circumstances in which human life is potentially at stake. Please contact Renesas Technology Corp. or an authorized Renesas Technology Corp. product distributor when considering the use of a product contained herein for any specific purposes, such as apparatus or systems for transportation, vehicular, medical, aerospace, nuclear, or undersea repeater use.
 6. The prior written approval of Renesas Technology Corp. is necessary to reprint or reproduce in whole or in part these materials.
 7. If these products or technologies are subject to the Japanese export control restrictions, they must be exported under a license from the Japanese government and cannot be imported into a country other than the approved destination.
Any diversion or reexport contrary to the export control laws and regulations of Japan and/or the country of destination is prohibited.
 8. Please contact Renesas Technology Corp. for further details on these materials or the products contained therein.
-



RENESAS SALES OFFICES

<http://www.renesas.com>

Renesas Technology America, Inc.
450 Holger Way, San Jose, CA 95134-1368, U.S.A
Tel: <1> (408) 382-7500 Fax: <1> (408) 382-7501

Renesas Technology Europe Limited.
Dukes Meadow, Millboard Road, Bourne End, Buckinghamshire, SL8 5FH, United Kingdom
Tel: <44> (1628) 585 100, Fax: <44> (1628) 585 900

Renesas Technology Europe GmbH
Dornacher Str. 3, D-85622 Feldkirchen, Germany
Tel: <49> (89) 380 70 0, Fax: <49> (89) 929 30 11

Renesas Technology Hong Kong Ltd.
7/F., North Tower, World Finance Centre, Harbour City, Canton Road, Hong Kong
Tel: <852> 2265-6688, Fax: <852> 2375-6836

Renesas Technology Taiwan Co., Ltd.
FL 10, #99, Fu-Hsing N. Rd., Taipei, Taiwan
Tel: <886> (2) 2715-2888, Fax: <886> (2) 2713-2999

Renesas Technology (Shanghai) Co., Ltd.
26/F., Ruijin Building, No.205 Maoming Road (S), Shanghai 200020, China
Tel: <86> (21) 6472-1001, Fax: <86> (21) 6415-2952

Renesas Technology Singapore Pte. Ltd.
1, Harbour Front Avenue, #06-10, Keppel Bay Tower, Singapore 098632
Tel: <65> 6213-0200, Fax: <65> 6278-8001