

To all our customers

Regarding the change of names mentioned in the document, such as Hitachi Electric and Hitachi XX, to Renesas Technology Corp.

The semiconductor operations of Mitsubishi Electric and Hitachi were transferred to Renesas Technology Corporation on April 1st 2003. These operations include microcomputer, logic, analog and discrete devices, and memory chips other than DRAMs (flash memory, SRAMs etc.) Accordingly, although Hitachi, Hitachi, Ltd., Hitachi Semiconductors, and other Hitachi brand names are mentioned in the document, these names have in fact all been changed to Renesas Technology Corp. Thank you for your understanding. Except for our corporate trademark, logo and corporate statement, no changes whatsoever have been made to the contents of the document, and these changes do not constitute any alteration to the contents of the document itself.

Renesas Technology Home Page: <http://www.renesas.com>

DataSheet4U.com

Renesas Technology Corp. DataSheet4U.com
Customer Support Dept.
April 1, 2003

Cautions

Keep safety first in your circuit designs!

1. Renesas Technology Corporation puts the maximum effort into making semiconductor products better and more reliable, but there is always the possibility that trouble may occur with them. Trouble with semiconductors may lead to personal injury, fire or property damage.

Remember to give due consideration to safety when making your circuit designs, with appropriate measures such as (i) placement of substitutive, auxiliary circuits, (ii) use of nonflammable material or (iii) prevention against any malfunction or mishap.

Notes regarding these materials

1. These materials are intended as a reference to assist our customers in the selection of the Renesas Technology Corporation product best suited to the customer's application; they do not convey any license under any intellectual property rights, or any other rights, belonging to Renesas Technology Corporation or a third party.
2. Renesas Technology Corporation assumes no responsibility for any damage, or infringement of any third-party's rights, originating in the use of any product data, diagrams, charts, programs, algorithms, or circuit application examples contained in these materials.
3. All information contained in these materials, including product data, diagrams, charts, programs and algorithms represents information on products at the time of publication of these materials, and are subject to change by Renesas Technology Corporation without notice due to product improvements or other reasons. It is therefore recommended that customers contact Renesas Technology Corporation or an authorized Renesas Technology Corporation product distributor for the latest product information before purchasing a product listed herein.

The information described here may contain technical inaccuracies or typographical errors.

Renesas Technology Corporation assumes no responsibility for any damage, liability, or other loss rising from these inaccuracies or errors.

Please also pay attention to information published by Renesas Technology Corporation by various means, including the Renesas Technology Corporation Semiconductor home page (<http://www.renesas.com>).

4. When using any or all of the information contained in these materials, including product data, diagrams, charts, programs, and algorithms, please be sure to evaluate all information as a total system before making a final decision on the applicability of the information and products. Renesas Technology Corporation assumes no responsibility for any damage, liability or other loss resulting from the information contained herein.
5. Renesas Technology Corporation semiconductors are not designed or manufactured for use in a device or system that is used under circumstances in which human life is potentially at stake. Please contact Renesas Technology Corporation or an authorized Renesas Technology Corporation product distributor when considering the use of a product contained herein for any specific purposes, such as apparatus or systems for transportation, vehicular, medical, aerospace, nuclear, or undersea repeater use.
6. The prior written approval of Renesas Technology Corporation is necessary to reprint or reproduce in whole or in part these materials.
7. If these products or technologies are subject to the Japanese export control restrictions, they must be exported under a license from the Japanese government and cannot be imported into a country other than the approved destination.

Any diversion or reexport contrary to the export control laws and regulations of Japan and/or the country of destination is prohibited.

8. Please contact Renesas Technology Corporation for further details on these materials or the products contained therein.

The revision list can be viewed directly by clicking the title page.

The revision list summarizes the locations of revisions and additions. Details should always be checked by referring to the relevant text.

SH7604

Hardware Manual

The logo for Renesas, featuring a stylized 'R' followed by the word 'RENESAS' in a bold, sans-serif font.

DataSheet4U.com

ADE-602-085C
Rev. 4.0
3/5/03
Hitachi, Ltd.

Cautions

1. Hitachi neither warrants nor grants licenses of any rights of Hitachi's or any third party's patent, copyright, trademark, or other intellectual property rights for information contained in this document. Hitachi bears no responsibility for problems that may arise with third party's rights, including intellectual property rights, in connection with use of the information contained in this document.
2. Products and product specifications may be subject to change without notice. Confirm that you have received the latest product standards or specifications before final design, purchase or use.
3. Hitachi makes every attempt to ensure that its products are of high quality and reliability. However, contact Hitachi's sales office before using the product in an application that demands especially high quality and reliability or where its failure or malfunction may directly threaten human life or cause risk of bodily injury, such as aerospace, aeronautics, nuclear power, combustion control, transportation, traffic, safety equipment or medical equipment for life support.
4. Design your application so that the product is used within the ranges guaranteed by Hitachi particularly for maximum rating, operating supply voltage range, heat radiation characteristics, installation conditions and other characteristics. Hitachi bears no responsibility for failure or damage when used beyond the guaranteed ranges. Even within the guaranteed ranges, consider normally foreseeable failure rates or failure modes in semiconductor devices and employ systemic measures such as fail-safes, so that the equipment incorporating Hitachi product does not cause bodily injury, fire or other consequential damage due to operation of the Hitachi product.
5. This product is not designed to be radiation resistant.
6. No one is permitted to reproduce or duplicate, in any form, the whole or part of this document without written approval from Hitachi.
7. Contact Hitachi's sales office for any questions regarding this document or Hitachi semiconductor products.

Preface

The SH7604 implements high-performance operations by using a CPU which employs the Reduced Instruction Set Computer (RISC) system. The SH7604 is a new-generation RISC microcomputer which realizes low power consumption, an essential feature of microcomputer devices, as well as integrating peripheral features necessary for system configuration.

The CPU of the SH7604 has a set of RISC-type instructions; basic instructions operate at one state per instruction, that is, in one system clock cycle, dramatically increasing execution speeds. The SH7604 incorporates a 32-bit multiplier which performs high-speed sum-of-product (multiply-and-accumulate) operations. Instructions used by the SH7604 are upwardly compatible with the SH7000 Series, allowing easy migration from the SH7000 Series to the SH7604.

Moreover, the SH7604 incorporates on-chip peripheral modules such as an interrupt controller (INTC), direct memory access controller (DMAC), division unit (DIVU), timers (FRT, WDT), and serial communication interface (SCI), so that a user system can be configured using the minimum number of parts.

On-chip cache memory enhances the CPU throughput. A bus control feature, which supports external memory access, improves external memory access efficiency, allowing direct connection to synchronous DRAM, DRAM, and pseudo-SRAM without the help of glue logic.

This hardware manual explains the hardware features of the SH7604. For details of instructions, see the Programming Manual.

Related Documents

SH7604 instructions

“SH-1/SH-2 Programming Manual” (Document No.: ADE-602-063B)

For the development environment system, call your nearest Hitachi sales office.

DataSheet4U.com

et4U.com

DataShee

DataSheet4U.com

www.DataSheet4U.com

DataSheet4U.com

List of Items Revised or Added for This Version

Section	Page	Item	Description (see Manual for details)
1.1.1 Features of the SH7604	2	Operation Modes	Description of Clock mode added
	4	Package	176-pin plastic TFBGA (TBP-176) added
1.3.1 Pin Arrangement	5	Product Lineup	Added
	8	Figure 1.3 Pin Arrangement (176-Pin Plastic TFBGA)	Added
1.3.2 Pin Functions	9	Table 1.1 Pin Functions	Pin No. (TBP-176) added
3.2.2 Clock Operating Mode Setting	51		Description added
	52	Table 3.3 Clock Mode Pin Settings and States	Note 3 added
3.2.7 Notes on Board Design	61	When Using PLL Oscillation Circuits	Description replaced
	62	Figure 3.9 Design Consideration When Using PLL Oscillation Circuits	Figure amended, additional description of figure
Appendix C External Dimensions	616	Figure C.2 External Dimensions (TBP-176)	Added

DataSheet4U.com

et4U.com

DataShee

DataSheet4U.com

www.DataSheet4U.com

DataSheet4U.com

Contents

Section 1	Overview and Pin Functions	1
1.1	SH7604 Features.....	1
1.1.1	Features of the SH7604.....	1
1.2	Block Diagram.....	6
1.3	Description of Pins.....	7
1.3.1	Pin Arrangement.....	7
1.3.2	Pin Functions.....	9
Section 2	CPU	15
2.1	Register Configuration.....	15
2.1.1	General Registers.....	15
2.1.2	Control Registers.....	16
2.1.3	System Registers.....	17
2.1.4	Initial Values of Registers.....	17
2.2	Data Formats.....	18
2.2.1	Data Format in Registers.....	18
2.2.2	Data Format in Memory.....	18
2.2.3	Immediate Data Format.....	19
2.3	Instruction Features.....	19
2.3.1	RISC-Type Instruction Set.....	19
2.3.2	Addressing Modes.....	22
2.3.3	Instruction Formats.....	25
2.4	Instruction Set.....	29
2.4.1	Instruction Set by Classification.....	29
2.4.2	Operation Code Map.....	42
2.5	Processing States.....	44
2.5.1	State Transitions.....	44
2.5.2	Power-Down State.....	46
Section 3	Oscillator Circuits and Operating Modes	49
3.1	Overview.....	49
3.2	On-Chip Clock Pulse Generator and Operating Modes.....	49
3.2.1	Clock Pulse Generator.....	49
3.2.2	Clock Operating Mode Settings.....	51
3.2.3	Connecting a Crystal Resonator.....	52
3.2.4	Inputting an External Clock.....	54
3.2.5	Selecting Operating Frequency with a Register.....	54
3.2.6	Operating Modes and Frequency Ranges.....	60
3.2.7	Notes on Board Design.....	60

3.3	Bus Width of the CS0 Area	62
3.4	Switching between Master Mode and Slave Mode	63
Section 4	Exception Handling.....	65
4.1	Overview.....	65
4.1.1	Types of Exception Handling and Priority Order	65
4.1.2	Exception Handling Operations	66
4.1.3	Exception Vector Table.....	67
4.2	Resets	69
4.2.1	Types of Resets	69
4.2.2	Power-On Reset.....	70
4.2.3	Manual Reset.....	70
4.3	Address Errors	71
4.3.1	Sources of Address Errors.....	71
4.3.2	Address Error Exception Handling	72
4.4	Interrupts.....	72
4.4.1	Interrupt Sources	72
4.4.2	Interrupt Priority Levels	73
4.4.3	Interrupt Exception Handling	73
4.5	Exceptions Triggered by Instructions.....	74
4.5.1	Instruction-Triggered Exception Types.....	74
4.5.2	Trap Instructions	74
4.5.3	Illegal Slot Instructions	74
4.5.4	General Illegal Instructions	75
4.6	When Exception Sources are Not Accepted.....	75
4.6.1	Immediately after a Delayed Branch Instruction.....	75
4.6.2	Immediately after an Interrupt-Disabled Instruction.....	76
4.7	Stack Status after Exception Handling	76
4.8	Usage Notes	76
4.8.1	Value of Stack Pointer (SP).....	76
4.8.2	Value of Vector Base Register (VBR)	76
4.8.3	Address Errors Caused by Stacking of Address Error Exception Handling	77
4.8.4	Manual Reset during Register Access.....	77
Section 5	Interrupt Controller (INTC).....	79
5.1	Overview.....	79
5.1.1	Features	79
5.1.2	Block Diagram.....	79
5.1.3	Pin Configuration	81
5.1.4	Register Configuration	81
5.2	Interrupt Sources.....	82
5.2.1	NMI Interrupt	82
5.2.2	User Break Interrupt	82

5.2.3	IRL Interrupts	83
5.2.4	On-chip Peripheral Module Interrupts.....	85
5.2.5	Interrupt Exception Vectors and Priority Order	86
5.3	Description of Registers	88
5.3.1	Interrupt Priority Level Setting Register A (IPRA)	88
5.3.2	Interrupt Priority Level Setting Register B (IPRB).....	89
5.3.3	Vector Number Setting Register WDT (VCRWDT)	91
5.3.4	Vector Number Setting Register A (VCRA).....	91
5.3.5	Vector Number Setting Register B (VCRB)	92
5.3.6	Vector Number Setting Register C (VCRC)	93
5.3.7	Vector Number Setting Register D (VCRD).....	94
5.3.8	Interrupt Control Register (ICR).....	95
5.4	Interrupt Operation	97
5.4.1	Interrupt Sequence.....	97
5.4.2	Stack after Interrupt Exception Handling	99
5.5	Interrupt Response Time.....	100
5.6	Sampling of Pins $\overline{IRL3}$ – $\overline{IRL0}$	101
5.7	Usage Notes	103
Section 6 User Break Controller		107
6.1	Overview.....	107
6.1.1	Features	107
6.1.2	Block Diagram.....	108
6.1.3	Register Configuration	109
6.2	Register Descriptions.....	110
6.2.1	Break Address Register A (BARA)	110
6.2.2	Break Address Mask Register A (BAMRA).....	111
6.2.3	Break Bus Cycle Register A (BBRA)	112
6.2.4	Break Address Register B (BARB).....	114
6.2.5	Break Address Mask Register B (BAMRB)	114
6.2.6	Break Data Register B (BDRB)	114
6.2.7	Break Data Mask Register B (BDMRB).....	115
6.2.8	Bus Break Register B (BBRB).....	116
6.2.9	Break Control Register (BRCR)	116
6.3	Operation	120
6.3.1	Flow of the User Break Operation.....	120
6.3.2	Break on Instruction Fetch Cycle.....	120
6.3.3	Break on Data Access Cycle	121
6.3.4	Break on External Bus Cycle	122
6.3.5	Program Counter (PC) Values Saved	122
6.3.6	Example of Use	123
6.3.7	Usage Notes.....	126
6.3.8	SH7000 Series Compatible Mode.....	127

Section 7	Bus State Controller (BSC)	129
7.1	Overview	129
7.1.1	Features	129
7.1.2	Block Diagram	130
7.1.3	Pin Configuration	132
7.1.4	Register Configuration	134
7.1.5	Address Map	134
7.2	Description of Registers	136
7.2.1	Bus Control Register 1 (BCR1)	136
7.2.2	Bus Control Register 2 (BCR2)	138
7.2.3	Wait Control Register (WCR)	140
7.2.4	Individual Memory Control Register (MCR)	142
7.2.5	Refresh Timer Control/Status Register (RTCSR)	146
7.2.6	Refresh Timer Counter (RTCNT)	147
7.2.7	Refresh Time Constant Register (RTCOR)	148
7.3	Access Size and Data Alignment	148
7.3.1	Connection to Ordinary Devices	148
7.3.2	Connection to Little-Endian Devices	150
7.4	Accessing Ordinary Space	151
7.4.1	Basic Timing	151
7.4.2	Wait State Control	155
7.5	Synchronous DRAM Interface	157
7.5.1	Synchronous DRAM Direct Connection	157
7.5.2	Address Multiplexing	159
7.5.3	Burst Reads	160
7.5.4	Single Reads	164
7.5.5	Writes	165
7.5.6	Bank Active Function	166
7.5.7	Refreshes	174
7.5.8	Power-On Sequence	177
7.5.9	Phase Shift by PLL	179
7.6	DRAM Interface	181
7.6.1	DRAM Direct Connection	181
7.6.2	Address Multiplexing	183
7.6.3	Basic Timing	184
7.6.4	Wait State Control	185
7.6.5	Burst Access	186
7.6.6	Refresh Timing	188
7.6.7	Power-On Sequence	189
7.7	Pseudo-SRAM Interface	189
7.7.1	Pseudo-SRAM Direct Connection	189
7.7.2	Basic Timing	192
7.7.3	Wait State Control	193

7.7.4	Burst Access	194
7.7.5	Refreshing	195
7.7.6	Power-On Sequence	197
7.8	Burst ROM Interface	197
7.9	Waits between Access Cycles	200
7.10	Bus Arbitration	201
7.10.1	Master Mode	203
7.10.2	Slave Mode	205
7.10.3	Partial-Share Master Mode	206
7.10.4	External Bus Address Monitor	209
7.10.5	Master/Slave Coordination	209
7.11	Other Topics	210
7.11.1	Resets	210
7.11.2	Access as Seen from the CPU or DMAC	210
7.11.3	Emulator	212
Section 8	Cache	213
8.1	Introduction	213
8.2	Cache Control Register (CCR)	214
8.3	Address Space and the Cache	216
8.4	Cache Operation	216
8.4.1	Cache Reads	216
8.4.2	Write Access	219
8.4.3	Cache-Through Access	220
8.4.4	The TAS Instruction	221
8.4.5	Pseudo-LRU and Cache Replacement	222
8.4.6	Cache Initialization	224
8.4.7	Associative Purges	224
8.4.8	Data Array Access	224
8.4.9	Address Array Access	225
8.5	Cache Use	226
8.5.1	Initialization	226
8.5.2	Purge of Specific Lines	227
8.5.3	Cache Data Coherency	227
8.5.4	Two-Way Cache Mode	228
8.5.5	Usage Notes	229
Section 9	Direct Memory Access Controller (DMAC)	231
9.1	Overview	231
9.1.1	Features	231
9.1.2	Block Diagram	233
9.1.3	Pin Configuration	234
9.1.4	Register Configuration	234

9.2	Register Descriptions.....	235
9.2.1	DMA Source Address Registers 0 and 1 (SAR0 and SAR1).....	235
9.2.2	DMA Destination Address Registers 0 and 1 (DAR0 and DAR1).....	236
9.2.3	DMA Transfer Count Registers 0 and 1 (TCR0 and TCR1).....	236
9.2.4	DMA Channel Control Registers 0 and 1 (CHCR0 and CHCR1).....	237
9.2.5	DMA Vector Number Registers 0 and 1 (VCRDMA0, VCRDMA1).....	241
9.2.6	DMA Request/Response Selection Control Registers 0 and 1 (DRCR0, DRCR1).....	242
9.2.7	DMA Operation Register (DMAOR).....	243
9.3	Operation.....	245
9.3.1	DMA Transfer Flow.....	245
9.3.2	DMA Transfer Requests.....	247
9.3.3	Channel Priorities.....	249
9.3.4	DMA Transfer Types.....	251
9.3.5	Number of Bus Cycles.....	258
9.3.6	DMA Transfer Request Acknowledge Signal Output Timing.....	258
9.3.7	DREQ Pin Input Detection Timing.....	268
9.3.8	DMA Transfer End.....	283
9.4	Examples of Use.....	284
9.4.1	DMA Transfer Between On-Chip SCI and External Memory.....	284
9.5	Usage Notes.....	285

Section 10 Division Unit..... [DataSheet4U.com](http://www.DataSheet4U.com)..... 287

10.1	Overview.....	287
10.1.1	Features.....	287
10.1.2	Block Diagram.....	288
10.1.3	Register Configuration.....	288
10.2	Description of Registers.....	289
10.2.1	Divisor Register (DVSR).....	289
10.2.2	Dividend Register L for 32-Bit Division (DVDNT).....	289
10.2.3	Division Control Register (DVCR).....	290
10.2.4	Vector Number Setting Register DIV (VCRDIV).....	291
10.2.5	Dividend Register H (DVDNTH).....	291
10.2.6	Dividend Register L (DVDNTL).....	292
10.3	Operation.....	292
10.3.1	64-Bit ÷ 32-Bit Operations.....	292
10.3.2	32-Bit ÷ 32-Bit Operations.....	292
10.3.3	Handling of Overflows.....	293
10.4	Usage Notes.....	293
10.4.1	Access.....	293
10.4.2	Overflow Flag.....	294

Section 11	16-Bit Free-Running Timer	295
11.1	Overview.....	295
11.1.1	Features	295
11.1.2	Block Diagram.....	296
11.1.3	Pin Configuration	297
11.1.4	Register Configuration	297
11.2	Register Descriptions.....	298
11.2.1	Free-Running Counter (FRC).....	298
11.2.2	Output Compare Registers A and B (OCRA and OCRB).....	298
11.2.3	Input Capture Register (ICR)	299
11.2.4	Timer Interrupt Enable Register (TIER)	299
11.2.5	Free-Running Timer Control/Status Register (FTCSR).....	300
11.2.6	Timer Control Register (TCR)	302
11.2.7	Timer Output Compare Control Register (TOCR)	303
11.3	CPU Interface	304
11.4	Operation	307
11.4.1	FRC Count Timing	307
11.4.2	Output Timing for Output Compare.....	308
11.4.3	FRC Clear Timing	308
11.4.4	Input Capture Input Timing.....	309
11.4.5	Input Capture Flag (ICF) Setting Timing	310
11.4.6	Output Compare Flag (OCFA, OCFB) Setting Timing	310
11.4.7	Timer Overflow Flag (OVF) Setting Timing	311
11.5	Interrupt Sources.....	312
11.6	Example of FRT Use	312
11.7	Usage Notes	313

Section 12	Watchdog Timer (WDT)	319
12.1	Overview.....	319
12.1.1	Features	319
12.1.2	Block Diagram.....	320
12.1.3	Pin Configuration	320
12.1.4	Register Configuration	321
12.2	Register Descriptions.....	321
12.2.1	Watchdog Timer Counter (WTCNT).....	321
12.2.2	Watchdog Timer Control/Status Register (WTCSR).....	322
12.2.3	Reset Control/Status Register (RSTCSR).....	323
12.2.4	Register Access	324
12.3	Operation	326
12.3.1	Operation in Watchdog Timer Mode	326
12.3.2	Operation in Interval Timer Mode	328
12.3.3	Operation in Standby Mode.....	328
12.3.4	Timing of Overflow Flag (OVF) Setting.....	329

12.3.5	Timing of Watchdog Timer Overflow Flag (WOVF) Setting.....	329
12.4	Usage Notes	330
12.4.1	Contention between WTCNT Write and Increment	330
12.4.2	Changing CKS2 to CKS0 Bit Values	330
12.4.3	Switching between Watchdog Timer and Interval Timer Mode.....	330
12.4.4	System Reset with <u>WDTOVF</u>	331
12.4.5	Internal Reset in Watchdog Timer Mode	331

Section 13 Serial Communication Interface 333

13.1	Overview.....	333
13.1.1	Features	333
13.1.2	Block Diagram.....	334
13.1.3	Pin Configuration	334
13.1.4	Register Configuration	335
13.2	Register Descriptions.....	335
13.2.1	Receive Shift Register (RSR).....	335
13.2.2	Receive Data Register (RDR).....	335
13.2.3	Transmit Shift Register (TSR).....	336
13.2.4	Transmit Data Register (TDR).....	336
13.2.5	Serial Mode Register (SMR).....	336
13.2.6	Serial Control Register (SCR).....	339
13.2.7	Serial Status Register (SSR).....	342
13.2.8	Bit Rate Register (BRR).....	346
13.3	Operation	352
13.3.1	Overview	352
13.3.2	Operation in Asynchronous Mode.....	354
13.3.3	Multiprocessor Communication	364
13.3.4	Clocked Synchronous Operation.....	371
13.4	SCI Interrupt Sources and the DMAC.....	381
13.5	Usage Notes	381

Section 14 Power-Down Modes 385

14.1	Overview.....	385
14.1.1	Power-Down Modes	385
14.1.2	Register.....	386
14.2	Description of Register.....	387
14.2.1	Standby Control Register (SBYCR)	387
14.3	Sleep Mode.....	389
14.3.1	Transition to Sleep Mode	389
14.3.2	Canceling Sleep Mode.....	389
14.4	Standby Mode.....	389
14.4.1	Transition to Standby Mode	389
14.4.2	Canceling Standby Mode	390

14.4.3	Standby Mode Cancellation by NMI.....	391
14.4.4	Clock Pause Function.....	391
14.4.5	Notes on Standby Mode.....	393
14.5	Module Standby Function.....	393
14.5.1	Transition to Module Standby Function.....	393
14.5.2	Clearing the Module Standby Function.....	393
Section 15 Electrical Characteristics (5V Version).....		395
15.1	Absolute Maximum Ratings.....	395
15.2	DC Characteristics.....	396
15.3	AC Characteristics.....	398
15.3.1	Clock Timing.....	398
15.3.2	Control Signal Timing.....	402
15.3.3	Bus Timing.....	408
15.3.4	DMAC Timing.....	474
15.3.5	Free-Running Timer Timing.....	475
15.3.6	Watchdog Timer Timing.....	476
15.3.7	Serial Communication Interface Timing.....	477
15.3.8	AC Characteristics Measurement Conditions.....	478
Section 16 Electrical Characteristics (3V Version).....		479
16.1	Absolute Maximum Ratings.....	479
16.2	DC Characteristics.....	480
16.3	AC Characteristics.....	482
16.3.1	Clock Timing.....	482
16.3.2	Control Signal Timing.....	486
16.3.3	Bus Timing.....	492
16.3.4	DMAC Timing.....	558
16.3.5	Free-Running Timer Timing.....	559
16.3.6	Watchdog Timer Timing.....	560
16.3.7	Serial Communication Interface Timing.....	561
16.3.8	AC Characteristics Measurement Conditions.....	562
Appendix A Pin States.....		563
Appendix B List of Registers.....		565
Appendix C External Dimensions.....		615

DataSheet4U.com

et4U.com

DataShee

DataSheet4U.com

www.DataSheet4U.com

Section 1 Overview and Pin Functions

1.1 SH7604 Features

The SH7604 is a new-generation single-chip RISC microprocessor that integrates a Hitachi-original CPU, a multiplier, cache memory, and peripheral functions required for system configuration.

The CPU features a RISC-type instruction set. Most instructions can be executed in one clock cycle, which greatly improves instruction execution speed. In addition, the on-chip 4-kbyte cache memory and divider enhance data processing ability.

The SH7604 is also provided with on-chip peripheral functions including a direct memory access controller (DMAC), timers, a serial communication interface (SCI), and an interrupt controller. External memory access support functions (provided by the bus state controller) enable direct connection to DRAM, synchronous DRAM, and pseudo-SRAM.

The high-speed CPU and comprehensive peripheral functions enable designers to construct high-performance systems with advanced functionality at low cost, even in applications such as real-time control that require very high speeds, impossible with conventional microprocessors.

1.1.1 Features of the SH7604

DataSheet4U.com

CPU:

- Original Hitachi architecture
- 32-bit internal configuration
- General-registers:
 - Sixteen 32-bit general registers
 - Three 32-bit control registers
 - Four 32-bit system registers
- RISC-type instruction set:
 - Instruction length: 16-bit fixed length for improved code efficiency
 - Load-store architecture (basic arithmetic and logic operations are executed between registers)
 - Delayed conditional/unconditional branch instructions reduce pipeline disruption during branching
 - Instruction set based on C language
- Instruction execution time: one instruction/state (35 ns/instruction at 28.7 MHz operation)
- Address space: 4 Gbytes available in the architecture (128-Mbyte memory space)

- On-chip multiplier: multiply operations ($32 \text{ bits} \times 32 \text{ bits} \rightarrow 64 \text{ bits}$) and multiply-and-accumulate operations ($32 \text{ bits} \times 32 \text{ bits} + 64 \text{ bits} \rightarrow 64 \text{ bits}$) executed in 2 to 4 states
- Five-stage pipeline

Operating Modes:

- Clock mode: selected from the combination of an on-chip oscillator module, a frequency multiplier, clock output, PLL synchronization, and 90° phase shifting (the range of choices depends on the package)
- Slave/master mode
- Processing states
 - Power-on reset state
 - Manual reset state
 - Exception handling state
 - Program execution state
 - Power-down state
 - Bus-released state
- Power-down states
 - Sleep mode
 - Standby mode
 - Module stop mode

DataSheet4U.com

Interrupt Controller (INTC):

- Five external interrupt pins ($\overline{\text{NMI}}$, $\overline{\text{IRL0}}$ to $\overline{\text{IRL3}}$), encoded input of 15 external interrupt sources via pins $\overline{\text{IRL0}}$ to $\overline{\text{IRL3}}$
- Twelve internal interrupt sources ($\text{DMAC} \times 2$, $\text{DIVU} \times 1$, $\text{FRT} \times 3$, $\text{WDT} \times 1$, $\text{SCI} \times 4$, $\text{REF} \times 1$)
- Sixteen programmable priority levels
- Vector number settable for each internal interrupt source
- Auto-vector or external vector selectable as vector for external interrupts via pins $\overline{\text{IRL0}}$ to $\overline{\text{IRL3}}$

User Break Controller (UBC):

- Generates an interrupt when the CPU or DMAC generates an address, data, or bus cycle with the specified conditions (address, data, CPU cycle/non-CUP cycle, instruction fetch/data access, read/write, byte/word/longword access)
- Simplifies configuration of a self-debugger

DataSheet4U.com

www.DataSheet4U.com

Clock Pulse Generator (CPG)/Phase Locked Loop (PLL):

- On-chip clock pulse generator
- Crystal clock source or external clock source can be selected
- Clock multiplication ($\times 1$, $\times 2$, $\times 4$), PLL synchronization, or 90° phase shift can be selected
- Supports clock pause function for frequency change of external clock

Bus State Controller (BSC):

- Supports external memory access
 - 32-bit external data bus
- Memory address space divided into four areas. It is possible to set the following characteristics for each area (32 Mbyte linear):
 - Bus size (8, 16, or 32 bits)
 - Number of wait cycles settable or not settable
 - Setting the memory space type simplifies connection to DRAM, synchronous DRAM, pseudo-SRAM, and burst ROM
 - Outputs signals $\overline{\text{RAS}}$, $\overline{\text{CAS}}$, $\overline{\text{CE}}$, and $\overline{\text{OE}}$ corresponding to DRAM, synchronous DRAM, and pseudo-SRAM areas
 - T_p cycles can be generated to assure RAS precharge time
 - Address multiplexing is supported internally, so DRAM and synchronous DRAM can be connected directly
 - Outputs chip select signals ($\overline{\text{CS0}}$ to $\overline{\text{CS3}}$) for each area
- DRAM/synchronous DRAM/pseudo-SRAM refresh functions
 - Programmable refresh interval
 - Supports CAS-before-RAS refresh and self-refresh modes
- DRAM/synchronous DRAM/pseudo-SRAM burst access function
 - Supports high-speed access modes for DRAM/synchronous DRAM/pseudo-SRAM
- Wait cycles can be inserted by an external WAIT signal

Cache Memory:

- 4 kbytes
- 64 entries, 4-way set associative, 16-byte line length
- Write-through data writing method
- LRU replacement algorithm
- 2 kbytes of the cache can be used as 2-kbyte internal RAM

Direct Memory Access Controller (DMAC) (2 Channels):

- Permits DMA transfer between external memory, external I/O, on-chip peripheral modules
- Enables DMA transfer request and auto-request from external pins, on-chip SCI, and on-chip timers
- Cycle-steal mode or burst mode
- Channel priority level is selectable (fixed mode or round-robin mode)
- Dual or single address transfer mode is selectable
- Transfer data width: 1/2/4/16 bytes
- Address space: 4 Gbytes; maximum number of transfers: 16,777,216

Division Unit (DIVU):

- Executes $64 \div 32 \rightarrow 32 \dots 32$ and $32 \div 32 \rightarrow 32 \dots 32$ divisions in 39 cycles
- Overflow interrupt

16-Bit Free-Running Timer (FRT) (1 Channel):

- Selects input from three internal/external clocks
- Input capture and output compare
- Counter overflow, compare match, and input capture interrupts

Watchdog Timer (WDT) (1 Channel):

- Can be switched between watchdog timer and interval timer functions
- Count overflow can generate an internal reset, external signal, or interrupt
- Power-on reset or manual reset can be selected as the internal reset

Serial Communication Interface (SCI) (1 Channel):

- Asynchronous or synchronous mode is selectable
- Simultaneous transmission and reception (full duplex)
- Dedicated baud rate generator
- Multiprocessor communication function

Package:

- 144-pin plastic QFP (FP-144J)
- 176-pin plastic TFBGA (TBP-176)

Product Lineup:

Product Code	Package	Operating Temperature	Frequency	Voltage
HD6417604SF28	QFP2020-144	- 20°C to 75°C	28 MHz	5 V
HD6417604SFI28	QFP2020-144	- 40°C to 85°C	28 MHz	5 V
HD6417604SVF20	QFP2020-144	- 20°C to 75°C	20 MHz	3.3 V
HD6417604SBP28	CSP-1313-176	- 20°C to 75°C	28 MHz	5 V
HD6417604SVBP20	CSP-1313-176	- 20°C to 75°C	20 MHz	3.3 V

DataSheet4U.com

et4U.com

DataShee

DataSheet4U.com

www.DataSheet4U.com

DataSheet4U.com

1.2 Block Diagram

Figure 1.1 shows a block diagram of the SH7604.

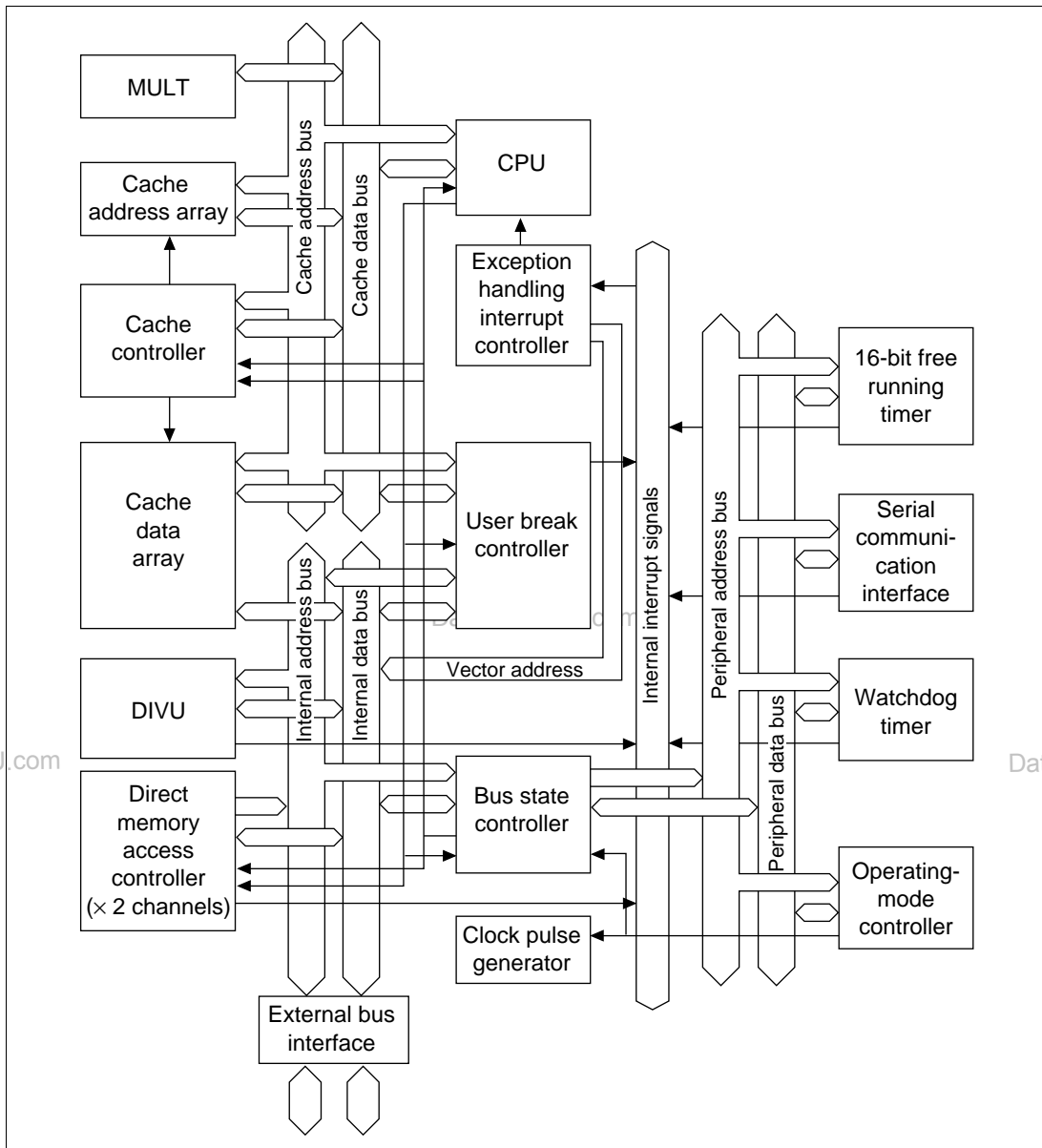

Figure 1.1 Block Diagram

1.3 Description of Pins

1.3.1 Pin Arrangement

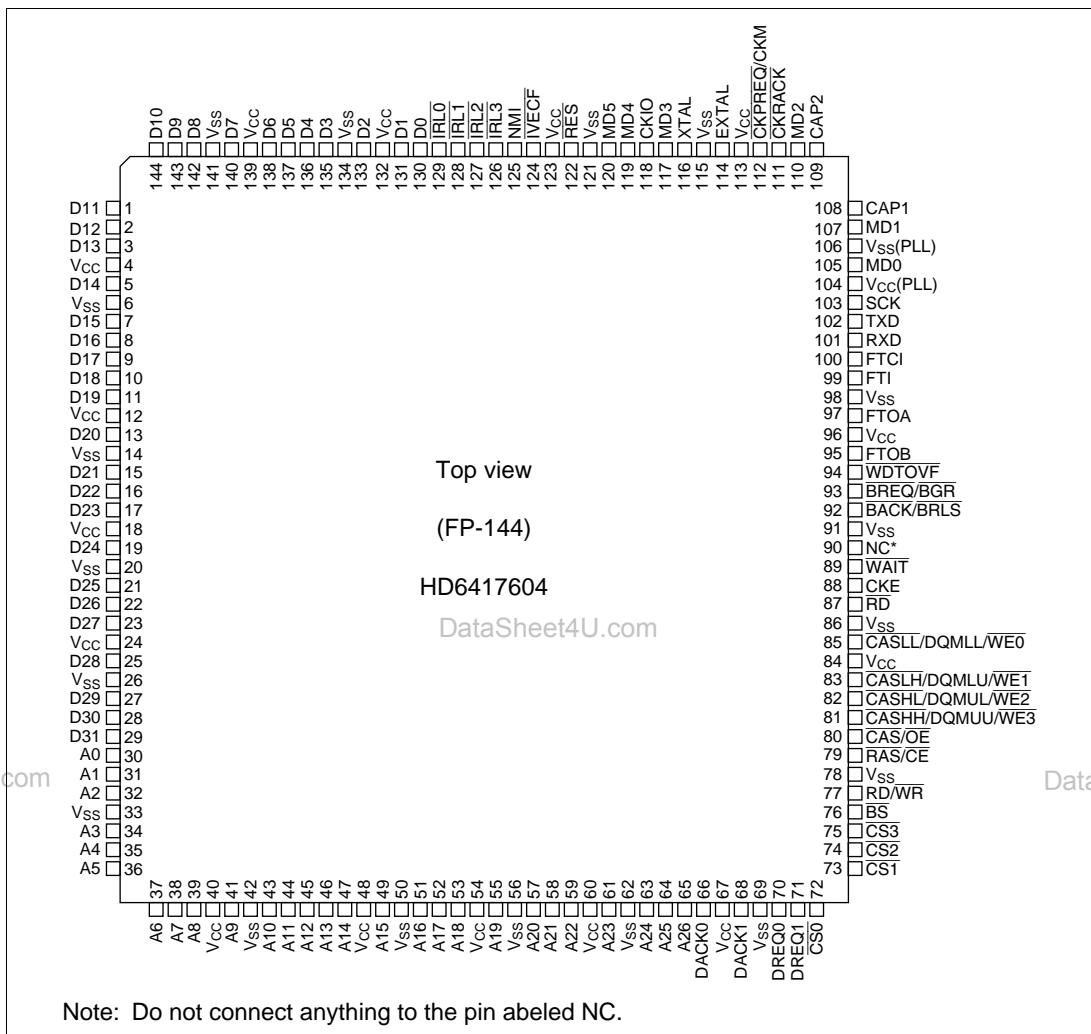
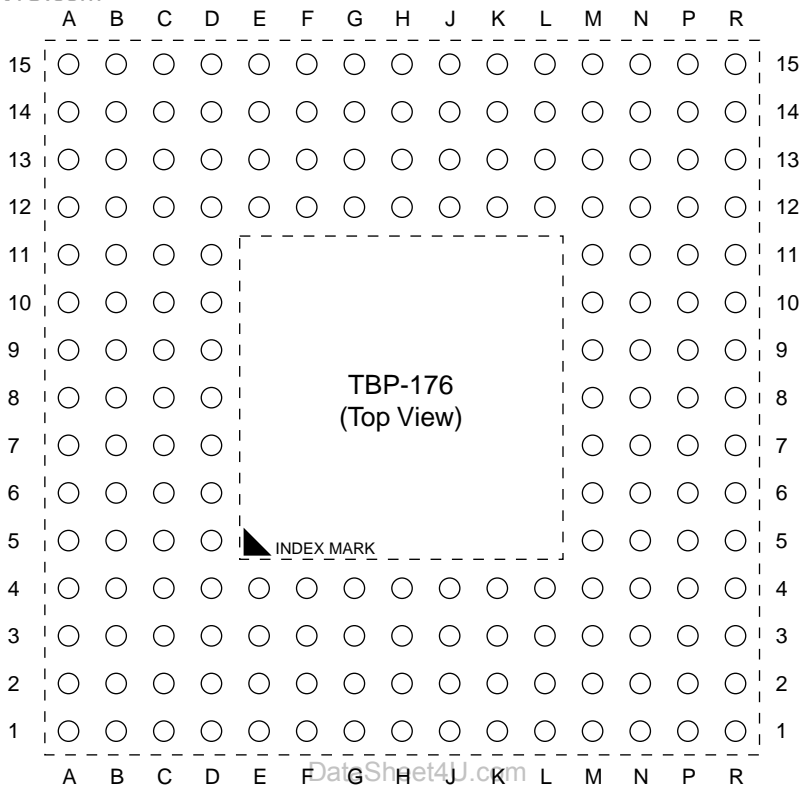

Figure 1.2 Pin Arrangement (144-Pin Plastic QFP)



Note: The part surrounded by the interrupt line is perspective.

Figure 1.3 Pin Arrangement (176-Pin Plastic TFBGA)

Table 1.2 shows the pin functions of the SH7604.

Table 1.1 Pin Functions

Pin No.				
FP-144	TBP-176	Pin Name	I/O	Pin Description
—	A1	NC	—	Reserved pin (leave unconnected)
—	C3	NC	—	Reserved pin (leave unconnected)
—	B1	NC	—	Reserved pin (leave unconnected)
—	C2	NC	—	Reserved pin (leave unconnected)
1	D3	D11	I/O	Data bus
2	C1	D12	I/O	Data bus
3	D2	D13	I/O	Data bus
4	E4	V _{CC}	I	Power
5	D1	D14	I/O	Data bus
6	E3	V _{SS}	I	Ground
7	E2	D15	I/O	Data bus
8	E1	D16	I/O	Data bus
9	F4	D17	I/O	Data bus
10	F3	D18	I/O	Data bus
11	F1	D19	I/O	Data bus
12	F2	V _{CC}	I	Power
13	G4	D20	I/O	Data bus
14	G3	V _{SS}	I	Ground
15	G1	D21	I/O	Data bus
16	G2	D22	I/O	Data bus
17	H4	D23	I/O	Data bus
18	H3	V _{CC}	I	Power
19	H1	D24	I/O	Data bus
20	H2	V _{SS}	I	Ground
21	J4	D25	I/O	Data bus
22	J3	D26	I/O	Data bus
23	J1	D27	I/O	Data bus
24	J2	V _{CC}	I	Power

Table 1.1 Pin Functions (cont)

Pin No.				
FP-144	TBP-176	Pin Name	I/O	Pin Description
25	K4	D28	I/O	Data bus
26	K3	V _{SS}	I	Ground
27	K1	D29	I/O	Data bus
28	K2	D30	I/O	Data bus
29	L3	D31	I/O	Data bus
30	L1	A0	I/O	Address bus
31	L2	A1	I/O	Address bus
32	L4	A2	I/O	Address bus
33	M1	V _{SS}	I	Ground
34	M2	A3	I/O	Address bus
35	M3	A4	I/O	Address bus
36	N1	A5	I/O	Address bus
—	M4	NC	—	Reserved pin (leave unconnected)
—	N2	NC	—	Reserved pin (leave unconnected)
—	P1	NC	—	Reserved pin (leave unconnected)
—	P2	NC	—	Reserved pin (leave unconnected)
—	R1	NC	—	Reserved pin (leave unconnected)
—	N3	NC	—	Reserved pin (leave unconnected)
—	R2	NC	—	Reserved pin (leave unconnected)
—	P3	NC	—	Reserved pin (leave unconnected)
37	N4	A6	I/O	Address bus
38	R3	A7	I/O	Address bus
39	P4	A8	I/O	Address bus
40	M5	V _{CC}	I	Power
41	R4	A9	I/O	Address bus
42	N5	V _{SS}	I	Ground
43	P5	A10	I/O	Address bus
44	R5	A11	I/O	Address bus
45	M6	A12	I/O	Address bus
46	N6	A13	I/O	Address bus
47	R6	A14	I/O	Address bus

Table 1.1 Pin Functions (cont)

Pin No.			I/O	Pin Description
FP-144	TBP-176	Pin Name		
48	P6	V _{CC}	I	Power
49	M7	A15	I/O	Address bus
50	N7	V _{SS}	I	Ground
51	R7	A16	I/O	Address bus
52	P7	A17	I/O	Address bus
53	M8	A18	I/O	Address bus
54	N8	V _{CC}	I	Power
55	R8	A19	I/O	Address bus
56	P8	V _{SS}	I	Ground
57	M9	A20	I/O	Address bus
58	N9	A21	I/O	Address bus
59	R9	A22	I/O	Address bus
60	P9	V _{CC}	I	Power
61	M10	A23	I/O	Address bus
62	N10	V _{SS}	I	Ground
63	R10	A24	I/O	Address bus
64	P10	A25	I/O	Address bus
65	N11	A26	I/O	Address bus
66	R11	DACK0	O	DMAC0 acknowledge
67	P11	V _{CC}	I	Power
68	M11	DACK1	O	DMAC1 acknowledge
69	R12	V _{SS}	I	Ground
70	P12	DREQ0	I	DMAC0 request
71	N12	DREQ1	I	DMAC1 request
72	R13	$\overline{CS0}$	O	Chip select 0
—	M12	NC	—	Reserved pin (leave unconnected)
—	P13	NC	—	Reserved pin (leave unconnected)
—	R14	NC	—	Reserved pin (leave unconnected)
—	P14	NC	—	Reserved pin (leave unconnected)
—	R15	NC	—	Reserved pin (leave unconnected)
—	N13	NC	—	Reserved pin (leave unconnected)

Table 1.1 Pin Functions (cont)

Pin No.				
FP-144	TBP-176	Pin Name	I/O	Pin Description
—	P15	NC	—	Reserved pin (leave unconnected)
—	N14	NC	—	Reserved pin (leave unconnected)
73	M13	$\overline{CS1}$	O	Chip select 1
74	N15	$\overline{CS2}$	O	Chip select 2
75	M14	$\overline{CS3}$	O	Chip select 3
76	L12	\overline{BS}	I/O	Bus cycle start
77	M15	RD/\overline{WR}	I/O	Read/write
78	L13	V_{SS}	I	Ground
79	L14	$\overline{RAS}/\overline{CE}$	O	RAS for DRAM and synchronous DRAM, CE for pseudo-SRAM
80	L15	$\overline{CAS}/\overline{OE}$	O	CAS for synchronous DRAM, OE for pseudo-SRAM
81	K12	$\overline{CASHH}/\overline{DQMUI}/\overline{WE3}$	O	Most significant byte selection signal for memory
82	K13	$\overline{CASHL}/\overline{DQMU}/\overline{WE2}$	O	Second byte selection signal for memory
83	K15	$\overline{CASLH}/\overline{DQMLU}/\overline{WE1}$	O	Third byte selection signal for memory
84	K14	V_{CC}	I	Power
85	J12	$\overline{CASLL}/\overline{DQMLL}/\overline{WE0}$	O	Least significant byte selection signal for memory
86	J13	V_{SS}	I	Ground
87	J15	\overline{RD}	O	Read pulse
88	J14	CKE	O	Synchronous DRAM clock enable control
89	H12	\overline{WAIT}	I	Hardware wait request
90	H13	NC	—	Reserved pin (leave unconnected)
91	H15	V_{SS}	I	Ground
92	H14	$\overline{BACK}/\overline{BRLS}$	I	Bus acknowledge in slave mode, bus request in master mode
93	G12	$\overline{BREQ}/\overline{BGR}$	O	Bus request in slave mode, bus grant in master mode
94	G13	\overline{WDTOVF}	O	Watchdog timer output
95	G15	FTOB	O	Free-running timer output B
96	G14	V_{CC}	I	Power

Table 1.1 Pin Functions (cont)

Pin No.				
FP-144	TBP-176	Pin Name	I/O	Pin Description
97	F12	FTOA	O	Free-running timer output A
98	F13	V _{SS}	I	Ground
99	F15	FTI	I	Free-running timer input
100	F14	FTCI	I	Free-running timer clock input
101	E13	RxD	I	Serial data input
102	E15	TxD	O	Serial data output
103	E14	SCK	I/O	Serial clock input/output
104	E12	V _{CC} (PLL)	I	Power for on-chip PLL
105	D15	MD0	I	Operating mode pin
106	D14	V _{SS} (PLL)	I	Ground for on-chip PLL
107	D13	MD1	I	Operating mode pin
108	C15	CAP1	O	External capacitance pin for PLL
—	D12	NC	—	Reserved pin (leave unconnected)
—	C14	NC	—	Reserved pin (leave unconnected)
—	B15	NC	—	Reserved pin (leave unconnected)
—	B14	NC	—	Reserved pin (leave unconnected)
—	A15	NC	—	Reserved pin (leave unconnected)
—	C13	NC	—	Reserved pin (leave unconnected)
—	A14	NC	—	Reserved pin (leave unconnected)
—	B13	NC	—	Reserved pin (leave unconnected)
109	C12	CAP2	O	External capacitance pin for PLL
110	A13	MD2	I	Operating mode pin
111	B12	$\overline{\text{CKPACK}}$	O	Clock pause acknowledge output
112	D11	$\overline{\text{CKPREQ/CKM}}$	I	Clock pause request input
113	A12	V _{CC}	I	Power
114	C11	EXTAL	I	Pin for connecting crystal resonator
115	B11	V _{SS}	I	Ground
116	A11	XTAL	O	Pin for connecting crystal resonator
117	D10	MD3	I	Operating mode pin
118	C10	CKIO	I/O	System clock input/output
119	A10	MD4	I	Operating mode pin

Table 1.1 Pin Functions (cont)

Pin No.				
FP-144	TBP-176	Pin Name	I/O	Pin Description
120	B10	MD5	I	Operating mode pin
121	D9	V _{SS}	I	Ground
122	C9	$\overline{\text{RES}}$	I	Reset
123	A9	V _{CC}	Power	Power
124	B9	$\overline{\text{IVECF}}$	O	Interrupt vector fetch cycle
125	D8	NMI	I	Nonmaskable interrupt request
126	C8	$\overline{\text{IRL3}}$	I	External interrupt source input
127	A8	$\overline{\text{IRL2}}$	I	External interrupt source input
128	B8	$\overline{\text{IRL1}}$	I	External interrupt source input
129	D7	$\overline{\text{IRL0}}$	I	External interrupt source input
130	C7	D0	I/O	Data bus
131	A7	D1	I/O	Data bus
132	B7	V _{CC}	I	Power
133	D6	D2	I/O	Data bus
134	C6	V _{SS}	I	Ground
135	A6	D3	I/O	Data bus
136	B6	D4	I/O	Data bus
137	C5	D5	I/O	Data bus
138	A5	D6	I/O	Data bus
139	B5	V _{CC}	I	Power
140	D5	D7	I/O	Data bus
141	A4	V _{SS}	I	Ground
142	B4	D8	I/O	Data bus
143	C4	D9	I/O	Data bus
144	A3	D10	I/O	Data bus
—	D4	NC	—	Reserved pin (leave unconnected)
—	B3	NC	—	Reserved pin (leave unconnected)
—	A2	NC	—	Reserved pin (leave unconnected)
—	B2	NC	—	Reserved pin (leave unconnected)

Section 2 CPU

2.1 Register Configuration

The register set consists of sixteen 32-bit general registers, three 32-bit control registers and four 32-bit system registers.

2.1.1 General Registers

The 16 general registers (R0–R15) are shown in figure 2.1. General registers are used for data processing and address calculation. R0 is also used as an index register, and several instructions use R0 as a fixed source or destination register. R15 is used as the hardware stack pointer (SP). Saving and recovering the status register (SR) and program counter (PC) in exception handling is accomplished by referencing the stack using R15.

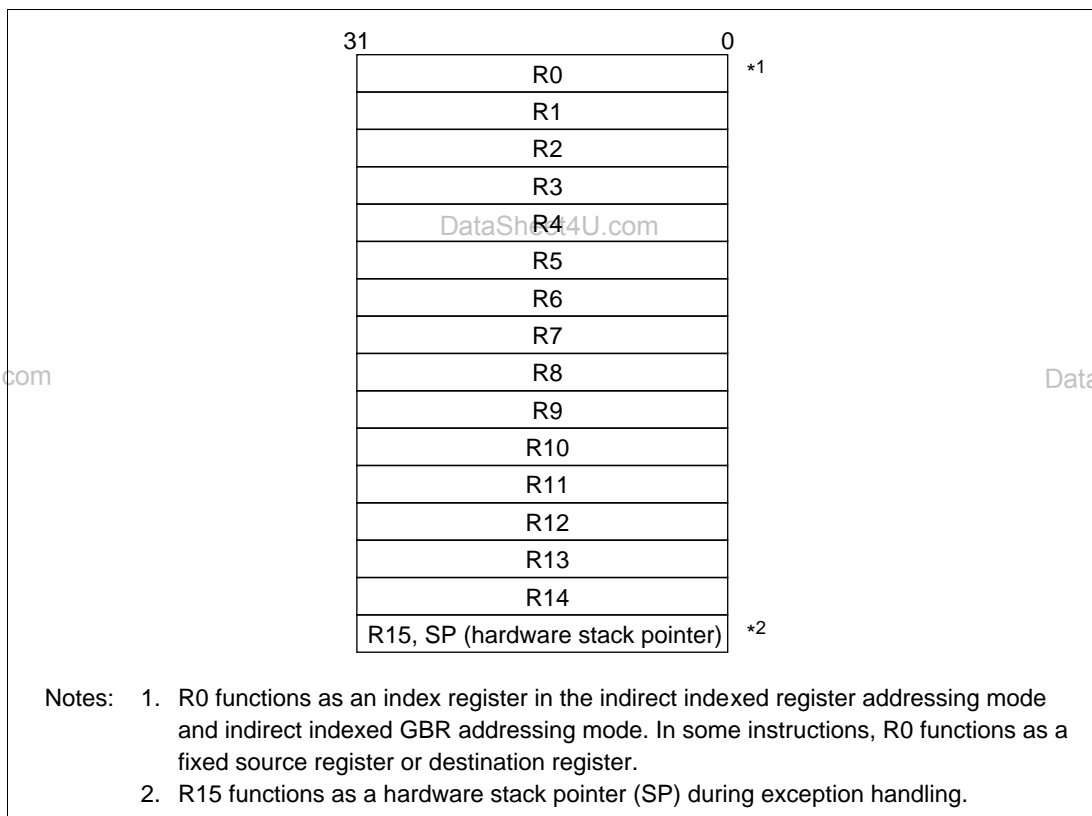

Figure 2.1 General Registers

The 32-bit control registers consist of the 32-bit status register (SR), global base register (GBR), and vector base register (VBR) (figure 2.2). The status register indicates processing states. The global base register functions as a base address for the GBR indirect addressing mode to transfer data to the registers of on-chip peripheral modules. The vector base register functions as the base address of the exception handling vector area (including interrupts).

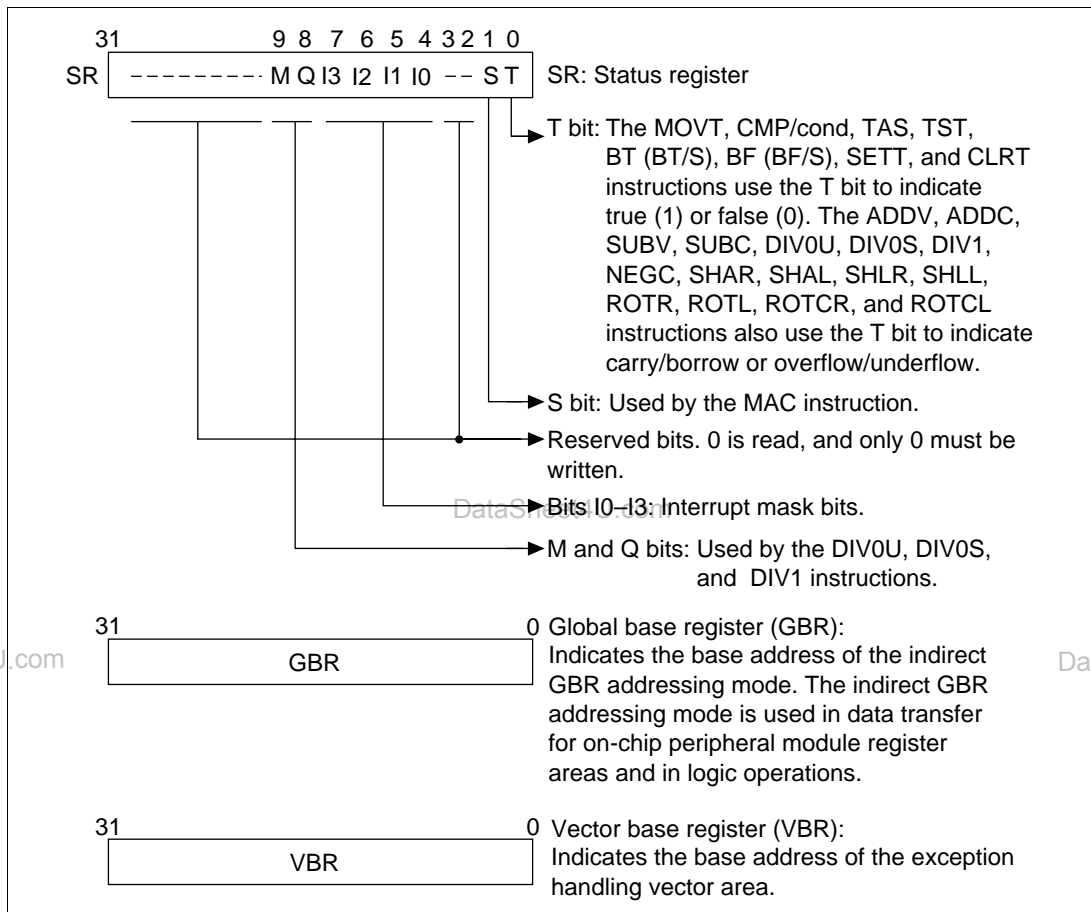

Figure 2.2 Control Registers

2.1.3 System Registers

System registers consist of four 32-bit registers: high and low multiply-and-accumulate registers (MACH and MACL), the procedure register (PR), and the program counter (PC) (figure 2.3). The multiply-and-accumulate registers store the results of multiply and accumulate operations. The procedure register stores the return address from the subroutine procedure. The program counter stores program addresses to control the flow of the processing.

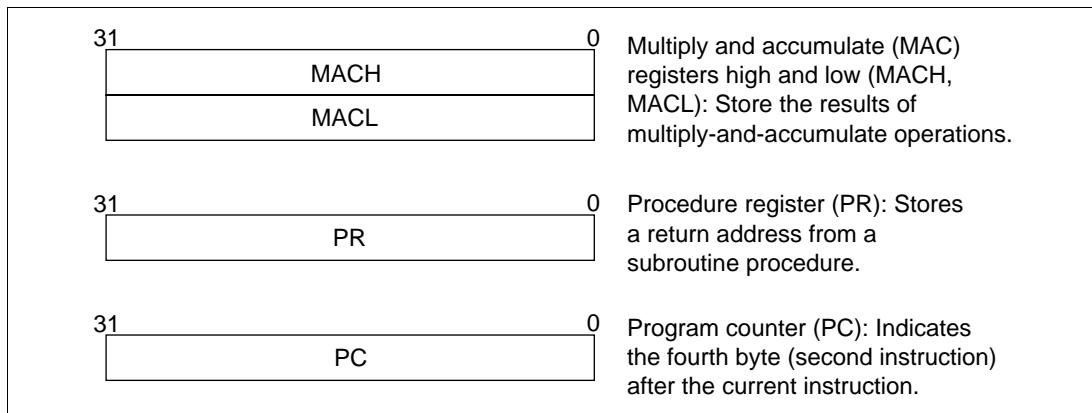

Figure 2.3 System Registers

2.1.4 Initial Values of Registers

DataSheet4U.com

Table 2.1 lists the values of the registers after a reset.

Table 2.1 Initial Values of Registers

DataSheet4U.com

Classification	Register	Initial Value
General registers	R0–R14	Undefined
	R15A (SP)	Value of the stack pointer in the vector address table
Control registers	SR	Bits I3–I0 are 1111 (H'F), reserved bits are 0, and other bits are undefined
	GBR	Undefined
	VBR	H'00000000
System registers	MACH, MACL, PR	Undefined
	PC	Value of the program counter in the vector address table

2.2.1 Data Format in Registers

Register operands are always longwords (32 bits) (figure 2.4). When the memory operand is only a byte (8 bits) or a word (16 bits), it is sign-extended into a longword when loaded into a register.

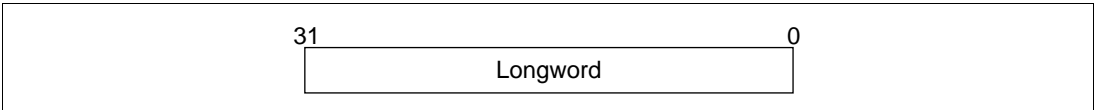

Figure 2.4 Longword Operand

2.2.2 Data Format in Memory

Memory data formats are classified into bytes, words, and longwords. Byte data can be accessed at any address, but an address error will occur if you try to access word data starting from an address other than $2n$ or longword data starting from an address other than $4n$. In such cases, the data accessed cannot be guaranteed (figure 2.5). The hardware stack area, referred to by the hardware stack pointer (SP, R15), uses only longword data starting from address $4n$ because this area holds the program counter and status register.

This microprocessor has a function that allows access of CS2 space (area 2) in little-endian format, which enables the microprocessor to share memory with processors that access memory in little-endian format. The microprocessor arranges byte data differently for little-endian and the more usual big-endian format.

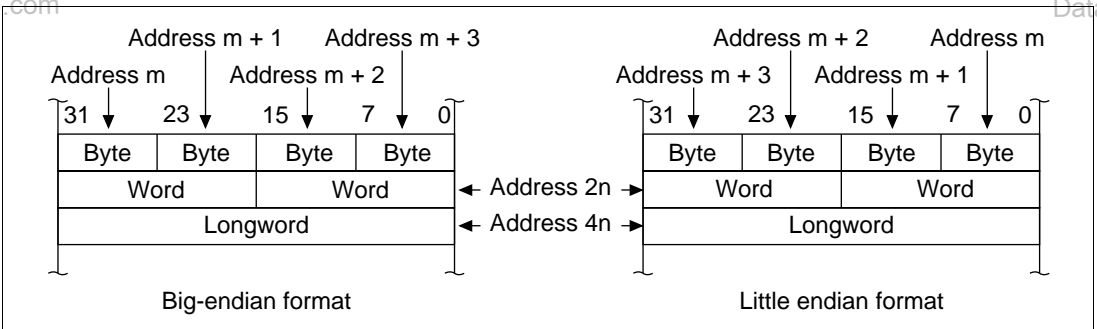

Figure 2.5 Byte, Word, and Longword Alignment

2.2.3 Immediate Data Format

Byte (8-bit) immediate data resides in an instruction code. Immediate data accessed by the MOV, ADD, and CMP/EQ instructions is sign-extended and handled in registers as longword data. Immediate data accessed by the TST, AND, OR, and XOR instructions is zero-extended and handled as longword data. Consequently, AND instructions with immediate data always clear the upper 24 bits of the destination register.

Word or longword immediate data is not located in the instruction code: it is stored in a memory table. An immediate data transfer instruction (MOV) accesses the memory table using the PC relative with displacement addressing mode. Specific examples are given in table 2.5, Immediate Data Accessing.

2.3 Instruction Features

2.3.1 RISC-Type Instruction Set

All instructions are RISC type. This section details their functions.

16-Bit Fixed Length: All instructions are 16 bits long, increasing program code efficiency.

One Instruction per Cycle: The microprocessor can execute basic instructions in one cycle using the pipeline system. Instructions are executed in 35 ns at 28.7 MHz.

Data Length: Longword is the standard data length for all operations. Memory can be accessed in bytes, words, or longwords. Byte or word data accessed from memory is sign-extended and handled as longword data (table 2.2). Immediate data is sign-extended for arithmetic operations or zero-extended for logic operations. It also is handled as longword data.

Table 2.2 Sign Extension of Word Data

SH7604 CPU	Description	Example of Conventional CPU
MOV.W @(disp,PC),R1	Data is sign-extended to 32 bits, and R1 becomes H'00001234. It is next operated upon by an ADD instruction.	ADD.W #H'1234,R0
ADD R1,R0		
.....		
.DATA.W H'1234		

Note: @(disp, PC) accesses the immediate data.

Load-Store Architecture: Basic operations are executed between registers. For operations that involve memory access, data is loaded into the registers and executed (load-store architecture).

Instructions such as AND that manipulate bits, however, are executed directly in memory.

Delayed Branch Instructions: Unconditional branch instructions are delayed. Executing the instruction that follows the branch instruction, before branching reduces pipeline disruption during branching (table 2.3).

Table 2.3 Delayed Branch Instructions

SH7604 Series CPU		Description	Example of Conventional CPU	
BRA	TRGET	Executes ADD before branching to TRGET	ADD.W	R1, R0
ADD	R1, R0		BRA	TRGET

Multiply and Multiply-and-Accumulate Operations: 16-bit \times 16-bit \rightarrow 32-bit multiply operations are executed in one to two states. 16-bit \times 16-bit + 64-bit \rightarrow 64-bit multiply-and-accumulate operations are executed in two to three states. 32-bit \times 32-bit \rightarrow 64-bit multiply and 32-bit \times 32-bit + 64bit \rightarrow 64-bit multiply-and-accumulate operations are executed in two to four states.

T Bit: The T bit in the status register changes according to the result of the comparison, and in turn is the condition (true/false) that determines if the program will branch (table 2.4). The number of instructions that change the T bit is kept to a minimum to improve the processing speed.

Table 2.4 T Bit

SH7604 CPU		Description	Example of Conventional CPU	
CMP/GE	R1, R0	T bit is set when $R0 \geq R1$. The program branches to TRGET0 when $R0 \geq R1$ and to TRGET1 when $R0 < R1$.	CMP.W	R1, R0
BT	TRGET0		BGE	TRGET0
BF	TRGET1		BLT	TRGET1
ADD	#-1, R0	T bit is not changed by ADD. T bit is set when $R0 = 0$. The program branches if $R0 = 0$.	SUB.W	#1, R0
CMP/EQ	#0, R0		BEQ	TRGET
BT	TRGET			

Immediate Data: Byte (8-bit) immediate data resides in the instruction code. Word or longword immediate data is not input via instruction codes but is stored in a memory table. An immediate data transfer instruction (MOV) accesses the memory table using the PC relative with displacement addressing mode (table 2.5).

Table 2.5 Immediate Data Accessing

Classification	SH7604 CPU		Example of Conventional CPU	
8-bit immediate	MOV	#H'12,R0	MOV.B	#H'12,R0
16-bit immediate	MOV.W	@(disp,PC),R0	MOV.W	#H'1234,R0
			
	.DATA.W	H'1234		
32-bit immediate	MOV.L	@(disp,PC),R0	MOV.L	#H'12345678,R0
			
	.DATA.L	H'12345678		

Note: @(disp, PC) accesses the immediate data.

Absolute Address: When data is accessed by absolute address, the absolute address value is placed in the memory table beforehand. Loading the immediate data when the instruction is executed transfers that value to the register and the data is accessed in the register indirect addressing mode (table 2.6).

Table 2.6 Absolute Address Accessing

Classification	SH7604 CPU		Example of Conventional CPU	
Absolute address	MOV.L	@(disp,PC),R1	MOV.B	@H'12345678,R0
	MOV.B	@R1,R0		
			
	.DATA.L	H'12345678		

Note: @(disp,PC) accesses the immediate data.

16-Bit/32-Bit Displacement: When data is accessed by 16-bit or 32-bit displacement, the displacement value is placed in the memory table beforehand. Loading the immediate data when the instruction is executed transfers that value to the register and the data is accessed in the indexed register indirect addressing addressing mode (table 2.7).

Table 2.7 16/32-Bit Displacement Accessing

Classification	SH7604 CPU		Example of Conventional CPU	
16-bit displacement	MOV.W	@(disp,PC),R0	MOV.W	@(H'1234,R1),R2
	MOV.W	@(R0,R1),R2		
			
	.DATA.W	H'1234		

Note: @(disp,PC) accesses the immediate data.

Table 2.8 shows addressing modes and effective address calculation.

Table 2.8 Addressing Modes and Effective Addresses

Addressing Mode	Instruction Format	Effective Addresses Calculation	Equation
Register direct	Rn	The effective address is register Rn. (The operand is the contents of register Rn.)	—
Register indirect	@Rn	The effective address is the contents of register Rn. 	Rn
Register indirect with post-increment	@Rn+	The effective address is the contents of register Rn. A constant is added to the contents of Rn after the instruction is executed. 1 is added for a byte operation, 2 for a word operation, and 4 for a longword operation. 	Rn (After the instruction executes) Byte: Rn + 1 → Rn Word: Rn + 2 → Rn Longword: Rn + 4 → Rn
Register indirect with pre-decrement	@-Rn	The effective address is the value obtained by subtracting a constant from Rn. 1 is subtracted for a byte operation, 2 for a word operation, and 4 for a longword operation. 	Byte: Rn - 1 → Rn Word: Rn - 2 → Rn Longword: Rn - 4 → Rn (Instruction executed with Rn after calculation)

Table 2.8 Addressing Modes and Effective Addresses (cont)

Addressing Mode	Instruction Format	Effective Addresses Calculation	Equation
Register indirect with displacement	@(disp:4, Rn)	The effective address is Rn plus a 4-bit displacement (disp). The value of disp is zero-extended, and remains the same for a byte operation, is doubled for a word operation, and is quadrupled for a longword operation.	Byte: $Rn + disp$ Word: $Rn + disp \times 2$ Longword: $Rn + disp \times 4$
Indexed register indirect	@(R0, Rn)	The effective address is the Rn value plus R0.	$Rn + R0$
GBR indirect with displacement	@(disp:8, GBR)	The effective address is the GBR value plus an 8-bit displacement (disp). The value of disp is zero-extended, and remains the same for a byte operation, is doubled for a word operation, and is quadrupled for a longword operation.	Byte: $GBR + disp$ Word: $GBR + disp \times 2$ Longword: $GBR + disp \times 4$
Indexed GBR indirect	@(R0, GBR)	The effective address is the GBR value plus the R0 value.	$GBR + R0$

Table 2.8 Addressing Modes and Effective Addresses (cont)

Addressing Mode	Instruction Format	Effective Addresses Calculation	Equation
PC relative with displacement	@(disp:8, PC)	The effective address is the PC value plus an 8-bit displacement (disp). The value of disp is zero-extended, and remains the same for a byte operation, is doubled for a word operation, and is quadrupled for a longword operation. For a longword operation, the lowest two bits of the PC value are masked.	Word: $PC + disp \times 2$ Longword: $PC \& H'FFFFFFFC + disp \times 4$
PC relative	disp:8	The effective address is the PC value sign-extended with an 8-bit displacement (disp), doubled, and added to the PC value.	$PC + disp \times 2$
	disp:12	The effective address is the PC value sign-extended with a 12-bit displacement (disp), doubled, and added to the PC value.	$PC + disp \times 2$

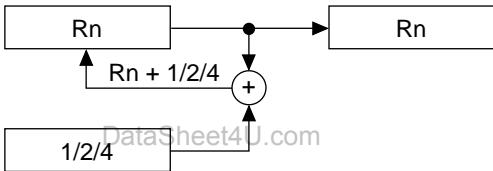
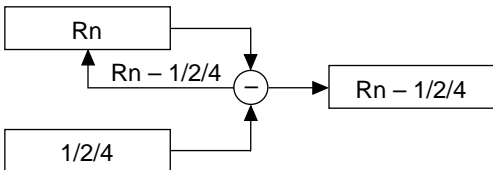
Table 2.8 Addressing Modes and Effective Addresses (cont)

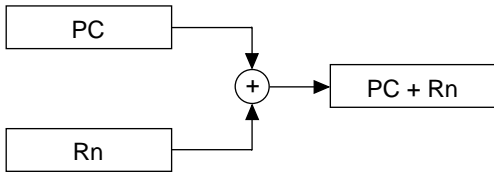
Addressing Mode	Instruction Format	Effective Addresses Calculation	Equation
PC relative (cont)	Rn	The effective address is the register PC value plus Rn. 	$PC + Rn$
Immediate	#imm:8	The 8-bit immediate data (imm) for the TST, AND, OR, and XOR instructions is zero-extended.	—
	#imm:8	The 8-bit immediate data (imm) for the MOV, ADD, and CMP/EQ instructions is sign-extended.	—
	#imm:8	The 8-bit immediate data (imm) for the TRAPA instruction is zero-extended and quadrupled.	—

2.3.3 Instruction Formats

Table 2.9 shows instruction formats and source and destination operands. The meaning of the operands depends on the instruction code. The following symbols are used in the table:

- xxxx: Instruction code
- mmmm: Source register
- nnnn: Destination register
- iiiii: Immediate data
- dddd: Displacement

Table 2.9 Instruction Formats

Instruction Format	Source Operand	Destination Operand	Example				
0 format <div style="border: 1px solid black; padding: 2px; width: fit-content; margin: 5px auto;"> 15 0 <div style="display: flex; justify-content: space-around; width: 100%;"> xxxx xxxx xxxx xxxx </div> </div>	—	—	NOP				
n format <div style="border: 1px solid black; padding: 2px; width: fit-content; margin: 5px auto;"> 15 0 <table border="1" style="border-collapse: collapse; width: 100%;"> <tr> <td style="width: 25%;">xxxx</td> <td style="width: 10%;">nnnn</td> <td style="width: 25%;">xxxx</td> <td style="width: 25%;">xxxx</td> </tr> </table> </div>	xxxx	nnnn	xxxx	xxxx	—	nnnn: Register direct	MOVT Rn
xxxx	nnnn	xxxx	xxxx				
	Control register or system register	nnnn: Register direct	STS MACH, Rn				
	Control register or system register	nnnn: Register indirect with pre-decrement	STC.L SR, @-Rn				
m format <div style="border: 1px solid black; padding: 2px; width: fit-content; margin: 5px auto;"> 15 0 <table border="1" style="border-collapse: collapse; width: 100%;"> <tr> <td style="width: 15%;">xxxx</td> <td style="width: 15%;">mmmm</td> <td style="width: 15%;">xxxx</td> <td style="width: 15%;">xxxx</td> </tr> </table> </div>	xxxx	mmmm	xxxx	xxxx	mmmm: Register direct	Control register or system register	LDC Rm, SR
xxxx	mmmm	xxxx	xxxx				
	mmmm: Register indirect with post-increment	Control register or system register	LDC.L @Rm+, SR				
	mmmm: Register indirect	—	JMP @Rm				
	mmmm: PC relative using Rm	—	BRAF Rm				

Table 2.9 Instruction Formats (cont)

Instruction Format	Source Operand	Destination Operand	Example
nm format	mmmm: Register direct	nxxx: Register direct	ADD Rm, Rn
15 <div style="border: 1px solid black; padding: 2px; display: inline-block;"> xxxx nnnn mmmm xxxx </div> 0	mmmm: Register direct	nxxx: Register indirect	MOV.L Rm, @Rn
	mmmm: Register indirect with post-increment (multiply-and-accumulate) nnnn: Register indirect with post-increment (multiply-and-accumulate)*	MACH, MACL	MAC.W @Rm+, @Rn+
	mmmm: Register indirect with post-increment	nxxx: Register direct	MOV.L @Rm+, Rn
	mmmm: Register direct	nxxx: Register indirect with pre-decrement	MOV.L Rm, @-Rn
	mmmm: Register direct	nxxx: Indexed register indirect	MOV.L Rm, @(R0, Rn)
md format	mmmmdddd: Register indirect with displacement	R0 (Register direct)	MOV.B @(disp, Rn), R0
15 <div style="border: 1px solid black; padding: 2px; display: inline-block;"> xxxx xxxx mmmm dddd </div> 0			
nd4 format	R0 (Register direct)	nnnndddd: Register indirect with displacement	MOV.B R0, @(disp, Rn)
15 <div style="border: 1px solid black; padding: 2px; display: inline-block;"> xxxx xxxx nnnn dddd </div> 0			
nmd format	mmmm: Register direct	nnnndddd: Register indirect with displacement	MOV.L Rm, @(disp, Rn)
15 <div style="border: 1px solid black; padding: 2px; display: inline-block;"> xxxx nnnn mmmm dddd </div> 0			
	mmmmdddd: Register indirect with displacement	nnnn: Register direct	MOV.L @(disp, Rm), Rn

Table 2.9 Instruction Formats (cont)

Instruction Format	Source Operand	Destination Operand	Example
d format 15 0 <div style="border: 1px solid black; padding: 2px; display: inline-block;"> xxxx xxxx dddd dddd </div>	dddddddd: GBR indirect with displacement	R0 (Register direct)	MOV.L @(disp,GBR),R0
	R0 (Register direct)	dddddddd: GBR indirect with displacement	MOV.L R0,@(disp,GBR)
	dddddddd: PC relative with displacement	R0 (Register direct)	MOVA @(disp,PC),R0
	dddddddd: PC relative	—	BF label
d12 format 15 0 <div style="border: 1px solid black; padding: 2px; display: inline-block;"> xxxx dddd dddd dddd </div>	dddddddddddd: PC relative	—	BRA label (label = disp + PC)
nd8 format 15 0 <div style="border: 1px solid black; padding: 2px; display: inline-block;"> xxxx nnnn dddd dddd </div>	dddddddd: PC relative with displacement	nnnn: Register direct	MOV.L @(disp,PC),Rn
i format 15 0 <div style="border: 1px solid black; padding: 2px; display: inline-block;"> xxxx xxxx iiii iiii </div>	iiii: Immediate Immediate	Indexed GBR indirect	AND.B #imm,@(R0,GBR)
	iiii: Immediate Immediate	R0 (Register direct)	AND #imm,R0
	iiii: Immediate Immediate	—	TRAPA #imm
ni format 15 0 <div style="border: 1px solid black; padding: 2px; display: inline-block;"> xxxx nnnn iiii iiii </div>	iiii: Immediate Immediate	nnnn: Register direct	ADD #imm,Rn

Note: In multiply-and-accumulate instructions, nnnn is the source register.

2.4 Instruction Set

2.4.1 Instruction Set by Classification

Table 2.10 Instruction Set by Classification

Classification	Types	Operation		Number of Instructions
		Code	Function	
Data transfer	5	MOV	Data transfer, immediate data transfer, peripheral module data transfer, structure data transfer	39
		MOVA	Effective address transfer	
		MOV T	T bit transfer	
		SWAP	Swap of upper and lower bytes	
		XTRCT	Extraction of middle of connected registers	
Arithmetic operations	21	ADD	Binary addition	33
		ADDC	Binary addition with carry	
		ADDV	Binary addition with overflow check	
		CMP/cond	Comparison	
		DIV1	Division	
		DIV0S	Initialization of signed division	
		DIV0U	Initialization of unsigned division	
		DMULS	Signed double-length multiplication	
		DMULU	Unsigned double-length multiplication	
		DT	Decrement and test	
		EXTS	Sign extension	
		EXTU	Zero extension	
		MAC	Multiply-and-accumulate, double-length multiply-and-accumulate operation	
		MUL	Double-length multiplication	
		MULS	Signed multiplication	
		MULU	Unsigned multiplication	
		NEG	Negation	
		NEGC	Negation with borrow	
		SUB	Binary subtraction	
SUBC	Binary subtraction with borrow	www.DataSheet4U.com		
SUBV	Binary subtraction with underflow check			

Table 2.10 Instruction Set by Classification (cont)

Classification	Types	Operation Code	Function	Number of Instructions
Logic operations	6	AND	Logical AND	14
		NOT	Bit inversion	
		OR	Logical OR	
		TAS	Memory test and bit set	
		TST	Logical AND and T bit set	
		XOR	Exclusive OR	
Shift	10	ROTL	One-bit left rotation	14
		ROTR	One-bit right rotation	
		ROTCL	One-bit left rotation with T bit	
		ROTCR	One-bit right rotation with T bit	
		SHAL	One-bit arithmetic left shift	
		SHAR	One-bit arithmetic right shift	
		SHLL	One-bit logical left shift	
		SHLLn	n-bit logical left shift	
		SHLR	One-bit logical right shift	
		SHLRn	n-bit logical right shift	
Branch	9	BF	Conditional branch, conditional branch with delay (T = 0)	11
		BT	Conditional branch, conditional branch with delay (T = 1)	
		BRA	Unconditional branch	
		BRAF	Unconditional branch	
		BSR	Branch to subroutine procedure	
		BSRF	Branch to subroutine procedure	
		JMP	Unconditional branch	
		JSR	Branch to subroutine procedure	
		RTS	Return from subroutine procedure	

Table 2.10 Instruction Set by Classification (cont)

Classification	Types	Operation		Number of Instructions
		Code	Function	
System control	11	CLRT	T bit clear	31
		CLRMAC	MAC register clear	
		LDC	Load to control register	
		LDS	Load to system register	
		NOP	No operation	
		RTE	Return from exception handling	
		SETT	T bit set	
		SLEEP	Shift to power-down state	
		STC	Store control register data	
		STS	Store system register data	
	TRAPA	Trap exception handling		
Total:62				142

DataSheet4U.com

et4U.com

DataShee

DataSheet4U.com

www.DataSheet4U.com

DataSheet4U.com

Table 2.11 Instruction Code Format

Item	Format	Explanation
Instruction mnemonic	OP . Sz SRC , DEST	OP: Operation code Sz: Size (B: byte, W: word, or L: longword) SRC: Source DEST: Destination Rm: Source register Rn: Destination register imm: Immediate data disp: Displacement* ¹
Instruction code	MSB ↔ LSB	m m m m: Source register n n n n: Destination register 0000: R0 0001: R1 1111: R15 iiii: Immediate data d d d d: Displacement
Operation summary	→, ←	Direction of transfer
	(xx)	Memory operand
	M/Q/T	Flag bits in SR
	&	Logical AND of each bit
		Logical OR of each bit
	^	Exclusive OR of each bit
	~	Logical NOT of each bit
	<<n, >>n	n-bit shift
Execution states	—	Value when no wait states are inserted* ²
T bit	—	Value of T bit after instruction is executed. An em-dash (—) in the column means no change.

Notes: 1. Depending on the operand size, displacement is scaled $\times 1$, $\times 2$, or $\times 3$. For details, see the SH-1/SH-2 programming manual.

2. Instruction execution states: The execution states shown in the table are minimums. The actual number of states may be increased when:

- Contention occurs between instruction fetch and data access
- The destination register of the load instruction (memory → register) and the register used by the next instruction are the same.

Table 2.12 Data Transfer Instructions

Instruction	Instruction Code	Operation	Execution States	T Bit
MOV #imm,Rn	1110nnnniiiiiiii	#imm → Sign extension → Rn	1	—
MOV.W @(disp,PC),Rn	1001nnnndddddddd	(disp × 2 + PC) → Sign extension → Rn	1	—
MOV.L @(disp,PC),Rn	1101nnnndddddddd	(disp × 4 + PC) → Rn	1	—
MOV Rm,Rn	0110nnnnmmmm0011	Rm → Rn	1	—
MOV.B Rm,@Rn	0010nnnnmmmm0000	Rm → (Rn)	1	—
MOV.W Rm,@Rn	0010nnnnmmmm0001	Rm → (Rn)	1	—
MOV.L Rm,@Rn	0010nnnnmmmm0010	Rm → (Rn)	1	—
MOV.B @Rm,Rn	0110nnnnmmmm0000	(Rm) → Sign extension → Rn	1	—
MOV.W @Rm,Rn	0110nnnnmmmm0001	(Rm) → Sign extension → Rn	1	—
MOV.L @Rm,Rn	0110nnnnmmmm0010	(Rm) → Rn	1	—
MOV.B Rm,@-Rn	0010nnnnmmmm0100	Rn-1 → Rn, Rm → (Rn)	1	—
MOV.W Rm,@-Rn	0010nnnnmmmm0101	Rn-2 → Rn, Rm → (Rn)	1	—
MOV.L Rm,@-Rn	0010nnnnmmmm0110	Rn-4 → Rn, Rm → (Rn)	1	—
MOV.B @Rm+,Rn	0110nnnnmmmm0100	(Rm) → Sign extension → Rn, Rm + 1 → Rm	1	—
MOV.W @Rm+,Rn	0110nnnnmmmm0101	(Rm) → Sign extension → Rn, Rm + 2 → Rm	1	—
MOV.L @Rm+,Rn	0110nnnnmmmm0110	(Rm) → Rn, Rm + 4 → Rm	1	—
MOV.B R0,@(disp,Rn)	10000000nnnndddd	R0 → (disp + Rn)	1	—
MOV.W R0,@(disp,Rn)	10000001nnnndddd	R0 → (disp × 2 + Rn)	1	—
MOV.L Rm,@(disp,Rn)	0001nnnnmmmmdddd	Rm → (disp × 4 + Rn)	1	—
MOV.B @(disp,Rm),R0	10000100mmmmdddd	(disp + Rm) → Sign extension → R0	1	—
MOV.W @(disp,Rm),R0	10000101mmmmdddd	(disp × 2 + Rm) → Sign extension → R0	1	—
MOV.L @(disp,Rm),Rn	0101nnnnmmmmdddd	(disp × 4 + Rm) → Rn	1	—
MOV.B Rm,@(R0,Rn)	0000nnnnmmmm0100	Rm → (R0 + Rn)	1	—
MOV.W Rm,@(R0,Rn)	0000nnnnmmmm0101	Rm → (R0 + Rn)	1	—
MOV.L Rm,@(R0,Rn)	0000nnnnmmmm0110	Rm → (R0 + Rn)	1	—

Table 2.12 Data Transfer Instructions (cont)

Instruction	Instruction Code	Operation	Execution States	T Bit
MOV.B @(R0,Rm),Rn	0000nnnnmmmm1100	(R0 + Rm) → Sign extension → Rn	1	—
MOV.W @(R0,Rm),Rn	0000nnnnmmmm1101	(R0 + Rm) → Sign extension → Rn	1	—
MOV.L @(R0,Rm),Rn	0000nnnnmmmm1110	(R0 + Rm) → Rn	1	—
MOV.B R0,@(disp,GBR)	11000000ddddddd	R0 → (disp + GBR)	1	—
MOV.W R0,@(disp,GBR)	11000001ddddddd	R0 → (disp × 2 + GBR)	1	—
MOV.L R0,@(disp,GBR)	11000010ddddddd	R0 → (disp × 4 + GBR)	1	—
MOV.B @(disp,GBR),R0	11000100ddddddd	(disp + GBR) → Sign extension → R0	1	—
MOV.W @(disp,GBR),R0	11000101ddddddd	(disp × 2 + GBR) → Sign extension → R0	1	—
MOV.L @(disp,GBR),R0	11000110ddddddd	(disp × 4 + GBR) → R0	1	—
MOVA @(disp,PC),R0	11000111ddddddd	disp × 4 + PC → R0	1	—
MOVT Rn	0000nnnn00101001	T → Rn	1	—
SWAP.B Rm,Rn	0110nnnnmmmm1000	Rm → Swap the bottom two bytes → Rn	1	—
SWAP.W Rm,Rn	0110nnnnmmmm1001	Rm → Swap two consecutive words → Rn	1	—
XTRCT Rm,Rn	0010nnnnmmmm1101	Rm: Middle 32 bits of Rn → Rn	1	—

Table 2.13 Arithmetic Instructions

Instruction		Instruction Code	Operation	Execution States	T Bit
ADD	Rm, Rn	0011nnnnmmmm1100	$Rn + Rm \rightarrow Rn$	1	—
ADD	#imm, Rn	0111nnnniiiiiii	$Rn + imm \rightarrow Rn$	1	—
ADDC	Rm, Rn	0011nnnnmmmm1110	$Rn + Rm + T \rightarrow Rn$, Carry $\rightarrow T$	1	Carry
ADDV	Rm, Rn	0011nnnnmmmm1111	$Rn + Rm \rightarrow Rn$, Overflow $\rightarrow T$	1	Overflow
CMP/EQ	#imm, R0	10001000iiiiiii	If $R0 = imm$, $1 \rightarrow T$	1	Comparison result
CMP/EQ	Rm, Rn	0011nnnnmmmm0000	If $Rn = Rm$, $1 \rightarrow T$	1	Comparison result
CMP/HS	Rm, Rn	0011nnnnmmmm0010	If $Rn \geq Rm$ with unsigned data, $1 \rightarrow T$	1	Comparison result
CMP/GE	Rm, Rn	0011nnnnmmmm0011	If $Rn \geq Rm$ with signed data, $1 \rightarrow T$	1	Comparison result
CMP/HI	Rm, Rn	0011nnnnmmmm0110	If $Rn > Rm$ with unsigned data, $1 \rightarrow T$	1	Comparison result
CMP/GT	Rm, Rn	0011nnnnmmmm0111	If $Rn > Rm$ with signed data, $1 \rightarrow T$	1	Comparison result
CMP/PZ	Rn	0100nnnn00010001	If $Rn \geq 0$, $1 \rightarrow T$	1	Comparison result
CMP/PL	Rn	0100nnnn00010101	If $Rn > 0$, $1 \rightarrow T$	1	Comparison result
CMP/ST	Rm, Rn	0010nnnnmmmm1100	If Rn and Rm have an equivalent byte, $1 \rightarrow T$	1	Comparison result
DIV1	Rm, Rn	0011nnnnmmmm0100	Single-step division ($Rn \div Rm$)	1	Calculation result
DIV0S	Rm, Rn	0010nnnnmmmm0111	MSB of Rn $\rightarrow Q$, MSB of Rm $\rightarrow M$, $M \wedge Q \rightarrow T$	1	Calculation result
DIV0U		000000000011001	$0 \rightarrow M/Q/T$	1	0
DMULS.	Rm, Rn	0011nnnnmmmm1101	Signed operation of $Rn \times Rm \rightarrow MACH$, $MACL 32 \times 32 \rightarrow 64$ bits	2 to 4*	—

Table 2.13 Arithmetic Instructions (cont)

Instruction	Instruction Code	Operation	Execution States	T Bit
DMULU.L Rm, Rn	0011nnnnmmmm0101	Unsigned operation of $Rn \times Rm \rightarrow$ MACH, MACL $32 \times 32 \rightarrow 64$ bit	2 to 4*	—
DT Rn	0100nnnn00010000	$Rn - 1 \rightarrow Rn$, when Rn is 0, $1 \rightarrow T$ When Rn is nonzero, $0 \rightarrow T$	1	Comparison result
EXTS.B Rm, Rn	0110nnnnmmmm1110	A byte in Rm is sign-extended $\rightarrow Rn$	1	—
EXTS.W Rm, Rn	0110nnnnmmmm1111	A word in Rm is sign-extended $\rightarrow Rn$	1	—
EXTU.B Rm, Rn	0110nnnnmmmm1100	A byte in Rm is zero-extended $\rightarrow Rn$	1	—
EXTU.W Rm, Rn	0110nnnnmmmm1101	A word in Rm is zero-extended $\rightarrow Rn$	1	—
MAC.L @Rm+, @Rn+	0000nnnnmmmm1111	Signed operation of $(Rn) \times (Rm) \rightarrow$ MAC \rightarrow MAC $32 \times 32 \rightarrow 64$ bits	3/(2 to 4)*	—
MAC @Rm+, @Rn+	0100nnnnmmmm1111	Signed operation of $(Rn) \times (Rm) +$ MAC \rightarrow MAC $16 \times 16 + 64 \rightarrow 64$ bits	3/(2)*	—
MUL.L Rm, Rn	0000nnnnmmmm0111	$Rn \times Rm \rightarrow$ MACL, $32 \times 32 \rightarrow 32$ bits	2 to 4*	—
MULS.W Rm, Rn	0010nnnnmmmm1111	Signed operation of $Rn \times Rm \rightarrow$ MAC $16 \times 16 \rightarrow 32$ bits	1 to 3*	—
MULU.W Rm, Rn	0010nnnnmmmm1110	Unsigned operation of $Rn \times Rm \rightarrow$ MAC $16 \times 16 \rightarrow 32$ bits	1 to 3*	—
NEG Rm, Rn	0110nnnnmmmm1011	$0 - Rm \rightarrow Rn$	1	—
NEGC Rm, Rn	0110nnnnmmmm1010	$0 - Rm - T \rightarrow Rn$, Borrow $\rightarrow T$	1	Borrow

Table 2.13 Arithmetic Instructions (cont)

Instruction		Instruction Code	Operation	Execution States	T Bit
SUB	Rm, Rn	0011nnnnmmmm1000	Rn-Rm → Rn	1	—
SUBC	Rm, Rn	0011nnnnmmmm1010	Rn-Rm-T → Rn, Borrow → T	1	Borrow
SUBV	Rm, Rn	0011nnnnmmmm1011	Rn-Rm → Rn, Underflow → T	1	Underflow

Note: The normal minimum number of execution cycles. (The number in parentheses is the number of cycles when there is contention with preceding or following instructions.)

Table 2.14 Logic Operation Instructions

Instruction		Instruction Code	Operation	Execution States	T Bit
AND	Rm, Rn	0010nnnnmmmm1001	Rn & Rm → Rn	1	—
AND	#imm, R0	11001001iiiiiiii	R0 & imm → R0	1	—
AND.B	#imm, @(R0, GBR)	11001101iiiiiiii	(R0 + GBR) & imm → (R0 + GBR)	3	—
NOT	Rm, Rn	0110nnnnmmmm0111	~Rm → Rn	1	—
OR	Rm, Rn	0010nnnnmmmm1011	Rn Rm → Rn	1	—
OR	#imm, R0	11001011iiiiiiii	R0 imm → R0	1	—
OR.B	#imm, @(R0, GBR)	11001111iiiiiiii	(R0 + GBR) imm → (R0 + GBR)	3	—
TAS.B	@Rn	0100nnnn00011011	If (Rn) is 0, 1 → T; 1 → MSB of (Rn)	4	Test result
TST	Rm, Rn	0010nnnnmmmm1000	Rn & Rm; if the result is 0, 1 → T	1	Test result
TST	#imm, R0	11001000iiiiiiii	R0 & imm; if the result is 0, 1 → T	1	Test result
TST.B	#imm, @(R0, GBR)	11001100iiiiiiii	(R0 + GBR) & imm; if the result is 0, 1 → T	3	Test result
XOR	Rm, Rn	0010nnnnmmmm1010	Rn ^ Rm → Rn	1	—
XOR	#imm, R0	11001010iiiiiiii	R0 ^ imm → R0	1	—
XOR.B	#imm, @(R0, GBR)	11001110iiiiiiii	(R0 + GBR) ^ imm → (R0 + GBR)	3	—

Table 2.15 Shift Instructions

Instruction		Instruction Code	Operation	Execution States	T Bit
ROTL	Rn	0100nnnn00000100	$T \leftarrow Rn \leftarrow MSB$	1	MSB
ROTR	Rn	0100nnnn00000101	$LSB \rightarrow Rn \rightarrow T$	1	LSB
ROTCL	Rn	0100nnnn00100100	$T \leftarrow Rn \leftarrow T$	1	MSB
ROTCR	Rn	0100nnnn00100101	$T \rightarrow Rn \rightarrow T$	1	LSB
SHAL	Rn	0100nnnn00100000	$T \leftarrow Rn \leftarrow 0$	1	MSB
SHAR	Rn	0100nnnn00100001	$MSB \rightarrow Rn \rightarrow T$	1	LSB
SHLL	Rn	0100nnnn00000000	$T \leftarrow Rn \leftarrow 0$	1	MSB
SHLR	Rn	0100nnnn00000001	$0 \rightarrow Rn \rightarrow T$	1	LSB
SHLL2	Rn	0100nnnn00001000	$Rn \ll 2 \rightarrow Rn$	1	—
SHLR2	Rn	0100nnnn00001001	$Rn \gg 2 \rightarrow Rn$	1	—
SHLL8	Rn	0100nnnn00011000	$Rn \ll 8 \rightarrow Rn$	1	—
SHLR8	Rn	0100nnnn00011001	$Rn \gg 8 \rightarrow Rn$	1	—
SHLL16	Rn	0100nnnn00101000	$Rn \ll 16 \rightarrow Rn$	1	—
SHLR16	Rn	0100nnnn00101001	$Rn \gg 16 \rightarrow Rn$	1	—

DataSheet4U.com

Table 2.16 Branch Instructions

Instruction	Instruction Code	Operation	Execution States	T Bit
BF	label 10001011dddddddd	If T = 0, disp × 2 + PC → PC; if T = 1, nop	3/1*	—
BF/S	label 10001111dddddddd	Delayed branch, if T = 0, disp × 2 + PC → PC; if T = 1, nop	2/1*	—
BT	label 10001001dddddddd	Delayed branch, if T = 1, disp × 2 + PC → PC; if T = 0, nop	3/1*	—
BT/S	label 10001101dddddddd	If T = 1, disp × 2 + PC → PC; if T = 0, nop	2/1*	—
BRA	label 1010dddddddddddd	Delayed branch, disp × 2 + PC → PC	2	—
BRAF	Rm 0000mmmm00100011	Delayed branch, Rm + PC → PC	2	—
BSR	label 1011dddddddddddd	Delayed branch, PC → PR, disp × 2 + PC → PC	2	—
BSRF	Rm 0000mmmm00000011	Delayed branch, PC → PR, Rm + PC → PC	2	—
JMP	@Rm 0100mmmm00101011	Delayed branch, Rm → PC	2	—
JSR	@Rm 0100mmmm00001011	Delayed branch, PC → PR, Rm → PC	2	—
RTS	0000000000001011	Delayed branch, PR → PC	2	—

Note: One state when the instruction does not branch.

Table 2.17 System Control Instructions

Instruction	Instruction Code	Operation	Execution States	T Bit
CLRT	0000000000001000	0 → T	1	0
CLRMACH	0000000000101000	0 → MACH, MACL	1	—
LDC Rm, SR	0100mmmm00001110	Rm → SR	1	LSB
LDC Rm, GBR	0100mmmm00011110	Rm → GBR	1	—
LDC Rm, VBR	0100mmmm00101110	Rm → VBR	1	—
LDC.L @Rm+, SR	0100mmmm00000111	(Rm) → SR, Rm + 4 → Rm	3	LSB
LDC.L @Rm+, GBR	0100mmmm00010111	(Rm) → GBR, Rm + 4 → Rm	3	—
LDC.L @Rm+, VBR	0100mmmm00100111	(Rm) → VBR, Rm + 4 → Rm	3	—
LDS Rm, MACH	0100mmmm00001010	Rm → MACH	1	—
LDS Rm, MACL	0100mmmm00011010	Rm → MACL	1	—
LDS Rm, PR	0100mmmm00101010	Rm → PR	1	—
LDS.L @Rm+, MACH	0100mmmm00000110	(Rm) → MACH, Rm + 4 → Rm	1	—
LDS.L @Rm+, MACL	0100mmmm00010110	(Rm) → MACL, Rm + 4 → Rm	1	—
LDS.L @Rm+, PR	0100mmmm00100110	(Rm) → PR, Rm + 4 → Rm	1	—
NOP	0000000000010010	No operation	1	—
RTE	0000000000101011	Delayed branch, stack area → PC/SR	4	—
SETT	000000000011000	1 → T	1	1
SLEEP	000000000011011	Sleep	3*	—
STC SR, Rn	0000nnnn00000010	SR → Rn	1	—
STC GBR, Rn	0000nnnn00010010	GBR → Rn	1	—
STC VBR, Rn	0000nnnn00100010	VBR → Rn	1	—
STC.L SR, @-Rn	0100nnnn00000011	Rn-4 → Rn, SR → (Rn)	2	—
STC.L GBR, @-Rn	0100nnnn00010011	Rn-4 → Rn, GBR → (Rn)	2	—
STC.L VBR, @-Rn	0100nnnn00100011	Rn-4 → Rn, VBR → (Rn)	2	—

Table 2.17 System Control Instructions (cont)

Instruction		Instruction Code	Operation	Execution States	T Bit
STS	MACH, Rn	0000nnnn00001010	MACH → Rn	1	—
STS	MACL, Rn	0000nnnn00011010	MACL → Rn	1	—
STS	PR, Rn	0000nnnn00101010	PR → Rn	1	—
STS.L	MACH, @-Rn	0100nnnn00000010	Rn-4 → Rn, MACH → (Rn)	1	—
STS.L	MACL, @-Rn	0100nnnn00010010	Rn-4 → Rn, MACL → (Rn)	1	—
STS.L	PR, @-Rn	0100nnnn00100010	Rn-4 → Rn, PR → (Rn)	1	—
TRAPA	#imm	11000011iiiiiiii	PC/SR → stack area, (imm) → PC	8	—

Note: The number of execution states before the chip enters the sleep mode.

Instruction states: The values shown for the execution states are minimums. The actual number of states may be increased when:

- Contention occurs between instruction fetch and data access
- The destination register of the load instruction (memory → register) and the register used by the next instruction are the same.

DataSheet4U.com

et4U.com

DataShee

DataSheet4U.com

www.DataSheet4U.com

DataSheet4U.com

Table 2.18 Operation Code Map

Instruction Code				Fx: 0000	Fx: 0001	Fx: 0010	Fx: 0011-1111
MSB		LSB		MD: 00	MD: 01	MD: 10	MD: 11
0000	Rn	Fx	0000				
0000	Rn	Fx	0001				
0000	Rn	Fx	0010	STC SR, Rn	STC GBR, Rn	STC VBR, Rn	
0000	Rm	Fx	0011	BSRF Rm		BRAF Rm	
0000	Rn	Rm	01MD	MOV.B RM, @(R0, Rn)	MOV.W RM, @(R0, Rn)	MOV.L RM, @(R0, Rn)	MUL.L Rm, Rn
0000	0000	Fx	1000	CLRT	SETT	CLRMAC	
0000	0000	Fx	1001	NOP	DIVOU		
0000	0000	Fx	1010				
0000	0000	Fx	1011	RTS	SLEEP	RTE	
0000	Rn	Fx	1000				
0000	Rn	Fx	1001			MOVT Rn	
0000	Rn	Fx	1010	STS MACH, Rn	STS MACL, Rn	STS PR, Rn	
0000	Rn	Fx	1011				
0000	Rn	Rm	11MD	MOV.B @(R0, Rm), Rn	MOV.W @(R0, Rm), Rn	MOV.L @(R0, Rm), Rn	MAC.L @Rm+, @Rn+
0001	Rn	Rm	disp	MOV.L Rm, @(disp:4, Rn)			
0010	Rn	Rm	00MD	MOV.B Rm, @Rn	MOV.W Rm, @Rn	MOV.L Rm, @Rn	
0010	Rn	Rm	01MD	MOV.B Rm, @-Rn	MOV.W Rm, @-Rn	MOV.L Rm, @-Rn	DIV0S Rm, Rn
0010	Rn	Rm	10MD	TST Rm, Rn	AND Rm, Rn	XOR Rm, Rn	OR Rm, Rn
0010	Rn	Rm	11MD	CMP/STR Rm, Rn	XTRCT Rm, Rn	MULU.W Rm, Rn	MULS.W Rm, Rn
0011	Rn	Rm	00MD	CMP/EQ Rm, Rn		CMP/HS Rm, Rn	CMP/GE Rm, Rn
0011	Rn	Rm	01MD	DIV1 Rm, Rn	DMULU.L Rm, Rn	CMP/HI Rm, Rn	CMP/GT Rm, Rn
0011	Rn	Rm	10MD	SUB Rm, Rn		SUBC Rm, Rn	SUBV Rm, Rn
0011	Rn	Rm	11MD	ADD Rm, Rn	DMULS.L Rm, Rn	ADDC Rm, Rn	ADDV Rm, Rn
0100	Rn	Fx	0000	SHLL Rn	DT Rn	SHAL Rn	

Table 2.18 Operation Code Map (cont)

Instruction Code				Fx: 0000	Fx: 0001	Fx: 0010	Fx: 0011-1111	
MSB		LSB		MD: 00	MD: 01	MD: 10	MD: 11	
0100	Rn	Fx	0001	SHLR Rn	CMP/PZ Rn	SHAR Rn		
0100	Rn	Fx	0010	STS.L MACH, @-Rn	STS.L MACL, @-Rn	STS.L PR, @-Rn		
0100	Rn	Fx	0011	STC.L SR,@-Rn	STC.L GBR,@-Rn	STC.L VBR,@-Rn		
0100	Rn	Fx	0100	ROTL Rn		ROTCL Rn		
0100	Rn	Fx	0101	ROTR Rn	CMP/PL Rn	ROTCR Rn		
0100	Rm	Fx	0110	LDS.L @Rm+,MACH	LDS.L @Rm+,MACL	LDS.L @Rm+,PR		
0100	Rm	Fx	0111	LDC.L @Rm+,SR	LDC.L @Rm+,GBR	LDC.L @Rm+,VBR		
0100	Rn	Fx	1000	SHLL2 Rn	SHLL8 Rn	SHLL16 Rn		
0100	Rn	Fx	1001	SHLR2 Rn	SHLR8 Rn	SHLR16 Rn		
0100	Rm	Fx	1010	LDS Rm,MACH	LDS Rm,MACL	LDS Rm,PR		
0100	Rm/Rn	Fx	1011	JSR @Rm	TAS.B @Rn	JMP @Rm		
0100	Rm	Fx	1100					
0100	Rm	Fx	1101					
0100	Rm	Fx	1110	LDC Rm,SR	LDC Rm,GBR	LDC Rm,VBR		
0100	Rn	Rm	1111	MAC.W @Rm+,@Rn+				
0101	Rn	Rm	disp	MOV.L @(disp:4,Rm),Rn				
0110	Rn	Rm	00MD	MOV.B @Rm,Rn	MOV.W @Rm,Rn	MOV.L @Rm,Rn	MOV Rm,Rn	
0110	Rn	Rm	01MD	MOV.B @Rm+,Rn	MOV.W @Rm+,Rn	MOV.L @Rm+,Rn	NOT Rm,Rn	
0110	Rn	Rm	10MD	SWAP.B Rm,Rn	SWAP.W Rm,Rn	NEGC Rm,Rn	NEG Rm,Rn	
0110	Rn	Rm	11MD	EXTU.B Rm,Rn	EXTU.W Rm,Rn	EXTS.B Rm,Rn	EXTS.W Rm,Rn	
0111	Rn	imm		ADD #imm:8,Rn				
1000	00MD	Rn	disp	MOV.B R0, @(disp:4,Rn)	MOV.W R0, @(disp:4,Rn)			
1000	01MD	Rm	disp	MOV.B @(disp:4, Rm),R0	MOV.W @(disp:4, Rm),R0			

Table 2.18 Operation Code Map (cont)

Instruction Code			Fx: 0000	Fx: 0001	Fx: 0010	Fx: 0011–1111
MSB	LSB		MD: 00	MD: 01	MD: 10	MD: 11
1000	10MD	imm/disp	CMP/EQ #imm:8,R0	BT label:8		BF label:8
1000	10MD	imm/disp		BT/S label:8		BF/S label:8
1001	Rn	disp	MOV.W @(disp:8,PC),Rn			
1010		disp	BRA label:12			
1011		disp	BSR label:12			
1100	00MD	imm/disp	MOV.B R0, @(disp:8, GBR)	MOV.W R0, @(disp:8, GBR)	MOV.L R0, @(disp:8, GBR)	TRAPA #imm:8
1100	01MD	disp	MOV.B @(disp:8, GBR),R0	MOV.W @(disp:8, GBR),R0	MOV.L @(disp:8, GBR),R0	MOVA @(disp:8, PC),R0
1100	10MD	imm	TST #imm:8,R0	AND #imm:8,R0	XOR #imm:8,R0	OR #imm:8,R0
1100	11MD	imm	TST.B #imm:8, @(R0,GBR)	AND.B #imm:8, @(R0,GBR)	XOR.B #imm:8, @(R0,GBR)	OR.B #imm:8, @(R0,GBR)
1101	Rn	disp	MOV.L @(disp:8,PC),Rn			
1110	Rn	imm	MOV #imm:8,Rn			
1111		...				

2.5 Processing States

2.5.1 State Transitions

The CPU has five processing states: reset, exception handling, bus-released, program execution, and power-down. Figure 2.6 shows the transitions between the states. See section 14, Power-Down State, for more information on the power-down state.

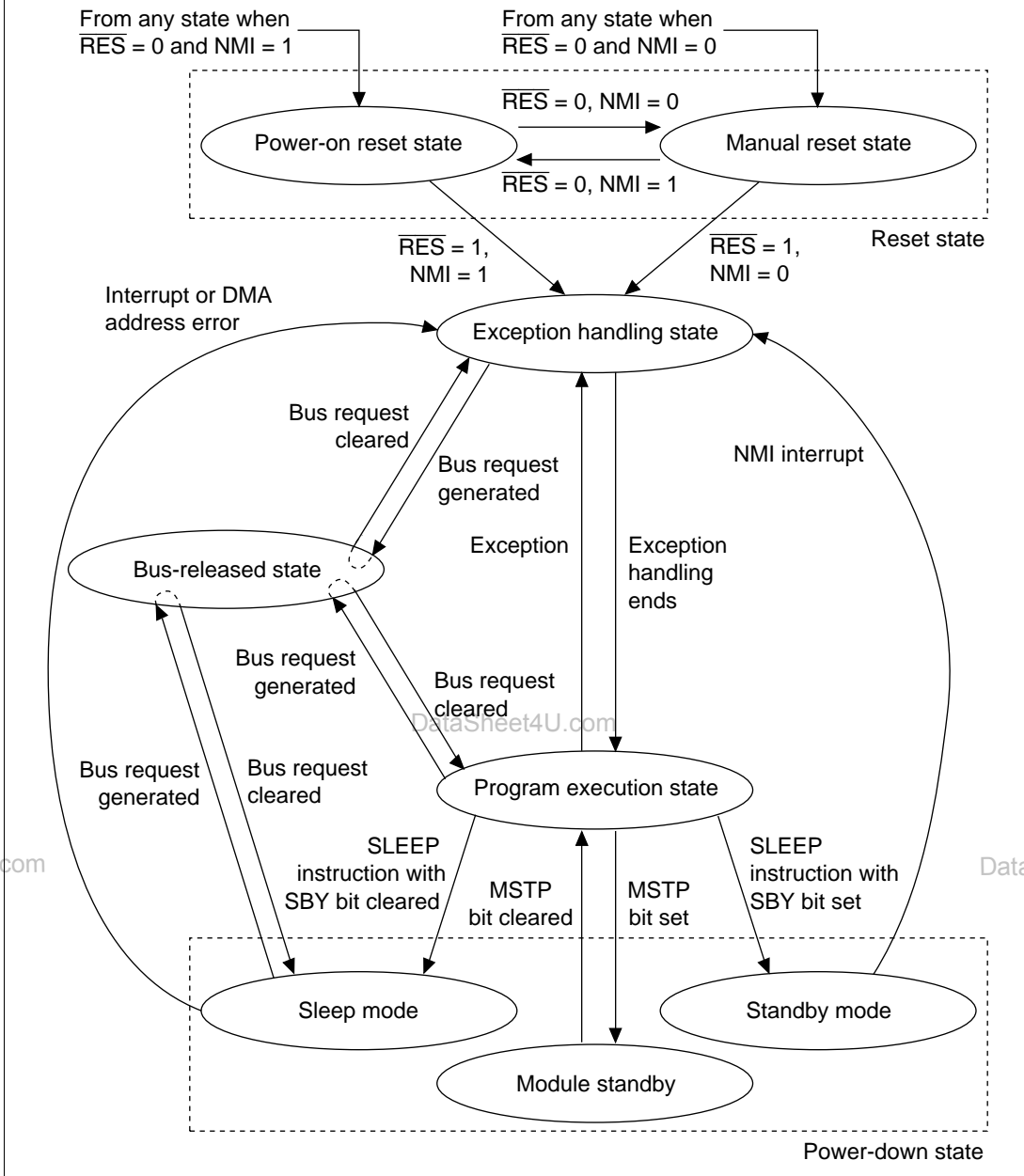

Figure 2.6 Transitions between Processing States

Reset State: The CPU resets in the reset state. This occurs when the $\overline{\text{RES}}$ pin level goes low. When the NMI pin is high, the result is a power-on reset; when it is low, a manual reset will occur.

Exception Handling State: The exception handling state is a transient state that occurs when an exception handling source such as a reset or interrupt alters the CPU's processing state flow.

For a reset, the initial values of the program counter (PC) (execution start address) and stack pointer (SP) are fetched from the exception vector table and stored; the CPU then branches to the execution start address and execution of the program begins.

For an interrupt, the stack pointer (SP) is accessed and the program counter (PC) and status register (SR) are saved to the stack area. The exception service routine start address is fetched from the exception processing vector table; the CPU then branches to that address and the program starts executing, thereby entering the program execution state.

Program Execution State: In the program execution state, the CPU sequentially executes the program.

Power-Down State: In the power-down state, the CPU operation halts and power consumption declines. The SLEEP instruction places the CPU in the power-down state. This state has two modes: sleep mode and standby mode. See section 2.5.2 for more details.

Bus-Released State: In the bus-released state, the CPU releases the bus to the device that has requested it.

DataSheet4U.com

2.5.2 Power-Down State

Besides the ordinary program execution states, the CPU also has a power-down state in which CPU operation halts, lowering power consumption (table 2.19). There are two power-down state modes, sleep mode and standby mode, and also a module standby function.

Sleep Mode: When standby bit SBY (in the standby control register SBYCR) is cleared to 0 and a SLEEP instruction executed, the CPU moves from program execution state to sleep mode. The on-chip peripheral modules other than the CPU do not halt in the sleep mode. To return from sleep mode, use a reset, any interrupt, or a DMA address error; the CPU returns to the ordinary program execution state through the exception handling state.

Software Standby Mode: To enter the standby mode, set the standby bit SBY (in the standby control register SBYCR) to 1 and execute a SLEEP instruction. In standby mode, all CPU, on-chip peripheral module, and oscillator functions are halted. When entering the standby mode, confirm that the DMAC master enable bit is 0. If a multiply instruction is in progress on entry to standby mode, the MACL and MACH registers will be invalid. CPU internal register contents and on-chip RAM data are retained. Cache (and on-chip RAM) data is not retained.

www.DataSheet4U.com

To return from standby mode, use a reset or an external NMI interrupt. For resets, the CPU returns to the ordinary program execution state through the exception handling state when placed in a reset state after the oscillator stabilization time has elapsed. For NMI interrupts, the CPU returns to the ordinary program execution state through the exception handling state after the oscillator stabilization time has elapsed. Turn the cache off before entering standby mode. In this mode, power consumption drops substantially because the oscillator stops.

Module Standby Function: The module standby function is available for the multiplier (MULT), divider (DIVU), 16-bit free-running timer (FRT), serial communication interface (SCI), and DMA controller (DMAC) on-chip peripheral modules.

The supply of the clock to these on-chip peripheral modules can be halted by setting the corresponding bits 4–0 (MSTP4–MSTP0) in the standby control register (SBYCR). By using this function, the power consumption can be reduced.

The external pins of the on-chip peripheral modules in module standby mode are reset and all registers except DMAC, MULT, and DIVU are initialized. The module standby function is cleared by clearing the MSTP4–MSTP0 bits to 0.

When MULT has entered the software standby mode, do not execute the DMULS.L, DMULU.L, MAC.L, MAC.W, MUL.L, MULS, and MULU instructions (all of which are multiply instructions) or any instructions that access the MACH and MACL registers (CLRMAC, LDS MACH/MACL, STS MACH/MACL).

DataSheet4U.com

When the DMAC module standby function is used, set the DMAC's DMA master enable bit to 0.

Table 2.19 Power-Down State

Mode	Conditions	State					Canceling
		Clock	CPU	On-Chip Peripheral Modules	CPU Registers	RAM	
Sleep	Execute SLEEP instruction with SBY bit cleared to 0 in SBYCR	Active	Halted	Active	Held	Held	<ol style="list-style-type: none"> 1. Interrupt 2. DMA address error 3. Power-on reset 4. Manual reset
Standby	Execute SLEEP instruction with SBY bit set to 1 in SBYCR	Halted	Halted	Halted and initialized ^{*1}	Held	Undefined	<ol style="list-style-type: none"> 1. NMI 2. Power-on reset 3. Manual reset
Module standby	MSTP4–MSTP0 bits of SBYCR set to 1	Active	Active (MULT is halted.)	Supply of clock to affected module is halted and module initialized. ^{*2}	Held	Held	Clear bits MSTP 4–0 of SBYCR to 0

Notes: 1. Depends on peripheral module and pin.

2. The DMAC, MULT, and DIV registers and the specified interrupt vectors retain their settings.

Section 3 Oscillator Circuits and Operating Modes

3.1 Overview

Operation of the on-chip clock pulse generator, CS0 area bus width specification, and switching between master and slave modes are controlled by the operating mode pins. A crystal resonator or external clock can be selected as the clock source.

3.2 On-Chip Clock Pulse Generator and Operating Modes

3.2.1 Clock Pulse Generator

A block diagram of the on-chip clock pulse generator circuit is shown in figure 3.1.

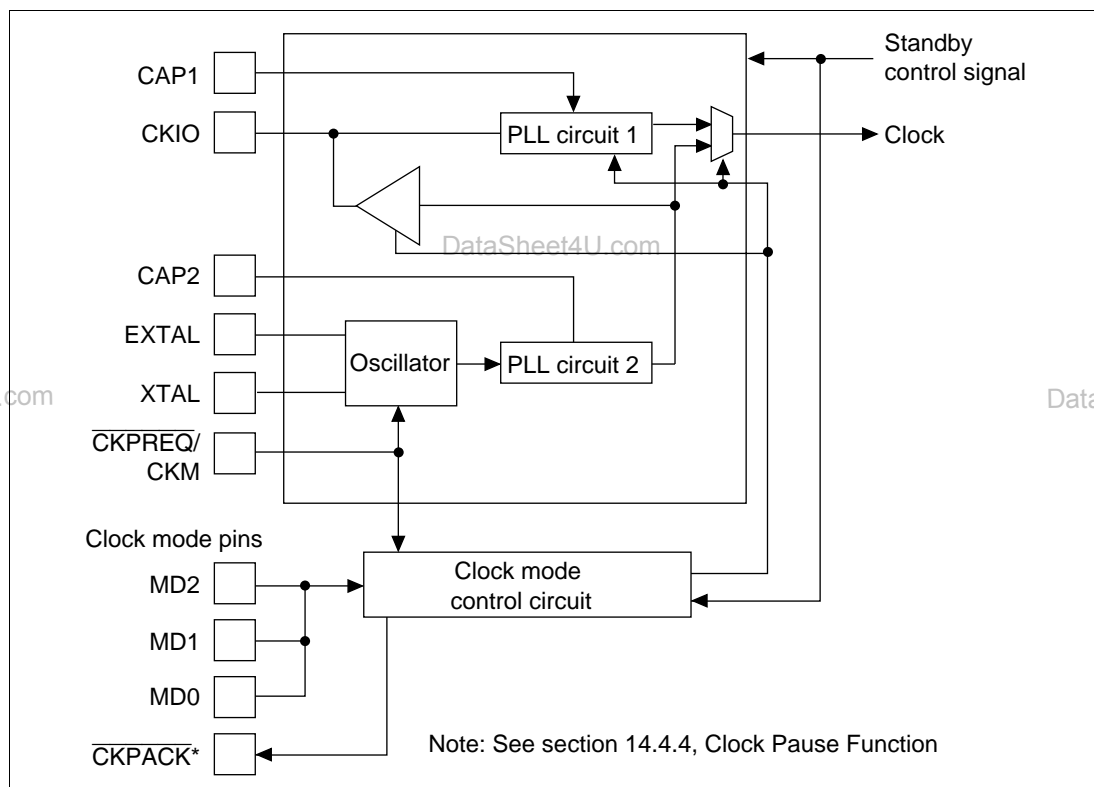

Figure 3.1 Block Diagram of Clock Pulse Generator Circuit

Pin Configuration: Table 3.1 lists the functions relating to the pins relating to the oscillator circuit.

Table 3.1 Pin Functions

Pin Name	I/O	Function
CKIO	I/O	External clock input pin or internal clock output pin
XTAL	O	Connects to the crystal resonator.
EXTAL	I	Connects to the crystal resonator or to the external clock input when using PLL circuit 2.
CAP1	I	Connects to capacitance for operating PLL circuit 1.
CAP2	I	Connects to capacitance for operating PLL circuit 2.
MD0	I	The level applied to these pins specifies the clock mode.
MD1	I	
MD2	I	
CKPREQ/CKM	I	Used as the clock pause request pin, or specifies operation of the crystal oscillator.

PLL Circuit 1: PLL circuit 1 eliminates phase differences between external clocks and clocks supplied internally within the chip. In high-speed operation, the phase difference between the reference clocks and operating clocks in the chip directly affects the interface margin with peripheral devices. On-chip PLL circuit 1 is provided to eliminate this effect.

PLL circuit 1 can also make the phase difference between the clocks 90 degrees, enabling high-speed interface with synchronous DRAM.

PLL Circuit 2: PLL circuit 2 either leaves unchanged, doubles, or quadruples the frequency of clocks provided from the crystal resonator or the EXTAL pin external clock input for the chip operating frequency. The frequency modification register sets the clock frequency multiplication factor.

3.2.2 Clock Operating Mode Settings

Table 3.2 lists the functions and operation of clock modes 0 to 6.

Note that TBP-176 package products can only be used in clock modes 4 to 6.

Table 3.2 Operating Modes

Clock Mode	Function/Operation	Clock Source
0	PLL circuits 1 and 2 operate. A clock with the same phase as the internal chip clock is output from the CKIO pin.	Crystal resonator/ External clock input
1	PLL circuits 1 and 2 operate. A clock shifted 90° from the CKIO pin output is supplied to the internal chip clock.	Crystal resonator/ External clock input
2	Only PLL circuit 2 operates. The clock from PLL circuit 2 is output from the CKIO pin. Phases are not matched in this mode.	Crystal resonator/ External clock input
3	Only PLL circuit 2 operates. The CKIO pin is high impedance. Phases are not matched in this mode.	Crystal resonator/ External clock input
4	Set this mode when the CKIO pin inputs a clock having a frequency equivalent to the object operating frequency and PLL circuit 1 synchronizes the phases of the input clock and the internal clock.	External clock input
5	Set this mode when the CKIO pin inputs a clock having a frequency equivalent to the object operating frequency and PLL circuit 1 shifts the phases of the input clock and internal clock by 90 degrees.	External clock input
6	Set this mode when a clock having a frequency equivalent to that of clocks input from the CKIO pin are used. PLL circuits 1 and 2 do not operate.	External clock input

When clock modes 0 to 3 are selected, the input frequency or its double or quadruple (produced by PLL circuit 2) is used as the internal clock. When clock modes 4 to 6 are selected, the clock pause function can modify the frequency of clocks input from the CKIO pin or can stop the sending of clock signals (see section 14.4, Standby Mode). When clock modes 4 to 6 are set, PLL circuit 2 stops.

Table 3.3 lists the relationship between pins MD2 to MD0 and the clock operating mode. Do not switch the MD2–MD0 pins while they are operating. Switching will cause operating errors.

Table 3.3 Clock Mode Pin Settings and States

Clock Mode	Pin*1							
	MD2	MD1	MD0	CKPREQ/ CKM	EXTAL	XTAL	CKIO	Internal Clock
0	0	0	0	0 1	Clock input Crystal oscillation	Open Crystal oscillation	Output	Synchronized to a phase difference of 0° from CKIO by PLL circuit 1
1	0	0	1	0 1	Clock input Crystal oscillation	Open Crystal oscillation	Output	Synchronized to a phase difference of 90° from CKIO by PLL circuit 1
2	0	1	0	0 1	Clock input Crystal oscillation	Open Crystal oscillation	Output	CKIO
3	0	1	1	0 1	Clock input Crystal oscillation	Open Crystal oscillation	High impedance	PLL circuit 2 output
4	1	0	0	*2	Open	Open	Clock input	Synchronized to a phase difference of 0° from CKIO by PLL circuit 1
5	1	0	1		Open	Open	Clock input	Synchronized to a phase difference of 90° from CKIO by PLL circuit 1
6	1	1	0		Open	Open	Clock input	CKIO

Notes: 1. Do not use in combinations other than those listed.

2. In clock modes 4, 5, and 6, $\overline{\text{CKPREQ}}$ /CKM functions as the clock pause request pin.

3. For TBP-176 package products, only clock mode 4, 5, or 6 can be selected.

3.2.3 Connecting a Crystal Resonator

Connecting a Crystal Resonator: Figure 3.2 shows how to connect a crystal resonator. Use the value shown in table 3.4 for the damping resistance R_d . The crystal resonator should be an AT-cut parallel-resonance type. Be sure to connect load capacitors (CL1, CL2) as shown in the figure.

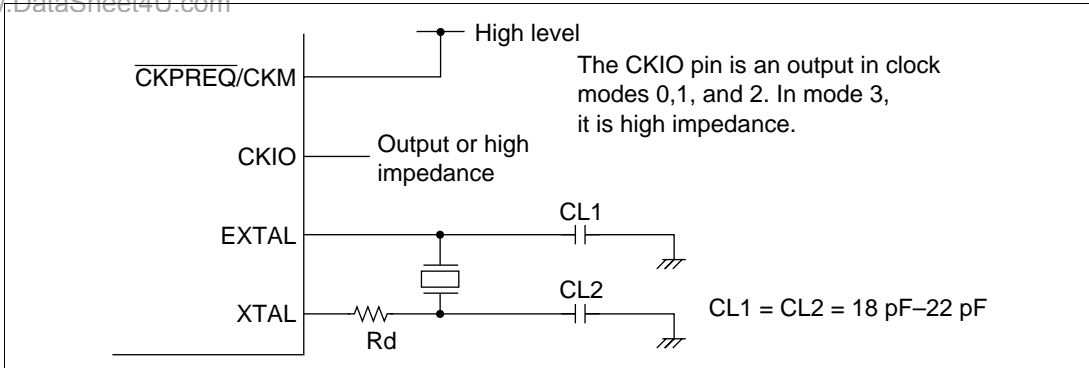

Figure 3.2 Example of Crystal Resonator Connection

Table 3.4 Damping Resistance (Reference Values)

Frequency (MHz)	4	6	8
Rd (Ω)	500	200	0

Crystal Resonator: Figure 3.3 shows a crystal resonator equivalent circuit. Use a crystal resonator that has the characteristics shown in table 3.5.

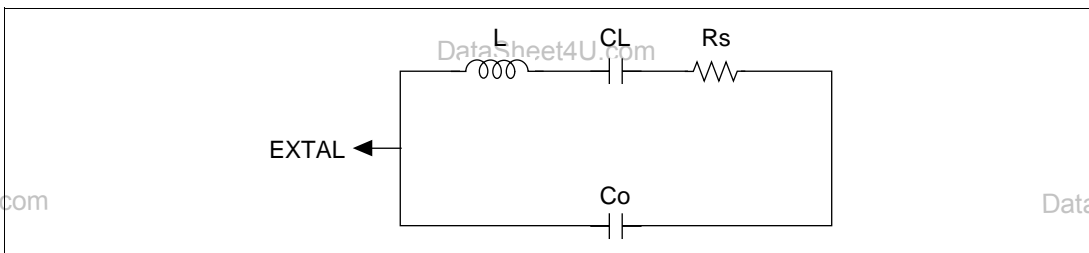

Figure 3.3 Crystal Resonator Equivalent Circuit

Table 3.5 Crystal Resonator Characteristics (Reference Values)

Parameters	Frequency (MHz)		
	4	6	8
Rs max (Ω)	120	100	80
Co max (pF)	7 pF max		

3.2.4 Inputting an External Clock

Input the external clock from the EXTAL pin or the CKIO pin, depending on the clock mode.

Clock Input from the EXTAL Pin: This can be used in clock modes 0,1, 2, and 3.

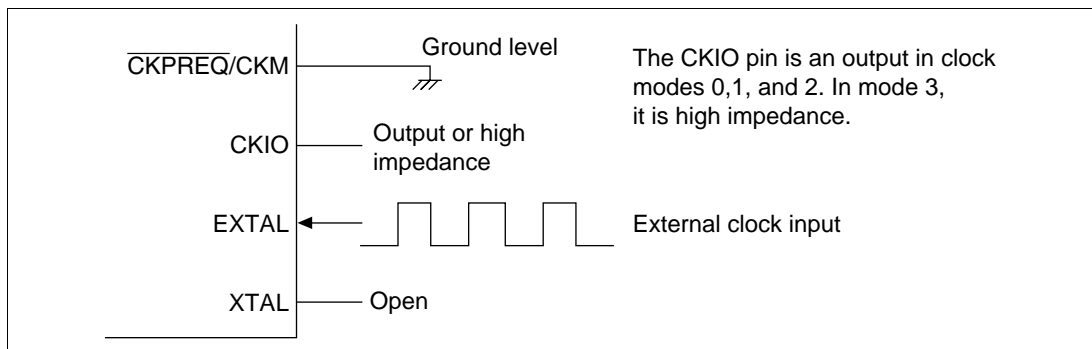

Figure 3.4 Inputting External Clock

Clock Input from the CKIO Pin: This can be used in clock modes 4, 5, and 6.

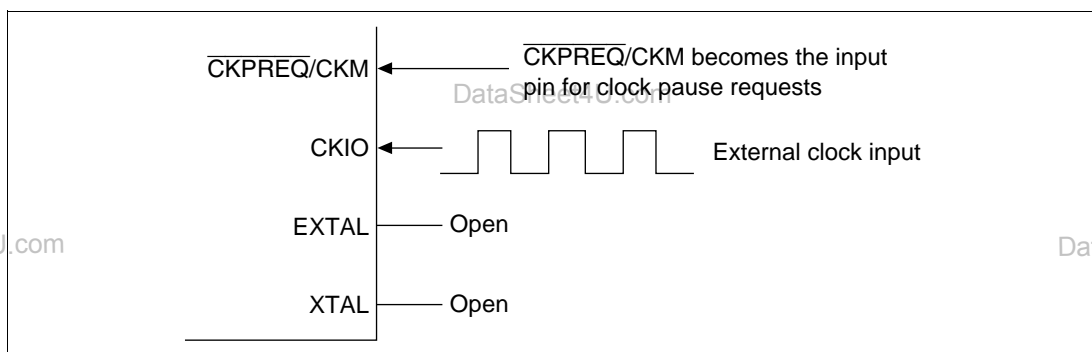

Figure 3.5 Inputting External Clock

3.2.5 Selecting Operating Frequency with a Register

PLL circuit 2 and the frequency modification register can double or quadruple the operating frequency in clock modes 0 to 3. Figure 3.6 shows a block diagram of PLL circuit 2 and the frequency modification register.

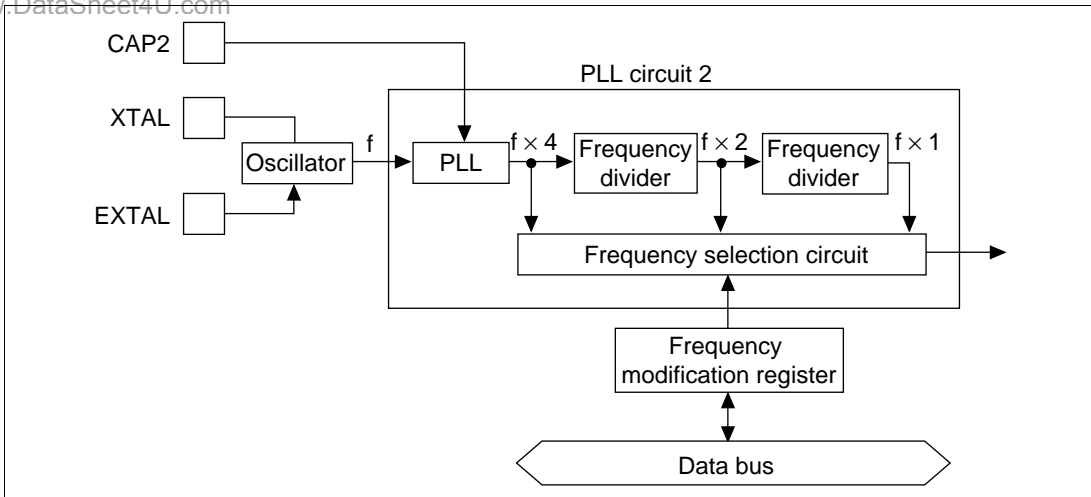

Figure 3.6 Relationship between PLL Circuit 2 and the Frequency Modification Register

PLL circuit 2 includes the PLL circuit (which quadruples frequency f of clocks generated by the oscillator) and frequency dividers, which divide the output of the PLL circuit by 2 or 4. The clocks ($f \times 1$, $f \times 2$, and $f \times 4$) are input to the frequency selection circuit, where one is selected according to the value set in the frequency modification register, and is then output from PLL circuit 2.

Frequency Modification Register: This register is only initialized by a power-on reset. It holds its values in a manual reset and in standby mode. Table 3.6 shows the register configuration, and the following figure shows the bit combinations and functions.

Table 3.6 Frequency Modification Register

Register	Abbrev.	R/W	Initial Value	Address	Access Size
Frequency modification register	FMR	R/W	H'00	H'FFFFFFE90	8

Bit:	7	6	5	4	3	2	1	0
Bit name:	—	—	—	—	—	—	FR1	FR0
Initial value:	0	0	0	0	0	0	0	0
R/W:	R	R	R	R	R	R	R/W	R/W

Bit 1: FR1	Bit 0: FR0	Description
0	0	No multiplication (Initial value)
	1	$\times 2$ multiplication
1	0	$\times 4$ multiplication
	1	Setting prohibited

Bits 2–7 are reserved. They always read 0, and the write value should always be 0.

Modifying Frequencies: In the following modifications, the device is running in clock modes 0 to 3, and the operating frequency is left unchanged, doubled, or quadrupled using PLL circuit 2.

- Set the TME bit to 0 in or above the oscillation settling time that specifies the on-chip WDT's overflow time.
- Set the frequency modification register to the target value. (The chip will go internally to standby mode temporarily.)
- All circuits involved in oscillation operate and the clock is supplied to the WDT. The WDT overflows with this clock.
- When the WDT overflows, a clock at the frequency set within the chip begins to be supplied and the chip returns from standby mode.

Frequency Modification Guidelines:

- Only write to the frequency modification register while the cache is disabled.
- The frequency modification program is always in cache memory and so should be executed utilizing the forced access space of the data array. Figure 3.7 shows how the frequency modification register is set.
- When the frequency modification program is executed, execute an associative or forced purge of the entries in the data array used.
- Place at least eight consecutive NOP instructions after an instruction that writes to the frequency modification register.

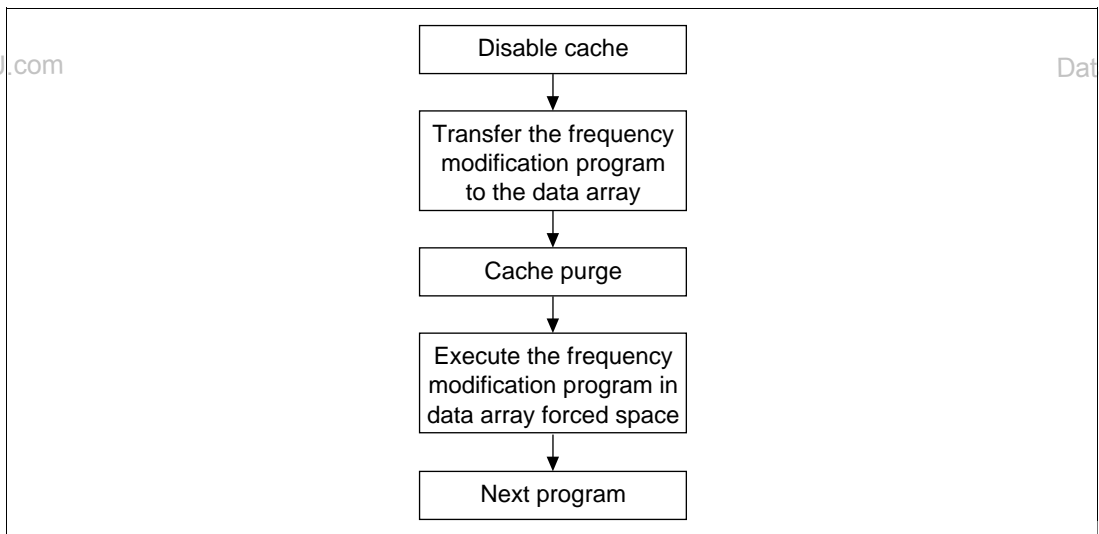

Figure 3.7 Frequency Modification Flowchart

Frequency Modification Register Setting Program (Sample)

```

; DEFINE CONSTANTS
CLR          .EQU          H'00000000
WAIT_TIME   .EQU          H'00080000
PURGE       .EQU          H'40000000
;
MAP_ROM     .EQU          H'00000000
MAP-IO      .EQU          H'FFFFFF00
;
DIRECT_RW   .EQU          H'C0000000
MDC_FLCR    .EQU          H'FFFFFFE90
MDC_CCR     .EQU          H'FFFFFFE92
WTCSR       .EQU          H'FFFFFFE80
;
; Program initialization
        MOV.L          #CLOCK2_START,R0
        MOV.L          #DIRECT_RW,R1
        MOV.L          #CLOCK2_END,R11
; Cache_CCR save, disable, and forced purge
        MOV.L          #MDC_CCR,R2
        MOV.B          @R2,R6
        MOV            #H'00,R3          ;Disable setting
        MOV.B          R3,@R2
        MOV.B          @R2,R3          ;Dummy read
        MOV            #H'10,R3          ;Forced purge setting
        MOV.B          R3,@R2
;
; Transfer frequency modification program to the data array
;
PRG_TRNS
; Read from the main memory
        MOV.L          @R0,R2
        MOV.L          @(4,R0),R3*11
        MOV.L          @(8,R0),R4*11
        MOV.L          @(12,R0),R5*11
; Write to the data array
        MOV.L          R2,@R1

```

```

MOV.L      R3,@(4,R1)*1
MOV.L      R4,@(8,R1)*1
MOV.L      R5,@(12,R1)*1

; Increment pointer
ADD        #H'10,R0
ADD        #H'10,R1

; Loop
CMP/GT     R11,R0
BF         PRG_TRNS

; Branch to the data array forced access space
MOV.L      #DIRECT_RW,R0
JMP        @R0
NOP
.CONST*2

;
CLOCK2_START
MOV.L      #NEXT_PROG,R3      ;Branch destination address
                                for the next program

MOV.L      #WTCSR,R0          ;WDT setting
MOV.L      #H'0000A507,R1    ;Set enough time for PLL to be
                                stabilized

MOV.W      R1,@R0

MOV.L      #MDC_FLCR,R2      ;Frequency modification
                                register setting
MOV        #H'01,R1          ;Double the internal frequency
MOV.B      R1,@R2

; Wait during frequency modification
NOP
NOP
NOP
NOP
NOP
NOP
NOP
NOP
NOP
NOP

```

```

NOP
NOP
NOP
NOP
NOP
NOP
NOP
NOP
; Branch to the next program
    JMP          @R3
NOP
    .CONST*2
CLOCK2_END

;
; Next program
NEXT_PROG

; Cache_CCR load
    MOV.L        #MDC_CCR,R2
    MOV.B        R6,@R2
    .
    .
    .

```

Notes: *1 This example shows Hitachi cross-assembler coding. With the Hitachi cross-assembler, the values to which scaling ($\times 1$, $\times 2$, $\times 4$) is applied are written. For coding in other cross-assemblers, see the notation rules.

*2 This is a literal pool output control statement. Code according to the notation rule for the assembler used. The Hitachi cross-assembler is not required.

*3 When the WTCSR set value is read, H'0000A51F' is returned.

3.2.6 Operating Modes and Frequency Ranges

Table 3.7 shows the operating modes and the associated frequency ranges for input clocks.

Table 3.7 Operating Modes and Frequency Ranges

Mode	PLL Circuit		Pin	Clock Input Input Frequency Range (MHz)	Internal Clock Frequency (MHz)	CKIO Output Frequency (MHz)	Comments
	PLL1	PLL2					
0	Active	Active	EXTAL (including when resonator is used)	4–8* ¹	4–max* ²	7–max* ²	Multiplication ratio settable (×1, ×2, ×4)
1							
2	Halted						
3							
4	Active	Halted	CKIO	7–max* ²	7–max* ³		Multiplication not settable (×1 only)
5							
6	Halted			4–max* ²	4–max* ²		

- Notes:
1. Make the setting so that the clock frequency output from the CKIO pin does not exceed the maximum operating frequency. For example, if 8 MHz is input, set the multiplication ratio of the frequency to ×1 or ×2. (If ×4 is used, a 32-MHz clock is output from the CKIO pin, which is outside the range for the PLL circuit 1 input frequency.)
 2. “max” represents the maximum operating frequency of 28.7 MHz at 5 V operation and 20.0 MHz at 3.3 V operation.
 3. If CKIO output below 7 MHz is used during PLL circuit 1 operation, AC characteristics using the CKIO output are not guaranteed.

3.2.7 Notes on Board Design

When Using a Crystal Resonator: Place the crystal resonator and capacitors as close to the EXTAL and XTAL pins as possible. Do not let the pins’ signal lines cross other signal lines. If they do, induction may prevent proper oscillation.

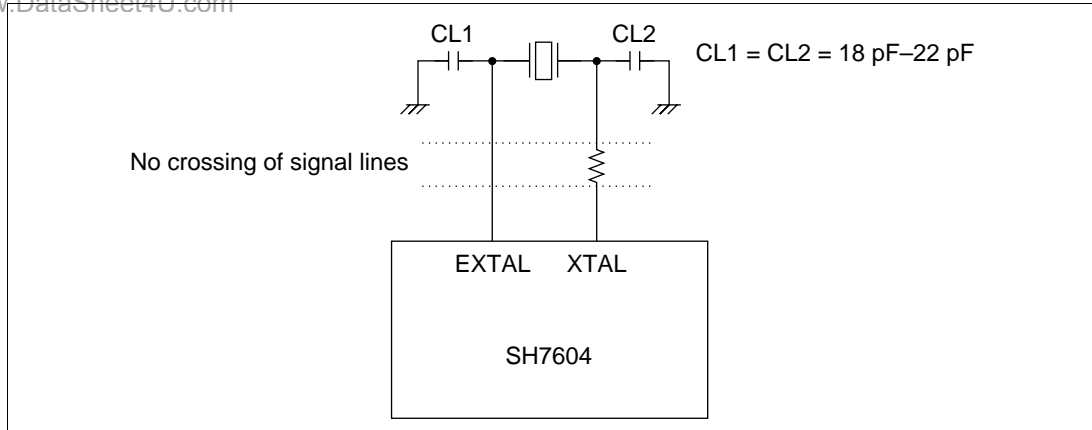

Figure 3.8 Design Considerations when Using a Crystal Resonator

When Using PLL Oscillation Circuits: Place oscillation settling capacitors C1 and C2 and resistors R1 and R2 near the CAP1 and CAP2 pins, and keep the wiring from the CAP pins as short as possible. As the CAP pin circuits are susceptible to influence by other signals, avoid crossing signal lines both on the board surface and in internal layers. PLL- V_{CC} and PLL- V_{SS} should be isolated from other V_{CC} and V_{SS} lines away from the board's power supply sources, and bypass capacitors CPB and CB must be inserted near the pins.

In the clock circuits in this product, clock stability may be affected by reflected noise generated by the CKIO pin. This influence is especially great in clock modes 0 and 1, in which the PLL1 and PLL2 circuits are used simultaneously, so the board design should ensure that reflected noise does not occur in CKIO. In clock mode 6, in which no PLLs are used, connect PLL- V_{CC} to V_{CC} and PLL- V_{SS} to V_{SS} .

Table 3.8 Connected Resistance and Capacitance Reference Values

Resistance/Capacitance	Mode Setting						
	0	1	2	3	4	5	6
R1 = 3 k Ω C1 = 470 pF	Needed	Needed	Not needed	Not needed	Needed	Needed	Not needed
R2 = 3 k Ω C2 = 470 pF	Needed	Needed	Needed	Needed	Not needed	Not needed	Not needed

When the PLL circuits are off, CAP1 and CAP2 should be left open or used as shown in the recommended example.

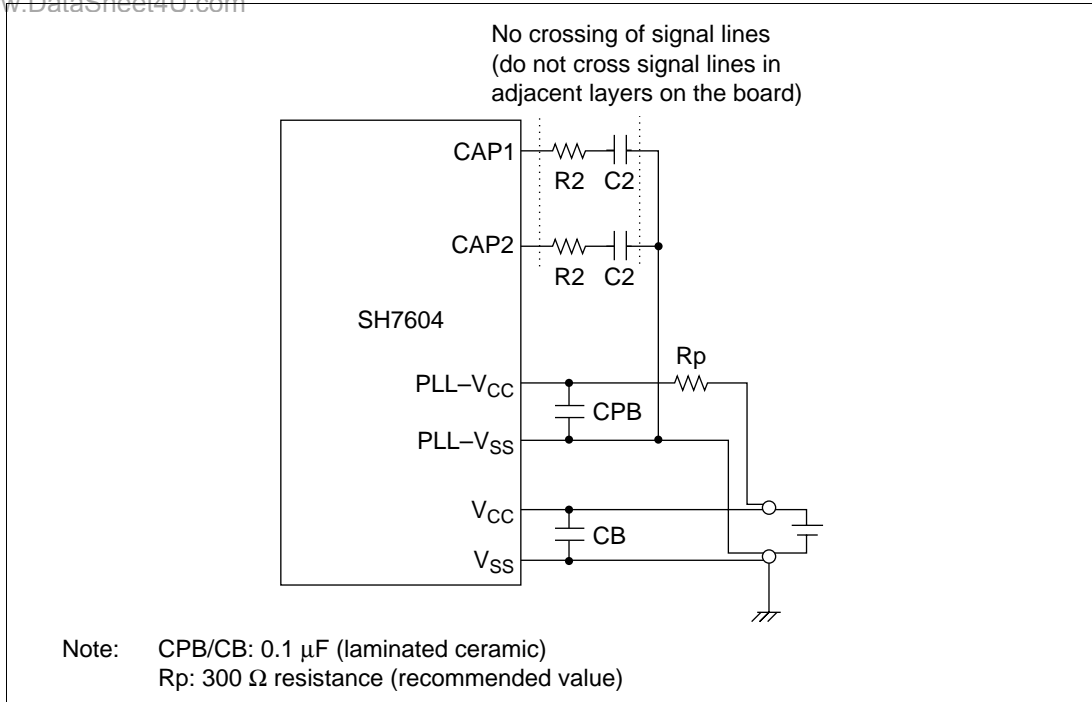

Figure 3.9 Design Considerations when Using PLL Oscillation Circuits

3.3 Bus Width of the CS0 Area

Pins MD3 and MD4 are used to specify the bus width of the CS0 area (boot ROM area). The pin combination and functions are listed in table 3.9. Do not switch the MD4 and MD3 pins while they are operating. Switching them will cause operating errors.

Table 3.9 Bus Width of the CS0 Area

Pin		Function
MD4	MD3	
0	0	8-bit bus width selected
0	1	16-bit bus width selected
1	0	32-bit bus width selected
1	1	Setting prohibited

3.4 Switching between Master Mode and Slave Mode

The SH7604 has two master modes and a slave mode for bus rights that can be selected with the MD5 pin. The master modes consist of a total master mode and a partial-share master mode, which are specified using the MD5 pin and the partial-share space specification bit (PSHR) in bus control register 1 (BCR1). When the slave mode is selected with the MD5 pin, the device enters total slave mode. When master mode is selected with the MD5 pin and partial-space share is specified with the PSHR bit, the device enters partial-share master mode. When partial-space share is not specified with the PSHR bit, the device enters total master mode.

Total master mode has rights to bus use. External devices can be accessed freely. The bus can be allocated to another CPU upon request.

Total slave mode does not have any rights to bus use. When an external device is accessed, bus rights have to be requested from the master CPU, and permission to use the bus gained, before the external device can be accessed.

Partial-share master mode lacks bus rights only for the CS2 space. To access the CS2 space, bus rights must first be requested from the master CPU, and permission granted. This mode has bus rights for all other spaces and does not require a request for the bus when accessing them (table 3.10). Do not change MD5 while external device accesses are in progress.

Table 3.10 Master Modes and Slave Mode

Mode	MD5 Total Slave Mode Specification Pin	PSHR Partial-Share Bit	Function
Total slave mode	1	(Not used)	Has no bus rights. To use the bus, it must request the bus and receive permission from the master CPU.
Partial-share master mode	0	1	Has bus rights to CS0, CS1, and CS3 spaces, but not normally to CS2. To access CS2, it must first request and be granted bus rights.
Total master mode	0	0	Always has bus rights. Grants bus rights to slave CPUs.

DataSheet4U.com

et4U.com

DataShee

DataSheet4U.com

www.DataSheet4U.com

Section 4 Exception Handling

4.1 Overview

4.1.1 Types of Exception Handling and Priority Order

Exception handling is initiated by four sources: resets, address errors, interrupts, and instructions (table 4.1). When several exception handling sources occur at once, they are processed according to priority.

Table 4.1 Types of Exception Handling and Priority Order

Exception	Source	Priority	
Reset	Power-on reset	High	
	Manual reset		
Address error	CPU address error		
	DMA address error		
Interrupt	NMI		
	User break		
	IRL (IRL1–IRL15 (set with IRL3, IRL2, IRL1, IRL0 pins))		
	On-chip peripheral modules		Division unit (DIVU)
			Direct memory access controller (DMAC)
			Watchdog timer (WDT)
			Compare match interrupt (part of the bus state controller)
			Serial communication interface (SCI)
16-bit free-running timer (FRT)			
Instructions	Trap instruction (TRAPA)	Low	
	General illegal instructions (undefined code)		
	Illegal slot instructions (undefined code placed directly following a delayed branch instruction ^{*1} or instructions that rewrite the PC ^{*2})		

- Notes: 1. Delayed branch instructions: JMP, JSR, BRA, BSR, RTS, RTE, BF/S, BT/S, BSRF, BRAF
 2. Instructions that rewrite the PC: JMP, JSR, BRA, BSR, RTS, RTE, BT, BF, TRAPA, BF/S, BT/S, BSRF, BRAF

4.1.2 Exception Handling Operations

Exception handling sources are detected, and exception handling started, according to the timing shown in table 4.2.

Table 4.2 Timing of Exception Source Detection and Start of Exception Handling

Exception Source		Timing of Source Detection and Start of Handling
Reset	Power-on reset	Starts when the NMI pin is high and the $\overline{\text{RES}}$ pin changes from low to high.
	Manual reset	Starts when the NMI pin is low and the $\overline{\text{RES}}$ pin changes from low to high.
Address error		Detected when instruction is decoded and starts when the previous executing instruction finishes executing.
Interrupts		Detected when instruction is decoded and starts when the previous executing instruction finishes executing.
Instructions	Trap instruction	Starts from the execution of a TRAPA instruction.
	General illegal instructions	Starts from the decoding of undefined code anytime except after a delayed branch instruction (delay slot).
	Illegal slot instructions	Starts from the decoding of undefined code placed directly following a delayed branch instruction (delay slot) or of an instruction that rewrites the PC.

DataSheet4U.com

When exception handling starts, the CPU operates as follows:

1. Exception handling triggered by reset

The initial values of the program counter (PC) and stack pointer (SP) are fetched from the exception vector table (PC and SP are respectively addresses H'00000000 and H'00000004 for a power-on reset and addresses H'00000008 and H'0000000C addresses for a manual reset). See section 4.1.3, Exception Vector Table, for more information. 0 is then written to the vector base register (VBR) and 1111 is written to the interrupt mask bits (I3–I0) of the status register. The program begins running from the PC address fetched from the exception vector table.

2. Exception handling triggered by address errors, interrupts, and instructions

SR and PC are saved to the stack address indicated by R15. For interrupt exception handling, the interrupt priority level is written to the SR's interrupt mask bits (I3–I0). For address error and instruction exception handling, the I3–I0 bits are not affected. The start address is then fetched from the exception vector table and the program begins running from that address.

4.1.3 Exception Vector Table

Before exception handling begins, the exception vector table must be written in memory. The exception vector table stores the start addresses of exception service routines. (The reset exception table holds the initial values of PC and SP.)

All exception sources are given different vector numbers and vector table address offsets, from which the vector table addresses are calculated. During exception handling, the start addresses of the exception service routines are fetched from the exception vector table.

Table 4.3 lists the vector numbers and vector table address offsets. Table 4.4 shows vector table address calculations.

Table 4.3 Exception Vector Table

Exception Source		Vector Number	Vector Table Address Offset	Vector Address
Power-on reset	PC	0	H'00000000–H'00000003	Vector number × 4
	SP	1	H'00000004–H'00000007	
Manual reset	PC	2	H'00000008–H'0000000B	
	SP	3	H'0000000C–H'0000000F	
General illegal instruction		4	H'00000010–H'00000013	VBR + (vector number × 4)
(Reserved by system)		5	H'00000014–H'00000017	
Slot illegal instruction		6	H'00000018–H'0000001B	
(Reserved by system)		7	H'0000001C–H'0000001F	
		8	H'00000020–H'00000023	
CPU address error		9	H'00000024–H'00000027	
DMA address error		10	H'00000028–H'0000002B	
Interrupt	NMI	11	H'0000002C–H'0000002F	
	User break	12	H'00000030–H'00000033	
(Reserved by system)		13	H'00000034–H'00000037	
		:	:	
		31	H'0000007C–H'0000007F	
Trap instruction (user vector)		32	H'00000080–H'00000083	
		:	:	
		63	H'000000FC–H'000000FF	

Table 4.3 Exception Processing Vector Table (cont)

Exception Source	Vector Number	Vector Table Address Offset	Vector Addresses
Interrupt	IRL1* ¹	64* ²	H'00000100–H'00000103
	IRL2* ¹	65* ²	H'00000104–H'00000107
	IRL3* ¹		
	IRL4* ¹	66* ²	H'00000108–H'0000010B
	IRL5* ¹		
	IRL6* ¹	67* ²	H'0000010C–H'0000010F
	IRL7* ¹		
	IRL8* ¹	68* ²	H'00000110–H'00000113
	IRL9* ¹		
	IRL10* ¹	69* ²	H'00000114–H'00000117
	IRL11* ¹		
	IRL12* ¹	70* ²	H'00000118–H'0000011B
	IRL13* ¹		
	IRL14* ¹	71* ²	H'0000011C–H'0000011F
	IRL15* ¹		
On-chip peripheral module* ³	0* ⁴	H'00000000–H'00000003	VBR + (vector number × 4)
	:	:	
	255* ⁴	H'000003FC–H'000003FF	

Notes: 1. When 1110 is input to the IRL3, IRL2, IRL1, and IRL0 pins, an IRL1 interrupt results. When 0000 is input, an IRL15 interrupt results.

2. External vector number fetches can be performed without using the auto-vector numbers in this table.

3. The vector numbers and vector table address offsets for each on-chip peripheral module interrupt are given in section 5, Interrupt Controller, and table 5.4, Interrupt Exception Vectors and Priorities.

4. Vector numbers are set in the on-chip vector number register. See section 5.3, Description of Registers, section 9, Direct Memory Access Controller, and section 10, Division Unit, for more information.

Table 4.4 Calculating Exception Vector Table Addresses

Exception Source	Vector Table Address Calculation
Power-on reset	(Vector table address) = (vector table address offset)
Manual reset	= (vector number) × 4
Other exception handling	(Vector table address) = VBR + (vector table address offset)
	= VBR + (vector number) × 4

Note: VBR: Vector base register

Vector table address offset: See table 4.3.

Vector number: See table 4.3.

4.2 Resets

4.2.1 Types of Resets

Resets have the highest priority of any exception source. There are two types of resets: manual resets and power-on resets. As table 4.5 shows, both types of resets initialize the internal status of the CPU. In power-on resets, all registers of the on-chip peripheral modules are initialized; in manual resets, registers of all on-chip peripheral modules except the bus state controller (BSC), user break controller (UBC) and frequency modification register are initialized. (Use the power-on reset when turning the power on.)

DataSheet4U.com

Table 4.5 Types of Resets

Type	Conditions for Transition to Reset Status		Internal Status	
	NMI Pin	RES Pin	CPU	On-Chip Peripheral Modules
Power-on reset	High	Low	Initialized	Initialized
Manual reset	Low	Low	Initialized	Initialized except for BSC, UBC, and FMR register

4.2.2 Power-On Reset

When the NMI pin is high and the $\overline{\text{RES}}$ pin is driven low, the device performs a power-on reset. For a reliable reset, the $\overline{\text{RES}}$ pin should be kept low for at least the duration of the oscillation settling time (when the PLL circuit is halted) or for 20 clock cycles (when the PLL circuit is running). During a power-on reset, the CPU's internal state and all on-chip peripheral module registers are initialized. See appendix A, Pin States, for the state of individual pins in the power-on reset state.

In a power-on reset, power-on reset exception handling starts when the NMI pin is kept high and the $\overline{\text{RES}}$ pin is first driven low for a set period of time and then returned to high. The CPU will then operate as follows:

1. The initial value (execution start address) of the program counter (PC) is fetched from the exception vector table.
2. The initial value of the stack pointer (SP) is fetched from the exception vector table.
3. The vector base register (VBR) is cleared to H'00000000 and the interrupt mask bits (I3–I0) of the status register (SR) are set to H'F (1111).
4. The values fetched from the exception vector table are set in the PC and SP, and the program begins executing.

4.2.3 Manual Reset

DataSheet4U.com

When the NMI pin is low and the $\overline{\text{RES}}$ pin is driven low, the device executes a manual reset. For a reliable reset, the $\overline{\text{RES}}$ pin should be kept low for at least 20 clock cycles. During a manual reset, the CPU's internal state is initialized. Registers of all on-chip peripheral modules except the bus state controller (BSC), user break controller (UBC) and the frequency modification register are initialized. Since the BSC is not affected, the DRAM and synchronous DRAM refresh control functions remain operational even if the manual reset state continues for a long period of time. When the chip enters the manual reset state in the middle of a bus cycle, manual reset exception handling does not start until the bus cycle has ended. Thus, manual resets do not abort bus cycles. See appendix A, Pin States, for the state of individual pins in the manual reset state.

In a manual reset, manual reset exception handling starts when the NMI pin is kept low and the $\overline{\text{RES}}$ pin is first kept low for a set period of time and then returned to high. The CPU will then operate in the same way as for a power-on reset.

4.3 Address Errors

4.3.1 Sources of Address Errors

Address errors occur when instructions are fetched or data read or written, as shown in table 4.6.

Table 4.6 Bus Cycles and Address Errors

Bus Cycle			
Type	Bus Master	Bus Cycle Description	Address Errors
Instruction fetch	CPU	Instruction fetched from even address	None (normal)
		Instruction fetched from odd address	Address error occurs
		Instruction fetched from other than on-chip peripheral module space	None (normal)
		Instruction fetched from on-chip peripheral module space	Address error occurs
Data read/write	CPU or DMAC	Word data accessed from even address	None (normal)
		Word data accessed from odd address	Address error occurs
		Longword data accessed from a longword boundary	None (normal)
		Longword data accessed from other than a longword boundary	Address error occurs
		Access of cache purge space, address array read/write space or on-chip I/O space by PC-relative addressing	Address error occurs
		Access of cache purge space, address array read/write space, data array read/write space or on-chip I/O space by a TAS.B instruction	Address error occurs
		Byte data accessed in on-chip peripheral module space at addresses H'FFFFFF00 to H'FFFFFFF	Address error occurs
		Word or longword data accessed in on-chip peripheral module space at addresses H'FFFFFF00 to H'FFFFFFF	None (normal)
		Longword data accessed in on-chip peripheral module space at addresses H'FFFFFFE00 to H'FFFFFFEFF	Address error occurs
Word or byte data accessed in on-chip peripheral module space at addresses H'FFFFFFE00 to H'FFFFFFEFF	None (normal)		

Notes: 1. Address errors do not occur during the synchronous DRAM mode register write cycle.

2. 16-byte DMAC transfers use longword accesses.

4.3.2 Address Error Exception Handling

When an address error occurs, address error exception handling begins after the end of the bus cycle in which the error occurred and completion of the executing instruction. The CPU operates as follows:

1. The status register (SR) is saved to the stack.
2. The program counter (PC) is saved to the stack. The PC value saved is the start address of the instruction to be executed after the last instruction executed .
3. The exception service routine start address is fetched from the exception vector table entry that corresponds to the address error that occurred, and the program starts executing from that address. The jump that occurs is not a delayed branch.

4.4 Interrupts

4.4.1 Interrupt Sources

Table 4.7 shows the sources that initiate interrupt exception handling. These are divided into NMI, user breaks, IRL, and on-chip peripheral modules. Each interrupt source is allocated a different vector number and vector table address offset. See table 5.4, Interrupt Exception Vectors and Priority Order, in section 5, Interrupt Controller, for more information.

Table 4.7 Types of Interrupt Sources

Type	Request Source	Number of Sources
NMI	NMI pin (external input)	1
User break	User break controller	1
IRL	IRL1–IRL15 (external input)	15
On-chip peripheral module	Direct memory access controller (DMAC)	2
	Division unit (DIVU)	1
	Serial communication interface (SCI)	4
	Free-running timer (FRT)	3
	Watchdog timer (WDT)	1
	Bus state controller (BSC)	1

4.4.2 Interrupt Priority Levels

The interrupt priority order is predetermined. When multiple interrupts occur simultaneously, the interrupt controller (INTC) determines their relative priorities and begins exception handling accordingly.

The priority order of interrupts is expressed as priority levels 0–16, with priority 0 the lowest and priority 16 the highest. The NMI interrupt has priority 16 and cannot be masked, so it is always accepted. The user break interrupt priority level is 15 and IRL interrupts have priorities of 1–15. On-chip peripheral module interrupt priority levels can be set freely using the INTC's interrupt priority level setting registers A and B (IPRA and IPRB) as shown in table 4.8. The priority levels that can be set are 0–15. Level 16 cannot be set. For more information on IPRA and IPRB, see sections 5.3.1 and 5.3.2, Interrupt Priority Level Setting Registers A and B (IPRA and IPRB).

Table 4.8 Interrupt Priority Order

Type	Priority Level	Comment
NMI	16	Fixed priority level. Cannot be masked.
User break	15	Fixed priority level.
IRL	1–15	Set with $\overline{\text{IRL3}}\text{--}\overline{\text{IRL0}}$ pins.
On-chip peripheral module	0–15	Set with interrupt priority level setting registers A and B (IPRA and IPRB).

DataSheet4U.com

4.4.3 Interrupt Exception Handling

When an interrupt occurs, its priority level is ascertained by the interrupt controller (INTC). NMI is always accepted, but other interrupts are only accepted if they have a priority level higher than the priority level set in the interrupt mask bits (I3–I0) of the status register (SR).

When an interrupt is accepted, exception handling begins. In interrupt exception handling, the CPU saves SR and the program counter (PC) to the stack. The priority level value of the accepted interrupt is written to SR bits I3–I0. For NMI, however, the priority level is 16, but the value set in I3–I0 is H'F (level 15). Next, the start address of the exception service routine is fetched from the exception vector table for the accepted interrupt, that address is jumped to and execution begins. For more information about interrupt exception handling, see section 5.4, Interrupt Operation.

4.5 Exceptions Triggered by Instructions

4.5.1 Instruction-Triggered Exception Types

Exception handling can be triggered by a trap instruction, general illegal instruction or illegal slot instruction, as shown in table 4.9.

Table 4.9 Types of Exceptions Triggered by Instructions

Type	Source Instruction	Comment
Trap instruction	TRAPA	—
Illegal slot instruction	Undefined code placed immediately after a delayed branch instruction (delay slot) and instructions that rewrite the PC	Delayed branch instructions: JMP, JSR, BRA, BSR, RTS, RTE, BF/S, BT/S, BSRF, BRAF Instructions that rewrite the PC: JMP, JSR, BRA, BSR, RTS, RTE, BT, BF, TRAPA, BF/S, BT/S, BSRF, BRAF
General illegal instruction	Undefined code anywhere besides in a delay slot	—

4.5.2 Trap Instructions

DataSheet4U.com

When a TRAPA instruction is executed, trap instruction exception handling starts. The CPU operates as follows:

1. The status register (SR) is saved to the stack.
2. The program counter (PC) is saved to the stack. The PC value saved is the start address of the instruction to be executed after the TRAPA instruction.
3. The exception service routine start address is fetched from the exception vector table entry that corresponds to the vector number specified by the TRAPA instruction. That address is jumped to and the program starts executing. The jump that occurs is not a delayed branch.

4.5.3 Illegal Slot Instructions

An instruction placed immediately after a delayed branch instruction is said to be placed in a delay slot. If the instruction placed in the delay slot is undefined code, illegal slot exception handling begins when the undefined code is decoded. Illegal slot exception handling also starts up when an instruction that rewrites the program counter (PC) is placed in a delay slot. The exception handling starts when the instruction is decoded. The CPU handles an illegal slot instruction as follows:

1. The status register (SR) is saved to the stack.
2. The program counter (PC) is saved to the stack. The PC value saved is the jump address of the delayed branch instruction immediately before the undefined code or the instruction that rewrites the PC.
3. The exception service routine start address is fetched from the exception vector table entry that corresponds to the exception that occurred. That address is jumped to and the program starts executing. The jump that occurs is not a delayed branch.

4.5.4 General Illegal Instructions

When undefined code placed anywhere other than immediately after a delayed branch instruction (i.e., in a delay slot) is decoded, general illegal instruction exception handling starts. The CPU handles general illegal instructions in the same way as illegal slot instructions. Unlike processing of illegal slot instructions, however, the program counter value stored is the start address of the undefined code.

4.6 When Exception Sources are Not Accepted

When an address error or interrupt is generated after a delayed branch instruction or interrupt-disabled instruction, it is sometimes not immediately accepted but is stored instead, as described in table 4.10. When this happens, it will be accepted when an instruction for which exception acceptance is possible is decoded.

DataSheet4U.com

Table 4.10 Exception Source Generation Immediately after a Delayed Branch Instruction or Interrupt-Disabled Instruction

Point of Occurrence	Exception Source	
	Address Error	Interrupt
Immediately after a delayed branch instruction* ¹	Not accepted	Not accepted
Immediately after an interrupt-disabled instruction* ²	Accepted	Not accepted

Notes: 1. Delayed branch instructions: JMP, JSR, BRA, BSR, RTS, RTE, BF/S, BT/S, BSRF, BRAF

2. Interrupt-disabled instructions: LDC, LDC.L, STC, STC.L, LDS, LDS.L, STS, STS.L

4.6.1 Immediately after a Delayed Branch Instruction

When an instruction placed immediately after a delayed branch instruction (delay slot) is decoded, neither address errors nor interrupts are accepted. The delayed branch instruction and the instruction located immediately after it (delay slot) are always executed consecutively, so no exception handling occurs between the two.

www.DataSheet4U.com

DataSheet4U.com

4.6.2 Immediately after an Interrupt-Disabled Instruction

When an instruction immediately following an interrupt-disabled instruction is decoded, interrupts are not accepted. Address errors are accepted.

4.7 Stack Status after Exception Handling

The status of the stack after exception handling ends is as shown in table 4.11.

Table 4.11 Stack Status after Exception Handling

Type	Stack Status		
Address error	SP →	Address of instruction after executed instruction	32 bits
		SR	32 bits
Trap instruction	SP →	Address of instruction after TRAPA instruction	32 bits
		SR	32 bits
General illegal instruction	SP →	Start address of illegal instruction	32 bits
		SR	32 bits
Interrupt	SP →	Address of instruction after executed instruction	32 bits
		SR	32 bits
Illegal slot instruction	SP →	Jump destination address of delayed branch instruction	32 bits
		SR	32 bits

4.8 Usage Notes

4.8.1 Value of Stack Pointer (SP)

The value of the stack pointer must always be a multiple of four, otherwise an address error will occur when the stack is accessed during exception handling.

4.8.2 Value of Vector Base Register (VBR)

The value of the vector base register must always be a multiple of four, otherwise an address error will occur when the vector table is accessed during exception handling.

4.8.3 Address Errors Caused by Stacking of Address Error Exception Handling

If the stack pointer value is not a multiple of four, an address error will occur during stacking of the exception handling (interrupts, etc.). Address error exception handling will begin as soon as the first exception handling is ended, but address errors will continue to occur. To ensure that address error exception handling does not go into an endless loop, no address errors are accepted at that point. This allows program control to be shifted to the address error exception service routine and enables error handling to be carried out.

When an address error occurs during exception handling stacking, the stacking bus cycle (write) is executed. In stacking of the status register (SR) and program counter (PC), the SP is decremented by 4 for both, so the value of SP will not be a multiple of four after the stacking either. The address value output during stacking is the SP value, so the address where the error occurred is itself output. This means that the write data stacked will be undefined.

4.8.4 Manual Reset during Register Access

Do not initiate a manual reset during access of a bus state controller (BSC) or user break controller (UBC) register, otherwise a write error may result.

DataSheet4U.com

et4U.com

DataShee

DataSheet4U.com

www.DataSheet4U.com

DataSheet4U.com

et4U.com

DataShee

DataSheet4U.com

www.DataSheet4U.com

Section 5 Interrupt Controller (INTC)

5.1 Overview

The interrupt controller (INTC) ascertains the priority of interrupt sources and controls interrupt requests to the CPU. The INTC has registers for setting the priority of each interrupt which allow the user to set the order of priority in which interrupt requests are handled.

5.1.1 Features

The INTC has the following features:

- 16 interrupt priority levels: By setting the two interrupt-priority level registers, the priorities of on-chip peripheral module interrupts can be set at 16 levels for different request sources.
- Settable vector numbers for on-chip peripheral module interrupts: two vector number setting registers enable on-chip peripheral module interrupt vector numbers to be set in the range 0–127 by interrupt source.
- The IRL interrupt vector number setting method can be selected: Either of two modes can be selected by a register setting: auto-vector mode in which vector numbers are determined internally, and external vector mode in which vector numbers are set externally.

5.1.2 Block Diagram

DataSheet4U.com

Figure 5.1 shows a block diagram of the INTC.

et4U.com

DataShee

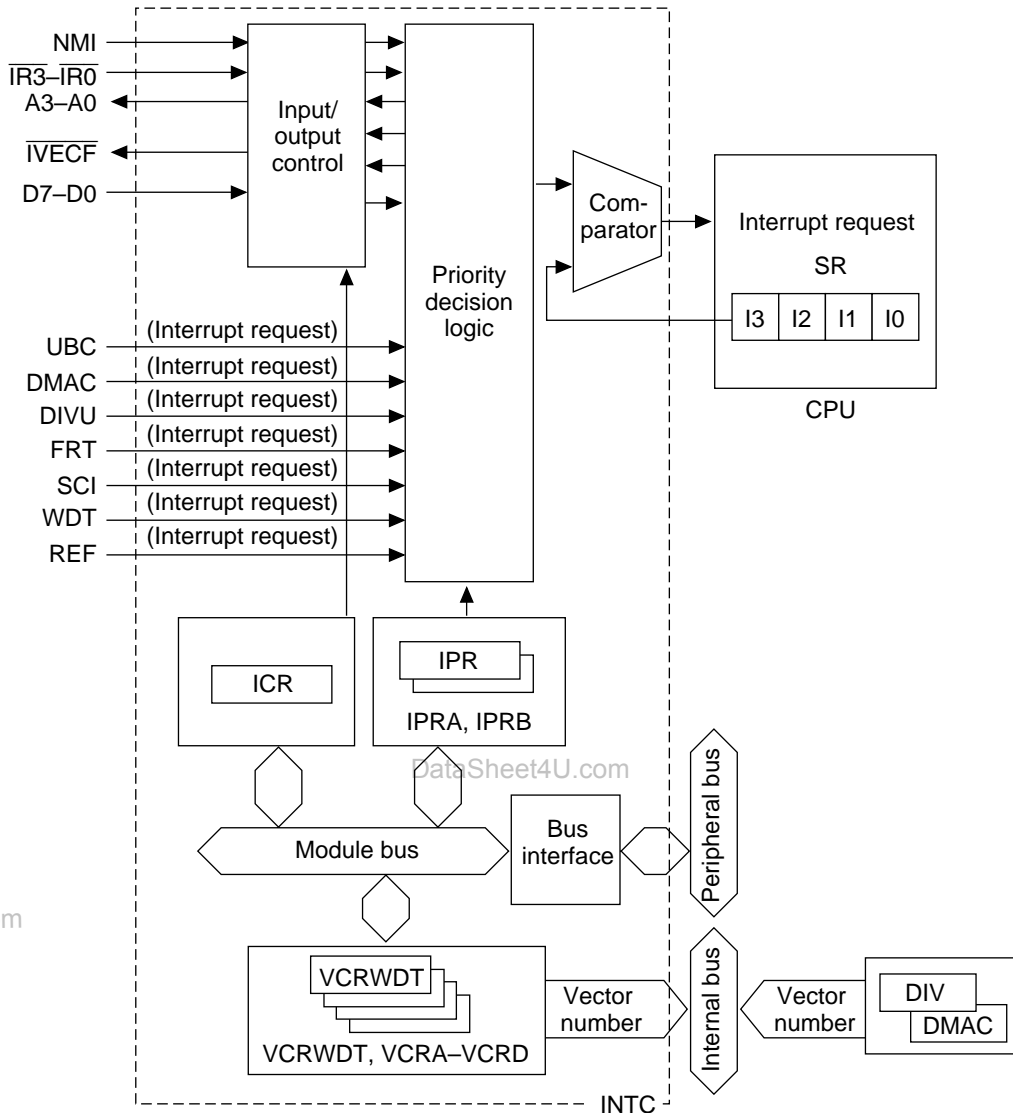

UBC:	User break controller	ICR:	Interrupt control register
DMAC:	Direct memory access controller	IPRA/B:	Interrupt priority level setting registers A and B
DIVU:	Division unit	VCRWDT:	Vector number setting register WDT
FRT:	Free-running timer	VCRA-D:	Vector number setting registers A-D
SCI:	Serial communication interface	SR:	Status register
WDT:	Watchdog timer		
REF:	Refresh request within bus state controller		

Figure 5.1 INTC Block Diagram

5.1.3 Pin Configuration

Table 5.1 shows the INTC pin configuration.

Table 5.1 Pin Configuration

Name	Abbreviation	I/O	Function
Nonmaskable interrupt input pin	NMI	I	Input of nonmaskable interrupt request signal
Level request interrupt input pins	$\overline{\text{IRL3}}\text{--}\overline{\text{IRL0}}$	I	Input of maskable interrupt request signals
Interrupt acceptance level output pins	A3–A0	O	In external vector mode, output an interrupt level signal when an IRL interrupt is accepted
External vector fetch pin	$\overline{\text{IVECF}}$	O	Indicates external vector read cycle
External vector number input pins	D7–D0	I	Input external vector number

5.1.4 Register Configuration

The INTC has the eight registers shown in table 5.2. These registers perform various INTC functions including setting interrupt priority, and controlling external interrupt input signal detection.

DataSheet4U.com

Table 5.2 Register Configuration

Name	Abbr.	R/W	Initial Value	Address	Access Size*
Interrupt priority level setting register A	IPRA	R/W	H'0000	H'FFFFFFE2	8, 16
Interrupt priority level setting register B	IPRB	R/W	H'0000	H'FFFFFFE60	8, 16
Vector number setting register A	VCRA	R/W	H'0000	H'FFFFFFE62	8, 16
Vector number setting register B	VCRB	R/W	H'0000	H'FFFFFFE64	8, 16
Vector number setting register C	VCRC	R/W	H'0000	H'FFFFFFE66	8, 16
Vector number setting register D	VCRD	R/W	H'0000	H'FFFFFFE68	8, 16
Vector number setting register WDT	VCRWDT	R/W	H'0000	H'FFFFFFE4	8, 16
Vector number setting register DIV	VCRDIV	R/W	—	H'FFFFFF0C	32
Vector number setting register DMAC0	VCRDMA0	R/W	—	H'FFFFFFA0	32
Vector number setting register DMAC1	VCRDMA1	R/W	—	H'FFFFFFA8	32
Interrupt control register	ICR	R/W	H'8000/ H'0000*	H'FFFFFFE0	8, 16

—: Undefined

Note: The value when the NMI pin is high is H'8000; when the NMI pin is low, it is H'0000. See the sections 9, Direct Memory Access Controller, and 10, Division Unit, for more information on VCRDIV, VCRDMA0, and VCRDMA1.

DataSheet4U.com

5.2 Interrupt Sources

There are four types of interrupt sources: NMI, user breaks, IRL, and on-chip peripheral modules. Each interrupt has a priority expressed as a priority level (0 to 16, with 0 the lowest and 16 the highest). Giving an interrupt a priority level of 0 masks it.

5.2.1 NMI Interrupt

The NMI interrupt has priority 16 and is always accepted. Input at the NMI pin is detected by edge. Use the NMI edge select bit (NMIE) in the interrupt control register (ICR) to select either the rising or falling edge. NMI interrupt exception handling sets the interrupt mask level bits (I3–I0) in the status register (SR) to level 15.

5.2.2 User Break Interrupt

A user break interrupt has priority level 15 and occurs when the break condition set in the user break controller (UBC) is satisfied. User break interrupt exception handling sets the interrupt mask level bits (I3–I0) in the status register (SR) to level 15. For more information about the user break interrupt, see section 6, User Break Controller.

5.2.3 IRL Interrupts

IRL interrupts are requested by input from pins $\overline{\text{IRL3}}\text{--}\overline{\text{IRL0}}$. Fifteen interrupts, IRL15–IRL1, can be input externally via pins $\overline{\text{IRL3}}\text{--}\overline{\text{IRL0}}$. The priority levels of interrupts IRL15–IRL0 are 15–1, respectively, and their vector numbers are 71–64. Set the vector numbers with the IRL interrupt vector mode select (VECMD) bit of the interrupt control register (ICR) to enable external input. External input of vector numbers consists of vector numbers 0–127 from the external vector input pins (D7–D0). Internal vectors are called auto-vectors and vectors input externally are called external vectors. Table 5.3 lists IRL priority levels and auto vector numbers.

When an IRL interrupt is accepted in external vector mode, the IRL interrupt level is output from the interrupt acceptance level output pins (A3–A0). The external vector fetch pin ($\overline{\text{IVECF}}$) is also asserted. The external vector number is read from pins D7–D0 at this time. Figures 5.2 and 5.3 show interrupt connection examples.

IRL interrupt exception processing sets the interrupt mask level bits (I3 to I0) in the status register (SR) to the priority level value of the IRL interrupt that was accepted.

Table 5.3 IRL Interrupt Priority Levels and Auto-Vector Numbers

Pin				Priority Level	Vector Number
$\overline{\text{IRL3}}$	$\overline{\text{IRL2}}$	$\overline{\text{IRL1}}$	$\overline{\text{IRL0}}$		
0	0	0	0	15	71
0	0	0	1	14	
0	0	1	0	13	70
0	0	1	1	12	
0	1	0	0	11	69
0	1	0	1	10	
0	1	1	0	9	68
0	1	1	1	8	
1	0	0	0	7	67
1	0	0	1	6	
1	0	1	0	5	66
1	0	1	1	4	
1	1	0	0	3	65
1	1	0	1	2	
1	1	1	0	1	64

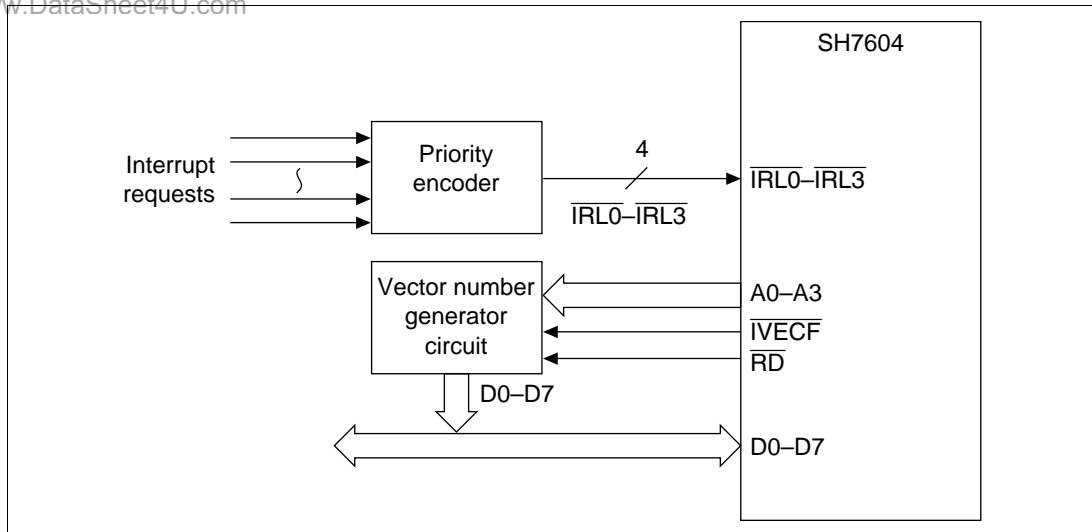

Figure 5.2 Example of Connections for External Vector Mode Interrupts

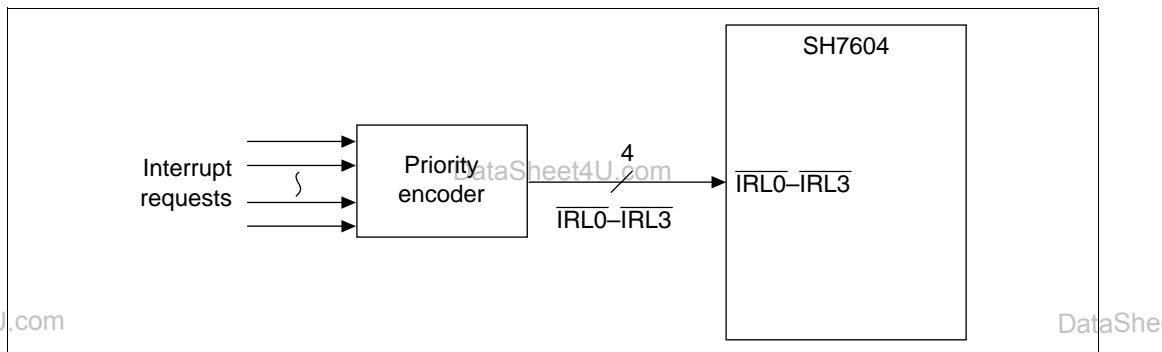

Figure 5.3 Example of Connections for Auto-Vector Mode Interrupts

Figure 5.4 shows the interrupt fetch cycle for the external vector mode. During this cycle, $\overline{CS0}$ – $\overline{CS3}$ stay high. A26–A4 output undefined values. The \overline{WAIT} pin is sampled, but programmable waits are not valid.

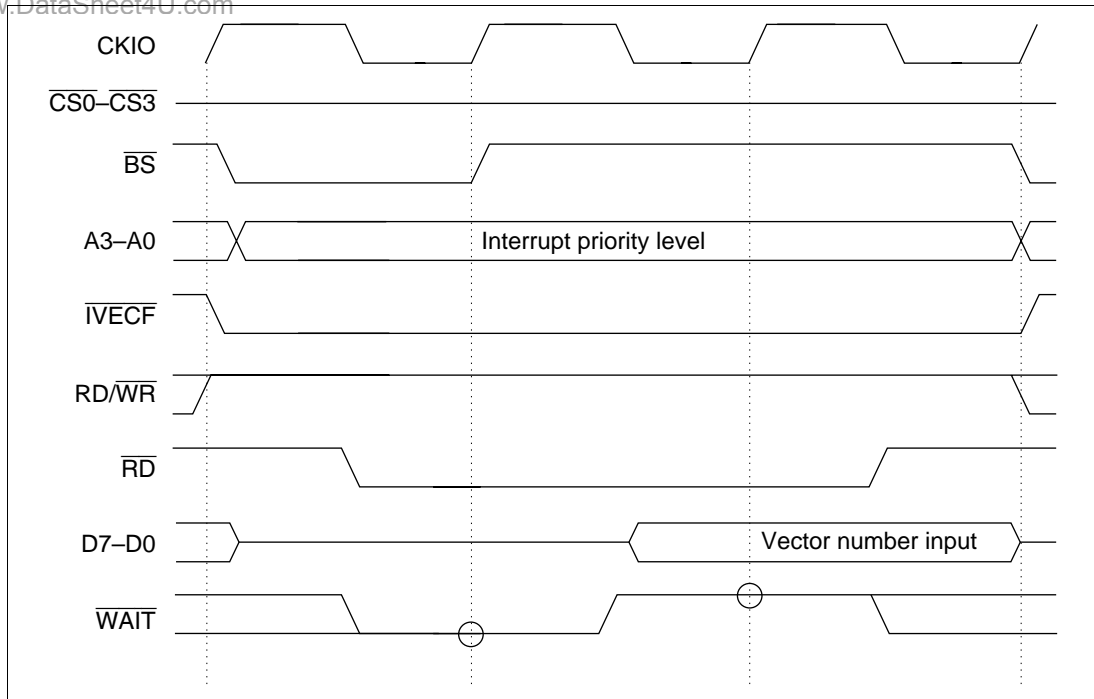

Figure 5.4 External Vector Mode Interrupt Vector Fetch Cycle

DataSheet4U.com

5.2.4 On-chip Peripheral Module Interrupts

On-chip peripheral module interrupts are interrupts generated by the following 6 on-chip peripheral modules:

- Division unit (DIVU)
- Direct memory access controller (DMAC)
- Serial communication interface (SCI)
- Bus state controller (BSC)
- Watchdog timer (WDT)
- Free-running timer (FRT)

A different interrupt vector is assigned to each interrupt source, so the exception service routine does not have to decide which interrupt has occurred. Priority levels between 0 and 15 can be assigned to individual on-chip peripheral modules in interrupt priority registers A and B (IPRA and IPRB). On-chip peripheral module interrupt exception handling sets the interrupt mask level bits (I3-I0) in the status register (SR) to the priority level value of the on-chip peripheral module interrupt that was accepted.

www.DataSheet4U.com

5.2.5 Interrupt Exception Vectors and Priority Order

Table 5.4 lists interrupt sources and their vector numbers, vector table address offsets and interrupt priorities.

Each interrupt source is allocated a different vector number and vector table address offset. Vector table addresses are calculated from vector numbers and address offsets. In interrupt exception handling, the exception service routine start address is fetched from the vector table entry indicated by the vector table address. See table 4.4, Calculating Exception Vector Table Addresses, for more information on this calculation.

IRL interrupts IRL15–IRL1 have interrupt priority levels of 15–1, respectively. On-chip peripheral module interrupt priorities can be set freely between 0 and 15 for each module by setting interrupt priority registers A and B (IPRA and IPRB). The ranking of interrupt sources for IPRA and IPRB, however, must be the order listed under Priority Within IPR Setting Unit in table 5.4 and cannot be changed. A reset assigns priority level 0 to on-chip peripheral module interrupts. If the same priority level is assigned to two or more interrupt sources and interrupts from those sources occur simultaneously, their priority order is the default priority order indicated at the right in table 5.4.

DataSheet4U.com

et4U.com

DataShee

DataSheet4U.com

www.DataSheet4U.com

Table 5.4 Interrupt Exception Vectors and Priority Order

Interrupt Source	Interrupt Priority Order (Initial Value)	IPR (Bit Numbers)	Priority within IPR Setting Unit	Vectors		Default Priority
				Vector No.	Vector Table Address	
NMI	16	—	—	11	VBR + (vector No. × 4)	High
User break	15	—	—	12		
IRL15	15	—	—	71 ^{*1}		
IRL14	14	—	—			
IRL13	13	—	—	70 ^{*1}		
IRL12	12	—	—			
IRL11	11	—	—	69 ^{*1}		
IRL10	10	—	—			
IRL9	9	—	—	68 ^{*1}		
IRL8	8	—	—			
IRL7	7	—	—	67 ^{*1}		
IRL6	6	—	—			
IRL5	5	—	—	66 ^{*1}		
IRL4	4	—	—			
IRL3	3	—	—	65 ^{*1}		
IRL2	2	—	—			
IRL1	1	—	—	64 ^{*1}		
DIVU	OVFI	0–15 (0)	IPRA (15–12)	0–127 ^{*2}		Low

Table 5.4 Interrupt Exception Vectors and Priority Order (cont)

Interrupt Source	Interrupt Priority Order (Initial Value)	IPR (Bit Numbers)	Priority within IPR Setting Unit	Vectors		Default Priority
				Vector No.	Vector Table Address	
DMAC0	Transfer end	0–15 (0)	IPRA (11–8)	1	0–127* ²	VBR + (vector No. × 4)
DMAC1	Transfer end			0	0–127* ²	
WDT	ITI	0–15 (0)	IPRA (7–4)	1	0–127* ²	
REF ³	CMI			0	0–127* ²	
SCI	ERI	0–15 (0)	IPRB (15–12)	3	0–127* ²	
	RXI			2	0–127* ²	
	TXI			1	0–127* ²	
	TEI			0	0–127* ²	
FRT	ICI	0–15 (0)	IPRB (11–8)	2	0–127* ²	
	OCI			1	0–127* ²	
	OVI			0	0–127* ²	
Reserved	—	—	—	128–255	—	Low

- Notes: 1. An external vector number fetch can be performed without using the auto-vector numbers shown in this table. The external vector numbers are 0–127.
 2. Vector numbers are set in the on-chip vector number register.
 3. REF is the refresh control unit within the bus state controller.

5.3 Description of Registers

5.3.1 Interrupt Priority Level Setting Register A (IPRA)

Interrupt priority level setting register A (IPRA) is a 16-bit read/write register that assigns priority levels from 0 to 15 to on-chip peripheral module interrupts. IPRA is initialized to H'0000 by a reset. It is not initialized in standby mode. Unless otherwise specified, 'reset' refers to both power-on and manual resets throughout this manual.

Bit:	15	14	13	12	11	10	9	8
Bit name:	DIVU IP3	DIVU IP2	DIVU IP1	DIVU IP0	DMAC IP3	DMAC IP2	DMAC IP1	DMAC IP0
Initial value:	0	0	0	0	0	0	0	0
R/W:	R/W	R/W	R/W	R/W	R/W	R/W	R/W	R/W
Bit:	7	6	5	4	3	2	1	0
Bit name:	WDT IP3	WDT IP2	WDT IP1	WDT IP0	—	—	—	—
Initial value:	0	0	0	0	0	0	0	0
R/W:	R/W	R/W	R/W	R/W	R	R	R	R

- Bits 15 to 12—Division Unit (DIVU) Interrupt Priority Level (DIVUIP3–DIVUIP0): These bits set the division unit (DIVU) interrupt priority level. There are four bits, so levels 0–15 can be set.
- Bits 11 to 8—DMA Controller Interrupt Priority Level (DMACIP3–DMACIP0): These bits set the DMA controller (DMAC) interrupt priority level. There are four bits, so levels 0–15 can be set. The same level is set for both DMAC channels. When interrupts occur simultaneously, channel 0 has priority.
- Bits 7 to 4—Watchdog Timer (WDT) Interrupt Priority Level (WDTIP3–WDTIP0): These bits set the watchdog timer (WDT) interrupt priority level and bus state controller (BSC) interrupt priority level. There are four bits, so levels 0–15 can be set. When WDT and BSC interrupts occur simultaneously, the WDT interrupt has priority.
- Bits 3 to 0—Reserved: These bits always read 0. The write value should always be 0.

5.3.2 Interrupt Priority Level Setting Register B (IPRB)

Interrupt priority level setting register B (IPRB) is a 16-bit read/write register that assigns priority levels from 0 to 15 to on-chip peripheral module interrupts. IPRB is initialized to H'0000 by a reset. It is not initialized in standby mode.

Bit:	15	14	13	12	11	10	9	8
Bit name:	SCIIP3	SCIIP2	SCIIP1	SCIIP0	FRTIP3	FRTIP2	FRTIP1	FRTIP0
Initial value:	0	0	0	0	0	0	0	0
R/W:	R/W	R/W	R/W	R/W	R/W	R/W	R/W	R/W
Bit:	7	6	5	4	3	2	1	0
Bit name:	—	—	—	—	—	—	—	—
Initial value:	0	0	0	0	0	0	0	0
R/W:	R	R	R	R	R	R	R	R

- Bits 15 to 12—Serial Communication Interface (SCI) Interrupt Priority Level (SCIIP3–SCIIP0): These bits set the serial communication interface (SCI) interrupt priority level. There are four bits, so levels 0–15 can be set.
- Bits 11 to 8—Free-Running Timer (FRT) Interrupt Priority Level (FRTIP3–FRTIP0): These bits set the free-running timer (FRT) interrupt priority level. There are four bits, so levels 0–15 can be set.
- Bits 7 to 0—Reserved: These bits always read 0. The write value should always be 0.

Table 5.5 shows the relationship between on-chip peripheral module interrupts and interrupt priority level setting registers.

Table 5.5 Interrupt Request Sources and IPRA/IPRB

Register	Bits 15 to 12	Bits 11 to 8	Bits 7 to 4	Bits 3 to 0
IPRA	DIVU	DMAC0, DMAC1	WDT	Reserved
IPRB	SCI	FRT	Reserved	Reserved

As table 5.5 shows, two or three on-chip peripheral modules are assigned to each interrupt priority register. Set the priority levels by setting the corresponding 4-bit groups (bits 15 to 12, bits 11 to 8, and bits 7 to 4) with values in the range of H'0 (0000) to H'F (1111). H'0 is interrupt priority level 0 (the lowest); H'F is level 15 (the highest). When two on-chip peripheral modules are assigned to the same bits (DMAC0 and DMAC1, or WDT and DRAM refresh control unit), those two modules have the same priority. A reset initializes IPRA and IPRB to H'0000. They are not initialized in standby mode.

5.3.3 Vector Number Setting Register WDT (VCRWDT)

Vector number setting register WDT (VCRWDT) is a 16-bit read/write register that sets the WDT interval interrupt and BSC compare match interrupt vector numbers (0–127). VCRWDT is initialized to H'0000 by a reset. It is not initialized in standby mode.

Bit:	15	14	13	12	11	10	9	8
Bit name:	—	WITV6	WITV5	WITV4	WITV3	WITV2	WITV1	WITV0
Initial value:	0	0	0	0	0	0	0	0
R/W:	R	R/W	R/W	R/W	R/W	R/W	R/W	R/W
Bit:	7	6	5	4	3	2	1	0
Bit name:	—	BCMV6	BCMV5	BCMV4	BCMV3	BCMV2	BCMV1	BCMV0
Initial value:	0	0	0	0	0	0	0	0
R/W:	R	R/W	R/W	R/W	R/W	R/W	R/W	R/W

- Bits 15, 7—Reserved: These bits always read 0. The write value should always be 0.
- Bits 14 to 8—Watchdog Timer (WDT) Interval Interrupt Vector Number (WITV6–WITV0): These bits set the vector number for the interval interrupt (ITI) of the watchdog timer (WDT). There are seven bits, so the value can be set between 0 and 127.
- Bits 6 to 0—Bus State Controller (BSC) Compare Match Interrupt Vector Number (BCMV6–BCMV0): These bits set the vector number for the compare match interrupt (CMI) of the bus state controller (BSC). There are seven bits, so the value can be set between 0 and 127.

5.3.4 Vector Number Setting Register A (VCRA)

Vector number setting register A (VCRA) is a 16-bit read/write register that sets the SCI receive-error interrupt and receive-data-full interrupt vector numbers (0–127). VCRA is initialized to H'0000 by a reset. It is not initialized in standby mode.

Bit:	15	14	13	12	11	10	9	8
Bit name:	—	SERV6	SERV5	SERV4	SERV3	SERV2	SERV1	SERV0
Initial value:	0	0	0	0	0	0	0	0
R/W:	R	R/W	R/W	R/W	R/W	R/W	R/W	R/W

Bit:	7	6	5	4	3	2	1	0
Bit name:	—	SRXV6	SRXV5	SRXV4	SRXV3	SRXV2	SRXV1	SRXV0
Initial value:	0	0	0	0	0	0	0	0
R/W:	R	R/W	R/W	R/W	R/W	R/W	R/W	R/W

- Bits 15, 7—Reserved: These bits always read 0. The write value should always be 0.
- Bits 14 to 8—Serial Communication Interface (SCI) Receive-Error Interrupt Vector Number (SERV6–SERV0): These bits set the vector number for the serial communication interface (SCI) receive-error interrupt (ERI). There are seven bits, so the value can be set between 0 and 127.
- Bits 6 to 0—Serial Communication Interface (SCI) Receive-Data-Full Interrupt Vector Number (SRXV6–SRXV0): These bits set the vector number for the serial communication interface (SCI) receive-data-full interrupt (RXI). There are seven bits, so the value can be set between 0 and 127.

DataSheet4U.com

5.3.5 Vector Number Setting Register B (VCRB)

Vector number setting register B (VCRB) is a 16-bit read/write register that sets the SCI transmit-data-empty interrupt and transmit-end interrupt vector numbers (0–127). VCRB is initialized to H'0000 by a reset. It is not initialized in standby mode.

Bit:	15	14	13	12	11	10	9	8
Bit name:	—	STXV6	STXV5	STXV4	STXV3	STXV2	STXV1	STXV0
Initial value:	0	0	0	0	0	0	0	0
R/W:	R	R/W	R/W	R/W	R/W	R/W	R/W	R/W

Bit:	7	6	5	4	3	2	1	0
Bit name:	—	STEV6	STEV5	STEV4	STEV3	STEV2	STEV1	STEV0
Initial value:	0	0	0	0	0	0	0	0
R/W:	R	R/W	R/W	R/W	R/W	R/W	R/W	R/W

- Bits 15, 7—Reserved: These bits always read 0. The write value should always be 0.
- Bits 14 to 8—Serial Communication Interface (SCI) Transmit-Data-Empty Interrupt Vector Number (STXV6–STXV0): These bits set the vector number for the serial communication interface (SCI) transmit-data-empty interrupt (TXI). There are seven bits, so the value can be set between 0 and 127.
- Bits 6 to 0—Serial Communication Interface (SCI) Transmit-End Interrupt Vector Number (STEV6–STEV0): These bits set the vector number for the serial communication interface (SCI) transmit-end interrupt (TEI). There are seven bits, so the value can be set between 0 and 127.

5.3.6 Vector Number Setting Register C (VCRC)

Vector number setting register C (VCRC) is a 16-bit read/write register that sets the FRT input-capture interrupt and output-compare interrupt vector numbers (0–127). VCRC is initialized to H'0000 by a reset. It is not initialized in standby mode.

Bit:	15	14	13	12	11	10	9	8
Bit name:	—	FICV6	FICV5	FICV4	FICV3	FICV2	FICV1	FICV0
Initial value:	0	0	0	0	0	0	0	0
R/W:	R	R/W	R/W	R/W	R/W	R/W	R/W	R/W

DataSheet4U.com

Bit:	7	6	5	4	3	2	1	0
Bit name:	—	FOCV6	FOCV5	FOCV4	FOCV3	FOCV2	FOCV1	FOCV0
Initial value:	0	0	0	0	0	0	0	0
R/W:	R	R/W	R/W	R/W	R/W	R/W	R/W	R/W

et4U.com

DataShe

- Bits 15, 7—Reserved: These bits always read 0. The write value should always be 0.
- Bits 14 to 8—Free-Running Timer (FRT) Input-Capture Interrupt Vector Number (FICV6–FICV0): These bits set the vector number for the free-running timer (FRT) input-capture interrupt (ICI). There are seven bits, so the value can be set between 0 and 127.
- Bits 6 to 0—Free-Running Timer (FRT) Output-Compare Interrupt Vector Number (FOCV6–FOCV0): These bits set the vector number for the free-running timer (FRT) output-compare interrupt (OCI). There are seven bits, so the value can be set between 0 and 127.

5.3.7 Vector Number Setting Register D (VCRD)

Vector number setting register D (VCRD) is a 16-bit read/write register that sets the FRT overflow interrupt vector number (0–127). VCRD is initialized to H'0000 by a reset. It is not initialized in standby mode.

Bit:	15	14	13	12	11	10	9	8
Bit name:	—	FOVV6	FOVV5	FOVV4	FOVV3	FOVV2	FOVV1	FOVV0
Initial value:	0	0	0	0	0	0	0	0
R/W:	R	R/W	R/W	R/W	R/W	R/W	R/W	R/W
Bit:	7	6	5	4	3	2	1	0
Bit name:	—	—	—	—	—	—	—	—
Initial value:	0	0	0	0	0	0	0	0
R/W:	R	R	R	R	R	R	R	R

- Bits 15, 7–0—Reserved: These bits always read 0. The write value should always be 0.
- Bits 14 to 8—Free-Running Timer (FRT) Overflow Interrupt Vector Number (FOVV6–FOVV0): These bits set the vector number for the free-running timer (FRT) overflow interrupt (OVI). There are seven bits, so the value can be set between 0 and 127.

Tables 5.6 and 5.7 show the relationship between on-chip peripheral module interrupts and interrupt vector number setting registers.

Table 5.6 Interrupt Request Sources and Vector Number Setting Registers (1)

Register	Bits	
	14–8	6–0
Vector number setting register WDT	Interval interrupt (WDT)	Compare-match interrupt (BSC)
Vector number setting register A	Receive-error interrupt (SCI)	Receive-data-full interrupt (SCI)
Vector number setting register B	Transmit-data-empty interrupt (SCI)	Transmit-end interrupt (SCI)
Vector number setting register C	Input-capture interrupt (FRT)	Output-compare interrupt (FRT)
Vector number setting register D	Overflow interrupt (FRT)	Reserved

As table 5.6 shows, two on-chip peripheral module interrupts are assigned to each register. Set the vector numbers by setting the corresponding 7-bit groups (bits 14 to 8 and bits 6 to 0) with values in the range of H'00 (0000000) to H'7F (1111111). H'00 is vector number 0 (the lowest); H'7F is vector number 127 (the highest). The vector table address is calculated by the following equation.

$$\text{Vector table address} = \text{VBR} + (\text{vector number} \times 4)$$

A reset initializes a vector number setting register to H'0000. They are not initialized in standby mode.

Table 5.7 lists functions for vector number setting registers DIV, DMAC0, and DMAC1. The vector number for DIV overflow interrupts is set in VCRDIV and the vector numbers for DMAC transfer-end interrupts are set in VCRDMA0 and VCRDMA1. See sections 9, Direct Memory Access Controller, and 10, Division Unit, for more details.

Table 5.7 Interrupt Request Sources and Vector Number Setting Registers (2)

Register	Setting Function
Vector number setting register DIV (VCRDIV)	Overflow interrupts for division unit
Vector number setting register DMAC0 (VCRDMA0)	Channel 0 transfer end interrupt for DMAC
Vector number setting register DMAC1 (VCRDMA1)	Channel 1 transfer end interrupt for DMAC

DataSheet4U.com

5.3.8 Interrupt Control Register (ICR)

ICR is a 16-bit register that sets the input signal detection mode of external interrupt input pin NMI and indicates the input signal level at the NMI pin. It also sets the IRL interrupt vector mode. A reset initializes ICR to H'8000 or H'0000 but the standby mode does not.

Bit:	15	14	13	12	11	10	9	8
Bit name:	NMIL	—	—	—	—	—	—	NMIE
Initial value:	0/1*	0	0	0	0	0	0	0
R/W:	R	R	R	R	R	R	R	R/W
Bit:	7	6	5	4	3	2	1	0
Bit name:	—	—	—	—	—	—	—	VECMD
Initial value:	0	0	0	0	0	0	0	0
R/W:	R	R	R	R	R	R	R	R/W

Note: * When NMI input is high: 1; when NMI input is low: 0

www.DataSheet4U.com

- Bit 15—NMI Input Level (NMIL): Sets the level of the signal input at the NMI pin. This bit can be read to determine the NMI pin level. This bit cannot be modified.

Bit 15: NMIL	Description
0	NMI input level is low
1	NMI input level is high

- Bits 14 to 9—Reserved: These bits always read 0. The write value should always be 0.
- Bit 8—NMI Edge Select (NMIE): Selects whether the falling or rising edge of the interrupt request signal to the NMI pin is detected.

Bit 8: NMIE	Description
0	Interrupt request is detected on falling edge of NMI input (Initial value)
1	Interrupt request is detected on rising edge of NMI input

- Bits 7 to 1—Reserved: These bits always read 0. The write value should always be 0.
- Bit 0—IRL Interrupt Vector Mode Select (VECMD): This bit selects auto-vector mode or external vector mode for IRL interrupt vector number setting. In auto-vector mode, an internally determined vector number is set. The IRL15 and IRL14 interrupt vector numbers are set to 71 and the IRL1 vector number is set to 64. In external vector mode, a value between 0 and 127 can be input as the vector number from the external vector number input pins (D7–D0).

Bit 0: VECMD	Description
0	Auto vector mode, vector number automatically set internally (Initial value)
1	External vector mode, vector number set by external input

5.4 Interrupt Operation

5.4.1 Interrupt Sequence

The sequence of interrupt operations (figure 5.5) is explained below:

1. The interrupt request sources send interrupt request signals to the interrupt controller.
2. The interrupt controller selects the highest-priority interrupt among the interrupt requests sent, according to the priority levels set in interrupt priority level setting registers A and B (IPRA and IPRB). Lower-priority interrupts are held pending. If two of these interrupts have the same priority level or if multiple interrupts occur within a single module, the interrupt with the highest default priority or the highest priority within its IPR setting unit (as indicated in table 5.4) is selected.
3. The interrupt controller compares the priority level of the selected interrupt request with the interrupt mask bits (I3–I0) in the CPU's status register (SR). If the request priority level is equal to or less than the level set in I3–I0, the request is held pending. If the request priority level is higher than the level in bits I3–I0, the interrupt controller accepts the interrupt and sends an interrupt request signal to the CPU.
4. The CPU detects the interrupt request sent from the interrupt controller when it decodes the next instruction to be executed. Instead of executing the decoded instruction, the CPU starts interrupt exception handling.
5. SR and PC are saved onto the stack.
6. The priority level of the accepted interrupt is copied to the interrupt mask level bits (I3 to I0) in the status register (SR).
7. When external vector mode is specified for the IRL interrupt, the vector number is read from the external vector number input pins (D7–D0).
8. The CPU reads the start address of the exception service routine from the exception vector table entry for the accepted interrupt, jumps to that address, and starts executing the program there. This jump is not a delayed branch.

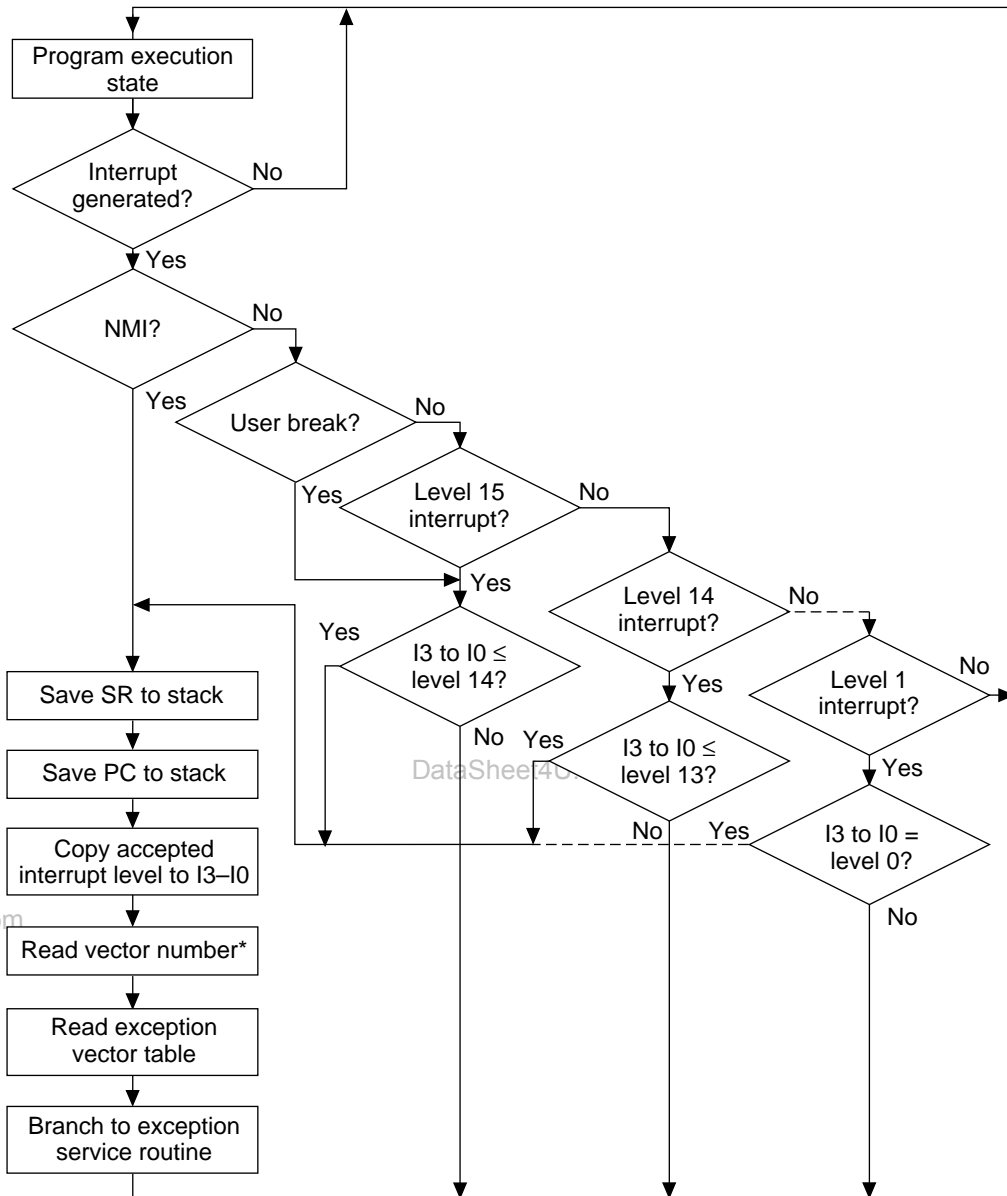

I3-I0: Status register interrupt mask bits.

Note: The vector number is only read from an external source when an external vector number is specified for the IRL interrupt vector number.

Figure 5.5 Interrupt Sequence Flowchart

5.4.2 Stack after Interrupt Exception Handling

Figure 5.6 shows the stack after interrupt exception handling.

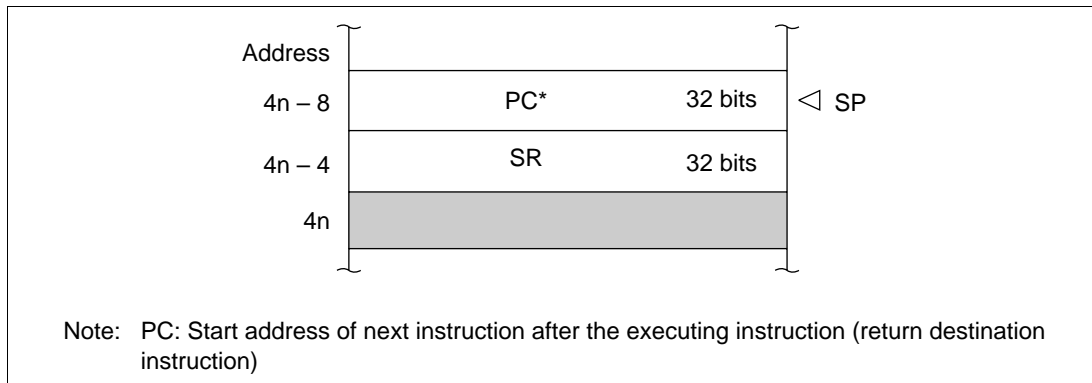

Figure 5.6 Stack after Interrupt Exception Handling

DataSheet4U.com

et4U.com

DataShee

DataSheet4U.com

www.DataSheet4U.com

5.5 Interrupt Response Time

Table 5.8 shows the interrupt response time, which is the time from the occurrence of an interrupt request until interrupt exception handling starts and fetching of the first instruction of the interrupt service routine begins. Figure 5.7 shows the pipeline when an IRL interrupt is accepted.

Table 5.8 Interrupt Response Time

Item	Number of States			Notes
	NMI	Peripheral Module	IRL	
Compare identified interrupt priority with SR mask level	2		5	—
Wait for completion of sequence currently being executed by CPU	$X (\geq 0)$			The longest sequence is for interrupt or address-error exception handling ($X = 4 + m1 + m2 + m3 + m4$). If an interrupt-masking instruction follows, however, the time may be even longer.
Time from interrupt exception handling (SR and PC saves and vector address fetch) until fetch of first instruction of exception service routine starts	$5 + m1 + m2 + m3$			—
Interrupt response	Total:	$7 + m1 + m2 + m3$	$10 + m1 + m2 + m3$	—
	Minimum:	10	13	—
	Maximum:	$11 + 2(m1 + m2 + m3) + m4$	$14 + 2(m1 + m2 + m3) + m4$	—

Note: m1–m4 are the number of states needed for the following memory accesses

m1: SR save (longword write)

m2: PC save (longword write)

m3: Vector address read (longword read)

m4: Fetch of first instruction of interrupt service routine

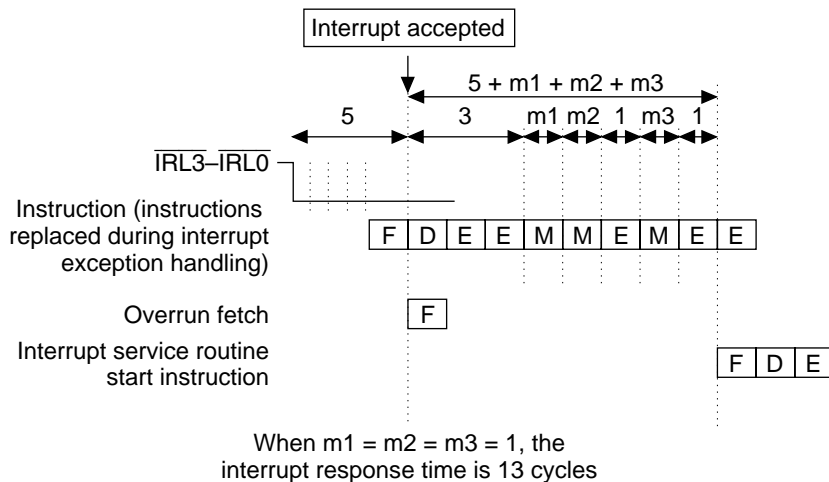

- F: Instruction fetch (instruction fetched from memory where program is stored)
- D: Instruction decoding (fetched instruction is decoded)
- E: Instruction execution (data operation and address calculation is performed according to the results of decoding)
- M: Memory access (data in memory is accessed)

Figure 5.7 Pipeline when an IRL Interrupt is Accepted

5.6 Sampling of Pins $\overline{\text{IRL3}}\text{--}\overline{\text{IRL0}}$

Signals on interrupt pins $\overline{\text{IRL3}}$ to $\overline{\text{IRL0}}$ pass through the noise canceler before being sent by the interrupt controller to the CPU as interrupt requests. The noise canceler cancels noise that changes in short cycles. The CPU samples the interrupt requests between executing instructions. During this period, the noise canceler output changes according to the noise-eliminated pin level, so the pin level must be held until the CPU samples it. This means that interrupt sources generally must not be cleared inside interrupt routines.

When an external vector is fetched, the interrupt source can also be cleared when the external vector fetch cycle is detected.

Figure 5.8 shows a block diagram of the interrupt response procedure. Figure 5.9 shows interrupt response timing.

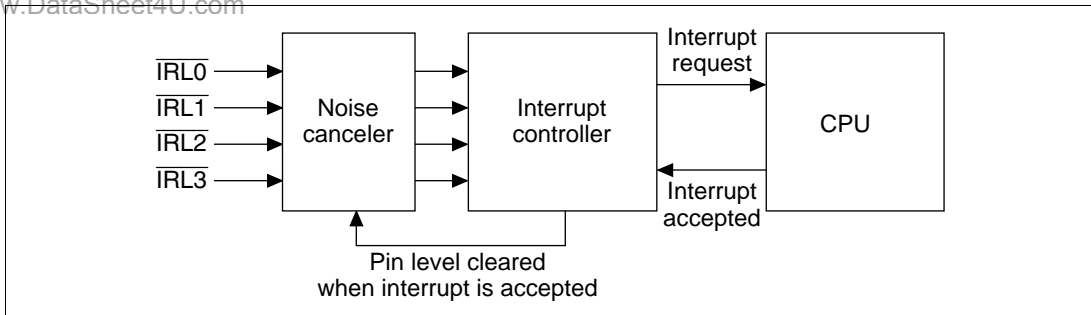

Figure 5.8 Interrupt Response Block Diagram

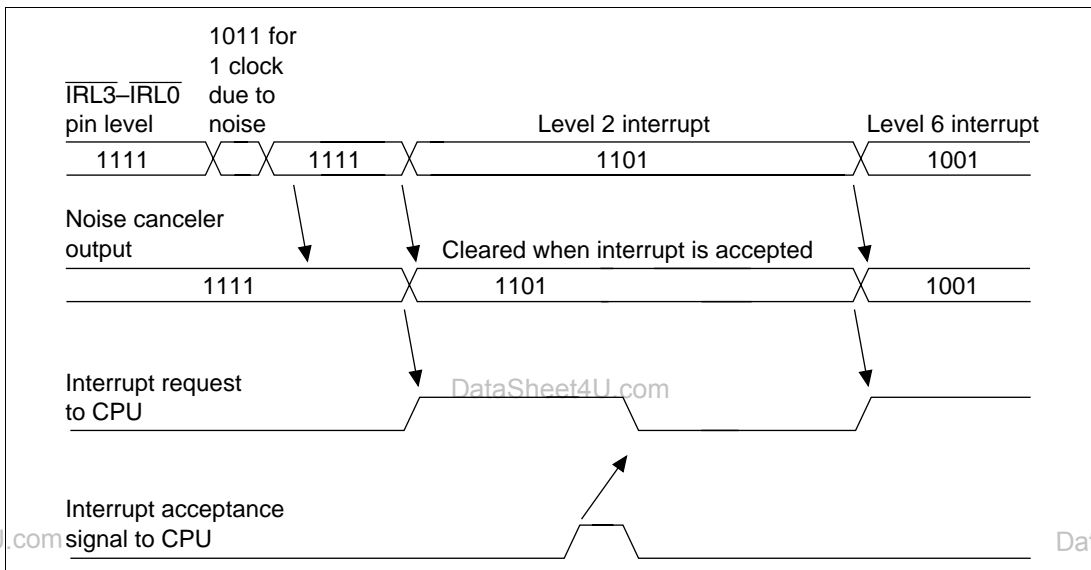

Figure 5.9 Interrupt Response Timing Chart

1. Do not execute module standby for modules that have the module-stop function when the possibility remains that an interrupt request may be output.
2. As shown in figure 5.10, the point at which the NMI request is cleared is the state following the decoding stage for the instruction replaced by the interrupt exception handling.

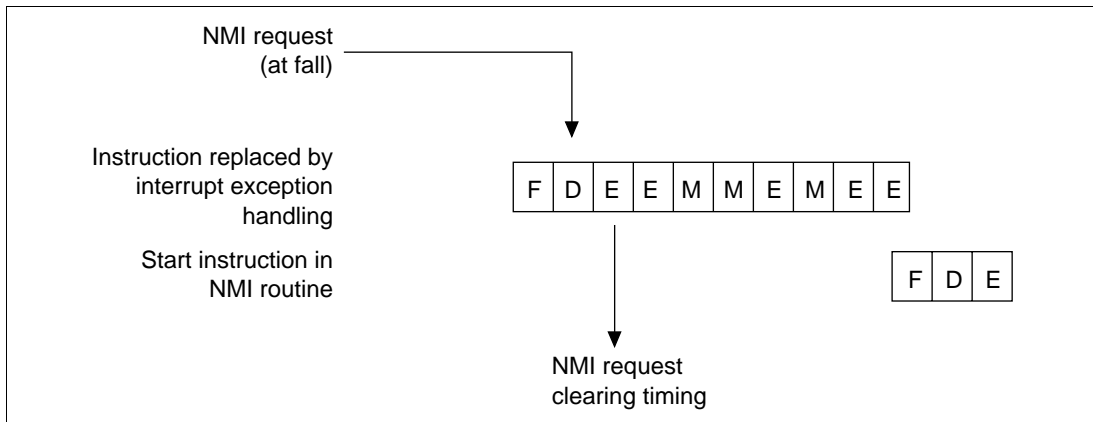

Figure 5.10 NMI Request Clearing Timing

3. Clearing Interrupt Sources:

External Interrupt Sources: When an interrupt source is cleared by writing to an I/O address, another instruction will be executed before the write can be completed because of the write buffer. To ensure that the next instruction is executed after the write is completed, read from the same address after the write to obtain total synchronization.

- Returning from interrupt handling with an RTE instruction: Figure 5.11 shows how a minimum interval of 1 cycle is required between the read instruction used for synchronization and the RTE instruction. A read instruction for synchronization and a minimum of 1 instruction should thus be executed between the source clear and the RTE instruction.
- Changing the level during interrupt handling: Figure 5.12 shows how a minimum interval of 4 cycles is required between the synchronization instruction and the LDC instruction when an LDC instruction is used to enable another overlapping interrupt by changing the SR value. A read instruction for synchronization and a minimum of 4 instructions should thus be executed between the source clear and the LDC instruction.

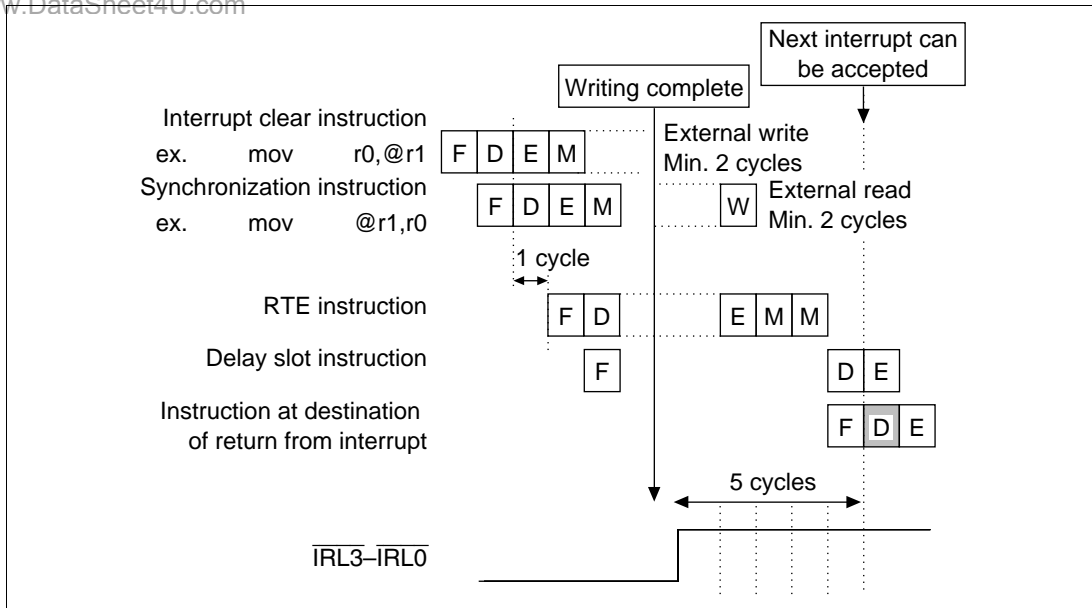

Figure 5.11 Pipeline Operation in Return with RTE

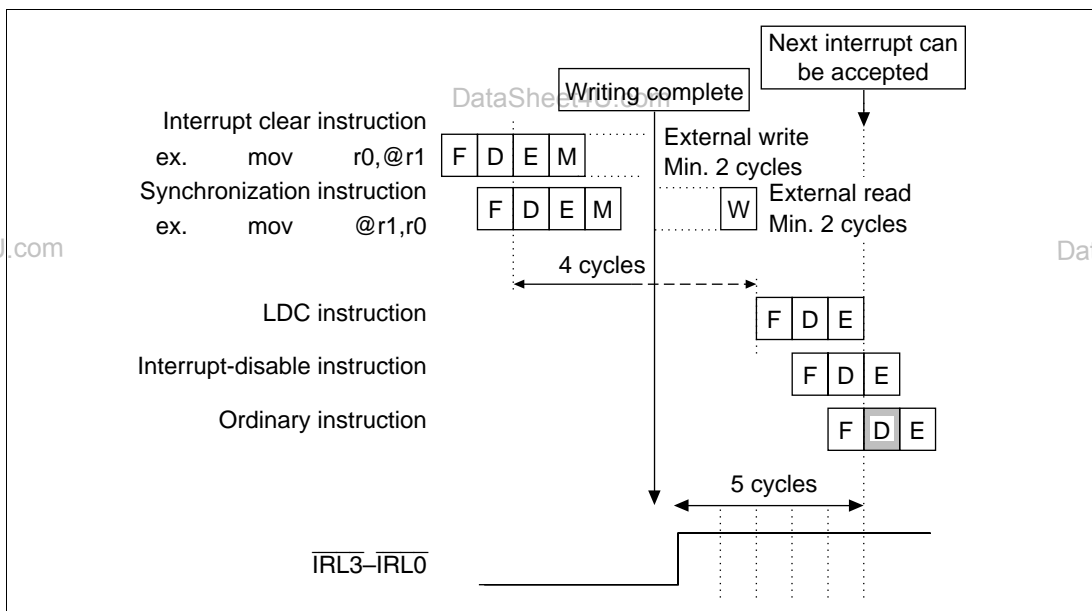

Figure 5.12 Pipeline Operation when Interrupts are Enabled by Modifying SR

On-Chip Interrupt Sources: Pipeline operation must be taken into account to ensure that the same interrupt does not occur again when the interrupt source is from an on-chip peripheral module. At least 2 cycles are required for the CPU to recognize that the interrupt is from an on-chip peripheral module. Two cycles are also required for the fact that there is no longer an interrupt request to be relayed.

- Returning from interrupt handling with an RTE instruction: Figure 5.13 shows how an extra cycle is required after the read instruction used for synchronization before interrupts are accepted, even when an RTE instruction is executed. A read instruction for synchronization should thus be executed between the source clear and the RTE instruction.
- Changing the level during interrupt handling: Figure 5.14 shows how a minimum interval of 2 cycles is required between the synchronization instruction and the LDC instruction when an LDC instruction is used to enable another overlapping interrupt by changing the SR value. A read instruction for synchronization and a minimum of 2 instructions should thus be executed between the source clear and the LDC instruction.

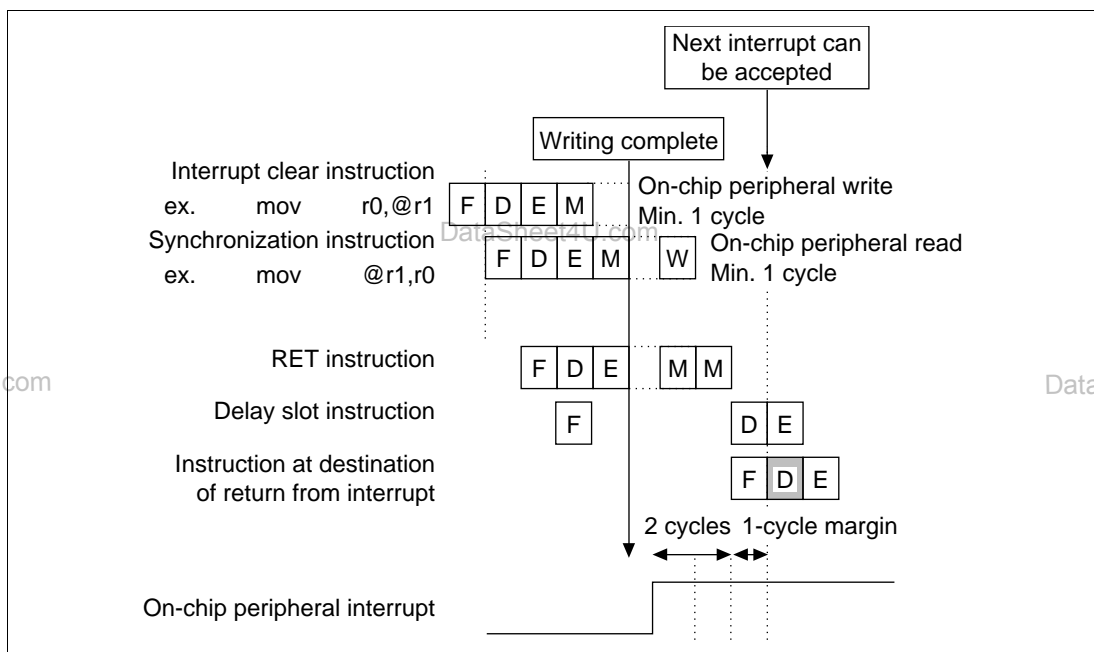

Figure 5.13 Pipeline Operation in Return with RTE

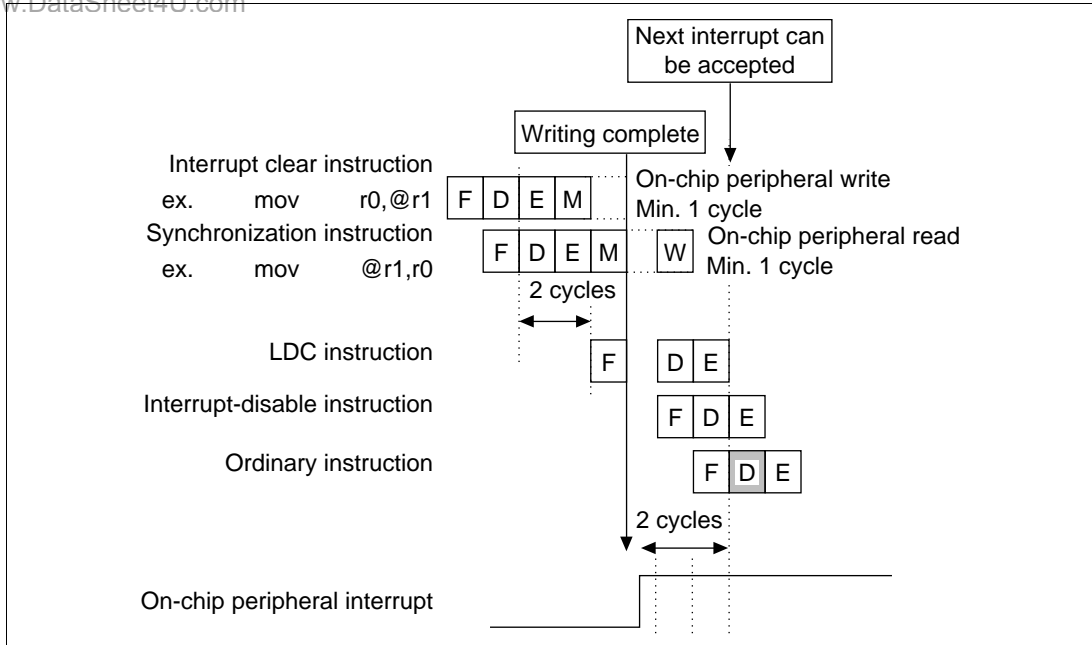

Figure 5.14 Pipeline Operation when Interrupts are Enabled by Changing the SR

Section 6 User Break Controller

6.1 Overview

The user break controller (UBC) provides functions that simplify program debugging. Break conditions are set in the UBC and a user break interrupt is generated according to the conditions of the bus cycle generated by the CPU, on-chip DMAC, or external bus master.

This function makes it easy to design an effective self-monitoring debugger, enabling the chip to debug programs without using an in-circuit emulator. The UBC can be set in an SH7000 series compatible mode, facilitating porting of monitoring programs that use other SH7000 series UBCs.

6.1.1 Features

The features of the user break controller are listed below:

- The following break compare conditions can be set: Two break channels (channel A, channel B). User break interrupts can be requested using either independent or sequential condition for the two channels (sequential breaks are channel A, then channel B).
 - Address
 - Data (channel B only)
 - Bus master: CPU cycle/DMA cycle/external bus cycle
 - Bus cycle: instruction fetch/data access
 - Read or write
 - Operand size: byte/word/longword
- User break interrupt generated upon satisfying break conditions. A user-designed user break interrupt exception handling routine can be run.
- Select breaking in the instruction fetch cycle before the instruction is executed, or after.
- Compatible with SH7000 series UBCs after a power-on reset.

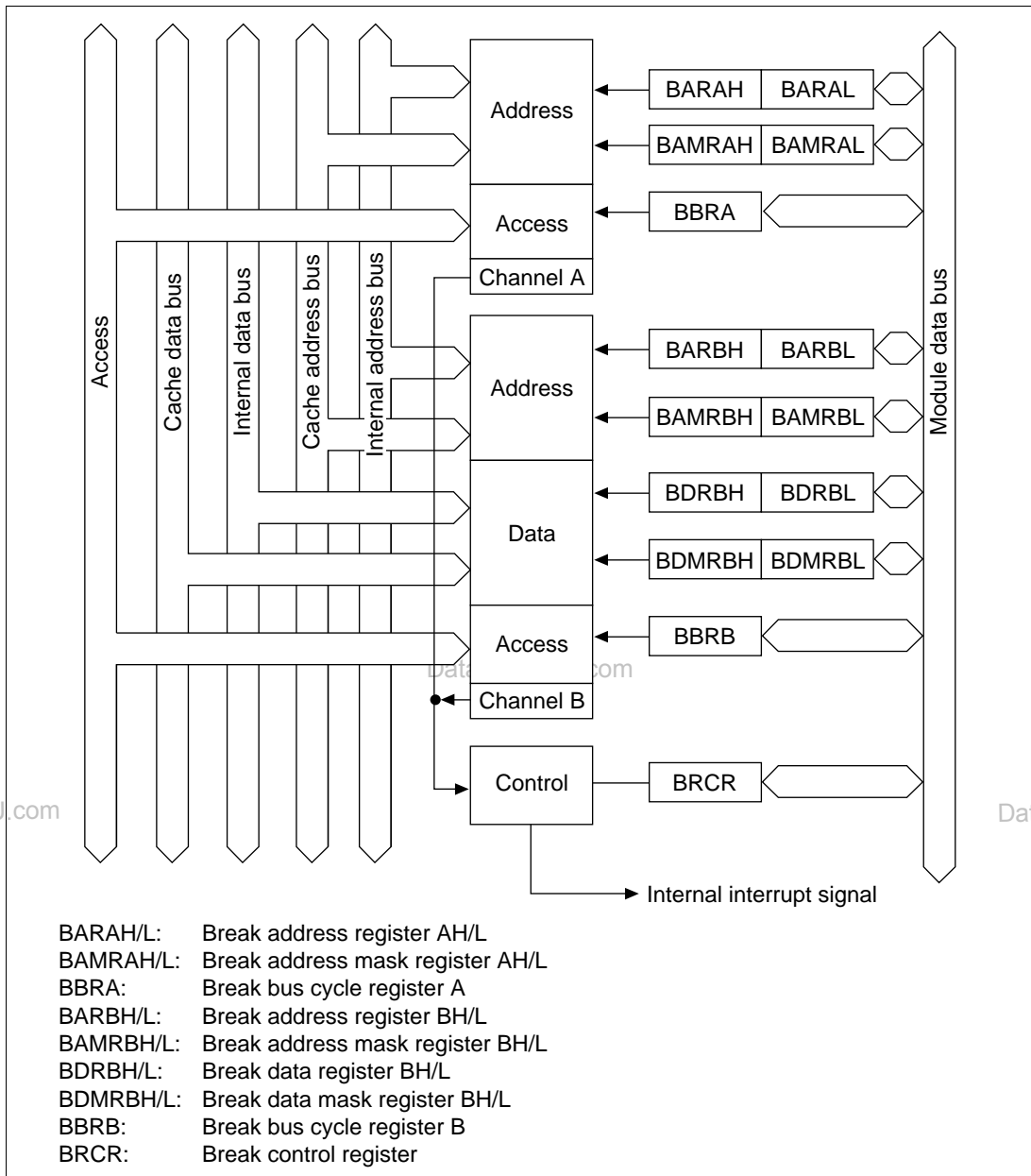

Figure 6.1 User Break Controller Block Diagram

6.1.3 Register Configuration

Table 6.1 Register Configuration

Name	Abbr.	R/W	Initial Value* ¹	Address	Access Size* ²
Break address register AH	BARAH	R/W	H'0000	H'FFFFFFF40	16 32
Break address register AL	BARAL	R/W	H'0000	H'FFFFFFF42	16
Break address mask register AH	BAMRAH	R/W	H'0000	H'FFFFFFF44	16 32
Break address mask register AL	BAMRAL	R/W	H'0000	H'FFFFFFF46	16
Break bus cycle register A	BBRA	R/W	H'0000	H'FFFFFFF48	16, 32
Break address register BH	BARBH	R/W	H'0000	H'FFFFFFF60	16 32
Break address register BL	BARBL	R/W	H'0000	H'FFFFFFF62	16
Break address mask register BH	BAMRBH	R/W	H'0000	H'FFFFFFF64	16 32
Break address mask register BL	BAMRBL	R/W	H'0000	H'FFFFFFF66	16
Break data register BH	BDRBH	R/W	H'0000	H'FFFFFFF70	16 32
Break data register BL	BDRBL	R/W	H'0000	H'FFFFFFF72	16
Break data mask register BH	BDMRBH	R/W	H'0000	H'FFFFFFF74	16 32
Break data mask register BL	BDMRBL	R/W	H'0000	H'FFFFFFF76	16
Break bus cycle register B	BBRB	R/W	H'0000	H'FFFFFFF68	16, 32
Break control register	BRCR	R/W	H'0000	H'FFFFFFF78	16, 32

Notes: 1. Initialized by a power-on reset. Values held in standby mode. Value undefined after a manual reset.

2. Byte access not permitted.

SH7000 Series UBC Compatibility: When set in the SH7000-series-compatible mode, SH7000 series UBC registers on the SH7604 are as shown in table 6.2.

Table 6.2 SH7000 Series and SH7604 UBCs

SH7000 Series		SH7604	
Name	Abbr.	Name	Abbr.
Break address register H	BARH	Break address register AH	BARAH
Break address register L	BARL	Break address register AL	BARAL
Break address mask register H	BAMRH	Break address mask register AH	BAMRAH
Break address mask register L	BAMRL	Break address mask register AL	BAMRAL
Break bus cycle register	BBR	Break bus cycle register A	BBRA

6.2 Register Descriptions

6.2.1 Break Address Register A (BARA)

BARAH:

Bit:	15	14	13	12	11	10	9	8
Bit name:	BAA31	BAA30	BAA29	BAA28	BAA27	BAA26	BAA25	BAA24
Initial value:	0	0	0	0	0	0	0	0
R/W:	R/W	R/W	R/W	R/W	R/W	R/W	R/W	R/W

Bit:	7	6	5	4	3	2	1	0
Bit name:	BAA23	BAA22	BAA21	BAA20	BAA19	BAA18	BAA17	BAA16
Initial value:	0	0	0	0	0	0	0	0
R/W:	R/W	R/W	R/W	R/W	R/W	R/W	R/W	R/W

BARAL:

Bit:	15	14	13	12	11	10	9	8
Bit name:	BAA15	BAA14	BAA13	BAA12	BAA11	BA10	BAA9	BAA8
Initial value:	0	0	0	0	0	0	0	0
R/W:	R/W	R/W	R/W	R/W	R/W	R/W	R/W	R/W

Bit:	7	6	5	4	3	2	1	0
Bit name:	BAA7	BAA6	BAA5	BAA4	BAA3	BAA2	BAA1	BAA0
Initial value:	0	0	0	0	0	0	0	0
R/W:	R/W	R/W	R/W	R/W	R/W	R/W	R/W	R/W

The two break address registers A—break address register AH (BARAH) and break address register AL (BARAL)—together form a single group. Both are 16-bit read/write registers. BARAH stores the upper bits (bits 31 to 16) of the address of the channel A break condition, while BARAL stores the lower bits (bits 15 to 0). A power-on reset initializes both BARAH and BARAL to H'0000. Their values are undefined after a manual reset.

- BARAH Bits 15 to 0—Break Address A 31 to 16 (BAA31 to BAA16): These bits store the upper bit values (bits 31 to 16) of the address of the channel A break condition.
- BARAL Bits 15 to 0—Break Address A 15 to 0 (BAA15 to BAA0): These bits store the lower bit values (bits 15 to 0) of the address of the channel A break condition.

6.2.2 Break Address Mask Register A (BAMRA)

BAMRAH:

Bit:	15	14	13	12	11	10	9	8
Bit name:	BAMA31	BAMA30	BAMA29	BAMA28	BAMA27	BAMA26	BAMA25	BAMA24
Initial value:	0	0	0	0	0	0	0	0
R/W:	R/W	R/W	R/W	R/W	R/W	R/W	R/W	R/W
Bit:	7	6	5	4	3	2	1	0
Bit name:	BAMA23	BAMA22	BAMA21	BAMA20	BAMA19	BAMA18	BAMA17	BAMA16
Initial value:	0	0	0	0	0	0	0	0
R/W:	R/W	R/W	R/W	R/W	R/W	R/W	R/W	R/W

BAMRAL:

Bit:	15	14	13	12	11	10	9	8
Bit name:	BAMA15	BAMA14	BAMA13	BAMA12	BAMA11	BAMA10	BAMA9	BAMA8
Initial value:	0	0	0	0	0	0	0	0
R/W:	R/W	R/W	R/W	R/W	R/W	R/W	R/W	R/W
Bit:	7	6	5	4	3	2	1	0
Bit name:	BAMA7	BAMA6	BAMA5	BAMA4	BAMA3	BAMA2	BAMA1	BAMA0
Initial value:	0	0	0	0	0	0	0	0
R/W:	R/W	R/W	R/W	R/W	R/W	R/W	R/W	R/W

The two break address mask registers A (BAMRA)—break address mask register AH (BAMRAH) and break address mask register AL (BAMRAL)—together form a single group. Both are 16-bit read/write registers. BAMRAH determines which of the bits in the break address set in BARAH are masked. BAMRAL determines which of the bits in the break address set in BARAL are masked. A power-on reset initializes BAMRAH and BAMRAL to H'0000. Their values are undefined after a manual reset.

- BAMRAH Bits 15 to 0—Break Address Mask A 31 to 16 (BAMA31 to BAMA16): These bits specify whether bits 31–16 (BAA31 to BAA16) of the channel A break address set in BARAH are masked.
- BAMRAL Bits 15 to 0—Break Address Mask A 15 to 0 (BAMA15 to BAMA0): These bits specify whether bits 15–0 (BAA15 to BAA0) of the channel A break address set in BARAL are masked.

0	Channel A break address BAA is included in the break conditions (Initial value)
1	Channel A break address BAA is masked and therefore not included in the break conditions

n = 31 to 0

6.2.3 Break Bus Cycle Register A (BBRA)

Bit:	15	14	13	12	11	10	9	8
Bit name:	—	—	—	—	—	—	—	—
Initial value:	0	0	0	0	0	0	0	0
R/W:	R	R	R	R	R	R	R	R

Bit:	7	6	5	4	3	2	1	0
Bit name:	CPA1	CPA0	IDA1	IDA0	RWA1	RWA0	SZA1	SZA0
Initial value:	0	0	0	0	0	0	0	0
R/W:	R/W	R/W	R/W	R/W	R/W	R/W	R/W	R/W

The break bus cycle register A (BBRA) is a 16-bit read/write register that selects the following four channel A break conditions:

1. CPU cycle/peripheral cycle
2. Instruction fetch/data access
3. Read/write
4. Operand size

A power-on reset initializes BBRA to H'0000. Its value is undefined after a manual reset.

- Bits 15 to 8—Reserved: These bits always read 0. The write value should always be 0.
- Bits 7 and 6—CPU Cycle/Peripheral Cycle Select A (CPA1, CPA0): These bits select whether to break channel A on a CPU and/or peripheral bus cycle. Peripheral cycles are defined as on-chip DMAC bus cycles, and external bus master bus cycles when the bus is released. When the peripheral cycle setting is made, on-chip DMAC cycles are always included in the break conditions; however, external bus master cycles can be included or excluded, according to the setting of the EBBE bit in the BRCCR register.

Bit 7: CPA1	Bit 6: CPA0	Description
0	0	No channel A user break interrupt occurs (Initial value)
	1	Break only on CPU cycles
1	0	Break only on peripheral cycles
	1	Break on both CPU and peripheral cycles

- Bits 5 and 4—Instruction Fetch/Data Access Select A (IDA1, IDA0): These bits select whether to break channel A on instruction fetch and/or data access cycles.

Bit 5: IDA1	Bit 4: IDA0	Description
0	0	No channel A user break interrupt occurs (Initial value)
	1	Break only on instruction fetch cycles
1	0	Break only on data access cycles
	1	Break on both instruction fetch and data access cycles

- Bits 3 and 2—Read/Write Select A (RWA1, RWA0): These bits select whether to break channel A on read and/or write cycles.

Bit 3: RWA1	Bit 2: RWA0	Description
0	0	No channel A user break interrupt occurs (Initial value)
	1	Break only on read cycles
1	0	Break only on write cycles
	1	Break on both read and write cycles

et4U.com

DataShee

- Bits 1 and 0—Operand Size Select A (SZA1, SZA0): These bits select bus cycle operand size as a channel A break condition.

Bit 1: SZA1	Bit 0: SZA0	Description
0	0	Operand size is not a break condition (Initial value)
	1	Break on byte access
1	0	Break on word access
	1	Break on longword access

Note: When breaking on an instruction fetch, set the SZA0 bit to 0. All instructions are considered to be word-size accesses (instruction fetches are always longword). Operand size is word for instructions or determined by the operand size specified for the CPU/DMAC data access. It is not determined by the bus width of the space being accessed.

6.2.4 Break Address Register B (BARB)

The channel B break address register has the same bit configuration as BARA.

6.2.5 Break Address Mask Register B (BAMRB)

The channel B break address mask register has the same bit configuration as BAMRA.

6.2.6 Break Data Register B (BDRB)

BDRBH:

Bit:	15	14	13	12	11	10	9	8
Bit name:	BDB31	BDB30	BDB29	BDB28	BDB27	BDB26	BDB25	BDB24
Initial value:	0	0	0	0	0	0	0	0
R/W:	R/W	R/W	R/W	R/W	R/W	R/W	R/W	R/W
Bit:	7	6	5	4	3	2	1	0
Bit name:	BDB23	BDB22	BDB21	BDB20	BDB19	BDB18	BDB17	BDB16
Initial value:	0	0	0	0	0	0	0	0
R/W:	R/W	R/W	R/W	R/W	R/W	R/W	R/W	R/W

BDRBL:

Bit:	15	14	13	12	11	10	9	8
Bit name:	BDB15	BDB14	BDB13	BDB12	BDB11	BDB10	BDB9	BDB8
Initial value:	0	0	0	0	0	0	0	0
R/W:	R/W	R/W	R/W	R/W	R/W	R/W	R/W	R/W
Bit:	7	6	5	4	3	2	1	0
Bit name:	BDB7	BDB6	BDB5	BDB4	BDB3	BDB2	BDB1	BDB0
Initial value:	0	0	0	0	0	0	0	0
R/W:	R/W	R/W	R/W	R/W	R/W	R/W	R/W	R/W

The two break data registers B (BDRB)—break data register BH (BDRBH) and break data register BL (BDRBL)—together form a single group. Both are 16-bit read/write registers. BDRBH specifies the upper half (bits 31–16) of the data that is the break condition for channel B, while BDRBL specifies the lower half (bits 15–0). A power-on reset initializes BDRBH and BDRBL to H'0000. Their values are undefined after a manual reset.

- **BDRBH Bits 15 to 0**—Break Data B 31 to 16 (BDB31 to BDB16): These bits store the upper half (bits 31–16) of the data that is the break condition for break channel B.
- **BDRBL Bits 15 to 0**—Break Data B 15 to 0 (BDB15 to BDB0): These bits store the lower half (bits 15–0) of the data that is the break condition for break channel B.

6.2.7 Break Data Mask Register B (BDMRB)

BDMRBH:

Bit:	15	14	13	12	11	10	9	8
Bit name:	BDMB31	BDMB30	BDMB29	BDMB28	BDMB27	BDMB26	BDMB25	BDMB24
Initial value:	0	0	0	0	0	0	0	0
R/W:	R/W	R/W	R/W	R/W	R/W	R/W	R/W	R/W
Bit:	7	6	5	4	3	2	1	0
Bit name:	BDMB23	BDMB22	BDMB21	BDMB20	BDMB19	BDMB18	BDMB17	BDMB16
Initial value:	0	0	0	0	0	0	0	0
R/W:	R/W	R/W	R/W	R/W	R/W	R/W	R/W	R/W

BDMRBL:

Bit:	15	14	13	12	11	10	9	8
Bit name:	BDMB15	BDMB14	BDMB13	BDMB12	BDMB11	BDMB10	BDMB9	BDMB8
Initial value:	0	0	0	0	0	0	0	0
R/W:	R/W	R/W	R/W	R/W	R/W	R/W	R/W	R/W
Bit:	7	6	5	4	3	2	1	0
Bit name:	BDMB7	BDMB6	BDMB5	BDMB4	BDMB3	BDMB2	BDMB1	BDMB0
Initial value:	0	0	0	0	0	0	0	0
R/W:	R/W	R/W	R/W	R/W	R/W	R/W	R/W	R/W

The two break data mask registers B (BDMRB)—break data mask register BH (BDMRBH) and break data mask register BL (BDMRBL)—together form a single group. Both are 16-bit read/write registers. BDMRBH determines which of the bits in the break address set in BDRBH are masked. BDMRBL determines which of the bits in the break address set in BDRBL are masked. A power-on reset initializes BDMRBH and BDMRBL to H'0000. Their values are undefined after a manual reset.

- **BDMRBH Bits 15 to 0**—Break Data Mask B 31 to 16 (BDMB31 to BDMB16): These bits specify whether bits B 31–16 (BDB31 to BDB16) of the channel B break data set in BDRBH are masked.
- **BDMRBL Bits 15 to 0**—Break Data Mask B 15 to 0 (BDMB15 to BDMB0): These bits specify whether bits B 15–0 (BDB15 to BDB0) of the channel B break data set in BDRBL are masked.

Bits 31–0: BDMBn	Description
0	Channel B break address bit BDBn is included in the break condition (Initial value)
1	Channel B break address bit BDBn is masked and therefore not included in the break condition

n = 31 to 0

- Notes:
1. When the data bus value is included in the break conditions, specify the operand size.
 2. For word data, set in bits 15–0 of BDRB and BDMRB. For byte data, set the same data in bits 0–7 and bits 8–15 of BDRB and BDMRB.
 3. External bus master bus cycles when the bus is released cannot be included in the data bus conditions.

6.2.8 Bus Break Register B (BBRB)

The channel B bus break register has the same bit configuration as BBRA.

6.2.9 Break Control Register (BRCR)

Bit:	15	14	13	12	11	10	9	8
Bit name:	CMFCA	CMFPA	EBBE	UMD	—	PCBA	—	—
Initial value:	0	0	0	0	0	0	0	0
R/W:	R/W	R/W	R/W	R/W	R	R/W	R	R
Bit:	7	6	5	4	3	2	1	0
Bit name:	CMFCB	CMFPB	—	SEQ	DBEB	PCBB	—	—
Initial value:	0	0	0	0	0	0	0	0
R/W:	R/W	R/W	R	R/W	R	R/W	R	R

1. Determines whether to use channels A and B as two independent channels or as sequential conditions.
2. Selects SH7000 series compatible mode or SH7604 mode.
3. Selects whether to break before or after instruction execution during the instruction fetch cycle.
4. Enables or disables the external bus.
5. Selects whether to include the data bus in channel B comparison conditions.

It also has a condition-match flag that is set when conditions match. A power-on reset initializes BRCR to H'0000. Its value is undefined after a manual reset.

- Bit 15—CPU Condition-Match Flag A (CMFCA): Set to 1 when CPU bus cycle conditions included in the break conditions set for channel A are met. Not cleared to 0.

Bit 15: CMFCA	Description
0	Channel A CPU cycle conditions do not match, no user break interrupt generated (Initial value)
1	Channel A CPU cycle conditions have matched, user break interrupt generated

- Bit 14—Peripheral Condition-Match Flag A (CMFPA): Set to 1 when peripheral bus cycle conditions (on-chip DMAC, or external bus cycle when external bus breaks are enabled) included in the break conditions set for channel A are met. Not cleared to 0.

Bit 14: CMFPA	Description
0	Channel A peripheral cycle conditions do not match, no user break interrupt generated (Initial value)
1	Channel A peripheral cycle conditions have matched, user break interrupt generated

- Bit 13—External Bus Break Enable (EBBE): Monitors the external bus master's address bus when the bus is released, and includes the external bus master's bus cycle in the bus cycle select conditions (CPA1, CPB1). External bus breaks are possible in the total master mode and total slave mode. When the external bus break is enabled, set CPA1 in BBRA or CPB1 in BBRB.

Bit 13: EBBE	Description
0	Chip-external bus cycle not included in break conditions (Initial value)
1	Chip-external bus cycle included in break conditions

- Bit 12—UBC Mode (UMD): Selects SH7000 series-compatible mode or SH7604 mode.

Bit 12: UMD	Description
0	Compatible mode for SH7000 Series UBCs (Initial value)
1	SH7604 mode

- Bit 11—Reserved: This bit always reads 0. The write value should always be 0.
- Bit 10—PC Break Select A (PCBA): Selects whether to place the channel A break in the instruction fetch cycle before or after instruction execution.

Bit 10: PCBA	Description
0	Places the channel A instruction fetch cycle break before instruction execution (Initial value)
1	Places the channel A instruction fetch cycle break after instruction execution

- Bits 9 and 8—Reserved: These bits always read 0. The write value should always be 0.
- Bit 7—CPU Condition-Match Flag B (CMFCB): Set to 1 when CPU bus cycle conditions included in the break conditions set for channel B are met. Not cleared to 0 (once set, it must be cleared by a write before it can be used again).

Bit 7: CMFCB	Description
0	Channel B CPU cycle conditions do not match, no user break interrupt generated (Initial value)
1	Channel B CPU cycle conditions have matched, user break interrupt generated

- Bit 6—Peripheral Condition-Match Flag B (CMFPB): Set to 1 when peripheral bus cycle conditions (on-chip DMAC, or external bus cycle when external bus monitoring is enabled) included in the break conditions set for channel B are met. Not cleared to 0 (once set, it must be cleared by a write before it can be used again).

Bit 6: CMFPB	Description
0	Channel B peripheral cycle conditions do not match, no user break interrupt generated (Initial value)
1	Channel B peripheral cycle conditions have matched, user break interrupt generated

- Bit 5—Reserved: This bit always reads 0. The write value should always be 0.
- Bit 4—Sequence Condition Select (SEQ): Selects whether to handle the channel A and B conditions independently or sequentially.

Bit 4: SEQ	Description
0	Channel A and B conditions compared independently (Initial value)
1	Channel A and B conditions compared sequentially (channel A, then channel B)

- Bit 3—Data Break Enable B (DBEB): Selects whether to include data bus conditions in the channel B break conditions.

Bit 3: DBEB	Description
0	Data bus conditions not included in the channel B conditions (Initial value)
1	Data bus conditions included in the channel B conditions

- Bit 2—Instruction Break Select (PCBB): Selects whether to place the channel B instruction fetch cycle break before or after instruction execution.

Bit 2: PCBB	Description
0	Places the channel B instruction fetch cycle break before instruction execution (Initial value)
1	Places the channel B instruction fetch cycle break after instruction execution

- Bits 1 and 0—Reserved: These bits always read 0. The write value should always be 0.

6.3.1 Flow of the User Break Operation

The flow from setting of break conditions to user break interrupt exception handling is described below:

1. The break addresses are set in the break address registers (BARA, BARB), the masked addresses are set in the break address mask registers (BAMRA, BAMRB), the break data is set in the break data register (BDRB), and the masked data is set in the break data mask register (BDMRB). The breaking bus conditions are set in the break bus cycle registers (BBRA, BBRB). The three groups of the BBRA and BBRB registers—CPU cycle/peripheral cycle select, instruction fetch/data access select, and read/write select—are each set. No user break interrupt will be generated if even one of these groups is set with 00. The conditions are set in the respective bits of the BRCR register.
2. When the set conditions are satisfied, the UBC sends a user break interrupt request to the interrupt controller. When conditions match, the CPU condition match flags (CMFCA, CMFCB) and peripheral condition match flags (CMFPA, CMFPB) for the respective channels are set.
3. The interrupt controller checks the user break interrupt's priority level. The user break interrupt has priority level 15, so it is accepted only if the interrupt mask level in bits I3–I0 in the status register (SR) is 14 or lower. When the I3–I0 bit level is 15, the user break interrupt cannot be accepted but it is held pending until user break interrupt exception handling can be carried out. Section 5, Interrupt Controller, describes the handling of priority levels in greater detail.
4. When the priority is found to permit acceptance of the user break interrupt, the CPU starts user break interrupt exception handling.
5. The appropriate condition match flag (CMFCA, CMFPA, CMFCB, CMFPB) can be used to check if the set conditions match or not. The flags are set by the matching of the conditions, but they are not reset. 0 must first be written to them before they can be used again.

6.3.2 Break on Instruction Fetch Cycle

1. When CPU/instruction fetch/read/word is set in the break bus cycle registers (BBRA/BBRB), the break condition becomes the CPU's instruction fetch cycle. Whether it breaks before or after the execution of the instruction can then be selected for the appropriate channel with the PCBA/PCBB bit in the break control register (BRCR).
2. The instruction fetch cycle always fetches 32 bits (two instructions). Only one bus cycle occurs, but breaks can be placed on each instruction individually by setting the respective addresses in the break address registers (BARA, BARB).

3. An instruction set for a break before execution breaks when it is confirmed that the instruction has been fetched and will be executed. This means this feature cannot be used on instructions fetched by overrun (instructions fetched at a branch or during an interrupt transition, but not to be executed). When this kind of break is set for the delay slot of a delayed branch instruction or an instruction following an interrupt-disabled instruction, such as LDC, the interrupt is generated prior to execution of the first instruction at which the interrupt is subsequently then accepted.
4. When the condition stipulates after execution, the instruction set with the break condition is executed and then the interrupt is generated prior to the execution of the next instruction. As with pre-execution breaks, this cannot be used with overrun fetch instructions. When this kind of break is set for a delayed branch instruction or an interrupt-disabled instruction, such as LDC, the interrupt is generated at the first instruction at which the interrupt is subsequently accepted.
5. When an instruction fetch cycle is set for channel B, break data register B (BDRB) is ignored. There is thus no need to set break data for an instruction fetch cycle break.

6.3.3 Break on Data Access Cycle

1. The memory cycles in which CPU data access breaks occur are: memory cycles from instructions, and stacking and vector reads during exception handling. These breaks cannot be used in dummy cycles for single reads of synchronous DRAM.
2. The relationship between the data access cycle address and the comparison condition for operand size are shown in table 6.3. This means that when address H'00001003 is set without specifying the size condition, for example, the bus cycle in which the break condition is satisfied is as follows (where other conditions are met):

Longword access at address H'00001000

Word access at address H'00001002

Byte access at address H'00001003

Table 6.3 Data Access Cycle Addresses and Operand Size Comparison Conditions

Access Size	Address Compared
Longword	Break address register bits 31–2 compared with address bus bits 31–2
Word	Break address register bits 31–1 compared with address bus bits 31–1
Byte	Break address register bits 31–0 compared with address bus bits 31–0

3. When the data value is included in the break conditions on channel B:

When the data value is included in the break conditions, specify either longword, word, or byte as the operand size in the break bus cycle registers (BBRA, BBRB). When data values are included in break conditions, a break interrupt is generated when the address conditions and data conditions both match. To specify byte data for this case, set the same data in the two

bytes at bits 15–8 and bits 7–0 of the break data register B (BDRB) and break data mask register B (BDMRB). When word or byte is set, bits 31–16 of BDRB and BDMRB are ignored.

6.3.4 Break on External Bus Cycle

1. Enable the external bus break enable bit (the EBBE bit in BRCR) to generate a break for a bus cycle generated by the external bus master when the bus is released. External bus cycle breaks can be used in total master mode or total slave mode.
2. Address and read/write can be set for external buses, but size cannot be specified. Setting sizes of byte/word/longword will be ignored. Also, no distinction can be made between instruction fetch and data access for external bus cycles. All cycles are considered data access cycles, so set 1 in bits IDA1 and IDB1 in BBRA and BBRB.
3. External input of addresses uses A26–A0, so set bits 31–27 of the break address registers (BARA, BARB) to 0, or set bits 31–27 of the break address mask registers (BAMRA, BAMRB) to 1 to mask the addresses not input.
4. When the conditions set for the external bus cycle are satisfied, the CMFPA and CMFPB bits are set for the respective channels.

6.3.5 Program Counter (PC) Values Saved

1. Break on Instruction Fetch (Before Execution): The program counter (PC) value saved to the stack in user break interrupt exception handling is the address that matches the break condition. The user break interrupt is generated before the fetched instruction is executed. If a break condition is set on an instruction that follows an interrupt-disabled instruction, however, the break occurs before execution of the instruction at which the next interrupt is accepted, so the PC value saved is the address of the break.
2. Break on Instruction Fetch (After Execution): The program counter (PC) value saved to the stack in user break interrupt exception handling is the address executed after the one that matches the break condition. The fetched instruction is executed and the user break interrupt generated before the next instruction is executed. If a break condition is set on an interrupt-disabled instruction, the break occurs before execution of the instruction at which the next interrupt is accepted, so the PC value saved is the address of the break.
3. Break on Data Access (CPU/Peripheral): The program counter (PC) value is the start address of the next instruction after the last instruction executed before the user break exception handling started. When data access (CPU/peripheral) is set as a break condition, the place where the break will occur cannot be specified exactly. The break will occur at an instruction fetched close to where the data access that is to receive the break occurs.

6.3.6 Example of Use

Break on a CPU Instruction Fetch Bus Cycle:

- A. Register settings: BARA = H'00000404, BAMRA = H'00000000, BBRA = H'0054
 BARB = H'00008010, BAMRB = H'00000006, BBRB = H'0054
 BDRB = H'00000000, BDMRB = H'00000000
 BRRCR = H'1400

Conditions set (channel A/channel B independent mode):

Channel A: Address = H'00000404, address mask H'00000000
 Bus cycle = CPU, instruction fetch (after execution), read
 (operand size not included in conditions)

Channel B: Address = H'00008010, address mask H'00000006
 Data H'00000000, data mask H'00000000
 Bus cycle = CPU, instruction fetch (before execution), read
 (operand size not included in conditions)

A user break will occur after the instruction at address H'00000404 is executed, or a user break will be generated before the execution of the instruction at address H'00008010–H'00008016.

- B. Register settings: BARA = H'00037226, BAMRA = H'00000000, BBRA = H'0056
 BARB = H'0003722E, BAMRB = H'00000000, BBRB = H'0056
 BDRB = H'00000000, BDMRB = H'00000000
 BRRCR = H'1010

Conditions set (channel A → channel B sequential mode):

Channel A: Address = H'00037226, address mask H'00000000
 Bus cycle = CPU, instruction fetch (before execution), read, word

Channel B: Address = H'0003722E, address mask H'00000000
 Data H'00000000, data mask H'00000000
 Bus cycle = CPU, instruction fetch (before execution), read, word

The instruction at address H'00037226 will be executed and then a user break interrupt will occur before the instruction at address H'0003722E is executed.

C. Register settings: BARA = H'00027128, BAMRA = H'00000000, BBRA = H'005A
 BARB = H'00031415, BAMRB = H'00000000, BBRB = H'0054
 BDRB = H'00000000, BDMRB = H'00000000
 BRCCR = H'1000

Conditions set (channel A/channel B independent mode):

Channel A: Address = H'00027128, address mask H'00000000
 Bus cycle = CPU, instruction fetch (before execution), write, word

Channel B: Address = H'00031415, address mask H'00000000
 Data H'00000000, data mask H'00000000
 Bus cycle = CPU, instruction fetch (before execution), read
 (operand size not included in conditions)

A user break interrupt is not generated for channel A since the instruction fetch is not a write cycle. A user break interrupt is not generated for channel B because the instruction fetch is for an odd address.

D. Register settings: BARA = H'00037226, BAMRA = H'00000000, BBRA = H'005A
 BARB = H'0003722E, BAMRB = H'00000000, BBRB = H'0056
 BDRB = H'00000000, BDMRB = H'00000000
 BRCCR = H'1010

DataSheet4U.com

Conditions set (channel A → channel B sequential mode):

Channel A: Address = H'00037226, address mask H'00000000
 Bus cycle = CPU, instruction fetch (before execution), write, word

Channel B: Address = H'0003722E, address mask H'00000000
 Data H'00000000
 Data mask H'00000000
 Bus cycle = CPU, instruction fetch (before execution), read, word

The break for channel A is a write cycle, so conditions are not satisfied; since the sequence conditions are not met, no user break interrupt occurs.

Break on CPU Data Access Cycle:

Register settings: BARA = H'00123456, BAMRA = H'00000000, BBRA = H'0064
 BARB = H'000ABCDE, BAMRB = H'000000FF, BBRB = H'006A
 BDRB = H'0000A512, BDMRB = H'00000000
 BR CR = H'1008

Conditions set (channel A/channel B independent mode):

Channel A: Address = H'00123456, address mask H'00000000
 Bus cycle = CPU, data access, read
 (operand size not included in conditions)

Channel B: Address = H'000ABCDE, address mask H'000000FF
 Data H'0000A512, data mask H'00000000
 Bus cycle = CPU, data access, write, word

For channel A, a user break interrupt occurs when it is read as longword at address H'00123454, as word at address H'00123456 or as byte at address H'00123456. For channel B, a user break interrupt occurs when H'A512 is written as word at H'000ABC00–H'000ABCFE.

Break on DMAC Data Access Cycle:

Register settings: BARA = H'00314156, BAMRA = H'00000000, BBRA = H'0094
 BARB = H'00055555, BAMRB = H'00000000, BBRB = H'00A9
 BDRB = H'00007878, BDMRB = H'00000F0F
 BR CR = H'1008

Conditions set (channel A/channel B independent mode):

Channel A: Address = H'00314156, address mask H'00000000
 Bus cycle = DMA, instruction fetch, read
 (operand size not included in conditions)

Channel B: Address = H'00055555, address mask H'00000000
 Data H'00007878, data mask H'00000F0F
 Bus cycle = peripheral, data access, write, byte

For channel A, a user break interrupt does not occur, since no instruction fetch occurs in the DMAC cycle. For channel B, a user break interrupt occurs when the DMAC writes H'7* (where * means don't care) as byte at H'00055555.

1. UBC registers can only be read or written to by the CPU.
2. When set for a sequential break, conditions match when a match of channel B conditions occurs some time after the bus cycle in which a channel A match occurs. This means that the conditions will not be satisfied when set for a bus cycle in which channel A and channel B occur simultaneously. Since the CPU uses a pipeline structure, the order of the instruction fetch cycle and memory cycle is fixed, so sequential conditions will be satisfied when the respective channel conditions are met in the order the bus cycles occur.
3. When set for sequential conditions (the SEQ bit in BRCCR is 1) and the instruction fetch cycle of the channel A CPU is set as a condition, set channel A for before instruction execution (PCBA bit in BRCCR is 0).
4. When register settings are changed, the write values usually become valid after three cycles. For on-chip memory, instruction fetches get two instructions simultaneously. If a break condition is set on the fetch of the second of these two instructions but the contents of the UBC registers are changed so as to alter the break condition immediately after the first of the two instructions is fetched, a user break interrupt will still occur before the second instruction. To ensure the timing of the change in the setting, read the register written last as a dummy. The changed settings will be valid thereafter.
5. When a user break interrupt is generated upon a match of the instruction fetch condition and the conditions match again in the UBC while the exception handling service routine is executing, the break will cause exception handling when the I3–I0 bits in SR are set to 14 or lower. When masking addresses, when setting instruction fetch and after-execution as break conditions, and when executing in steps, the UBC's exception service routine should not cause a match of addresses with the UBC.
6. When the emulator is used, the UBC is used on the emulator system side to implement the emulator's break function. This means none of the UBC functions can be used when the emulator is being used.

6.3.8 SH7000 Series Compatible Mode

1. In SH7000 Series compatible mode:

In SH7000 Series compatible mode, functions are as follows:

- The registers shown in the table 6.2 are valid; all others are not.
- External bus breaks are not possible in SH7000 Series compatible mode. The instruction fetch cycle occurs prior to instruction execution. The flags are not set when break conditions match.

2. Differences between SH7000 Series compatible mode and SH7604 mode:

When set for the CPU instruction fetch cycle in the SH7000 Series compatible mode, the break occurs before the instruction that matches the conditions. The break conditions differ as shown below from setting for before-execution in SH7604 mode. For data access cycles, the address is always compared to 32 bits in the SH7000 Series compatible mode, but in SH7604 mode is compared as shown in table 6.3. This produces the differences in break conditions shown in table 6.4.

Table 6.4 Differences in Break Conditions

Match Determination	SH7000 Series Compatible Mode	SH7604 Mode
Conditions match when set for instruction fetch cycle/before-execution	Breaks if instruction is overrun-fetched and not executed (as during branching)	Does not break if instruction is overrun fetched and not executed (as during branching)
Conditions match in longword access when set for addresses other than longword boundaries (4n address)	Does not break	Breaks
Conditions match in word access when set for addresses other than word boundaries (2n addresses)	Does not break	Breaks

DataSheet4U.com

et4U.com

DataShee

DataSheet4U.com

www.DataSheet4U.com

Section 7 Bus State Controller (BSC)

7.1 Overview

The bus state controller (BSC) manages the address spaces and outputs control signals so that optimum memory accesses can be made in the four spaces. This enables memories like DRAM, synchronous DRAM and pseudo-SRAM, and peripheral chips, to be linked directly.

7.1.1 Features

The BSC has the following features:

- Address space is divided into four spaces
 - A maximum linear 32 Mbytes for each of the address spaces CS0–CS3
 - The type of memory connected can be specified for each space (DRAM, synchronous DRAM, pseudo-SRAM, burst ROM, etc.).
 - Bus width can be selected for each space (8, 16, or 32 bits).
 - Wait state insertion can be controlled for each space.
 - Outputs control signals for each space.
- Cache
 - Cache areas and cache-through areas can be selected by access address.
 - When a cache access misses, 16 bytes are read consecutively in 4-byte units (because of cache fill); writes use the write-through system.
 - Cache-through accesses are accessed according to access size.
- Refresh
 - Supports CAS-before-RAS refresh (auto-refresh) and self-refresh.
 - Refresh interval can be set using the refresh counter and clock selection.
- Direct interface to DRAM
 - Multiplexes row/column address output.
 - Burst transfer during reads, high-speed page mode for consecutive accesses.
 - Generates a T_p cycle to ensure RAS precharge time.
- Direct interface to synchronous DRAM
 - Multiplexes row/column address output.
 - Burst read, single write
 - Bank active mode

- Master and slave modes (bus arbitration)
 - Total master and partial-share master modes. In total master mode, all resources are shared with other CPUs. Bus permission is shared when an external bus release request is received. In partial-share master mode, only the CS2 space is shared with other CPUs; all other spaces can be accessed at any time.
 - In slave mode, the external bus is accessed when a bus use request is output and bus use permission is received.
- Refresh counter can be used as an interval timer
 - Interrupt request generated upon compare match (CMI interrupt request signal).

7.1.2 Block Diagram

Figure 7.1 shows the BSC block diagram.

DataSheet4U.com

et4U.com

DataShee

DataSheet4U.com

www.DataSheet4U.com

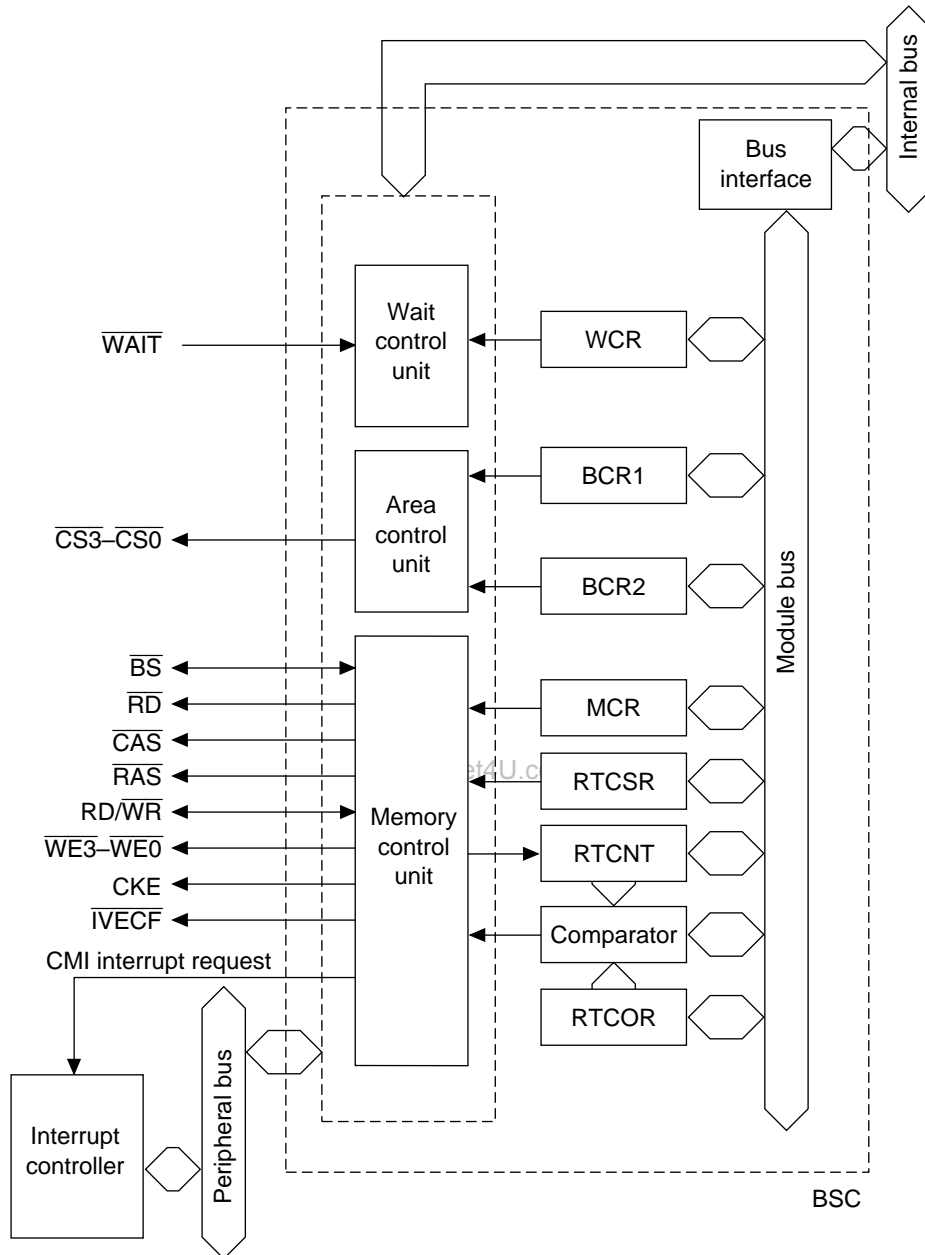

WCR: Wait control register
 BCR: Bus control register
 MCR: Individual memory control register

RTCNT: Refresh timer counter
 RTCOR: Refresh time constant register
 RTCSCR: Refresh timer control/status register

Figure 7.1 BSC Block Diagram

Table 7.1 lists the bus state controller pin configuration.

Table 7.1 Pin Configuration

Signal	I/O	With Bus Released	Description
A26–A0	I/O	I	Address bus. 27 bits are available to specify a total 128 Mbytes of memory space. The most significant 2 bits are used to specify the CS space, so the size of the spaces is 32 Mbytes. When the bus is released, these become inputs for the external bus cycle address monitor.
D31–D0	I/O	Hi-Z	32-bit data bus. When reading or writing a 16-bit width area, use D15–D0; when reading or writing a 8-bit width area, use D7–D0. With 8-bit accesses that read or write a 32-bit width area, input and output the data via the byte position determined by the lower address bits of the 32-bit bus.
\overline{BS}	I/O	I	Indicates start of bus cycle or monitor. With the basic interface (device interfaces except for DRAM, synchronous DRAM, pseudo-SRAM), signal is asserted for a single clock cycle simultaneous with address output. The start of the bus cycle can be determined by this signal. This signal is asserted for 1 cycle synchronous with column address output in DRAM, synchronous DRAM and pseudo-SRAM accesses. When the bus is released, \overline{BS} becomes an input for address monitoring of external bus cycles.
$\overline{CS0}$ – $\overline{CS3}$	O	Hi-Z	Chip select. Signals that select area; specified by A26 and A25.
$\overline{RD}/\overline{WR}$, \overline{WE}	I/O	I	Read/write signal. Signal that indicates access cycle direction (read/write). Connected to \overline{WE} pin when DRAM/synchronous DRAM is connected. When the bus is released, becomes an input for address monitoring of external bus cycles.
\overline{RAS} , \overline{CE}	O	Hi-Z	\overline{RAS} pin for DRAM/synchronous DRAM. \overline{CE} pin for pseudo-SRAM.
\overline{CAS} , \overline{OE}	O	Hi-Z	Open when using DRAM. \overline{CAS} pin for synchronous DRAM. \overline{OE} pin for pseudo-SRAM.
\overline{CASHH} , \overline{DQMUU} , $\overline{WE3}$	O	Hi-Z	When DRAM is used, connected to \overline{CAS} pin for the most significant byte (D31–D24). When synchronous DRAM is used, connected to DQM pin for the most significant byte. When pseudo-SRAM is used, connected to \overline{WE} pin for the most significant byte. For basic interface, indicates writing to the most significant byte.
\overline{CASHL} , \overline{DQMUL} , $\overline{WE2}$	O	Hi-Z	When DRAM is used, connected to \overline{CAS} pin for the second byte (D23–D16). When synchronous DRAM is used, connected to DQM pin for the second byte. When pseudo-SRAM is used, connected to \overline{WE} pin for the second byte. For basic interface, indicates writing to the second byte.

Table 7.1 Pin Configuration (cont)

Signal	I/O	With Bus Released	Description
$\overline{\text{CASLH}}$, $\overline{\text{DQMLU}}$, $\overline{\text{WE1}}$	O	Hi-Z	When DRAM is used, connected to $\overline{\text{CAS}}$ pin for the third byte (D15–D8). When synchronous DRAM is used, connected to $\overline{\text{DQM}}$ pin for the third byte. When pseudo-SRAM is used, connected to $\overline{\text{WE}}$ pin for the third byte. For basic interface, indicates writing to the third byte.
$\overline{\text{CASLL}}$, $\overline{\text{DQMLL}}$, $\overline{\text{WE0}}$	O	Hi-Z	When DRAM is used, connected to $\overline{\text{CAS}}$ pin for the least significant byte (D7–D0). When synchronous DRAM is used, connected to $\overline{\text{DQM}}$ pin for the least significant byte. When pseudo-SRAM is used, connected to $\overline{\text{WE}}$ pin for the least significant byte. For basic interface, indicates writing to the least significant byte.
$\overline{\text{RD}}$	O	Hi-Z	Read pulse signal (read data output enable signal). Normally, connected to the device's /OE pin; when there is an external data buffer, the read cycle data can only be output when this signal is low.
$\overline{\text{WAIT}}$	I	Ignore	Hardware wait input.
$\overline{\text{BACK}}$, $\overline{\text{BRLS}}$	I	I	Bus use enable input in partial-share master or slave mode: $\overline{\text{BACK}}$. Bus release request input in total master: $\overline{\text{BRLS}}$.
$\overline{\text{BREQ}}$, $\overline{\text{BGR}}$	O	O	Bus request output in partial-share master or slave mode: $\overline{\text{BREQ}}$. Bus grant output in total master: $\overline{\text{BGR}}$.
$\overline{\text{CKE}}$	O	O	Synchronous DRAM clock enable control. Signal for supporting synchronous DRAM self-refresh.
$\overline{\text{IVECF}}$	O	Hi-Z	Interrupt vector fetch.
$\overline{\text{DREQ0}}$	I	I	DMA request 0.
$\overline{\text{DACK0}}$	O	O	DMA acknowledge 0.
$\overline{\text{DREQ1}}$	I	I	DMA request 1.
$\overline{\text{DACK1}}$	O	O	DMA acknowledge 1.

Note: Hi-Z: High impedance

7.1.4 Register Configuration

The BSC has seven registers. These registers are used to control wait states, bus width, interfaces with memories like DRAM, synchronous DRAM, pseudo-SRAM, and burst ROM, and DRAM, synchronous DRAM, and pseudo-SRAM refreshing. The register configurations are shown in table 7.2.

The size of the registers themselves is 16 bits. If read as 32 bits, the upper 16 bits are 0. *In order to prevent writing mistakes, 32-bit writes are accepted only when the value of the upper 16 bits of the write data is H'A55A; no other writes are performed.* Initialize the reserved bits.

Initialization Procedure: Do not access a space other than CS0 until the settings for the interface to memory are completed.

Table 7.2 Register Configuration

Name	Abbr.	R/W	Initial Value	Address* ¹	Access Size
Bus control register 1	BCR1	R/W	H'03F0	H'FFFFFFE0	16* ² , 32
Bus control register 2	BCR2	R/W	H'00FC	H'FFFFFFE4	16* ² , 32
Wait control register	WCR	R/W	H'AAFF	H'FFFFFFE8	16* ² , 32
Individual memory control register	MCR	R/W	H'0000	H'FFFFFFEC	16* ² , 32
Refresh timer control/status register	RTCSR	R/W	H'0000	H'FFFFFFF0	16* ² , 32
Refresh timer counter	RTCNT	R/W	H'0000	H'FFFFFFF4	16* ² , 32
Refresh time constant register	RTCOR	R/W	H'0000	H'FFFFFFF8	16* ² , 32

Notes: 1. This address is for 32-bit accesses; for 16-bit accesses add 2.
2. 16-bit access is for read only.

7.1.5 Address Map

The SH7604 address map, which has a memory space of 256 Mbytes, is divided into four spaces. The types and data width of devices that can be connected are specified for each space. The overall space address map is shown in table 7.3. Since the spaces of the cache area and the cache-through area are the same, the maximum memory space that can be connected is 128 Mbytes. This means that when address H'20000000 is accessed in a program, the data accessed is actually in H'00000000.

There are several spaces for cache control. These include the associative purge space for cache purges, address array read/write space for reading and writing addresses (address tags), and data array read/write space for forced reads and writes of data arrays.

Table 7.3 Address Map

Address	Space	Memory	Size
H'00000000 to H'01FFFFFF	CS0 space, cache area	Ordinary space or burst ROM	32 Mbytes
H'02000000 to H'03FFFFFF	CS1 space, cache area	Ordinary space	32 Mbytes
H'04000000 to H'05FFFFFF	CS2 space, cache area	Ordinary space or synchronous DRAM	32 Mbytes
H'06000000 to H'07FFFFFF	CS3 space, cache area	Ordinary space, synchronous DRAM, DRAM or pseudo-DRAM	32 Mbytes
H'08000000 to H'1FFFFFFF	Reserved		
H'20000000 to H'21FFFFFF	CS0 space, cache-through area	Ordinary space or burst ROM	(32 Mbytes)
H'22000000 to H'23FFFFFF	CS1 space, cache-through area	Ordinary space	(32 Mbytes)
H'24000000 to H'25FFFFFF	CS2 space, cache-through area	Ordinary space or synchronous DRAM	(32 Mbytes)
H'26000000 to H'27FFFFFF	CS3 space, cache-through area	Ordinary space, synchronous DRAM, DRAM or pseudo-DRAM	(32 Mbytes)
H'28000000 to H'3FFFFFFF	Reserved		
H'40000000 to H'47FFFFFF	Associative purge space		128 Mbytes
H'48000000 to H'5FFFFFFF	Reserved		
H'60000000 to H'7FFFFFFF	Address array, read/write space		512 Mbytes
H'80000000 to H'BFFFFFFF	Reserved		
H'C0000000 to H'C0000FFF	Data array, read/write space		4 kbytes
H'C0001000 to H'DFFFFFFF	Reserved		
H'E0001000 to H'FFFF7FFF	Reserved		
H'FFFF8000 to H'FFFFBFFF	For setting synchronous DRAM mode		16 kbytes
H'FFFC000 to H'FFFFDFF	Reserved		15.5 kbytes
H'FFFFE00 to H'FFFFFFF	On-chip peripheral modules		512 bytes

Note: Do not access reserved spaces, as this will cause operating errors.

7.2 Description of Registers

7.2.1 Bus Control Register 1 (BCR1)

Bit:	15	14	13	12	11	10	9	8
Bit name:	MASTER	—	—	ENDIAN	BSTROM	PSHR	AHLW1	AHLW0
Initial value:	—	0	0	0	0	0	1	1
R/W:	R	R	R	R/W	R/W	R/W	R/W	R/W

Bit:	7	6	5	4	3	2	1	0
Bit name:	A1LW1	A1LW0	A0LW1	A0LW0	—	DRAM2	DRAM1	DRAM0
Initial value:	1	1	1	1	0	0	0	0
R/W:	R/W	R/W	R/W	R/W	R	R/W	R/W	R/W

Initialize ENDIAN, BSTROM, PSHR and DRAM2–DRAM0 bits after a power-on reset and do not write to them thereafter. To change other bits by writing to them, write the same value as they are initialized to. Do not access any space other than CS0 until the register initialization ends.

- Bit 15—Bus Arbitration (MASTER): The MASTER bit is used to check the settings of the bus arbitration function set by the mode settings with the external input pin. It is a read-only bit.

DataSheet4U.com

Bit 15 (MASTER)	Description
0	Master mode
1	Slave mode

et4U.com

DataShe

- Bits 14, 13, and 3—Reserved bits: These bits always read 0. The write value should always be 0.
- Bit 12—Endian Specification for Area 2 (ENDIAN): In big-endian format, the MSB of byte data is the lowest byte address and byte data goes in order toward the LSB. For little-endian format, the LSB of byte data is the lowest byte address and byte data goes in order toward the MSB. When this bit is 1, the data is rearranged into little-endian format before transfer when the CS2 space is read or written to. It is used when handling data with little-endian processors or running programs written with little-endian format in mind.

Bit 12: ENDIAN	Description
0	Big-endian, as in other areas (Initial value)
1	Little-endian

DataSheet4U.com

www.DataSheet4U.com

- Bit 11—Area 0 Burst ROM Enable (BSTROM)

Bit 11: BSTROM	Description	
0	Area 0 is accessed normally	(Initial value)
1	Area 0 is accessed as burst ROM	

- Bit 10—Partial Space Share Specification (PSHR): When bus arbitration is in master mode and the PSHR bit is 1, only area 2 is handled as a shared space. When areas other than area 2 are accessed, bus ownership is not requested. When this bit is 1, address monitor specification is disabled. This mode is called partial-share master mode. The initial value is 0.
- Bits 9 and 8—Long Wait Specification for Areas 2 and 3 (AHLW1, AHLW0): When the basic memory interface setting is made for area 2 and area 3, the wait specification of this field is effective when the bits that specify the respective area waits in the wait control register (W21/W20 or W31/W30) specify long waits (i.e., 11).

Bit 9: AHLW1	Bit 8: AHLW0	Description	
0	0	3 waits	
	1	4 waits	
1	0	5 waits	
	1	6 waits	(Initial value)

DataSheet4U.com

- Bits 7 and 6—Long Wait Specification for Area 1 (A1LW1, A1LW0): When the basic memory interface setting is made for area 1, the wait specification of this field is effective when the bits that specify the wait in the wait control register specify long wait (i.e., 11).

Bit 7: A1LW1	Bit 6: A1LW0	Description	
0	0	3 waits	
	1	4 waits	
1	0	5 waits	
	1	6 waits	(Initial value)

- Bits 5 and 4—Long Wait Specification for Area 0 (A0LW1, A0LW0): When the basic memory interface setting is made for area 0, the wait specification of this field is effective when the bits that specify the wait in the wait control register specify long wait (i.e., 11).

Bit 5: A0LW1	Bit 4: A0LW0	Description
0	0	3 waits (Initial value)
	1	4 waits
1	0	5 waits
	1	6 waits

- Bits 2 to 0—Enable for DRAM and Other Memory (DRAM2–DRAM0)

DRAM2	DRAM1	DRAM0	Description
0	0	0	Areas 2 and 3 are ordinary spaces (Initial value)
		1	Area 2 is ordinary space; area 3 is synchronous DRAM space
	1	0	Area 2 is ordinary space; area 3 is DRAM space
		1	Area 2 is ordinary space; area 3 is pseudo-SRAM space
1	0	0	Area 2 is synchronous DRAM space, area 3 is ordinary space
		1	Areas 2 and 3 are synchronous DRAM spaces
	1	0	Reserved (do not set)
		1	Reserved (do not set)

7.2.2 Bus Control Register 2 (BCR2)

Bit:	15	14	13	12	11	10	9	8
Bit name:	—	—	—	—	—	—	—	—
Initial value:	0	0	0	0	0	0	0	0
R/W:	R	R	R	R	R	R	R	R
Bit:	7	6	5	4	3	2	1	0
Bit name:	A3SZ1	A3SZ0	A2SZ1	A2SZ0	A1SZ1	A1SZ0	—	—
Initial value:	1	1	1	1	1	1	0	0
R/W:	R/W	R/W	R/W	R/W	R/W	R/W	R	R

Initialize BCR2 after a power-on reset and do not write to it thereafter. When writing to it, write the same values as those the bits are initialized to. Do not access any space other than CS0 until the register initialization ends.

- Bits 15 to 8—Reserved: These bits always read 0. The write value should always be 0.
- Bits 7 and 6—Bus Size Specification for Area 3 (A3SZ1–A3SZ0). Effective only when ordinary space is set.

Bit 7: A3SZ1	Bit 6: A3SZ0	Description
0	0	Reserved (do not set)
	1	Byte (8-bit) size
1	0	Word (16-bit) size
	1	Longword (32-bit) size (Initial value)

- Bits 5 and 4—Bus Size Specification for Area 2 (A2SZ1–A2SZ0): Effective only when ordinary space is set.

Bit 5: A2SZ1	Bit 4: A2SZ0	Description
0	0	Reserved (do not set)
	1	Byte (8-bit) size
1	0	Word (16-bit) size
	1	Longword (32-bit) size (Initial value)

- Bits 3 and 2—Bus Size Specification for Area 1 (A1SZ1–A1SZ0)

Bit 3: A1SZ1	Bit 2: A1SZ0	Description
0	0	Reserved (do not set)
	1	Byte (8-bit) size
1	0	Word (16-bit) size
	1	Longword (32-bit) size (Initial value)

- Bits 1 and 0—Reserved: These bits always read 0. The write value should always be 0.

Note: The bus size of area 0 is specified by the mode input pins.

7.2.3 Wait Control Register (WCR)

Bit:	15	14	13	12	11	10	9	8
Bit name:	IW31	IW30	IW21	IW20	IW11	IW10	IW01	IW00
Initial value:	1	0	1	0	1	0	1	0
R/W:	R/W	R/W	R/W	R/W	R/W	R/W	R/W	R/W
Bit:	7	6	5	4	3	2	1	0
Bit name:	W31	W30	W21	W20	W11	W10	W01	W00
Initial value:	1	1	1	1	1	1	1	1
R/W:	R/W	R/W	R/W	R/W	R/W	R/W	R/W	R/W

Do not access a space other than CS0 until the settings for register initialization are completed.

- Bits 15 to 8—Idles between Cycles for Areas 3 to 0 (IW31–IW00): These bits specify idle cycles inserted between consecutive accesses to different areas. Idles are used to prevent data conflict between ROM or the like, which is slow to turn the read buffer off, and fast memories and I/O interfaces. Even when access is to the same area, idle cycles must be inserted when a read access is followed immediately by a write access. The idle cycles to be inserted comply with the specification for the previously accessed area.

IW31, IW21, IW11, IW01	IW30, IW20, IW10, IW00	Description
0	0	No idle cycle
	1	One idle cycle inserted
1	0	Two idle cycles inserted (Initial value)
	1	Reserved (do not set)

- Bits 7 to 0—Wait Control for Areas 3 to 0 (W31–W00)

During the basic cycle:

W31, W21, W11, W01	W30, W20, W10, W00	Description
0	0	External wait input disabled without wait
0	1	External wait input enabled with one wait
1	0	External wait input enabled with two waits
1	1	Complies with the long wait specification of bus control register 1 (BCR1). External wait input is enabled (Initial value)

When area 3 is DRAM, the number of CAS assert cycles is specified by wait control bits W31 and W30:

Bit 7: W31	Bit 6: W30	Description
0	0	1 cycle
	1	2 cycles
1	0	3 cycles
	1	Reserved (do not set)

When the setting is for 2 or more cycles, external wait input is enabled.

When area 2 or 3 is synchronous DRAM, CAS latency is specified by wait control bits W31 and W30, and W21 and W20, respectively:

W31, W21	W30, W20	Description
0	0	1 cycle
	1	2 cycles
1	0	3 cycles
	1	4 cycles

With synchronous DRAM, external wait input is ignored regardless of any setting.

When area 3 is pseudo-SRAM, the number of cycles from \overline{BS} signal assertion to the end of the cycle is specified by wait control bits W31 and W30:

Bit 7: W31	Bit 6: W30	Description
0	0	2 cycles
	1	3 cycles
1	0	4 cycles
	1	Reserved (do not set)

When the setting is for 3 or more cycles, external wait input is enabled.

7.2.4 Individual Memory Control Register (MCR)

Bit:	15	14	13	12	11	10	9	8
Bit name:	TRP	RCD	TRWL	TRAS1	TRAS0	BE	RASD	—
Initial value:	0	0	0	0	0	0	0	0
R/W:	R/W	R/W	R/W	R/W	R/W	R/W	R/W	R
Bit:	7	6	5	4	3	2	1	0
Bit name:	AMX2	SZ	AMX1	AMX0	RFSH	RMD	—	—
Initial value:	0	0	0	0	0	0	0	0
R/W:	R/W	R/W	R/W	R/W	R/W	R/W	R	R

The TRP, RCD, TRWL, TRAS1–TRAS0, BE, RASD, AMX2–AMX0 and SZ bits are initialized after a power-on reset. Do not write to them thereafter. When writing to them, write the same values as they are initialized to. Do not access any space other than CS2 and CS3 until the register initialization ends.

- Bit 15—RAS Precharge Time (TRP): When DRAM is connected, specifies the minimum number of cycles after $\overline{\text{RAS}}$ is negated before the next assert. When pseudo-SRAM is connected, specifies the minimum number of cycles after $\overline{\text{CE}}$ is negated before the next assert. When synchronous DRAM is connected, specifies the minimum number of cycles after precharge until a bank active command is output. See section 7.5, Synchronous DRAM Interface, for details.

Bit 15: TRP	Description
0	1 cycle (Initial value)
1	2 cycles

- Bit 14—RAS-CAS Delay (RCD): When DRAM is connected, specifies the number of cycles after $\overline{\text{RAS}}$ is asserted before $\overline{\text{CAS}}$ is asserted. When pseudo-SRAM is connected, specifies the number of cycles after $\overline{\text{CE}}$ is asserted before $\overline{\text{BS}}$ is asserted. When synchronous DRAM is connected, specifies the number of cycles after a bank active (ACTV) command is issued until a read or write command (READ, READA, WRIT, WRITA) is issued.

Bit 14: RCD	Description
0	1 cycle (Initial value)
1	2 cycles

- **Bit 13—Write-Precharge Delay (TRWL):** When the synchronous DRAM is not in the bank active mode, this bit specifies the number of cycles between the write cycle and the start-up of the auto-precharge. The timing from this point to the point at which the next command can be issued is calculated within the bus state controller. In bank active mode, this bit specifies the period for which the precharge command is disabled after the write command (WRIT) is issued. This bit is ignored when memory other than synchronous DRAM is connected.

Bit 13: TRWL	Description
0	1 cycle (Initial value)
1	2 cycles

- **Bits 12 and 11—CAS-Before-RAS Refresh RAS Assert Time (TRAS1–TRAS0):** The RAS assertion width for DRAM is TRAS; the \overline{OE} width for pseudo-SRAM is TRAS + 1 cycle. After an auto-refresh command is issued, the synchronous DRAM does not issue a bank active command for TRAS + 2 cycles, regardless of the TRP bit setting. For synchronous DRAMs, there is no RAS assertion period, but there is a limit for the time from the issue of a refresh command until the next access. This value is set to observe this limit. Commands are not issued for TRAS + 1 cycle when self-refresh is cleared.

Bit 12: TRAS1	Bit 11: TRAS0	Description
0	0	2 cycles (Initial value)
	1	3 cycles
1	0	4 cycles
	1	Reserved (do not set)

- **Bit 10—Burst Enable (BE)**

Bit 10: BE	Description
0	Burst disabled (Initial value)
1	High-speed page mode during DRAM interfacing is enabled. Data is continuously transferred in static column mode during pseudo-SRAM interfacing. During synchronous DRAM access, burst operation is always enabled regardless of this bit.

- Bit 9—RAS Down Mode (RASD)

Bit 9: RASD	Description
0	For DRAM, RAS is negated after access ends (normal operation). For synchronous DRAM, a read or write is performed using auto-precharge mode. The next access always starts with a bank active command.
1	For DRAM, after access ends RAS down mode is entered in which RAS is left asserted. When using this mode with an external device connected which performs writes other than to DRAM, see section 7.6.5, Burst Access. For synchronous DRAM, access ends in the bank active state. This is only valid for area 3. When area 2 is synchronous DRAM, the mode is always auto-precharge.

- Bits 7, 5, and 4—Address Multiplex (AMX2–AMX0)

For DRAM interface:

Bit 7: AMX2	Bit 5: AMX1	Bit 4: AMX0	Description
0	0	0	8-bit column address DRAM
		1	9-bit column address DRAM
	1	0	10-bit column address DRAM
		1	11-bit column address DRAM
1	0	0	Reserved (do not set)
		1	Reserved (do not set)
	1	0	Reserved (do not set)
		1	Reserved (do not set)

For synchronous DRAM interface:

Bit 7: AMX2	Bit 5: AMX1	Bit 4: AMX0	Description
0	0	0	16-Mbit DRAM (1M × 16 bits)
		1	16-Mbit DRAM (2M × 8 bits)*
	1	0	16-Mbit DRAM (4M × 4 bits)*
		1	4-Mbit DRAM (256k × 16 bits)
1	0	0	Reserved (do not set)
		1	Reserved (do not set)
	1	0	Reserved (do not set)
		1	2-Mbit DRAM (128k × 16 bits)

Note: Reserved. Do not set when SZ bit in MCR is 0 (16-bit bus width).

- Bit 6—Memory Data Size (SZ): For synchronous DRAM, DRAM, and pseudo-SRAM space, the data bus width of BCR2 is ignored in favor of the specification of this bit.

Bit 6: SZ	Description
0	Word (Initial value)
1	Longword

DataSheet4U.com

- Bit 3—Refresh Control (RFSH): This bit determines whether or not the refresh operation of DRAM/synchronous DRAM/pseudo-SRAM is performed. This bit is not valid in the slave mode and is always handled as 0.

Bit 3: RFSH	Description
0	No refresh (Initial value)
1	Refresh

- Bit 2—Refresh Mode (RMODE): When the RFSH bit is 1, this bit selects normal refresh or self-refresh. When the RFSH bit is 0, do not set this bit to 1. When the RFSH bit is 1, self-refresh mode is entered immediately after the RMD bit is set to 1. When the RFSH bit is 1 and this bit is 0, a CAS-before-RAS refresh or auto-refresh is performed at the interval set in the 8-bit interval timer. When a refresh request occurs during an external area access, the refresh is performed after the access cycle is completed. When set for self-refresh, self-refresh mode is entered immediately unless the SH7604 is in the middle of an synchronous DRAM or pseudo-SRAM area access. If it is, self-refresh mode is entered when the access ends. Refresh requests from the interval timer are ignored during self-refresh. Self-refresh is not supported for DRAM, so always set RMD to 0 when using DRAM.

Bit 2: RMODE	Description
0	Normal refresh (Initial value)
1	Self-refresh

- Bits 8, 1, and 0—Reserved: These bits always read 0.

7.2.5 Refresh Timer Control/Status Register (RTCSR)

Bit:	15	14	13	12	11	10	9	8
Bit name:	—	—	—	—	—	—	—	—
Initial value:	0	0	0	0	0	0	0	0
R/W:	R	R	R	R	R	R	R	R
Bit:	7	6	5	4	3	2	1	0
Bit name:	CMF	CMIE	CKS2	CKS1	CKS0	—	—	—
Initial value:	0	0	0	0	0	0	0	0
R/W:	R/W	R/W	R/W	R/W	R/W	R	R	R

- Bits 15 to 8—Reserved: These bits always read 0.
- Bit 7—Compare Match Flag (CMF): This status flag, which indicates that the values of RTCNT and RTCOR match, is set/cleared under the following conditions:

Bit 7: CMF	Description
0	RTCNT and RTCOR match Clear condition: After RTCSR is read when CMF is 1, 0 is written in CMF
1	RTCNT and RTCOR do not match Set condition: RTCNT = RTCOR

- Bit 6—Compare Match Interrupt Enable (CMIE): Enables or disables an interrupt request caused by the CMF bit of RTSCR when CMF is set to 1.

Bit 6: CMIE	Description
0	Interrupt request caused by CMF is disabled (Initial value)
1	Interrupt request caused by CMF is enabled

- Bits 5 to 3—Clock Select Bits (CKS2–CKS0)

Bit 5: CKS2	Bit 4: CKS1	Bit 3: CKS0	Description
0	0	0	Count-up disabled (Initial value)
		1	CLK/4
	1	0	CLK/16
		1	CLK/64
1	0	0	CLK/256
		1	CLK/1024
	1	0	CLK/2048
		1	CLK/4096

- Bits 2 to 0—Reserved: These bits always read 0. The write value should always be 0.

7.2.6 Refresh Timer Counter (RTCNT)

Bit:	15	14	13	12	11	10	9	8
Bit name:	—	—	—	—	—	—	—	—
Initial value:	0	0	0	0	0	0	0	0
R/W:	R	R	R	R	R	R	R	R
Bit:	7	6	5	4	3	2	1	0
Bit name:								
Initial value:	0	0	0	0	0	0	0	0
R/W:	R/W	R/W	R/W	R/W	R/W	R/W	R/W	R/W

The 8-bit counter RTCNT counts up with input clocks. The clock select bit of RTCSR selects an input clock. RTCNT values can always be read/written by the CPU. When RTCNT matches RTCOR, RTCNT is cleared. Returns to 0 after it counts up to 255.

- Bits 15 to 8—Reserved: These bits always read 0. The write value should always be 0.

7.2.7 Refresh Time Constant Register (RTCOR)

Bit:	15	14	13	12	11	10	9	8
Bit name:	—	—	—	—	—	—	—	—
Initial value:	0	0	0	0	0	0	0	0
R/W:	R	R	R	R	R	R	R	R
Bit:	7	6	5	4	3	2	1	0
Bit name:								
Initial value:	0	0	0	0	0	0	0	0
R/W:	R/W	R/W	R/W	R/W	R/W	R/W	R/W	R/W

RTCOR is an 8-bit read/write register. The values of RTCOR and RTCNT are constantly compared. When the values correspond, the compare match flag in RTCSR is set and RTCNT is cleared to 0. When the refresh bit (RFSH) in the individual memory control register is set to 1, a refresh request signal occurs. The refresh request signal is held until refresh operation is performed. If the refresh request is not processed before the next match, the previous request becomes ineffective.

When the CMIE bit in RTSCR is set to 1, an interrupt request is sent to the controller by this match signal. The interrupt request is output continuously until the CMF bit in RTSCR is cleared. When the CMF bit clears, it only affects the interrupt; the refresh request is not cleared by this operation. When a refresh is performed and refresh requests are counted using interrupts, a refresh can be set simultaneously with the interval timer interrupt.

Bits 15 to 8—Reserved: These bits always read 0. The write value should always be 0.

7.3 Access Size and Data Alignment

7.3.1 Connection to Ordinary Devices

Byte, word, and longword are supported as access units. Data is aligned based on the data width of the device. Therefore, reading longword data from a byte-width device requires four read operations. The bus state controller automatically converts data alignment and data length between interfaces. The data width for external devices can be connected to either 8 bits, 16 bits or 32 bits by setting BCR2 (for the CS1–CS3 spaces) or using the mode pins (for the CS0 space). Since the data width of devices connected to the respective spaces is specified statically, however, the data width cannot be changed for each access cycle.

Instruction fetches are always performed in 32-bit units. When branching to an odd word boundary ($4n + 2$ address), instruction fetches are performed in longword units from a $4n$ address. Figures 7.2 to 7.4 show the relationship between device data widths and access units.

A26-A0	D31	D23	D15	D7	D0	
000000	7	0				32-bit device data input/output pin Byte read/write of address 0
000001		7	0			Byte read/write of address 1
000002			7	0		Byte read/write of address 2
000003				7	0	Byte read/write of address 3
000000	15	8, 7	0			Word read/write of address 0
000002			15	8, 7	0	Word read/write of address 2
000000	31	24, 23	16, 15	8, 7	0	Longword read/write of address 0

Figure 7.2 32-Bit External Devices and Their Access Units (Ordinary)

A26-A0	D15	D7	D0	
000000	7	0		16-bit device data input/output pin Byte read/write of address 0
000001		7	0	Byte read/write of address 1
000002	7	0		Byte read/write of address 2
000003		7	0	Byte read/write of address 3
000000	15		0	Word read/write of address 0
000002	15		0	Word read/write of address 2
000000	31		16	} Longword read/write of address 0
000002	15		0	

Figure 7.3 16-Bit External Devices and Their Access Units (Ordinary)

A26-A0	D7	D0	
000000	7	0	8-bit device data input/output pin Byte read/write of address 0
000001	7	0	Byte read/write of address 1
000002	7	0	Byte read/write of address 2
000003	7	0	Byte read/write of address 3
000000	15	8	} Word read/write of address 0
000001	7	0	
000002	15	8	} Word read/write of address 2
000003	7	0	
000000	31	24	} Longword read/write of address 0
000001	23	26	
000002	15	8	
000003	7	0	

Figure 7.4 8-Bit External Devices and Their Access Units (Ordinary)

The SH7604 provides a conversion function in CS2 space for connection to and to maintain program compatibility with devices that use little-endian format (in which the LSB is the 0 position in the byte data lineup). When the endian specification bit of BCR1 is set to 1, CS2 space is little-endian. The relationship between device data width and access unit for little-endian format is shown in figures 7.5 and 7.6. When sharing memory or the like with a little-endian bus master, the SH7604 connects D31–D24 to the least significant byte of the other bus master and D7–D0 to the most significant byte, when the bus width is 32 bits. When the width is 16 bits, the SH7604 connects D15–D8 to the least significant byte of the other bus master and D7–D0 to the most significant byte.

When support software like the compiler or linker does not support switching, the instruction code and constants in the program do not become little-endian. For this reason, be careful not to place program code or constants in the CS2 space. When instructions or data in other CS spaces are used by transferring them to CS2 space with the SH7604, there is no problem because the SH7604 converts the endian format. Programs that are designed for use with little-endian format assume that the LSB is stored in the lowest address. Even when a program written in a high-level language like C is recompiled as is, it may not execute properly. The sign bit of signed 16-bit data at address 0 is stored at address 1 in little-endian format and at address 0 in big-endian format. It is possible to correctly execute a program written for little-endian format by allocating the program and constants to an area other than CS2 space and the data area to CS2 space. Note that the SH7604 does not support little-endian mode for devices with an 8-bit data bus width.

A26–A0	D31	D23	D15	D7	D0	32-bit device data input/output pin
000000	<u>7</u>	<u>0</u>				Byte read/write of address 0
000001		<u>7</u>	<u>0</u>			Byte read/write of address 1
000002			<u>7</u>	<u>0</u>		Byte read/write of address 2
000003				<u>7</u>	<u>0</u>	Byte read/write of address 3
000000	<u>7</u>	<u>0, 15</u>	<u>8</u>			Word read/write of address 0
000002			<u>7</u>	<u>0, 15</u>	<u>8</u>	Word read/write of address 2
000000	<u>7</u>	<u>0, 15</u>	<u>8, 23</u>	<u>16, 31</u>	<u>24</u>	Longword read/write of address 0

Figure 7.5 32-Bit External Devices and Their Access Units (Little-Endian Format)

A26-A0	D15	D7	D0	
000000	7	0		16-bit device data input/output pin
000001	7	0		Byte read/write of address 0
000002	7	0		Byte read/write of address 1
000003	7	0		Byte read/write of address 2
000000	7	0, 15	8	Byte read/write of address 3
000002	7	0, 15	8	Word read/write of address 0
000000	7	0, 15	8	Word read/write of address 2
000002	23	16, 31	24	Longword read/write of address 0

Figure 7.6 16-Bit External Devices and Their Access Units (Little-Endian Format)

Using the Little-Endian Function: The SH7604 normally uses big-endian alignment for data input and output, but an endian conversion function is provided for the CS2 space to enable connection to little-endian devices. The following two points should be noted when using this function:

- Little endian alignment should be used in the CS2 through-area.
- When data is shared with another little-endian device using this function, the same access size must be used by both. For example, to read data written in longword size by another little-endian device, the SH7604 must use longword read access.

7.4 Accessing Ordinary Space

7.4.1 Basic Timing

A strobe signal is output by ordinary space accesses of CS0–CS3 spaces to provide primarily for SRAM direct connections. Figure 7.7 shows the basic timing of ordinary space accesses. Ordinary accesses without waits end in 2 cycles. The \overline{BS} signal is asserted for 1 cycle to indicate the start of the bus cycle. The \overline{CSn} signal is negated by the fall of clock T2 to ensure the negate period. The negate period is thus half a cycle when accessed at the minimum pitch.

The access size is not specified during a read. The correct access start address will be output to the LSB of the address, but since no access size is specified, the read will always be 32 bits for 32-bit devices and 16 bits for 16-bit devices. For writes, only the \overline{WE} signal of the byte that will be written is asserted. For 32-bit devices, $\overline{WE3}$ specifies writing to a $4n$ address and $\overline{WE0}$ specifies writing to a $4n+3$ address. For 16-bit devices, $\overline{WE1}$ specifies writing to a $2n$ address and $\overline{WE0}$ specifies writing to a $2n+1$ address. For 8-bit devices, only $\overline{WE0}$ is used.

The \overline{RD} signal must be used to control data output of external devices so that conflicts do not occur between trace information for emulators or the like output from the SH7604 and external device read data. In other words, when data buses are provided with buffers, the \overline{RD} signal must be used for data output in the read direction. When $\overline{RD}/\overline{WR}$ signals do not perform accesses, the

chip stays in read status, so there is a danger of conflicts occurring with output when this is used to control the external data buffer.

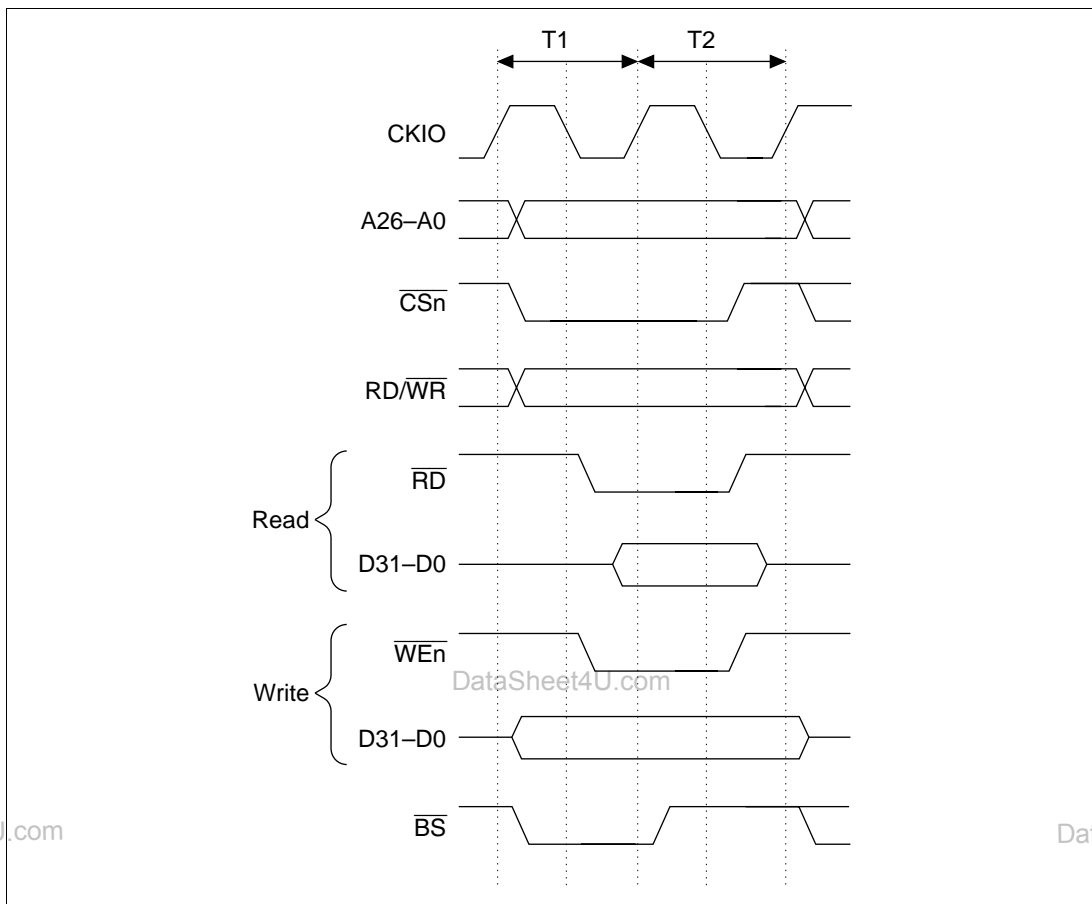

Figure 7.7 Basic Timing of Ordinary Space Access

Figure 7.8 shows an example of a 32-bit data width SRAM connection, figure 7.9 a 16-bit data width SRAM connection, and figure 7.10 an 8-bit data width SRAM connection.

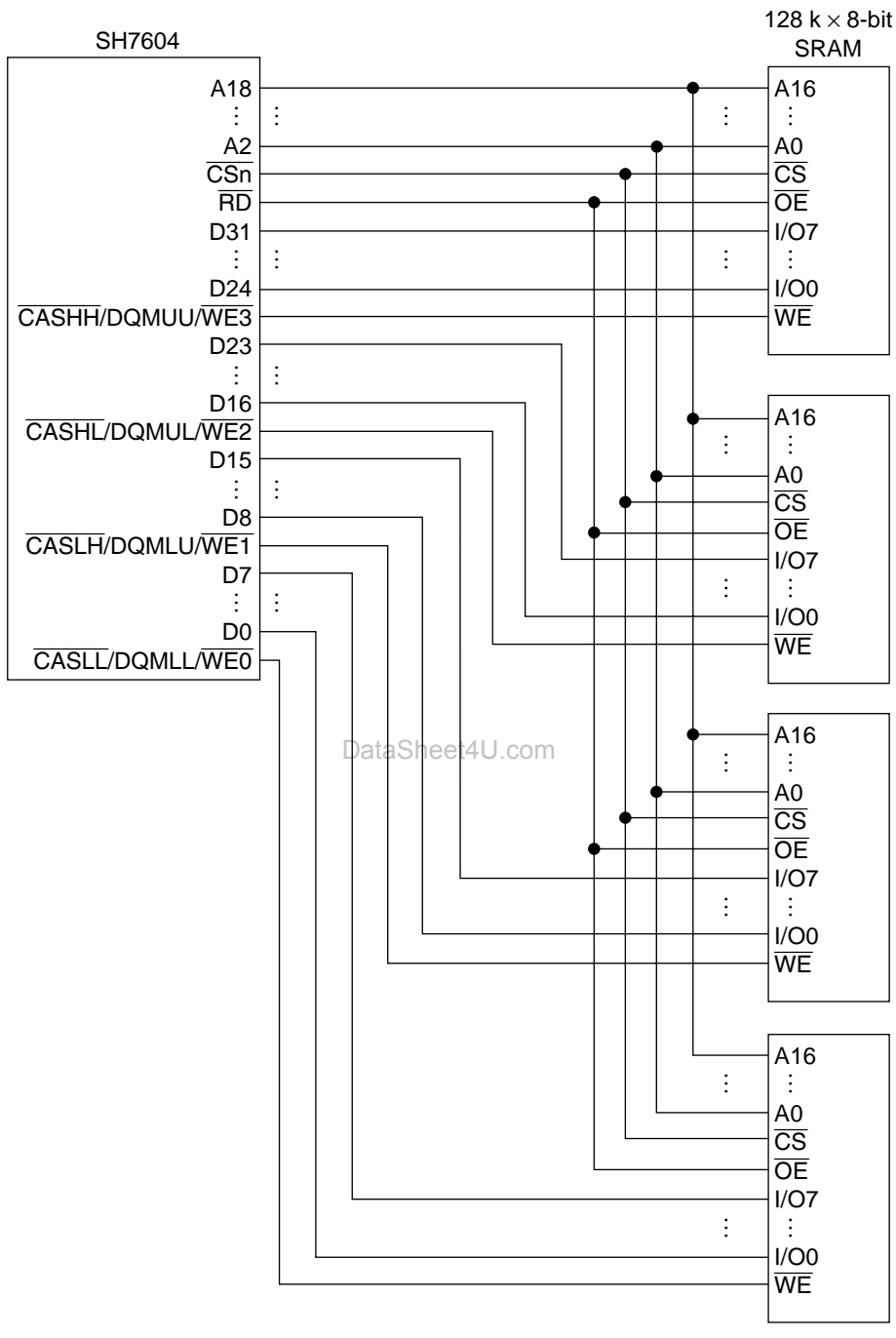

Figure 7.8 Example of 32-Bit Data Width SRAM Connection

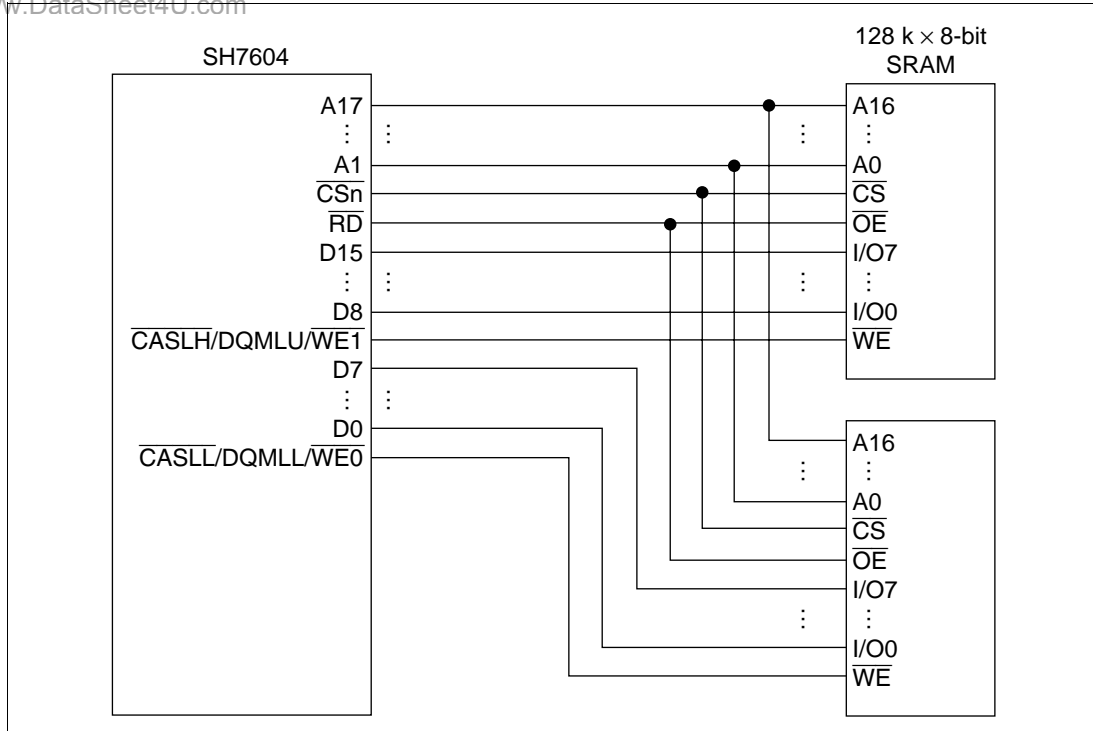

Figure 7.9 Example of 16-Bit Data Width SRAM Connection

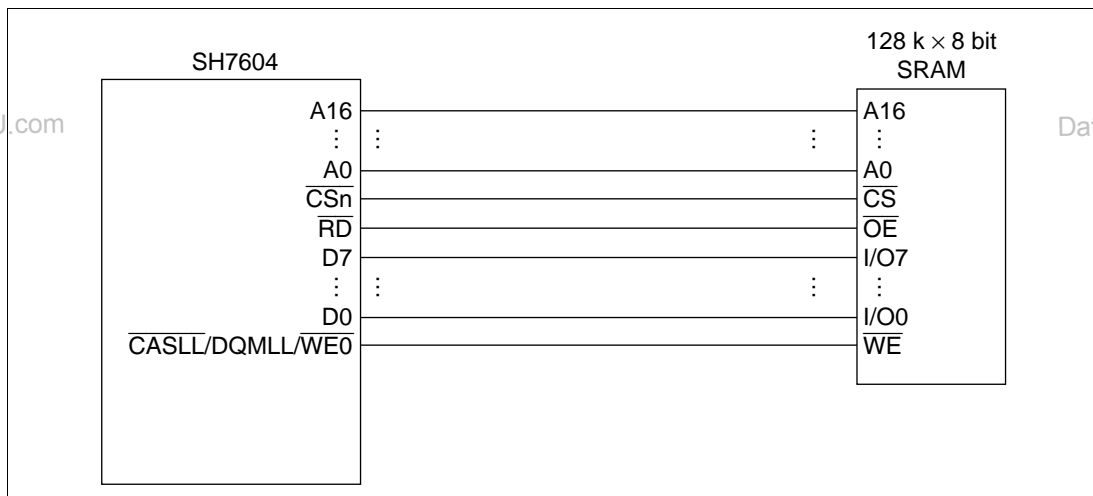

Figure 7.10 Example of 8-Bit Data Width SRAM Connection

The number of wait states inserted into ordinary space access states can be controlled using the WCR and BCR1 register settings. When the $Wn1$ and $Wn0$ wait specification bits in WCR for the given CS space are 01 or 10, software waits are inserted according to the wait specification. When $Wn1$ and $Wn0$ are 11, wait cycles are inserted according to the long wait specification bit $AnLW$ in BCR1. The long wait specification in BCR1 can be made independently for CS0 and CS1 spaces, but the same value must be specified for CS2 and CS3 spaces. All WCR specifications are independent. A T_w cycle as long as the number of specified cycles is inserted as a wait cycle at the wait timing for ordinary access space shown in figure 7.11.

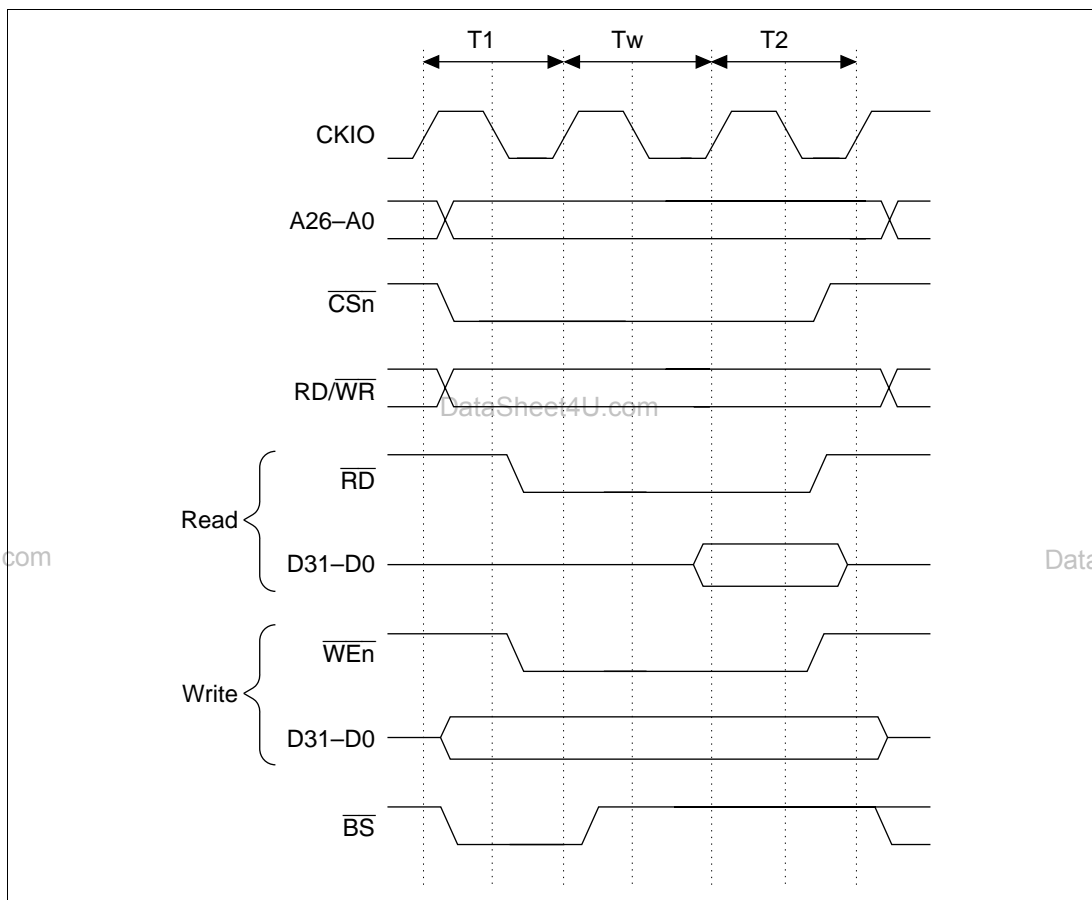
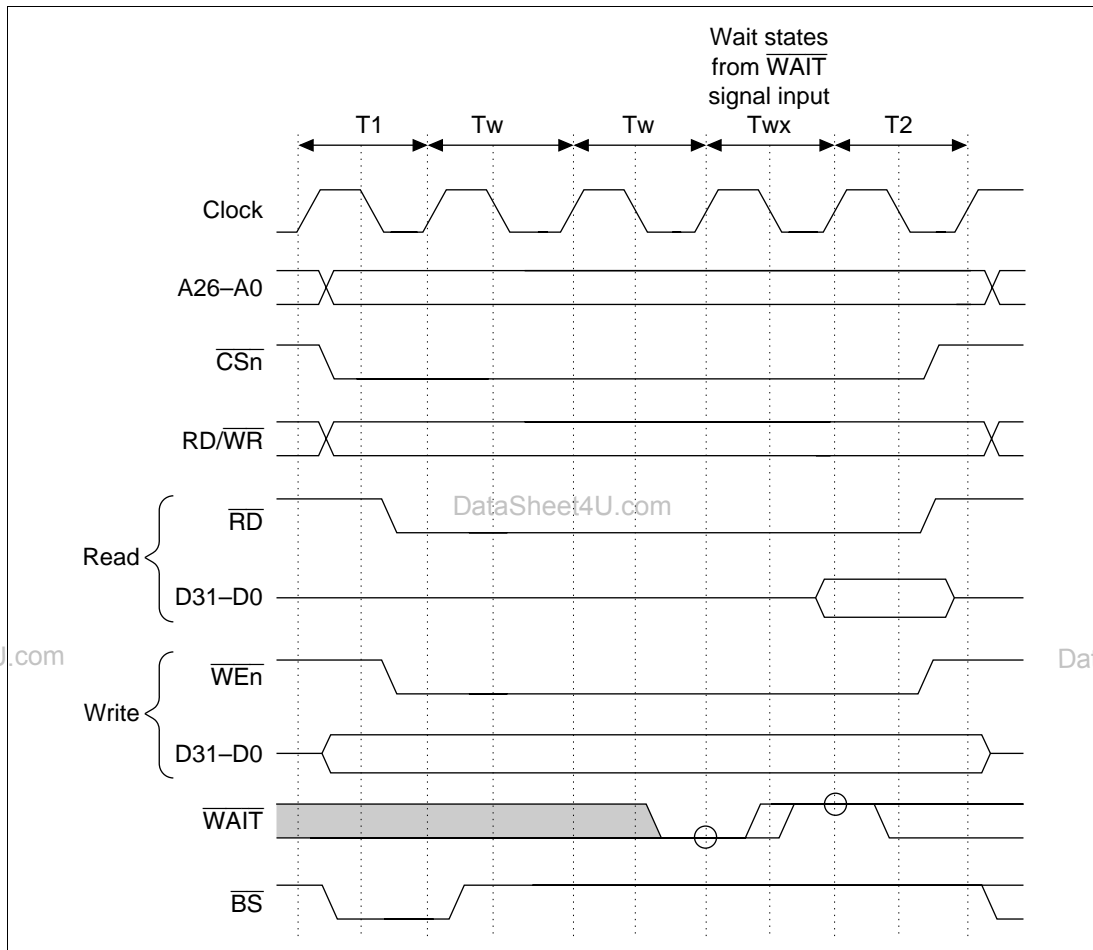

Figure 7.11 Wait Timing of Ordinary Space Access (Software Wait Only)

When the wait is specified by software using WCR, the wait input $\overline{\text{WAIT}}$ signal from outside is sampled. Figure 7.12 shows $\overline{\text{WAIT}}$ signal sampling. A 2-cycle wait is specified as a software wait. The sampling is performed when the Tw state shifts to the T2 state, so there is no effect even when the $\overline{\text{WAIT}}$ signal is asserted in the T1 cycle or the first Tw cycle. The $\overline{\text{WAIT}}$ signal is sampled at the clock rise. External waits should not be inserted, however, into word accesses of devices (such as ordinary space and burst ROM) that have an 8-bit bus width (byte-size devices). Control waits in such cases with software only.



**Figure 7.12 Wait State Timing of Ordinary Space Access
(Wait States from $\overline{\text{WAIT}}$ Signal)**

7.5 Synchronous DRAM Interface

7.5.1 Synchronous DRAM Direct Connection

2-Mbit ($128k \times 16$), 4-Mbit ($256k \times 16$), and 16-Mbit ($1M \times 16$, $2M \times 8$, and $4M \times 4$) synchronous DRAMs can be connected directly to the SH7604. All of these are internally divided into two banks. Since synchronous DRAM can be selected by the \overline{CS} signal, areas CS2 and CS3 can be connected using a common \overline{RAS} or other control signal. When the enable bits for DRAM and other memory (DRAM2–DRAM0) in BCR1 are set to 001, CS2 is ordinary space and CS3 is synchronous DRAM space. When set to 100, CS2 is synchronous DRAM space and CS3 is ordinary space. When set to 101, both CS2 and CS3 are synchronous DRAM spaces.

The supported synchronous DRAM operating mode is for burst read and single write. The burst length depends on the data bus width, comprising 4 bursts for a 32-bit width, and 8 bursts for a 16-bit width. The data bus width is specified by the SZ bit in MCR. Burst operation is always performed, so the burst enable (BE) bit in MCR is ignored.

Control signals for directly connecting synchronous DRAM are the $\overline{RAS}/\overline{CE}$, $\overline{CAS}/\overline{OE}$, $\overline{RD}/\overline{WR}$, $\overline{CS2}$ or $\overline{CS3}$, DQM_{UU}, DQM_{MU}, DQM_{LU}, DQM_{LL}, and CKE signals. Signals other than $\overline{CS2}$ and $\overline{CS3}$ are common to every area, and signals other than CKE are valid and fetched only when $\overline{CS2}$ or $\overline{CS3}$ is true. Therefore, synchronous DRAM of multiple areas can be connected in parallel. CKE is negated (to the low level); only when a self-refresh is performed otherwise it is asserted (to the high level).

DataSheet4U.com

Commands can be specified for synchronous DRAM using the $\overline{RAS}/\overline{CE}$, $\overline{CAS}/\overline{OE}$, $\overline{RD}/\overline{WR}$, and certain address signals. These commands are NOP, auto-refresh (REF), self-refresh (SELF), all-bank precharge (PALL), specific bank precharge (PRE), row address strobe/bank active (ACTV), read (READ), read with precharge (READA), write (WRIT), write with precharge (WRITA), and mode register write (MRS).

Bytes are specified using DQM_{UU}, DQM_{MU}, DQM_{LU}, and DQM_{LL}. The read/write is performed on the byte whose DQM is low. For 32-bit data, DQM_{UU} specifies $4n$ address access and DQM_{LL} specifies $4n + 3$ address access. For 16-bit data, only DQM_{LU} and DQM_{LL} are used. Figure 7.13 shows an example in which a 32-bit connection uses a $256k \times 16$ bit synchronous DRAM. Figure 7.14 shows an example with a 16-bit connection.

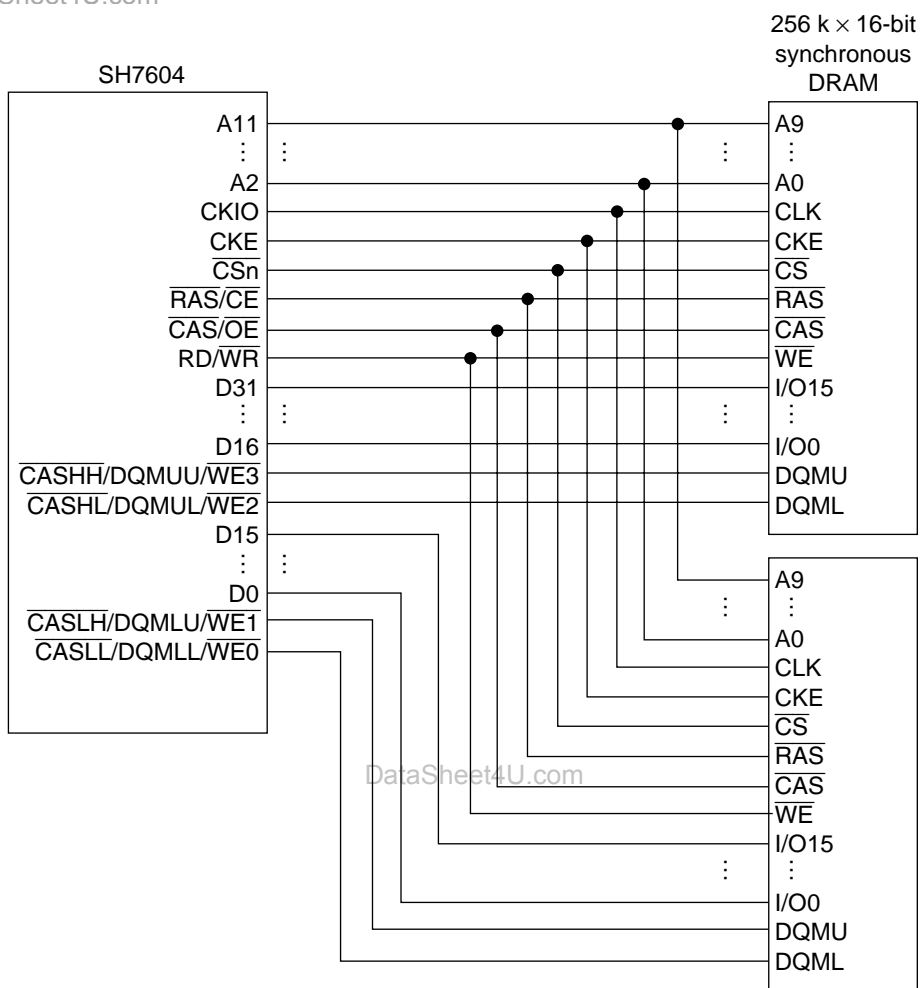

Figure 7.13 Synchronous DRAM 32-bit Device Connection

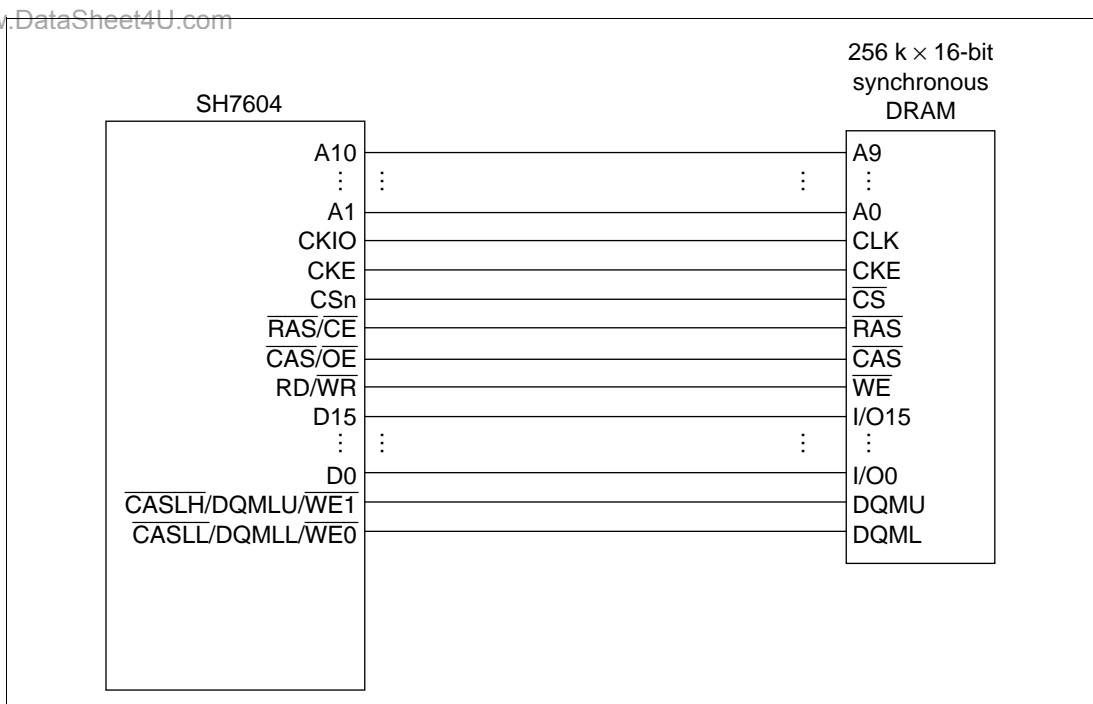

Figure 7.14 Synchronous DRAM 16-bit Device Connection

7.5.2 Address Multiplexing

DataSheet4U.com

Addresses are multiplexed according to the MCR's address multiplex specification bits AMX2–AMX0 and size specification bit SZ so that synchronous DRAMs can be connected directly without an external multiplex circuit. Table 7.4 shows the relationship between the multiplex specification bits and bit output to the address pins.

A26–A14 and A0 always output the original value regardless of multiplexing.

When $SZ = 0$, the data width on the synchronous DRAM side is 16 bits and the LSB of the device's address pins (A0) specifies word address. The A0 pin of the synchronous DRAM is thus connected to the A1 pin of the SH7604, the rest of the connection proceeding in the same order, beginning with the A1 pin to the A2 pin.

When $SZ = 1$, the data width on the synchronous DRAM side is 32 bits and the LSB of the device's address pins (A0) specifies longword address. The A0 pin of the synchronous DRAM is thus connected to the A2 pin of the SH7604, the rest of the connection proceeding in the same order, beginning with the A1 pin to the A3 pin.

Table 7.4 SZ and AMX Bits and Address Multiplex Output

Setting				External Address Pins						
SZ	AMX2	AMX1	AMX0	Output Timing	A1–A8	A9	A10	A11	A12	A13
1	0	0	0	Column address	A1–A8	A9	A10	A11	L/H ^{*1}	A21 ^{*2}
				Row address	A9–A16	A17	A18	A19	A20	A21 ^{*2}
1	0	0	1	Column address	A1–A8	A9	A10	A11	L/H ^{*1}	A22 ^{*2}
				Row address	A10–A17	A18	A19	A20	A21	A22 ^{*2}
1	0	1	0	Column address	A1–A8	A9	A10	A11	L/H ^{*1}	A23 ^{*2}
				Row address	A11–A18	A19	A20	A21	A22	A23 ^{*2}
1	0	1	1	Column address	A1–A8	A9	L/H ^{*1}	A19 ^{*2}	A12	A13
				Row address	A9–A16	A17	A18	A19 ^{*2}	A20	A21
1	1	1	1	Column address	A1–A8	A9	L/H ^{*1}	A18 ^{*2}	A12	A13
				Row address	A9–A16	A17	A17	A18 ^{*2}	A20	A21
0	0	0	0	Column address	A1–A8	A9	A10	L/H ^{*1}	A20 ^{*2}	A13
				Row address	A9–A16	A17	A18	A19	A20 ^{*2}	A21
0	0	1	1	Column address	A1–A8	L/H ^{*1}	A18 ^{*2}	A11	A12	A13
				Row address	A9–A16	A17	A18 ^{*2}	A19	A20	A21
0	1	1	1	Column address	A1–A8	L/H ^{*1}	A17 ^{*2}	A11	A12	A13
				Row address	A9–A16	A16	A17 ^{*2}	A19	A20	A21

AMX2–AMX0 settings of 100, 101 and 110 are reserved, so do not use them. When SZ = 0, the settings 001 and 010 are reserved as well, so do not use them either.

Notes: 1. L/H is a bit used to specify commands. It is fixed at L or H according to the access mode.

2. Specifies bank address.

7.5.3 Burst Reads

Figure 7.15 shows the timing chart for burst reads. In the following example, 2 synchronous DRAMs of 256k × 16 bits are connected, the data width is 32 bits and the burst length is 4. After a Tr cycle that performs ACTV command output, a READA command is called in the Tc cycle and read data is accepted at internal clock falls from Td1 to Td4. Tap is a cycle for waiting for the completion of the auto-precharge based on the READA command within the synchronous DRAM. During this period, no new access commands are issued to the same bank. Accesses of the other bank of the synchronous DRAM by another CS space are possible. Depending on the TRP specification in MCR, the SH7604 determines the number of Tap cycles and does not issue a command to the same bank during that period.

Figure 7.15 shows an example of the basic cycle. Because a slower synchronous DRAM is connected, setting WCR and MCR bits can extend the cycle. The number of cycles from the ACTV command output cycle T_r to the READA command output cycle T_c can be specified by the RCD bit in MCR. 0 specifies 1 cycle; 1 specifies 2 cycles. For 2 cycles, a NOP command issue cycle T_{rw} for the synchronous DRAM is inserted between the T_r cycle and the T_c cycle. The number of cycles between the READA command output cycle T_c and the initial read data fetch cycle T_{d1} can be specified independently for areas CS2 and CS3 between 1 cycle and 4 cycles using the W21/W20 and W31/W30 bits in WCR. The CAS latency when using bus arbitration in the partial-share master mode can be set differently for CS2 and CS3 spaces. The number of cycles at this time corresponds to the number of CAS latency cycles of the synchronous DRAM. When 2 cycles or more, a NOP command issue cycle T_w is inserted between the T_c cycle and the T_{d1} cycle. The number of cycles in the precharge completion waiting cycle T_{ap} is specified by the TRP bit in MCR. When the CAS latency is 1, a T_{ap} cycle of 1 or 2 cycles is generated. When the CAS latency is 2 or more, a T_{ap} cycle equal to the TRP specification - 1 is generated. During the T_{ap} cycle, no commands other than NOP are issued to the same bank. Figure 7.16 shows an example of burst read timing when RCD is 1, W31/W30 is 01, and TRP is 1.

With the synchronous DRAM cycle, when the bus cycle starts in ordinary space access, the \overline{BS} signal asserted for 1 cycle is asserted in each of cycles T_{d1} – T_{d4} for the purpose of the external address monitoring described in the section on bus arbitration. When another CS space is accessed after an synchronous DRAM read with a wait-between-buses specification of 0, the \overline{BS} signal may be continuously asserted. The address is updated every time data is fetched while burst reads are being performed. The burst transfer unit is 16 bytes, so address updating affects A3–A1. The access order follows the address order in 16-byte data transfers by the DMAC, but reading starts from the address + 4 so that the last missed data in the fill operation after a cache miss can be read.

When the data width is 16 bits, 8 burst cycles are required for a 16-byte data transfer. The data fetch cycle goes from T_{d1} to T_{d8} . From T_{d1} to T_{d8} , the \overline{BS} signal is asserted in every cycle.

Synchronous DRAM CAS latency is up to 3 cycles, but the CAS latency of the bus state controller can be specified up to 4. This is so that circuits containing latches can be installed between synchronous DRAMs and the SH7604.

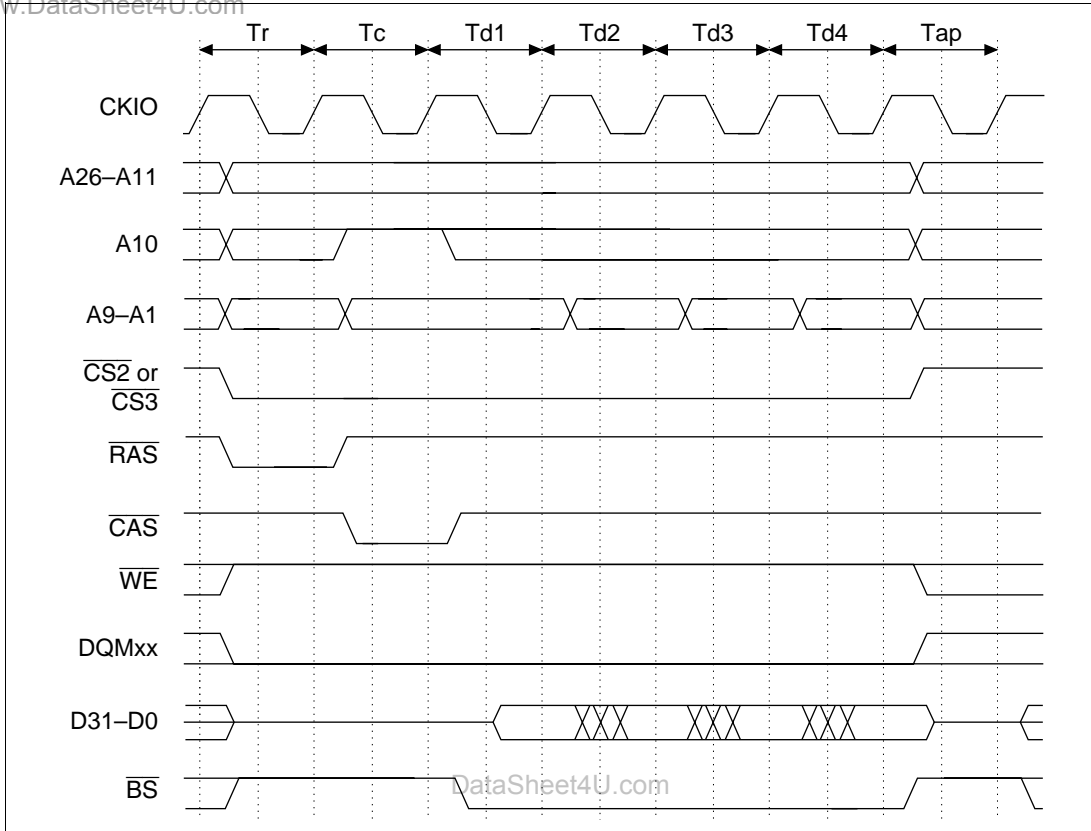

Figure 7.15 Basic Burst Read Timing (Auto-Precharge)

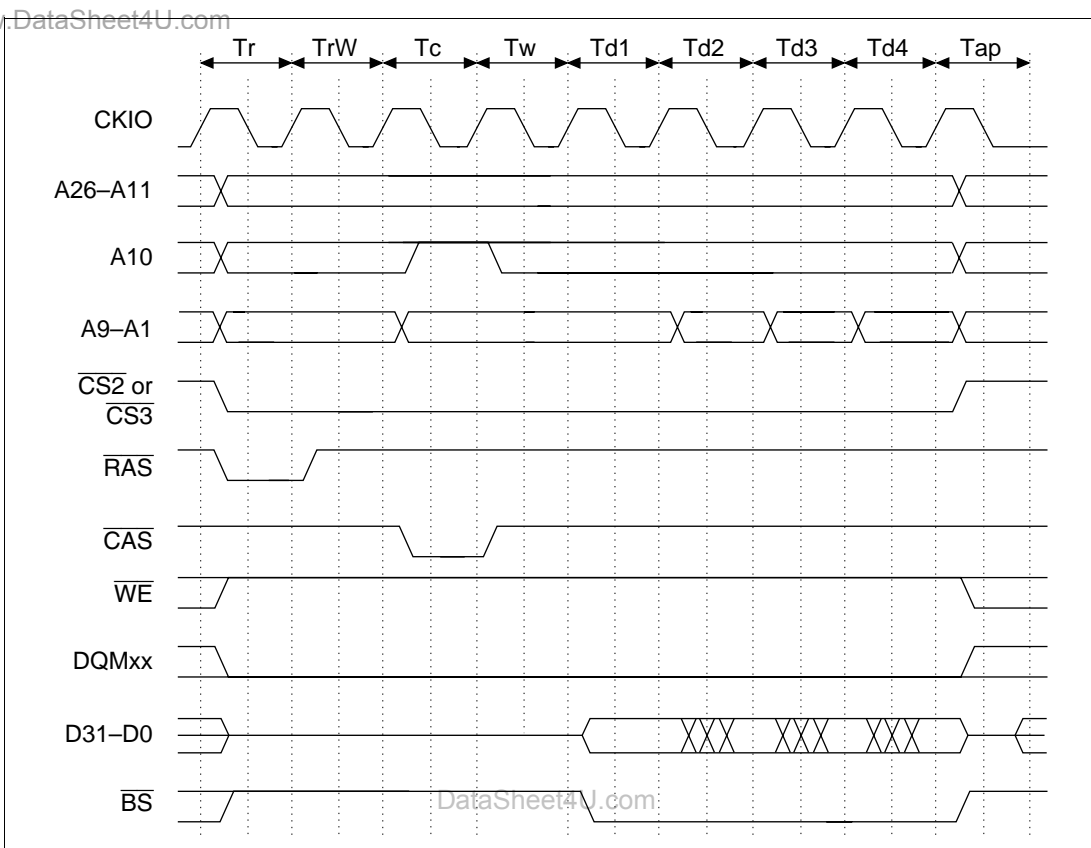

Figure 7.16 Burst Read Wait Specification Timing (Auto-Precharge)

When a cache area is accessed and there is a cache miss, the cache fill cycle is performed in 16-byte units. This means that all the data read in the burst read is valid. Since the required data when a cache-through area is accessed has a maximum length of 32 bits, however, the remaining 12 bytes are wasted. The same kind of wasted data access is produced when synchronous DRAM is specified as the source in a DMA transfer by the DMAC and the transfer unit is other than 16 bytes. Figure 7.17 shows the timing of a single address read. Because the synchronous DRAM is set to the burst read/single write mode, the read data output continues after the required data is received. To avoid data conflict, an empty read cycle is performed from Td2 to Td4 after the required data is read in Td1 and the device waits for the end of synchronous DRAM operation. In this case, data is only fetched in Td1, so the \overline{BS} signal is asserted for Td1 only.

When the data width is 16 bits, the number of burst transfers during a read is 8. \overline{BS} is asserted and data fetched in cache-through and other DMA read cycles only in the Td1 and Td2 cycles (of the 8 cycles from Td1 to Td8) for longword accesses, and only in the Td1 cycle for word or byte accesses.

Empty cycles tend to increase the memory access time, lower the program execution speed, and lower the DMA transfer speed, so it is important to avoid accessing unnecessary cache-through areas and to use data structures that enable 16-byte unit transfers by placing data on 16-byte boundaries when performing DMA transfers that specify synchronous DRAM as the source.

DataSheet4U.com

et4U.com

DataShee

DataSheet4U.com

www.DataSheet4U.com

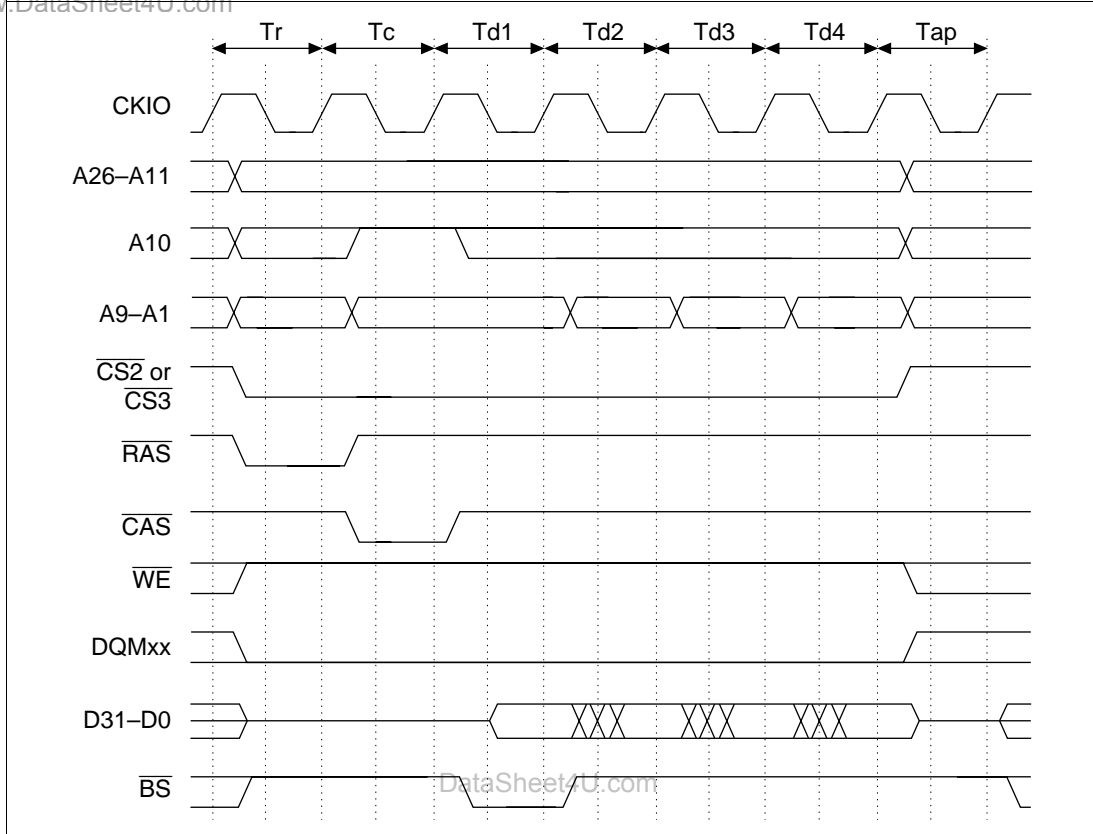

Figure 7.17 Single Read Timing (Auto-Precharge)

7.5.5 Writes

Unlike synchronous DRAM reads, synchronous DRAM writes are single writes. Figure 7.18 shows the basic timing chart for write accesses. After the ACTV command T_r , a WRITA command is issued in T_c to perform an auto-precharge. In the write cycle, the write data is output simultaneously with the write command. When writing with an auto-precharge, the bank is precharged after the completion of the write command within the synchronous DRAM, so no command can be issued to that bank until the precharge is completed. For that reason, besides a cycle T_{ap} to wait for the precharge during read accesses, the issuing of any new commands to the same bank during this period is delayed by adding a cycle T_{rw1} to wait until the precharge is started. The number of cycles in the T_{rw1} cycle can be specified using the TRWL bit in MCR.

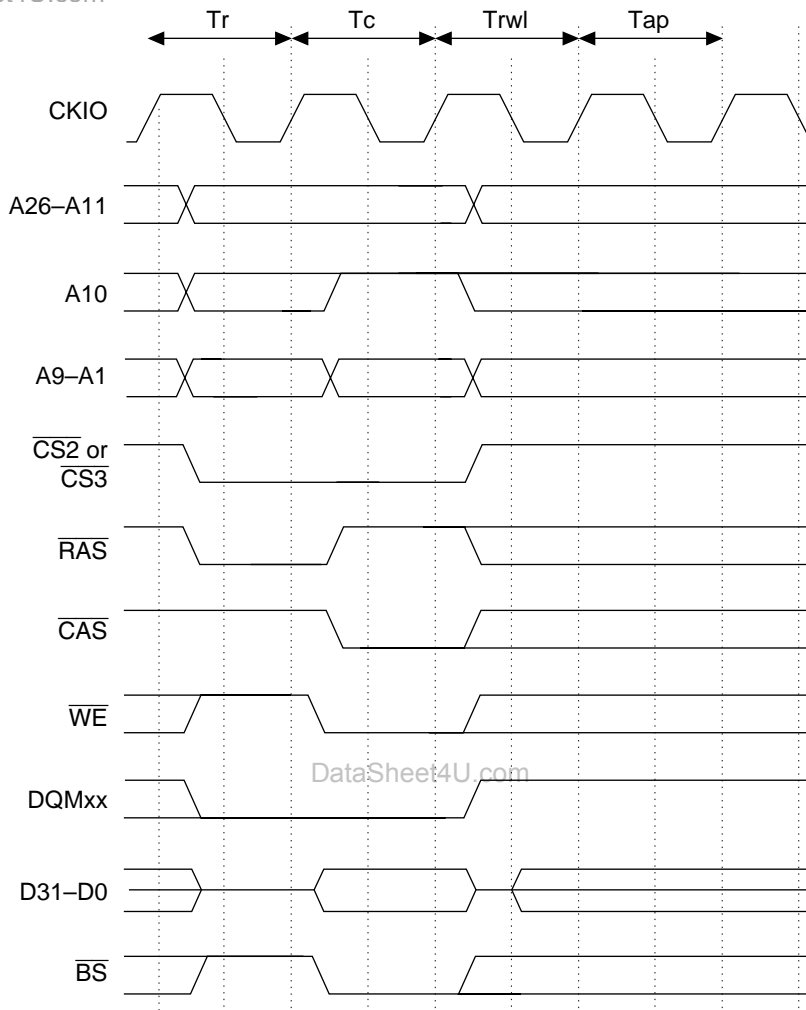

Figure 7.18 Basic Write Cycle Timing (Auto-Precharge)

7.5.6 Bank Active Function

A synchronous DRAM bank function is used to support high-speed accesses of the same row address. When the RASD bit in MCR is set to 1, read/write accesses are performed using commands without auto-precharge (READ, WRIT). In this case, even when the access is completed, no precharge is performed. When accessing the same row address in the same bank, a READ or WRIT command can be called immediately without calling an ACTV command, just like the RAS down mode of the DRAM's high-speed page mode. Synchronous DRAM is divided into two banks, so one row address in each can stay active. When the next access is to a different row address, a PRE command is called first to precharge the bank, and access is performed by an

ACTV command and READ or WRIT command, in that order, after the precharge is completed. With successive accesses to different row addresses, the precharge is performed after the access request occurs, so the access time is longer. When writing, performing an auto-precharge means that no command can be called for $t_{RWL} + t_{AP}$ cycles after a WRITA command is called. When the bank active mode is used, READ or WRIT commands can be issued consecutively if the row address is the same. This shortens the number of cycles by $t_{RWL} + t_{AP}$ for each write. The number of cycles between the issue of the precharge command and the row address strobe command is determined by the TRP bit in MCR.

Whether execution is faster when the bank active mode is used or when basic access is used is determined by the proportion of accesses to the same row address (P1) and the average number of cycles from the end of one access to the next access (t_A). When t_A is longer than t_{AP} , the delay waiting for the precharge during a read becomes invisible. If t_A is longer than $t_{RWL} + t_{AP}$, the delay waiting for the precharge also becomes invisible during writes. The difference between the bank active mode and basic access speeds in these cases is the number of cycles between the start of access and the issue of the read/write command: $(t_{RP} + t_{RCD}) \times (1 - P1)$ and t_{RCD} , respectively.

The time that a bank can be kept active, t_{RAS} , is limited. When it is not assured that this period will be provided by program execution and that another row address will be accessed without a hit to the cache, the synchronous DRAM must be set to auto-refresh and the refresh cycle must be set to the maximum value t_{RAS} or less. This enables the limit on the maximum active period for each bank to be ensured. When auto-refresh is not being used, some measure must be taken in the program to ensure that the bank does not stay active for longer than the prescribed period.

Figure 7.19 shows a burst read cycle that is not an auto-precharge cycle, figure 7.20 shows a burst read cycle to a same row address, figure 7.21 shows a burst read cycle to different row addresses, figure 7.22 shows a write cycle without auto-precharge, figure 7.23 shows a write cycle to a same row address, and figure 7.24 shows a write cycle to different row addresses.

In figure 7.20, a cycle that does nothing, T_{nop} , is inserted before the T_c cycle that issues the READ command. Synchronous DRAMs, however, have a 2 cycle latency during reads for the DQM_{xx} signals that specify bytes. If the T_c cycle is performed immediately without inserting a T_{nop} cycle, the DQM_{xx} signal for the T_{d1} cycle data output cannot be specified. This is why the T_{nop} cycle is inserted. When the CAS latency is 2 or more, the T_{nop} cycle is not inserted so that timing requirements will be met even when a DQM_{xx} signal is set after the T_c cycle.

When the SH7604 is set to the bank active mode, the access will start with figure 7.19 or figure 7.22 and repeat figure 7.20 or figure 7.23 for as long as the same row address continues to be accessed when only accesses to the respective banks of the CS3 space are considered. Accesses to other CS spaces during this period have no effect. When an access occurs to a different row address while the bank is active, figure 7.21 or figure 7.24 will be substituted for figures 7.20 and 7.23 after this is detected. Both banks will become inactive even in the bank active mode after the refresh cycle ends or after the bus is released by bus arbitration.

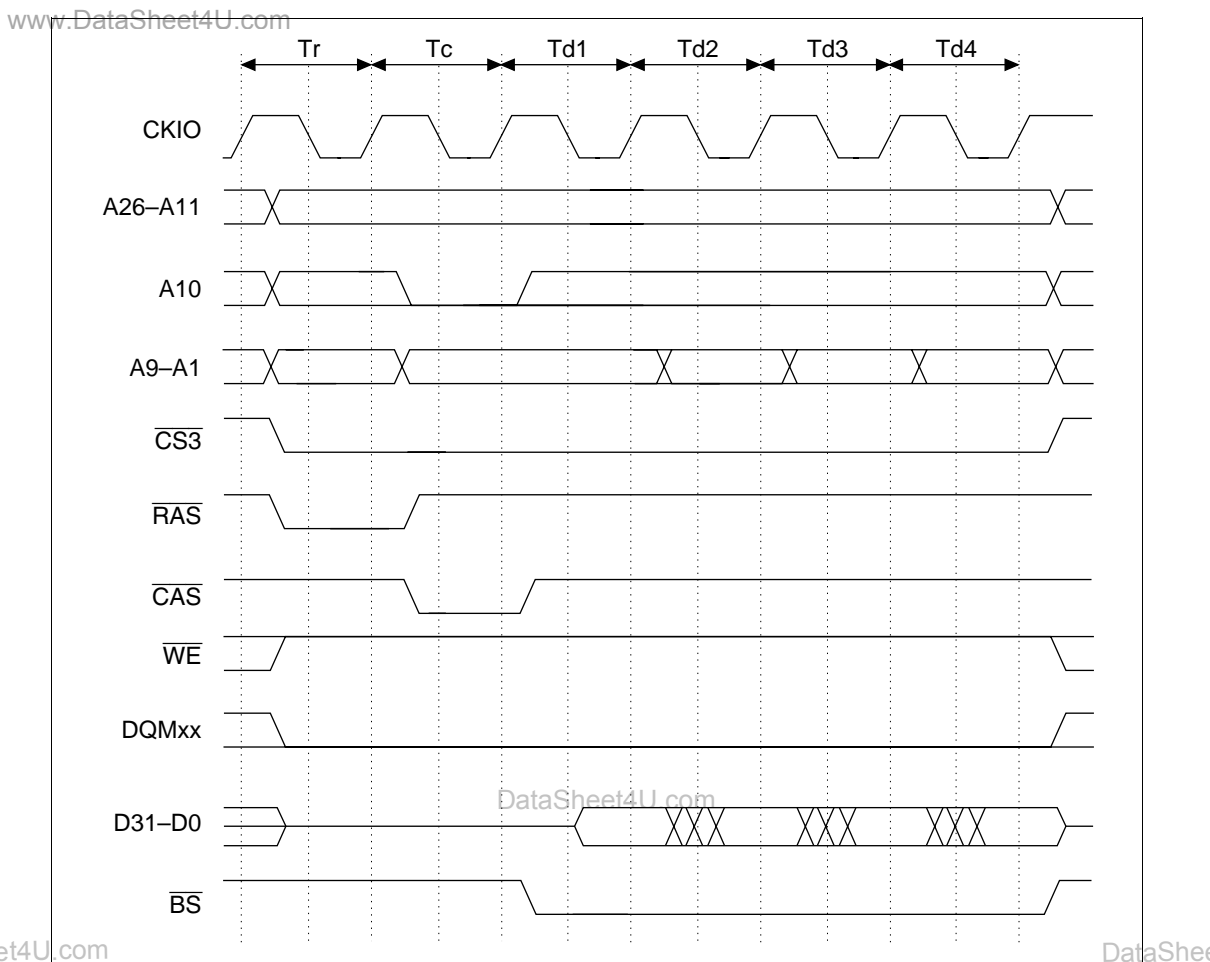

Figure 7.19 Burst Read Timing (No Precharge)

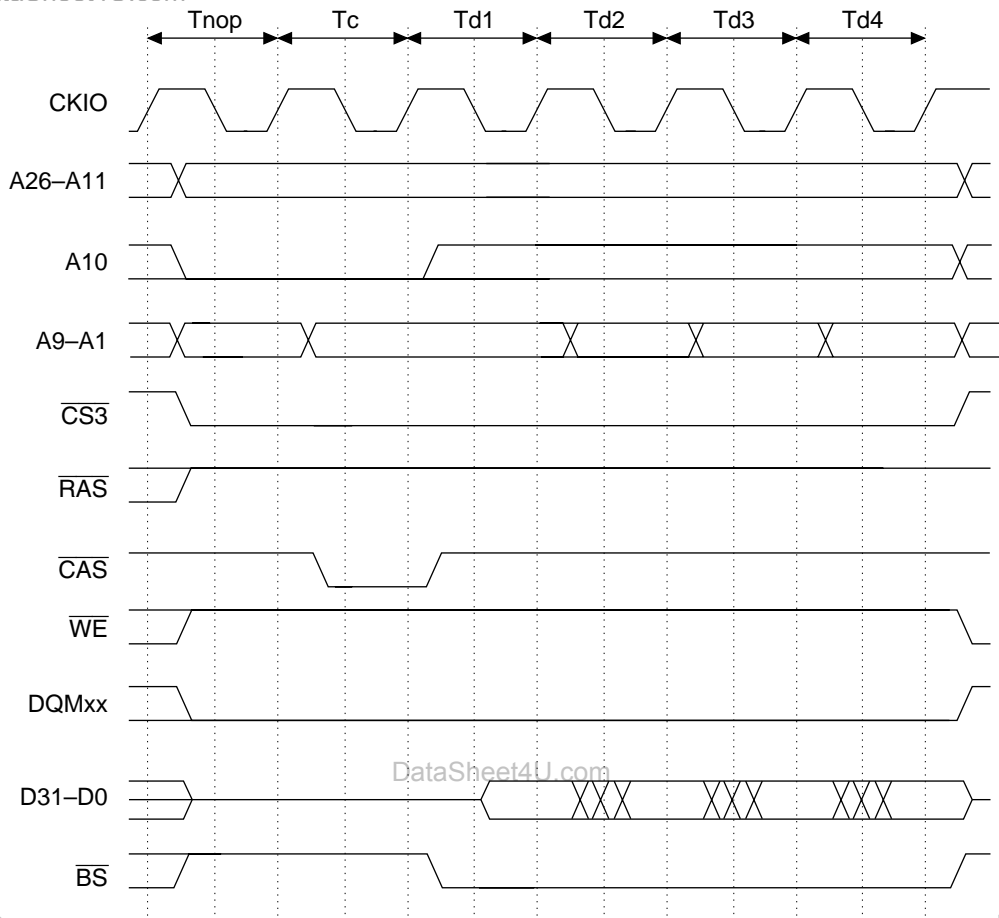

Figure 7.20 Burst Read Timing (Bank Active, Same Row Address)

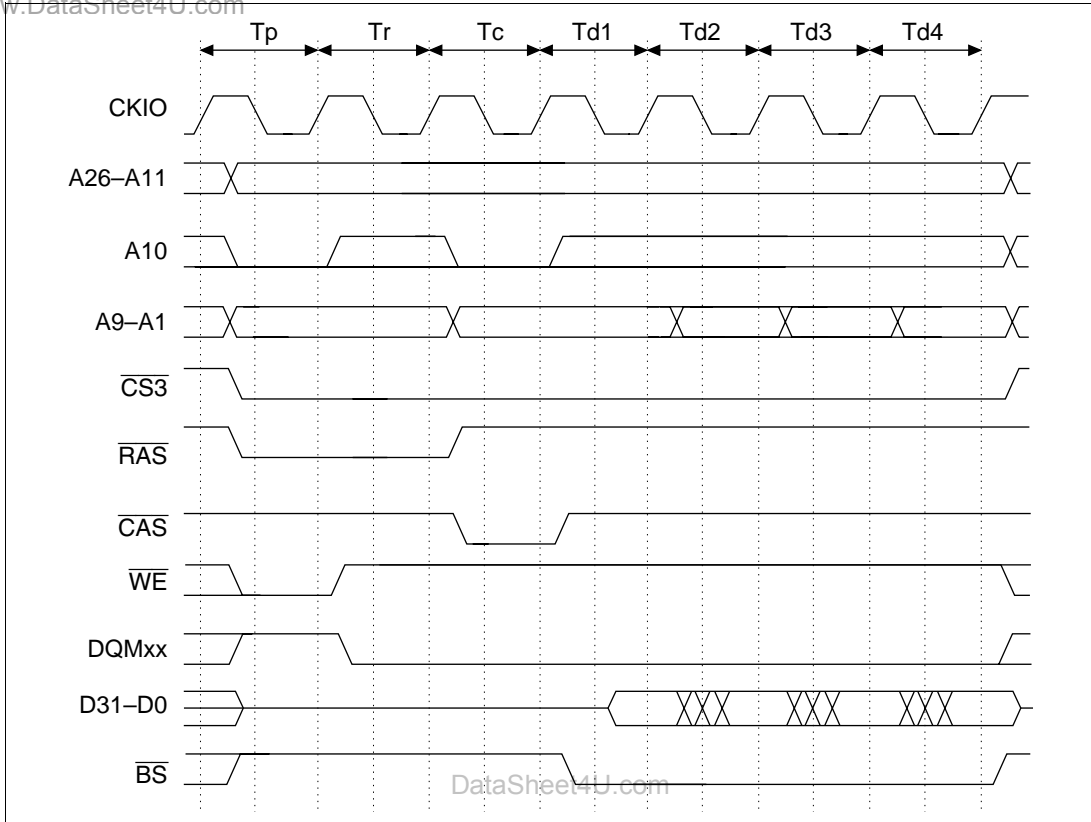

Figure 7.21 Burst Read Timing (Bank Active, Different Row Addresses)

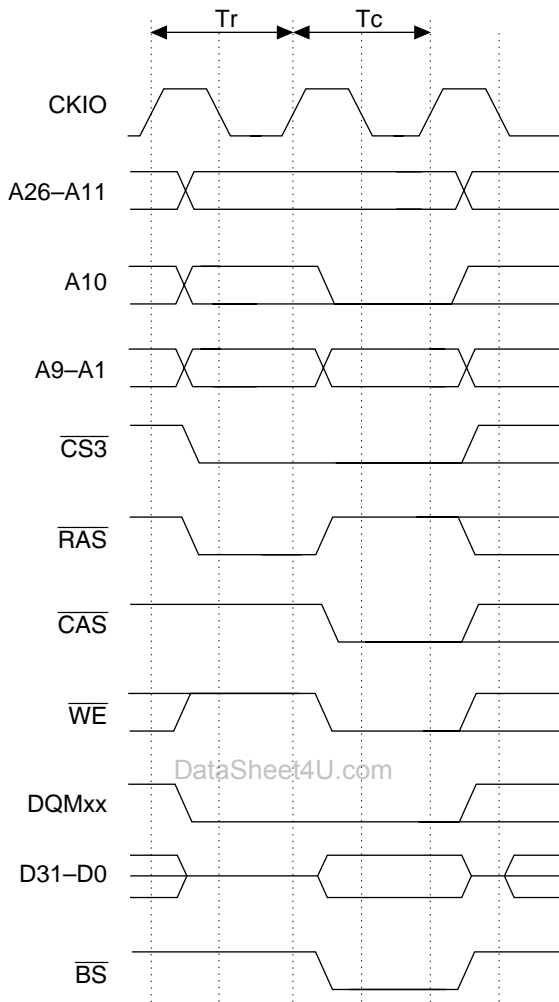

Figure 7.22 Write Timing (No Precharge)

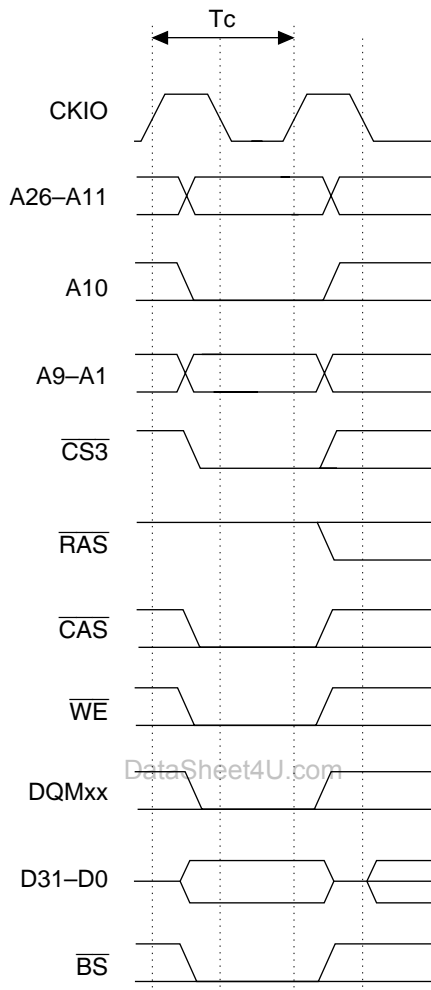

Figure 7.23 Write Timing (Bank Active, Same Row Address)

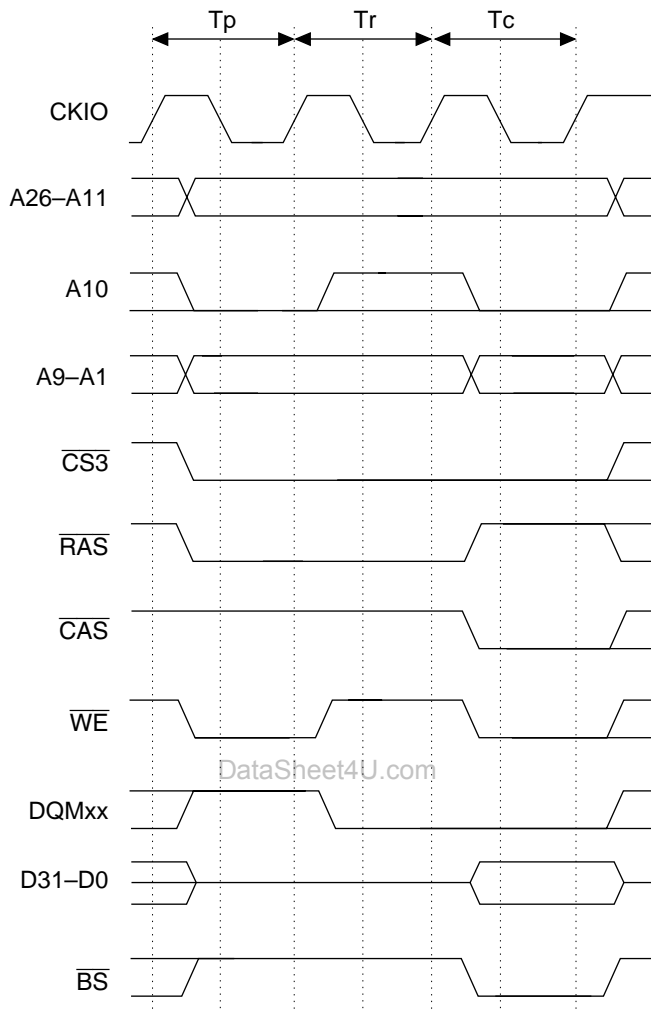

Figure 7.24 Write Timing (Bank Active, Different Row Addresses)

The bus state controller is equipped with a function to control refreshes of synchronous DRAM. Auto-refreshes can be performed by setting the MCR's RMD bit to 0 and the RFSH bit to 1. When the synchronous DRAM is not accessed for a long period of time, set the RFSH bit and RMODE bit both to 1 to initiate self-refresh mode, which uses low power consumption to retain data.

Auto-Refresh: Refreshes are performed at the interval determined by the input clock selected by the CKS2–CKS0 bits in RTCSR and the value set in RTCOR. Set the CKS2–CKS0 bits and RTCOR so that the refresh interval specifications of the synchronous DRAM being used are satisfied. First, set RTCOR, RTCNT and the RMODE and RFSH bits in MCR, then set the CKS2–CKS0 bits. When a clock is selected with the CKS2–CKS0 bits, RTCNT starts counting up from the value at that time. The RTCNT value is constantly compared to the RTCOR value and a request for a refresh is made when the two match, starting an auto-refresh. RTCNT is cleared to 0 at that time and the count up starts again. Figure 7.25 shows the timing for the auto-refresh cycle.

First, a PALL command is issued during the T_p cycle to change all the banks from active to precharge states. A REF command is then issued in the T_{rr} cycle. After the T_{rr} cycle, no new commands are output for the number of cycles specified in the TRAS bit in MCR + 2 cycles. The TRAS bit must be set to satisfy the refresh cycle time specifications (active/active command delay time) of the synchronous DRAM. When the MCR's TRP bit is 1, an NOP cycle is inserted between the T_p cycle and T_{rr} cycle.

During a manual reset, no refresh request is issued, since there is no RTCNT count-up. To perform a refresh properly, make the manual reset period shorter than the refresh cycle interval and set RTCNT to $(RTCOR - 1)$ so that the refresh is performed immediately after the manual reset is cleared.

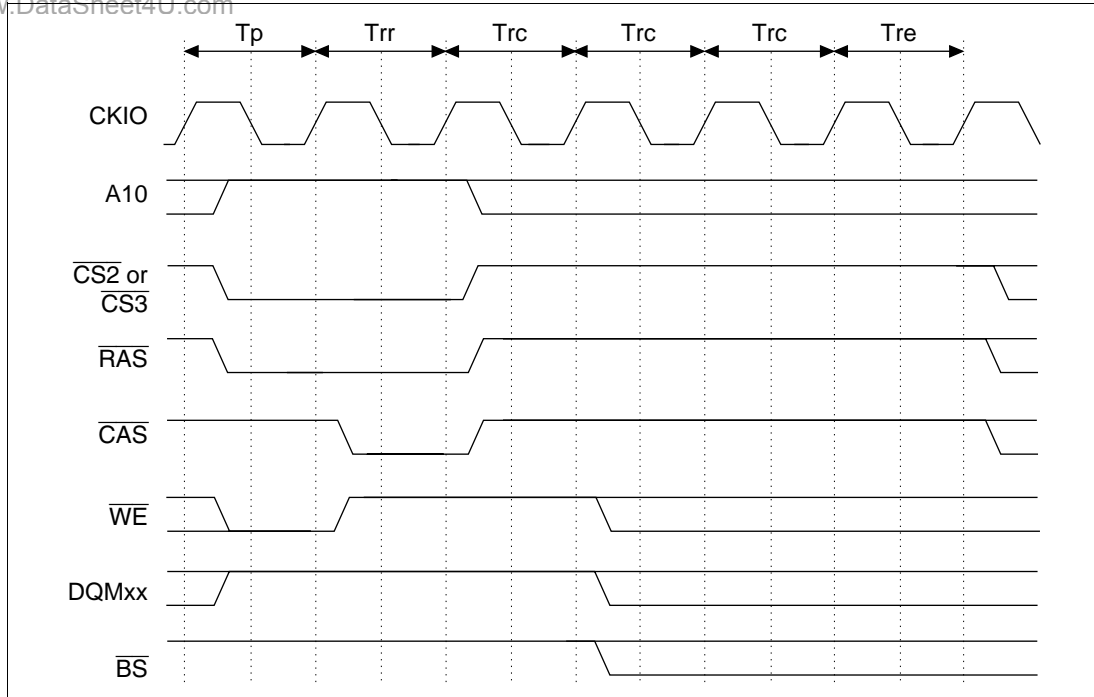

Figure 7.25 Auto-Refresh Timing

Self-Refreshes: The self-refresh mode is a type of standby mode that produces refresh timing and refresh addresses within the synchronous DRAM. It is started up by setting the RMODE and RFSH bits to 1. The synchronous DRAM is in self-refresh mode when the CKE signal level is low. During the self-refresh, the synchronous DRAM cannot be accessed. To clear the self-refresh, set the RMODE bit to 0. After self-refresh mode is cleared, issuing of commands is prohibited for the number of cycles specified in the MCR's TRAS bit + 1 cycle. Figure 7.26 shows the self-refresh timing. Immediately set the synchronous DRAM so that the auto-refresh is performed in the correct interval. This ensures a correct self-refresh clear and data holding. When self-refresh mode is entered while the synchronous DRAM is set for auto-refresh or when leaving the standby mode with a manual reset or NMI, auto-refresh can be re-started if RFSH is 1 and RMODE is 0 when the self-refresh mode is cleared. When time is required between clearing the self-refresh mode and starting the auto-refresh mode, this time must be reflected in the initial RTCNT setting. When the RTCNT value is set to RTCOR - 1, the refresh can be started immediately.

If the standby function of the SH7604 is used after the self-refresh is set to enter the standby mode, the self-refresh state continues; the self-refresh state will also be maintained after returning from a standby using an NMI.

A manual reset cannot be used to exit the self-refresh state either. During a power-on reset, the bus state controller register is initialized, so the self-refresh state is ended.

Refresh Requests and Bus Cycle Requests: When a refresh request occurs while a bus cycle is executing, the refresh will not be executed until the bus cycle is completed. When a refresh request occurs while the bus is released using the bus arbitration function, the refresh will not be executed until the bus is recaptured. If RTCNT and RTCOR match and a new refresh request occurs while waiting for the refresh to execute, the previous refresh request is erased. To make sure the refresh executes properly, be sure that the bus cycle and bus capture do not exceed the refresh interval.

If a bus arbitration request occurs during a self-refresh, the bus is not released until the self-refresh is cleared. During a self-refresh, the slave chips halt if there is a master-slave structure.

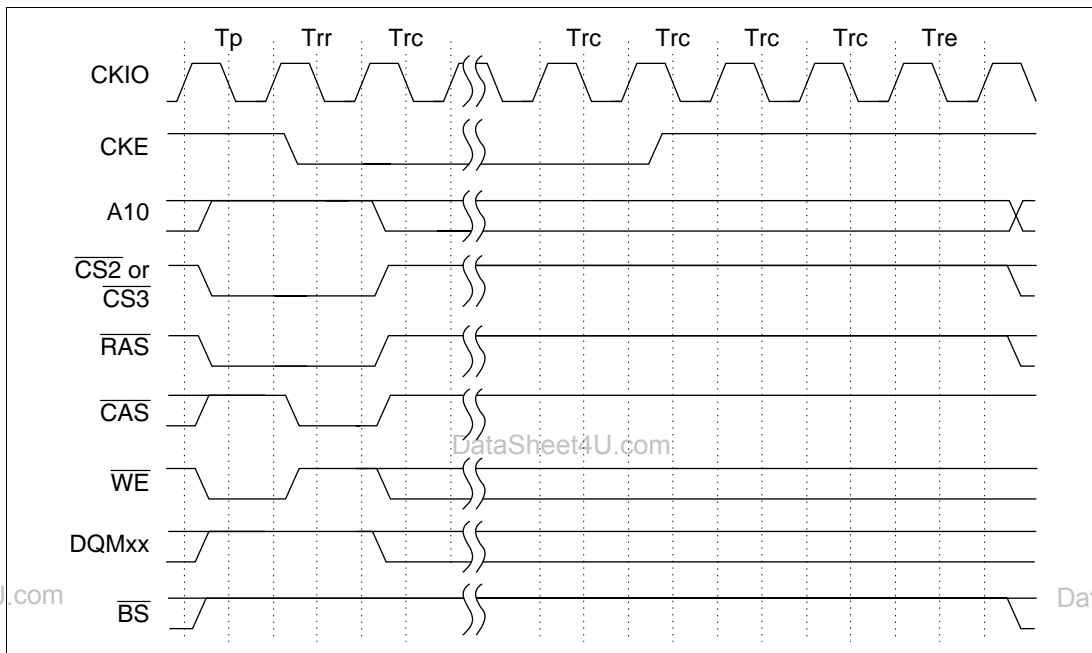

Figure 7.26 Self-Refresh Timing

7.5.8 Power-On Sequence

To use synchronous DRAM, the mode must first be set after the power is turned on. To properly initialize the synchronous DRAM, the synchronous DRAM mode register must be written to after the registers of the bus state controller have first been set. The synchronous DRAM mode register is set using a combination of the $\overline{\text{RAS}}/\overline{\text{CE}}$, $\overline{\text{CAS}}/\overline{\text{OE}}$ and $\text{RD}/\overline{\text{WR}}$ signals. They fetch the value of the address signal at that time. If the value to be set is X, the bus state controller operates by writing to address X + H'FFFF8000 from the CPU, which allows the value X to be written to the synchronous DRAM mode register. Data is ignored at this time, but the mode is written using word as the size. Write any data in word size to the following addresses to select the burst read single write supported by the SH7604, a CAS latency of 1 to 3, a sequential wrap type, and a burst length of 8 or 4 (depending on whether the width is 16 bits or 32 bits).

For 16 bits:	CAS latency 1	H'FFFF8426
	CAS latency 2	H'FFFF8446
	CAS latency 3	H'FFFF8466
For 32 bits:	CAS latency 1	H'FFFF8848
	CAS latency 2	H'FFFF8888
	CAS latency 3	H'FFFF88C8

Figure 7.27 shows the mode register setting timing.

Writing to address X + H'FFFF8000 first issues an all-bank precharge command (PALL) in the T_p cycle, then issues a mode register write command in the T_{mw} cycle. When the TRP bit in MCR is set to 1, a single idle cycle is inserted between the T_p cycle and the T_{mw} cycle.

Before setting the mode register, an idle time of 100 μs (differs by memory manufacturer) must be assured after the power required by the synchronous DRAM is turned on. When the pulse width of the reset signal is longer than the idle time, the mode register may be set immediately without problem. At least the number of dummy auto-refresh cycles specified by the manufacturer (usually 8 must be executed). After setting auto-refresh, it is usual for this to occur naturally during the various initializations, but to make sure, the interval at which refresh requests are generated can be shortened only while the dummy cycles are executing. Because the address counter within the synchronous DRAM is not initialized when auto-refresh is used during single read or write accesses, an auto-refresh cycle must always be used.

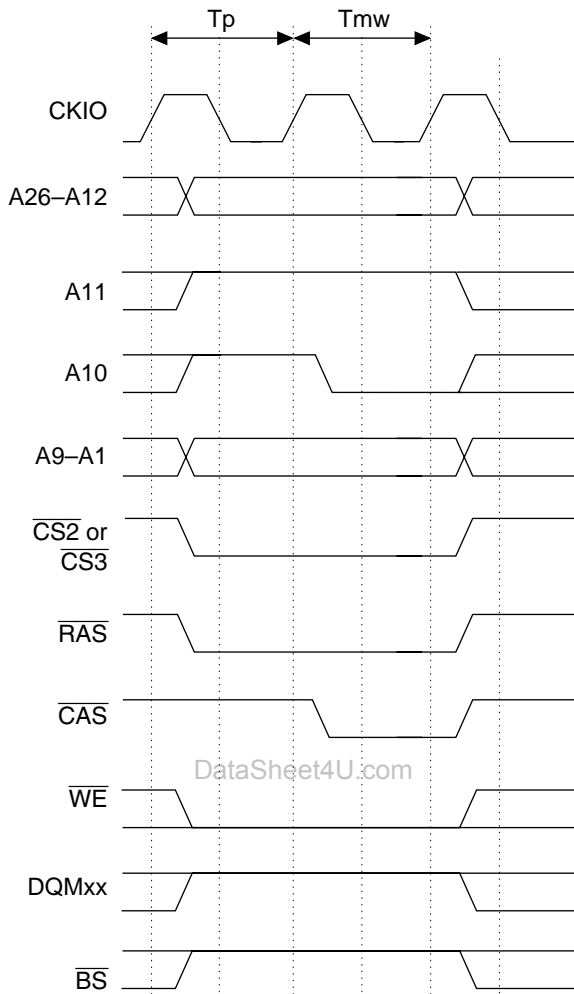

Figure 7.27 Synchronous DRAM Mode Write Timing

7.5.9 Phase Shift by PLL

The signals for synchronous DRAM interfaces change in the SH7604 at the rising edge of the internal clock. Read data is fetched on the falling edge of an internal clock. Sampling of the signals input by the synchronous DRAM and output of the read data, however, starts at the rising edge of the external clock (figure 7.28).

When the internal clock of the SH7604 and external clock are synchronized, signal transmission from the SH7604 to the synchronous DRAM has a 1 cycle margin. The transmission of read data from the synchronous DRAM to the SH7604, however, is much tighter: only 1/2 cycle, including the synchronous DRAM access time. When a clock system is connected without a means of synchronization such as an on-chip PLL, transmission from the SH7604 to the synchronous DRAM takes 1 cycle less the delay time of the clock system and transmission from the synchronous DRAM to the SH7604 takes 1/2 cycle plus the clock system delay time. The clock system delay time depends on the power supply voltage, temperature, and manufacturing variance, so it has a fairly wide range. When the phase of the internal clock of the SH7604 is delayed using a PLL that delays the phase 90 degrees relative to external clocks, transmission from the SH7604 to the synchronous DRAM and transmission from the SH7604 to the synchronous DRAM each take 3/4 cycle.

Given this, using a clock whose phase is shifted 90 degrees from the external clock using a PLL as the internal clock can ensure a margin of safety.

When using a PLL, it is important to note that synchronous DRAM does not contain an on-chip PLL. When using the external clock input clock mode, instability in the clock supplied from outside can cause shifts in phase, so a synchronization settling time in the SH7604's on-chip PLL is needed to equalize the SH7604's internal clock and the external clock. During this synchronization settling time, the internal clock of the synchronous DRAM and the internal clock of the SH7604 will not always operate in perfect synchronization. To ensure the synchronous DRAM and SH7604 operate properly, be sure that the external clock supplied is not unstable.

a. Phase Shifted 90° by PLL

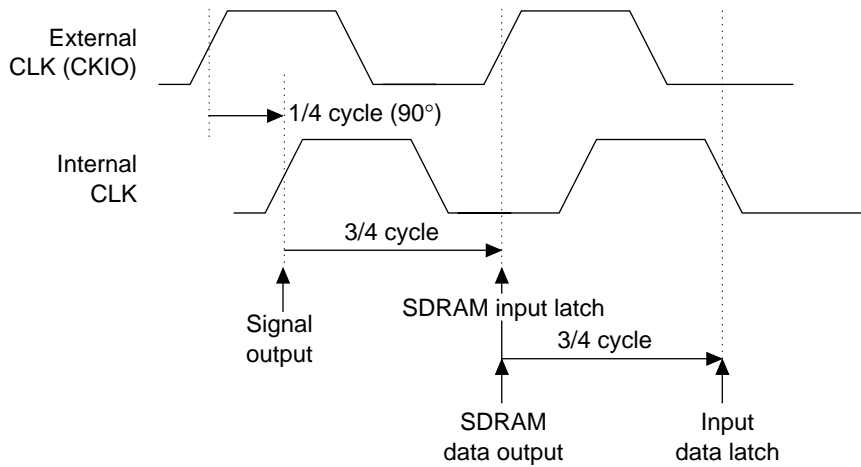

b. Phase Shift Using PLL is 0

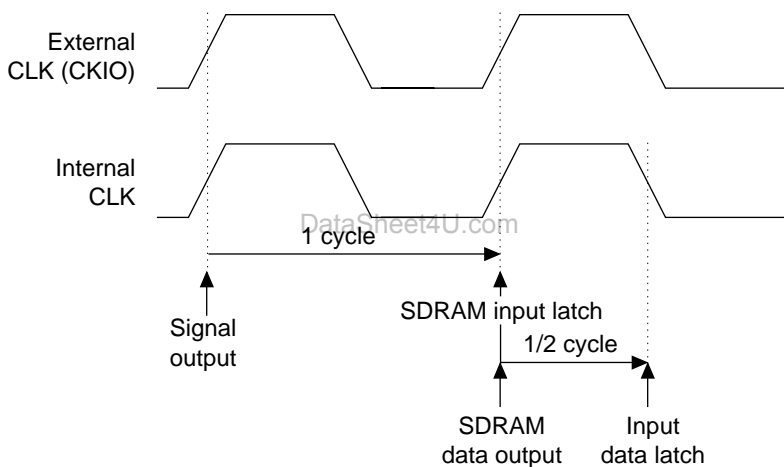

Figure 7.28 Phase Shift by PLL

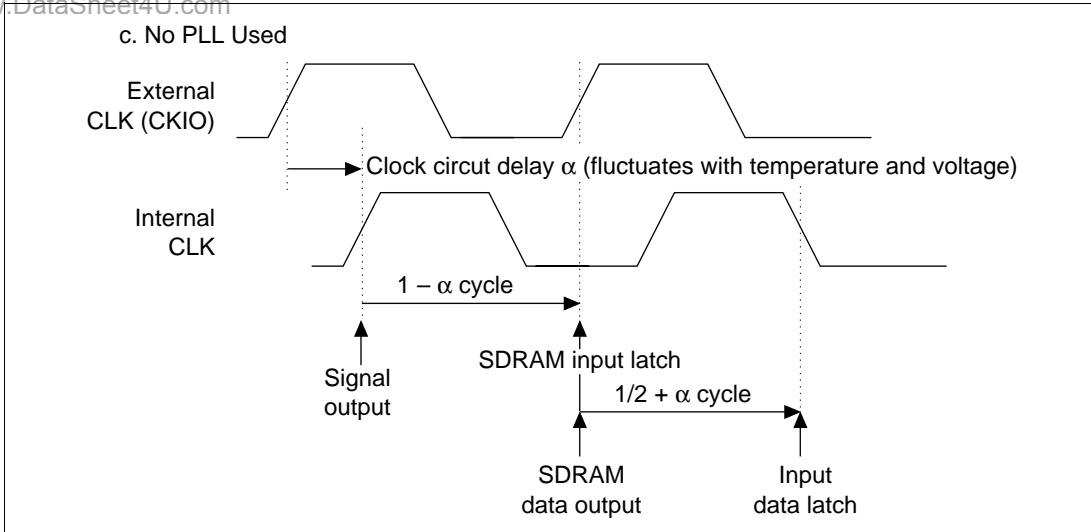

Figure 7.28 Phase Shift by PLL (cont)

7.6 DRAM Interface

7.6.1 DRAM Direct Connection

When the DRAM and other memory enable bits (DRAM2–DRAM0) in BCR1 are set to 010, the CS3 space becomes DRAM space, and a DRAM interface function can be used to directly connect the SH7604 to DRAM.

The data width of an interface can be 16 or 32 bits (figures 7.29 and 7.30). Two-CAS 16-bit DRAMs can be connected, since $\overline{\text{CAS}}$ is used to control byte access. The RAS, $\overline{\text{CASHH}}$, $\overline{\text{CASHL}}$, $\overline{\text{CASLH}}$, $\overline{\text{CASLL}}$, and RD/WR signals are used to connect the DRAM. When the data width is 16 bits, $\overline{\text{CASHH}}$ and $\overline{\text{CASHL}}$ are not used. In addition to ordinary read and write access, burst access using high-speed page mode is also supported.

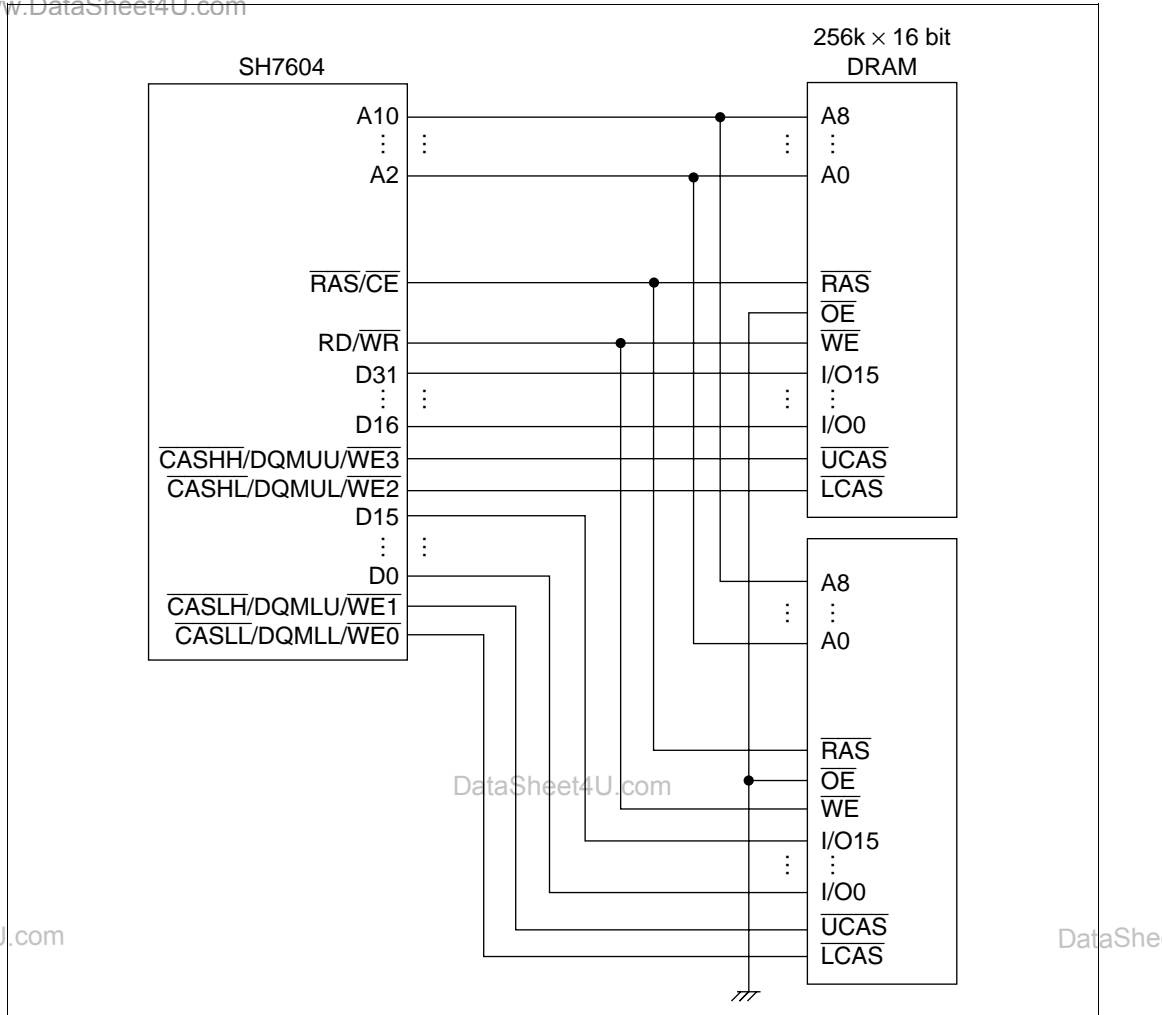

Figure 7.29 Example of DRAM Connection (32-Bit Data Width)

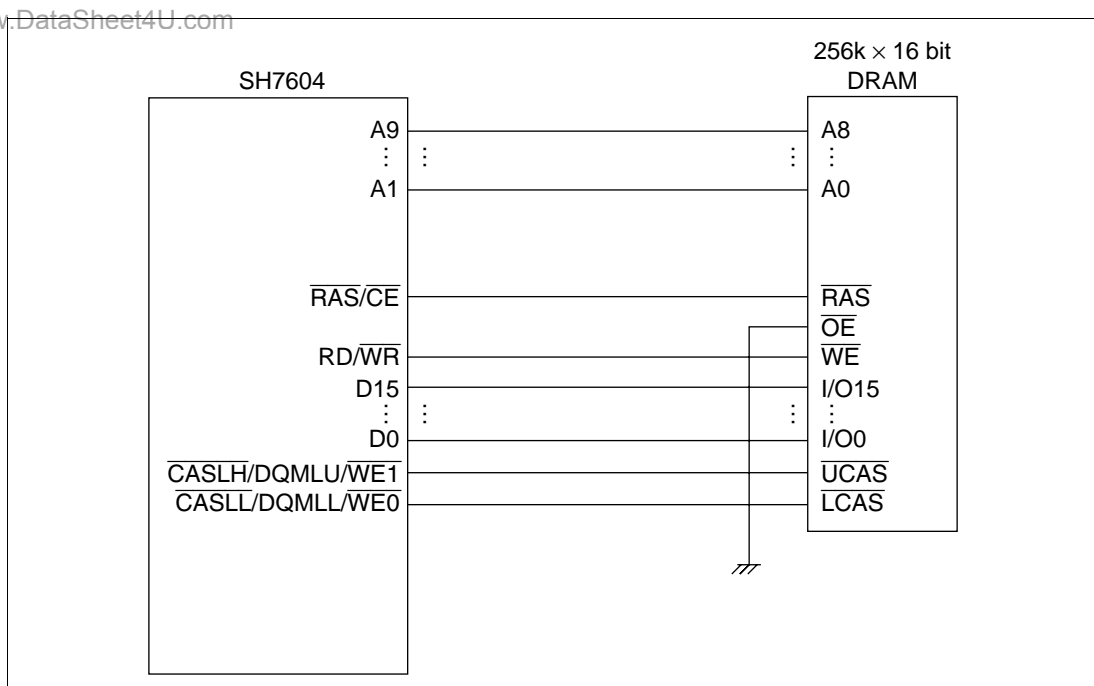

Figure 7.30 Example of DRAM Connection (16-Bit Data Width)

7.6.2 Address Multiplexing

DataSheet4U.com

When the CS3 space is set to DRAM, addresses are always multiplexed. This allows DRAMs that require multiplexing of row and column addresses to be connected directly to SH7604 microprocessors without additional multiplexing circuits. There are four ways of multiplexing, which can be selected using the MCR's AMX1–AMX0 bits. Table 7.5 illustrates the relationship between the AMX1–AMX0 bits and address multiplexing. Address multiplexing is performed on address output pins A13–A1. The original addresses are output to pins A26–A14. During DRAM accesses, AMX2 is reserved, so set it to 0.

Table 7.5 Relationship between AMX1–AMX0 and Address Multiplexing

AMX1	AMX0	No. of Column Address Bits	Row Address Output	Column Address Output
0	0	8 bits	A21–A9	A13–A1
	1	9 bits	A22–A10	A13–A1
1	0	10 bits	A23–A11	A13–A1
	1	11 bits	A24–A12	A13–A1

The basic timing of a DRAM access is 3 cycles. Figure 7.31 shows the basic DRAM access timing. T_p is the precharge cycle, T_r is the RAS assert cycle, T_{c1} is the CAS assert cycle, and T_{c2} is the read data fetch cycle. When accesses are consecutive, the T_p cycle of the next access overlaps the T_{c2} cycle of the previous access, so accesses can be performed in a minimum of 3 cycles each.

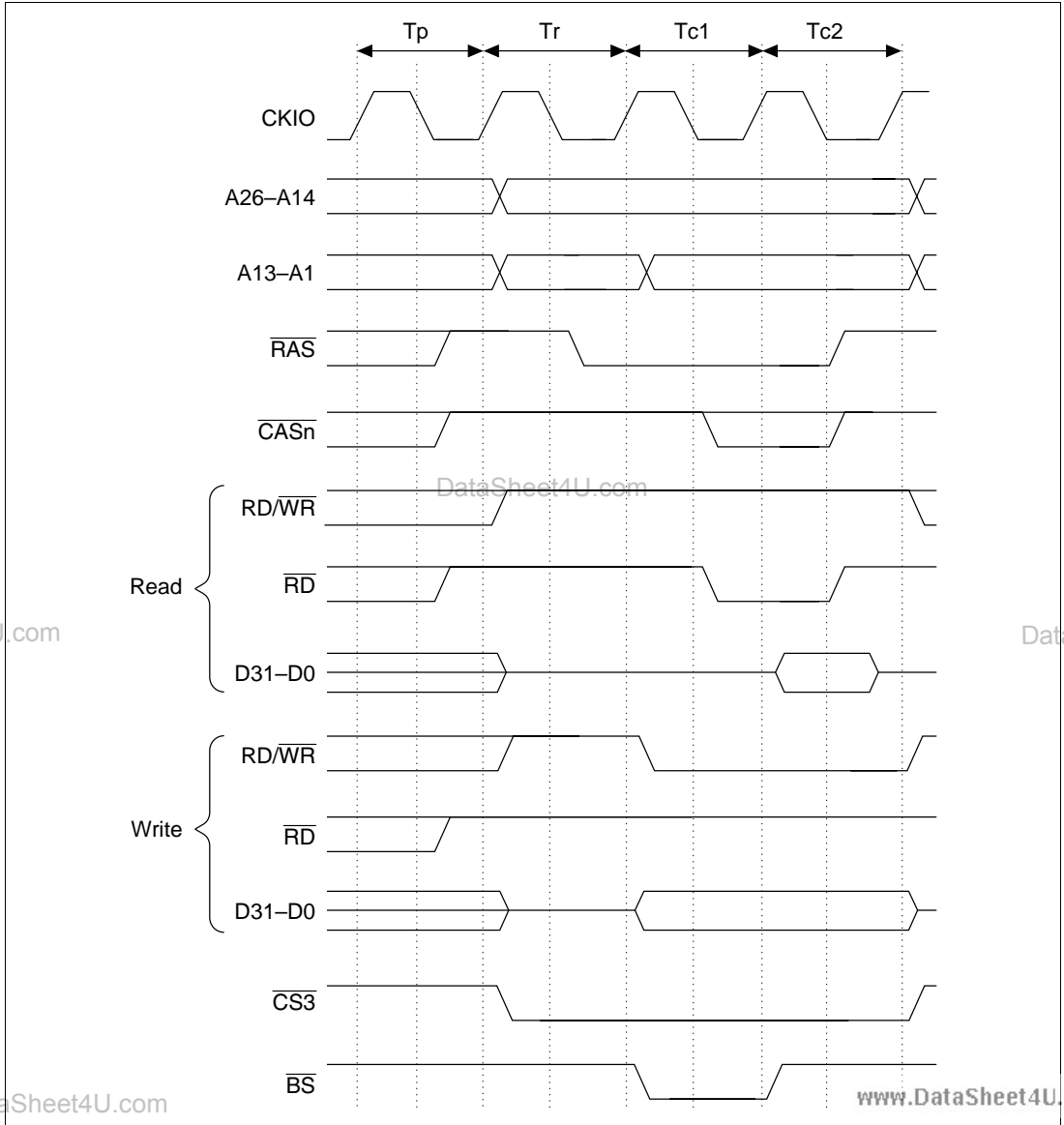

Figure 7.31 Basic Access Timing

When the clock frequency is raised, 1 cycle may not always be sufficient for all states to end, as in basic access. Setting bits in WCR and MCR enables the state to be lengthened. Figure 7.32 shows an example of lengthening a state using settings. The T_p cycle (which ensures a sufficient RAS precharge time) can be extended to 2 cycles by insertion of a T_{pw} cycle by means of the TRP bit in MCR. The number of cycles between RAS assert and CAS assert can be extended to 2 cycles by inserting a T_r cycle by means of the RCD bit in MCR. The number of cycles from CAS assert to the end of access can be extended from 1 cycle to 3 cycles by setting the W31/W30 bits in WCR. When a value other than 00 is set in W31 and W30, the external wait pin $\overline{\text{WAIT}}$ is also sampled, so the number of cycles is further increased. Figure 7.33 shows the timing of wait state control using the $\overline{\text{WAIT}}$ pin. In either case, when consecutive accesses occur, the T_p cycle of one access overlaps the T_{c2} cycle of the previous access.

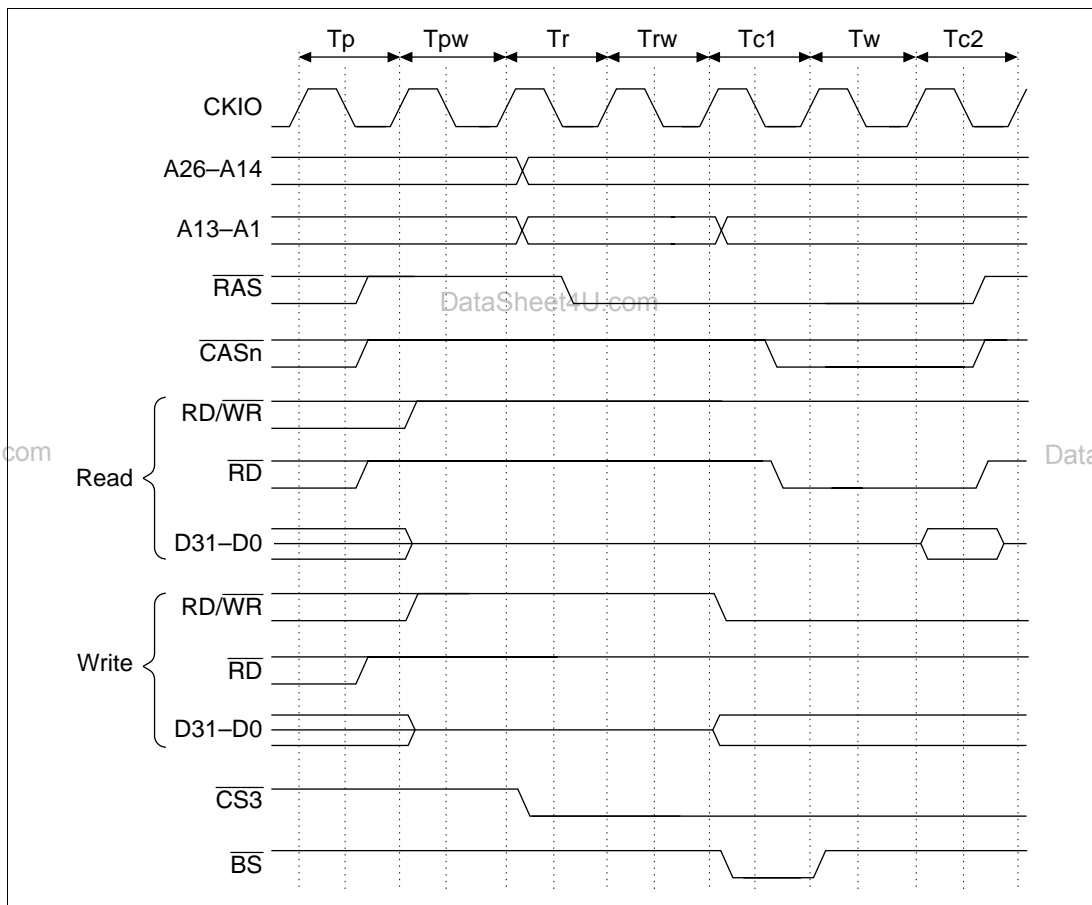

Figure 7.32 Wait State Timing

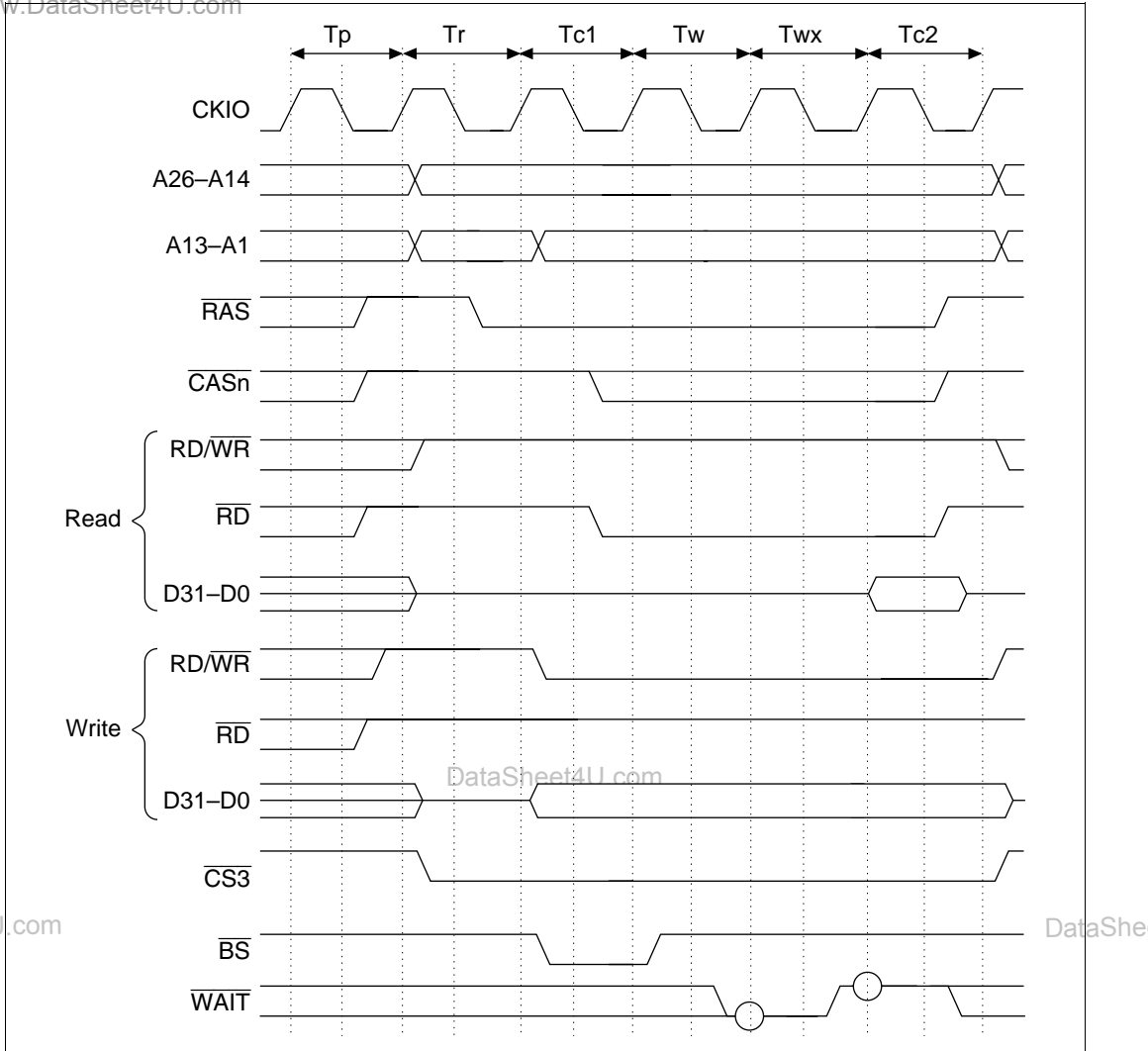

Figure 7.33 External Wait State Timing

7.6.5 Burst Access

In addition to the ordinary mode of DRAM access, in which row addresses are output at every access and data is then accessed, DRAM also has a high-speed page mode for use when continuously accessing the same row that enables fast access of data by changing only the column address after the row address is output. Select ordinary access or high-speed page mode by setting the burst enable bit (BE) in MCR. Figure 7.34 shows the timing of burst operation in high-speed page mode. When performing burst access, cycles can be inserted using the wait state control function.

The SH7604 has an address comparator to detect matches of row addresses in burst mode. When this function is used and the BE bit in MCR is set to 1, setting the MCR's RASD bit (which specifies RAS down mode) to 1 places the SH7604 in RAS down mode, which leaves the $\overline{\text{RAS}}$ signal asserted. Since the $\overline{\text{CASHH}}$, $\overline{\text{CASHL}}$, $\overline{\text{CASLH}}$ and $\overline{\text{CASLL}}$ signals are shared with $\overline{\text{WE3}}$, $\overline{\text{WE2}}$, $\overline{\text{WE1}}$ and $\overline{\text{WE0}}$ of ordinary space, however, write cycles to ordinary space during RAS down mode will simultaneously initiate an erroneous write access to the DRAM. This means that when no external devices that write to other than DRAM are connected, a DRAM can be directly interfaced using RAS down mode. When RAS down mode is used, the refresh cycle must be less than the maximum DRAM RAS assert time t_{RAS} when the refresh cycle is longer than the t_{RAS} maximum.

When an external circuit is added to keep the $\overline{\text{CASHH}}$, $\overline{\text{CASHL}}$, $\overline{\text{CASLH}}$, and $\overline{\text{CASLL}}$ signals connected to the DRAM asserted only when the CS3 level is low, there are no restrictions on the use of RAS down mode.

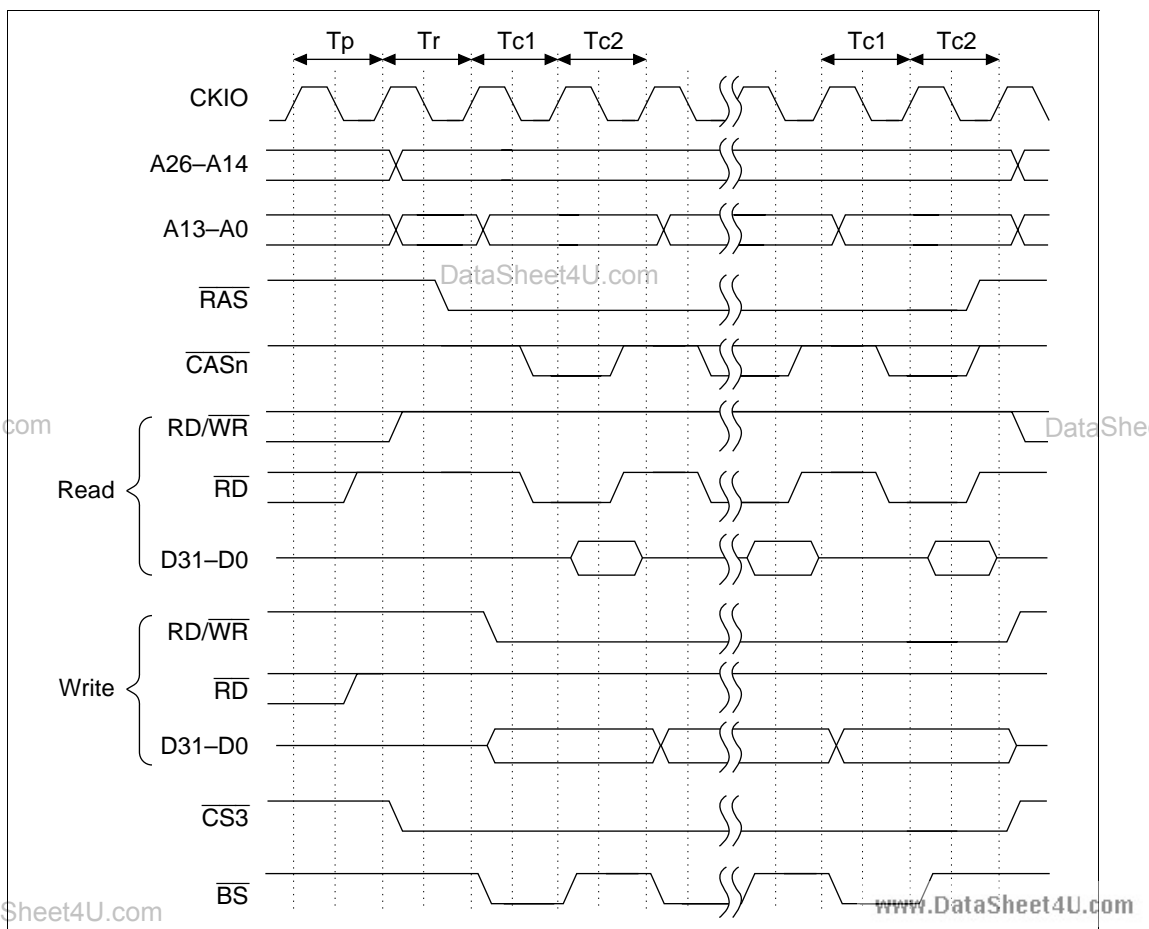

Figure 7.34 Burst Access Timing

The BSC has a function for controlling DRAM refreshes. By setting the MCR's RMODE bit to 0 and RFSH bit to 1, distributed refreshing using the CAS-before-RAS refresh cycle can be performed.

Refreshes are performed at the interval determined by the input clock selected with CKS2–CKS0 in RTCSR and the value set in RTCOR. Set the values of RTCOR and CKS2–CKS0 so they satisfy the refresh interval specifications of the DRAM being used. First, set RTCOR, RTCNT and the RMODE and RFSH bits in MCR, then set the CKS2–CKS0 bits. When a clock is selected with the CKS2–CKS0 bits, RTCNT starts counting up from the value at that time. The RTCNT value is constantly compared to the RTCOR value and a request for a refresh is made when the two match, starting a CAS-before-RAS refresh. RTCNT is cleared to 0 at that time and the count up starts again. Figure 7.35 shows the timing for the CAS-before-RAS refresh cycle.

The number of RAS assert cycles in the refresh cycle is specified by the TRAS bit in MCR. As with ordinary accesses, the specification of the RAS precharge time in refresh cycles follows the setting of the TRP bit in MCR.

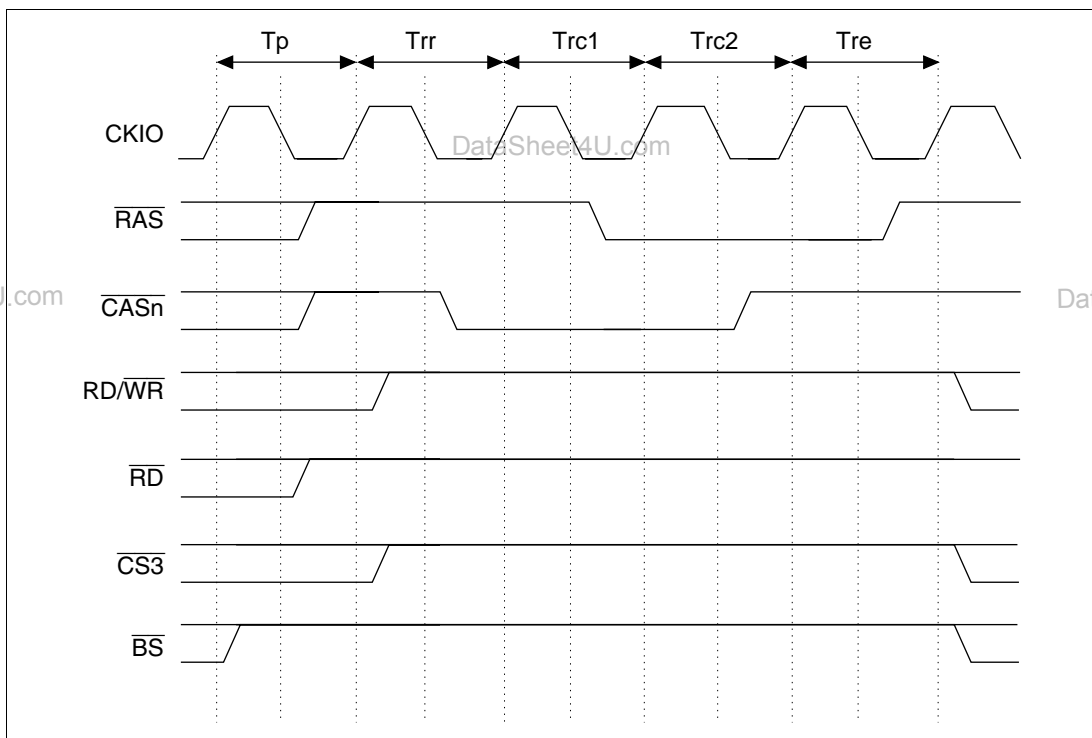

Figure 7.35 Refresh Cycle Timing

7.6.7 Power-On Sequence

When DRAM is used after the power is turned on, there is a requirement for a waiting period during which accesses cannot be performed (100 μ s or 200 μ s minimum) followed by the prescribed number of dummy CAS-before-RAS refresh cycles (usually 8). The bus state controller does not perform any special operations for the power-on reset, so the required power-on sequence must be implemented by the initialization program executed after a power-on reset.

7.7 Pseudo-SRAM Interface

7.7.1 Pseudo-SRAM Direct Connection

When the DRAM and other memory enable bits (DRAM2–DRAM0) in BCR1 are set to 011, the CS3 space becomes pseudo-SRAM space, and the pseudo-SRAM interface function can be used to directly connect the SH7604 to pseudo-SRAM. The interface data width is 16 or 32 bits.

The refresh and output enable signals of the connected pseudo-SRAM are multiplexed. The signals used for connecting pseudo-SRAM are the \overline{CE} , \overline{OE} , $\overline{WE3}$, $\overline{WE2}$, $\overline{WE1}$, and $\overline{WE0}$ signals. The $\overline{WE3}$ and $\overline{WE2}$ signals are not used when the data width is 16 bits. When non-multiplexed pseudo-SRAM is connected, the \overline{RD} signal is also used.

In addition to ordinary read and write access, burst access using the static column access function is also supported. Figure 7.36 shows an example of connections to 1-M pseudo-SRAM with separate \overline{OE} and \overline{RFSH} pins; figure 7.37 shows an example of connections to 4-M pseudo-SRAM with multiplexed $\overline{OE}/\overline{RFSH}$ pins. 256-k pseudo-SRAM is multiplexed in the same way as 4-M pseudo-SRAM. All data widths are 32 bits.

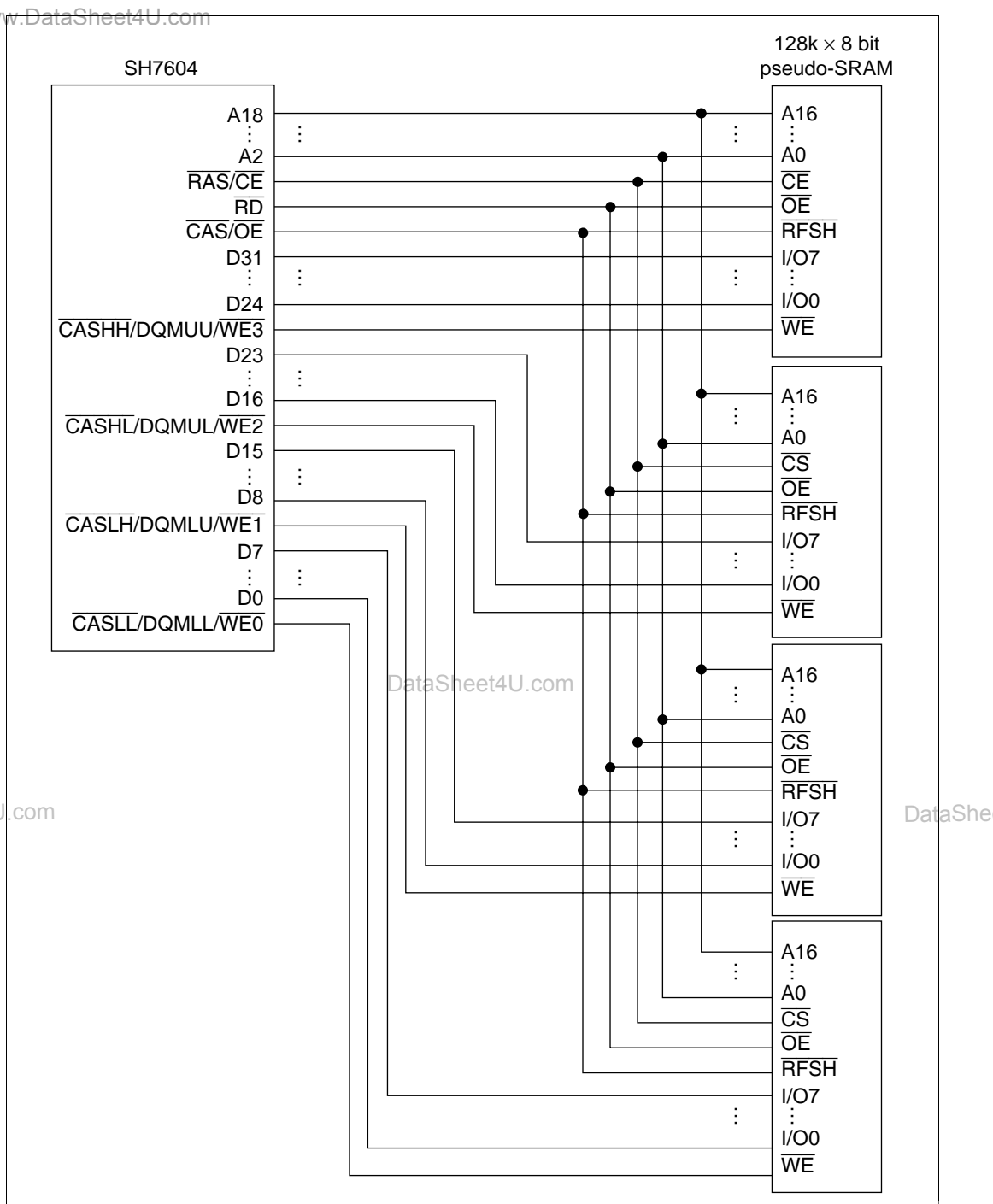

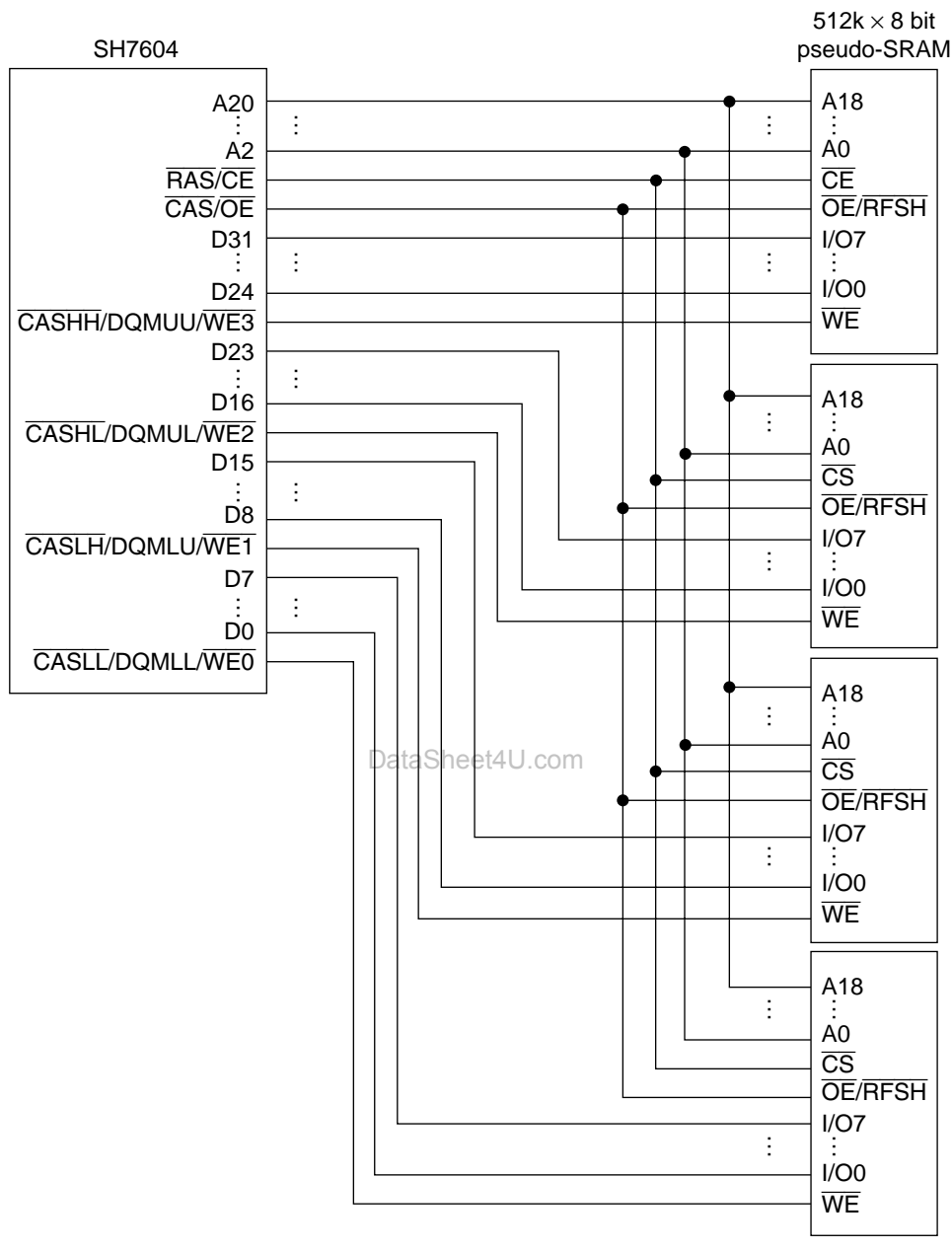

Figure 7.37 Example of Pseudo-SRAM Connection (4-Mbit Pseudo-SRAM)

Figure 7.38 shows the basic pseudo-SRAM access timing. T_p is the precharge cycle, T_r is the \overline{CE} assert cycle, T_{c1} is the write data output and \overline{BS} assert cycle, and T_{c2} is the read data fetch cycle. When accesses are consecutive, precharge cycle T_p overlaps the T_{c2} cycle of the previous access, so reads or writes can be performed in a minimum of 3 cycles each.

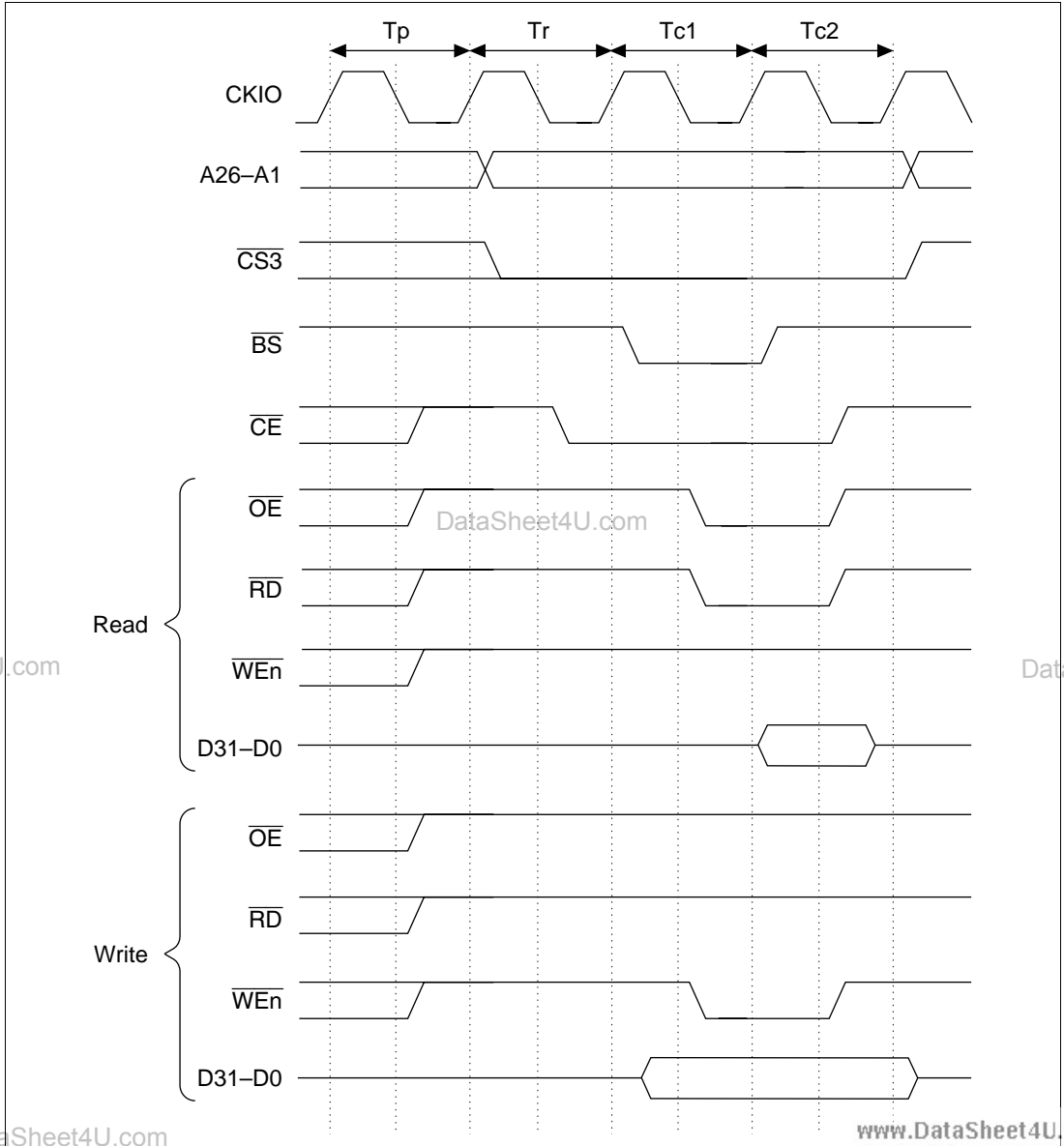

Figure 7.38 Basic Access Timing

When the clock frequency is raised, 1 cycle may not always be sufficient for all states to end, as in basic access. Setting bits in WCR and MCR enables the state to be lengthened. Figure 7.39 shows an example of lengthening a state using settings. The T_p cycle that ensures a sufficient \overline{CE} precharge time can be extended to 2 cycles by insertion of a T_{pw} cycle by means of the TRP bit in MCR. The number of cycles between \overline{BS} assert and the end of access can be extended from 2 to 4 cycles by setting the W31/W30 bits in WCR. When a value other than 00 is set in W31 and W30, the external wait pin \overline{WAIT} is also sampled, so the number of cycles can be further increased. Figure 7.40 shows the timing of wait state control using the \overline{WAIT} pin. In either case, when consecutive accesses occur, the T_p cycle of one access overlaps the T_{c2} cycle of the previous access. The RCD bit in MCR is set to 0 for a pseudo-SRAM interface, but when set to 1, the number of cycles from the \overline{CE} assert to the \overline{BS} assert or write data output becomes 2.

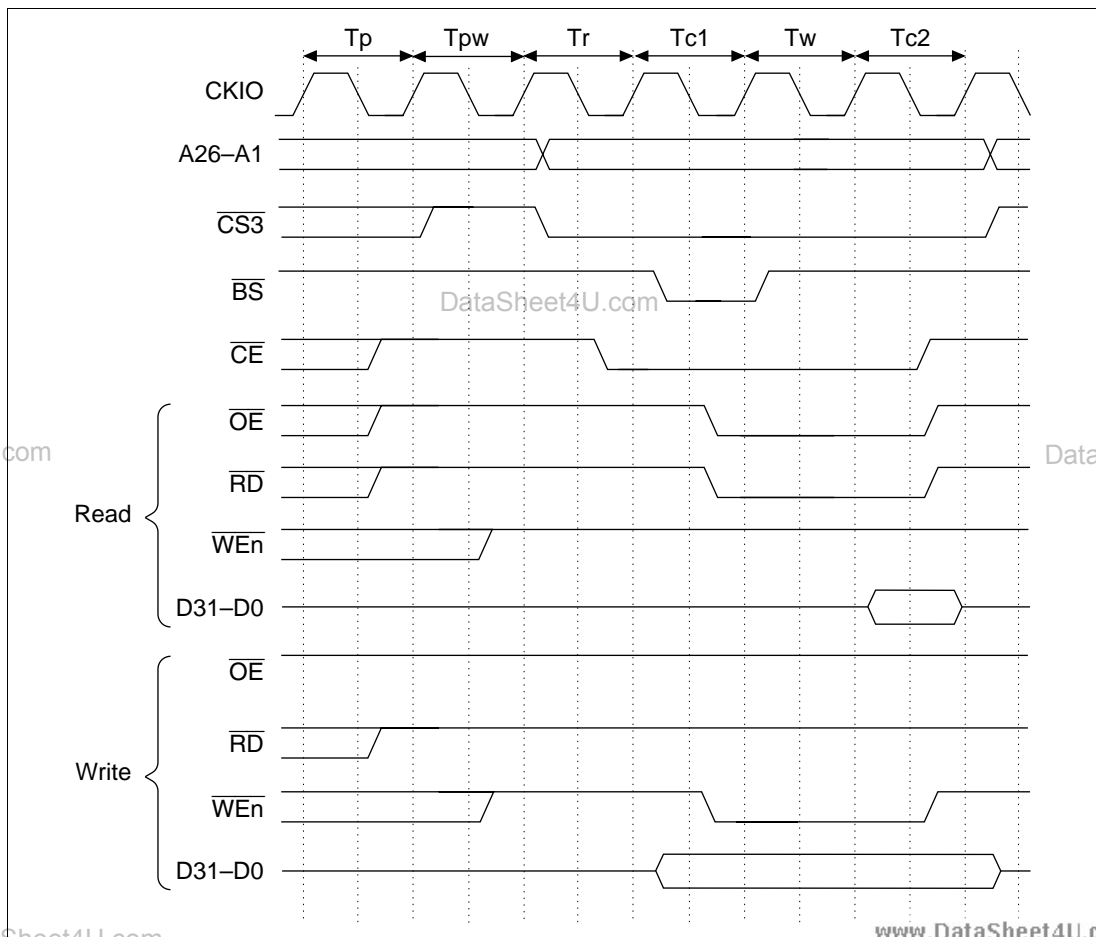

Figure 7.39 Wait State Timing

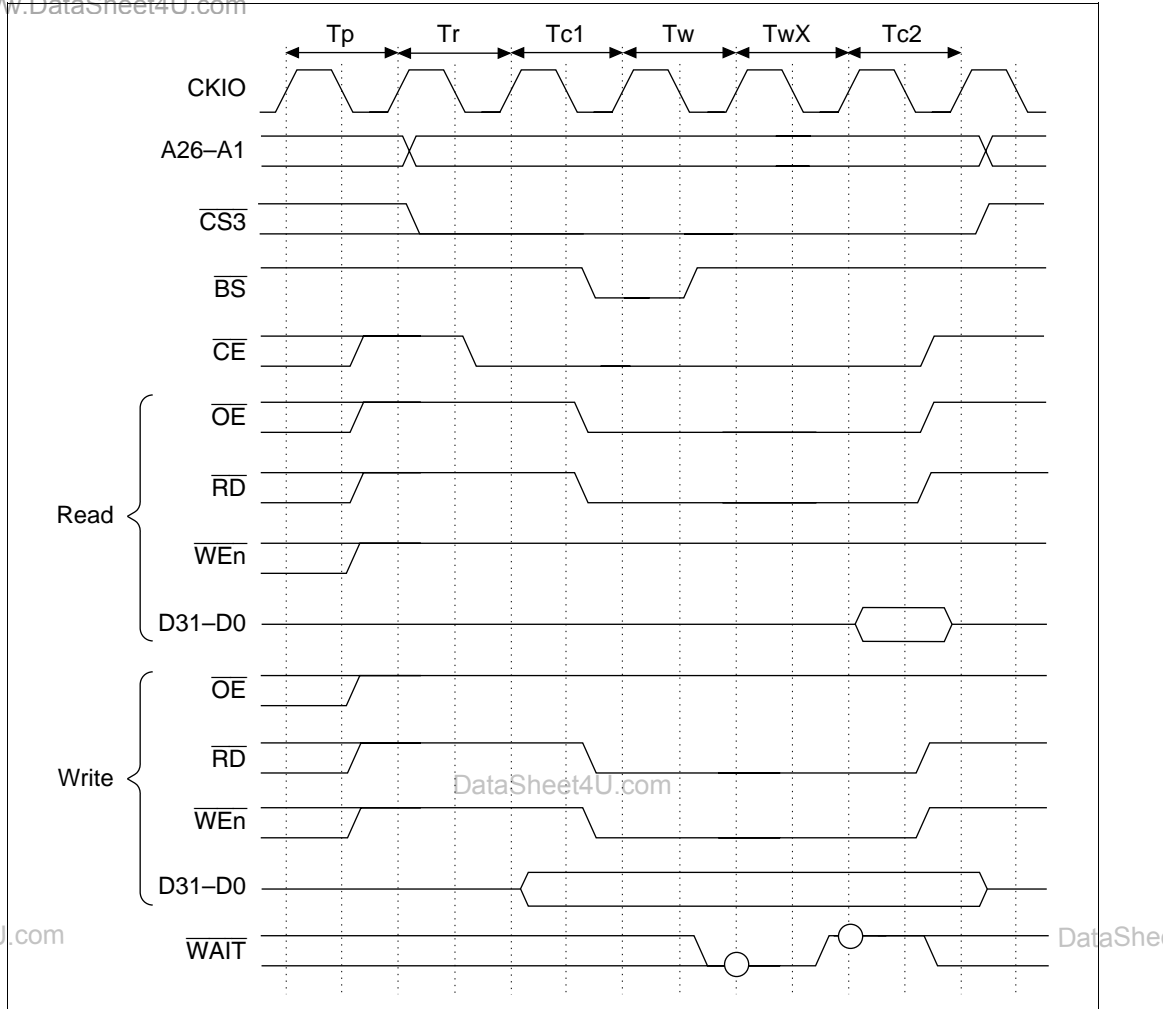

Figure 7.40 External Wait State Timing

7.7.4 Burst Access

In addition to normal access, in which CE is alternatively asserted and negated at every access, when consecutive accesses are to the same row address the pseudo-SRAM can access data at high speed by changing only the column address and leaving CE asserted. This function is called the static column mode. Select between ordinary access and burst mode using static column mode by setting the burst enable bit (BE) in MCR. Figure 7.41 shows the timing of burst operation using static column mode. When performing burst access, cycles can be inserted using the wait state control function.

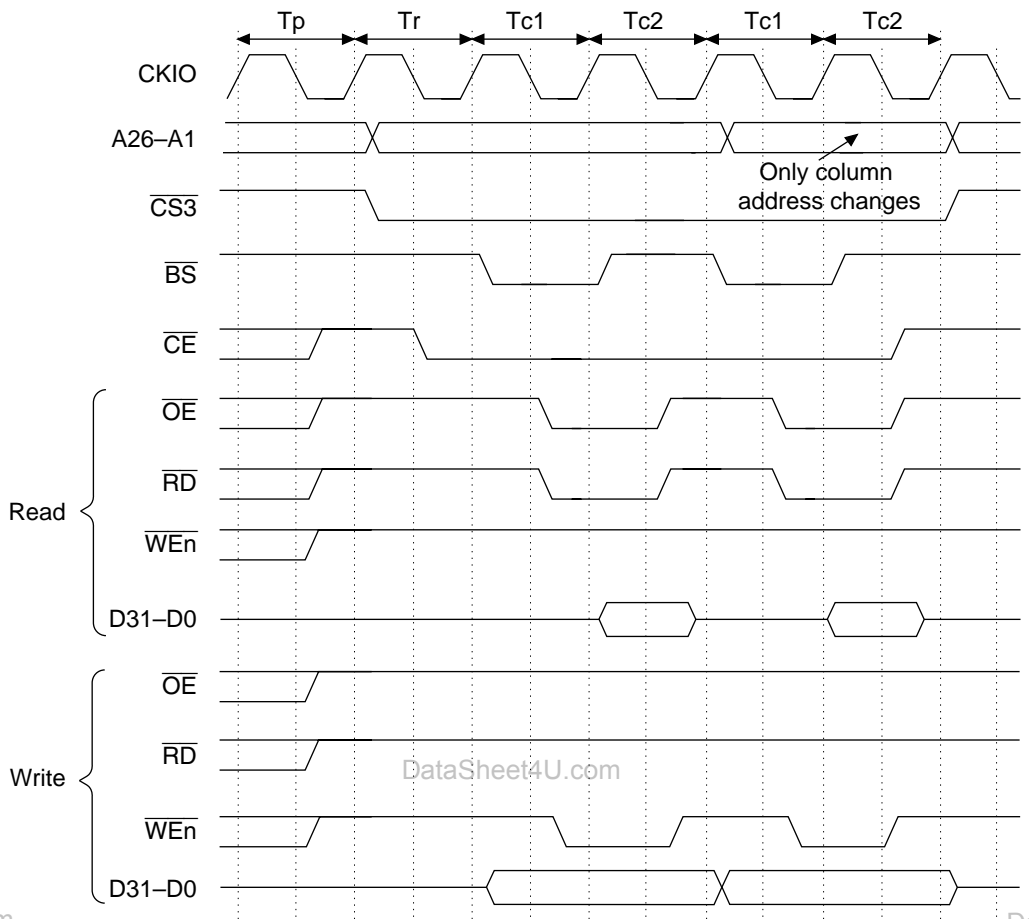

Figure 7.41 Static Column Mode

7.7.5 Refreshing

The BSC has a function for controlling pseudo-SRAM refreshing. By setting the MCR's RMODE bit to 0 and RFSH bit to 1, distributed refreshing using the auto-refresh cycle can be performed.

Refreshes are performed at the interval determined by the input clock selected with CKS2-CKS0 in RTCSR and the value set in RTCOR. Set the values of RTCOR and CKS2-CKS0 so they satisfy the refresh interval specifications of the pseudo-SRAM being used. First, set RTCOR, RTCNT and the RMODE and RFSH bits in MCR, then set the CKS2-CKS0 bits. When a clock is selected with the CKS2-CKS0 bits, RTCNT starts counting up from the value at that time. The RTCNT value is constantly compared to the RTCOR value and a request for a refresh is made when the two match, starting an auto-refresh. RTCNT is cleared to 0 at that time and the count up starts again. Figure 7.42 shows the timing for the auto-refresh cycle.

The number of \overline{OE} assert cycles for auto-refresh is specified by the \overline{TRAS} bit in MCR. As with ordinary accesses, the specification of the precharge time from \overline{OE} negation to the next \overline{CE} assert follows the setting of the TRP bit in MCR.

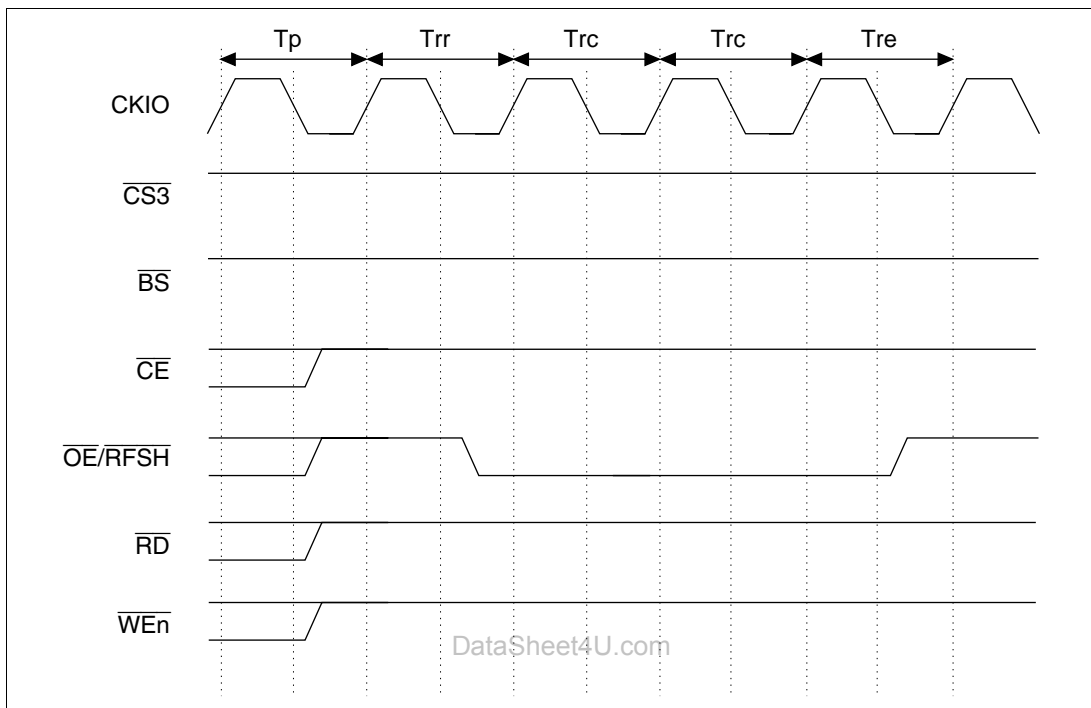

Figure 7.42 Auto-Refresh

The self-refresh mode is initiated in the pseudo-SRAM when the \overline{RFSH} signal stays low for a prescribed period of time. A self-refresh is started by setting the RMODE and RFSH bits to 1. During the self-refresh, the pseudo-SRAM cannot be accessed. To clear self-refreshing, set either the RMODE or RFSH bit to 0. After self-refresh mode is cleared, issuing of commands is inhibited for 1 auto-refresh cycle. If more time than this is required to return from self-refresh, write the program so that there are no accesses to the pseudo-SRAM, including auto-refreshes, during this period. Figure 7.43 shows the self-refresh timing. After self-refreshing is cleared, immediately set the pseudo-SRAM so that auto-refresh is performed in the correct interval. This ensures correct self-refresh clearing and data retention. When time is required between clearing the self-refreshing and initiating the auto-refresh mode, this time must be reflected in the initial RTCNT setting.

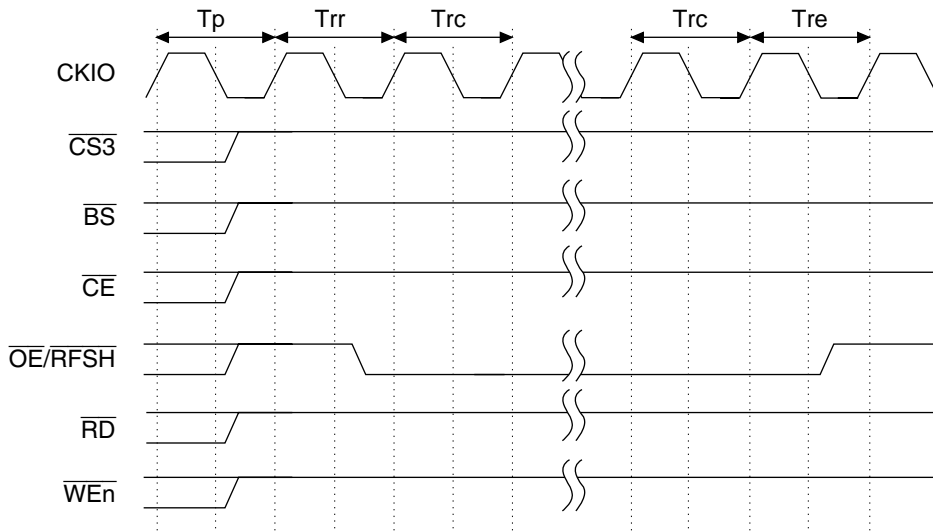

Figure 7.43 Self-Refresh

7.7.6 Power-On Sequence

When pseudo-SRAM is used after the power is turned on, there is a requirement for a waiting period during which accesses cannot be performed (100 μ s minimum) followed by the prescribed number of dummy auto-refresh cycles (usually 8). The bus state controller does not perform any special operations for the power-on reset, so the required power-on sequence must be implemented by the initialization program executed after a power-on reset.

7.8 Burst ROM Interface

Set the BSTROM bit in BCR1 to set the CS0 space for connection to burst ROM. The burst ROM interface is used to permit fast access to ROMs that have the nibble access function. Figure 7.44 shows the timing of nibble accesses to burst ROM. Set for two wait cycles. The access is basically the same as an ordinary access, but when the first cycle ends, only the address is changed. The CS0 signal is not negated, enabling the next access to be conducted without the T1 cycle required for ordinary space access. From the second time on, the T1 cycle is omitted, so access is 1 cycle faster than ordinary accesses. Currently, the nibble access can only be used on 4-address ROM. This function can only be utilized for word or longword reads to 8-bit ROM and longword reads to 16-bit ROM. Mask ROMs have slow access speeds and require 4 instruction fetches for 8-bit widths and 16 accesses for cache fills. Limited support of nibble access was thus added to alleviate this problem. When connecting to an 8-bit width ROM, a maximum of 4 consecutive accesses are performed; when connecting to a 16-bit width ROM, a maximum of 2 consecutive accesses are performed. Figure 7.45 shows the relationship between data width and access size. For cache fills and DMAC 16-byte transfers, longword accesses are repeated 4 times.

When one or more wait states are set for a burst ROM access, the $\overline{\text{WAIT}}$ pin is sampled. When the burst ROM is set and 0 specified for waits, there are 2 access cycles from the second time on. Figure 7.46 shows the timing.

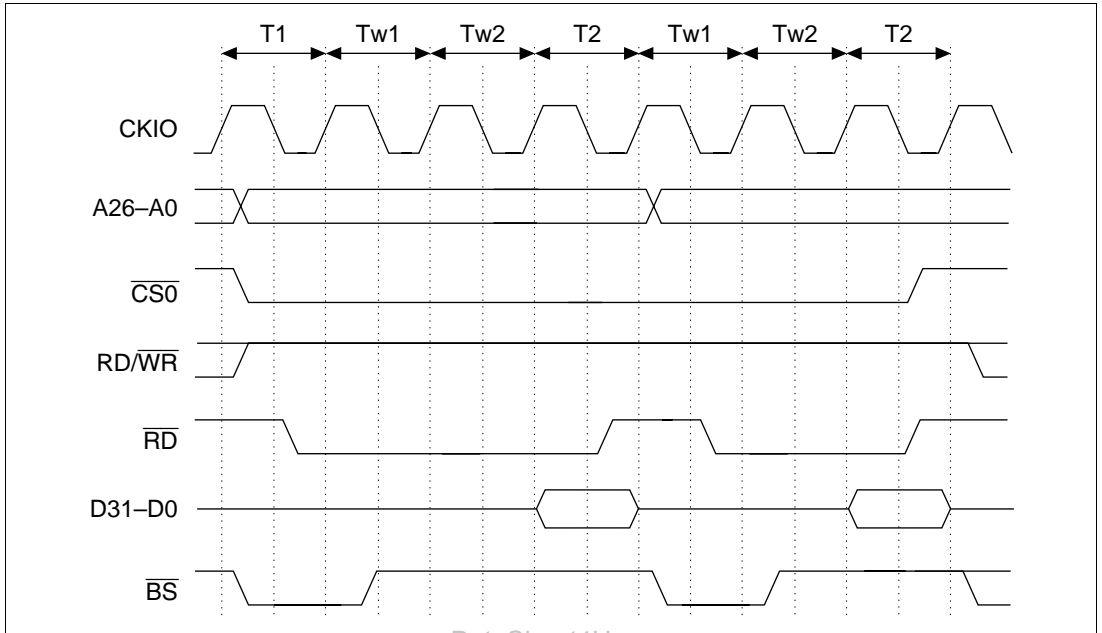

Figure 7.44 Burst ROM Nibble Access (2 Wait States)

T1	Tw	T2	Tw	T2	Tw	T2	Tw	T2
----	----	----	----	----	----	----	----	----

8-bit bus-width longword access

T1	Tw	T2	Tw	T2
----	----	----	----	----

8-bit bus-width access

T1	Tw	T2
----	----	----

8-bit bus-width byte access

T1	Tw	T2	Tw	T2
----	----	----	----	----

16-bit bus-width longword access

T1	Tw	T2
----	----	----

16-bit bus-width word access

T1	Tw	T2
----	----	----

16-bit bus-width byte access

T1	Tw	T2
----	----	----

32-bit bus-width longword access

T1	Tw	T2
----	----	----

32-bit bus-width word access

T1	Tw	T2
----	----	----

32-bit bus-width byte access [DataSheet4U.com](http://www.DataSheet4U.com)

Figure 7.45 Data Width and Burst ROM Access (1 Wait State)

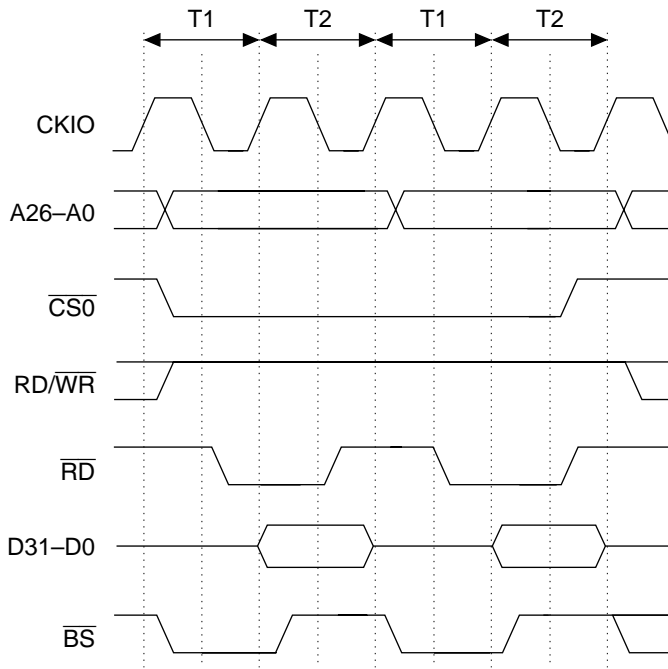

Figure 7.46 Burst ROM Nibble Access (No Wait States)

7.9 Waits between Access Cycles

Because operating frequencies have become high, when a read from a slow device is completed, data buffers may not go off in time to prevent data conflicts with the next access. This lowers device reliability and causes errors. To prevent this, a function has been added to avoid data conflicts that memorizes the space and read/write state of the preceding access and inserts a wait in the access cycle for those cases in which problems are found to occur when the next access starts up. Checks are performed in two cases: if a read cycle is followed immediately by a read access to a different CS space, and if a read access is followed immediately by a write from the SH7604. When the SH7604 is writing continuously, if the format is always to have the direction of the data from the SH7604 to other memory, there are no particular problems. Neither is there any particular problem if the following read access is to the same CS space, since data is output from the same data buffer. The number of idle cycles to be inserted into the access cycle when reading from another CS space, or performing a write, after a read from the CS3 space, is specified by the IW31 and IW30 bits in WCR. Likewise, IW21 and IW20 specify the number of idle cycles after CS2 reads, IW11 and IW10 specify the number after CS1 reads, and IW01 and IW00 specify the number after CS0 reads. From 0 to 2 cycles can be specified. When there is already a gap between accesses, the number of empty cycles is subtracted from the number of idle cycles before insertion. When a write cycle is performed immediately after a read access, 1 wait cycle is inserted even when 0 is specified for waits between access cycles.

When the SH7604 shifts to a read cycle immediately after a write, the write data becomes high impedance when the clock rises, but the \overline{RD} signal, which indicates read cycle data output enable, is not asserted until the clock falls. The result is that no waits are inserted into the access cycle.

When bus arbitration is being performed, an empty cycle is inserted for arbitration, so no wait is inserted between cycles.

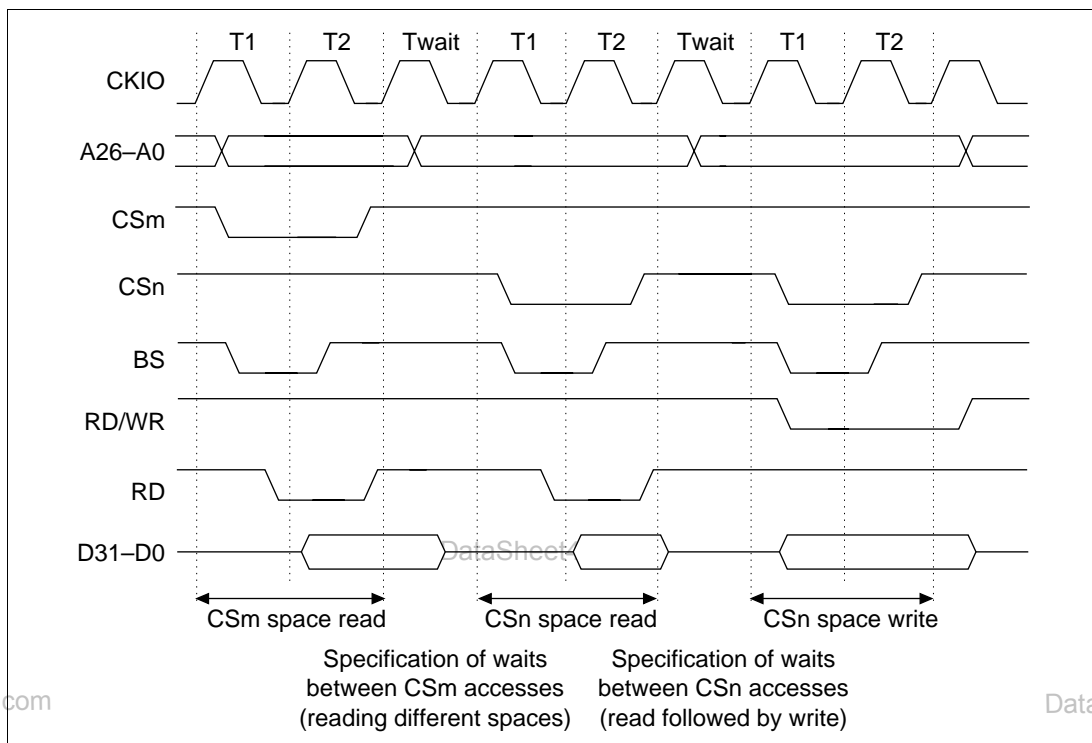

Figure 7.47 Waits between Access Cycles

7.10 Bus Arbitration

The SH7604 has a bus arbitration function that, when a bus release request is received from an external device, releases the bus to that device after the bus cycle being executed is completed. In addition, it also has a bus arbitration function for supporting the connection of two processors. These are connected to each other as master and slave through bus arbitration, which enables a multiprocessor system to be implemented with a minimum of hardware.

There are three modes for bus arbitration: master mode, partial-share master mode, and slave mode. Master mode keeps the bus under normal conditions and permits other devices to use the bus by releasing it when they request its use. The slave mode normally does not have the bus. The bus is requested when an external bus access cycle comes up and then releases the bus when the

access is completed. The partial-share master mode only shares CS2 space with external devices. For the CS2 space, the mode is slave mode; for other spaces, the bus is held constantly without any bus arbitration. Which CS space of the chip in master mode the CS2 space of the chip in partial-share master mode is allocated to, is determined by external circuitry.

Master or slave mode can be specified using external mode pins. Partial-share master mode is reached from master mode by a software setting. See Section 3, Oscillator Circuits and Operating Modes, for the external mode pin settings. When a device in master or slave mode does not have the bus, the bus goes to high impedance, so the master mode chip and slave mode chips can be connected directly. In the partial-share master mode, the bus is always driven, so an external buffer is needed to connect to a master bus. In master mode, a connection to an external device requesting the bus can be substituted for the slave mode connection. In the following explanation, external devices requesting the bus are also called slaves.

The SH7604 has two internal bus masters, the CPU and the DMAC. When synchronous DRAM, DRAM or pseudo-SRAM is connected and refresh control is performed, the refresh request becomes a third master. In addition to these, there are also bus requests from external devices while in the master mode. The priority for bus requests when they occur simultaneously is, highest to lowest, refresh requests, bus requests from external devices, DMAC and CPU.

When the bus is being passed between slave and master, all bus control signals are negated before the bus is released to prevent erroneous operation of the connected devices. Once the bus is received, the bus control signals change from negated to bus driven. The master and slave passing the bus between them drive the same signal values, so output buffer conflict is avoided. Turning the output buffer off for the bus control signals on the side that releases the bus and on at the side acquiring the bus can eliminate the high impedance period of the signals. It is usually not necessary to insert a pull-up resistance into these control signals to prevent malfunction caused by external noise while they are at high impedance.

Bus permission is granted at the end of the bus cycle. When the bus is requested, the bus is released immediately if there is no ongoing bus cycle. If there is a current bus cycle, the bus is not released until the bus cycle ends. Even when there does not appear to be an ongoing bus cycle when seen from outside the SH7604, it cannot be determined whether or not the bus will be released immediately when a bus control signal such as a \overline{CS}_n signal is seen, since an internal bus cycle, such as inserting a wait between access cycles, may have been started. The bus cannot be released during burst transfers for cache fills or 16-byte DMAC block transfers. Likewise, the bus cannot be released between the read and write cycles of a TAS instruction. Arbitration is also not performed between multiple bus cycles produced by a data width smaller than the access size, such as a longword access to an 8-bit data width memory. Bus arbitration is performed between external vector fetch, PC save, and SR save cycles during interrupt handling, which are all independent accesses.

Because the CPU in the SH7604 is connected to cache memory by a dedicated internal bus, cache memory can be read even when the bus is being used by another bus master on the chip or

externally. Writing from the CPU always produces a write cycle externally since the write-through system is used by the SH7604 for the cache. When an external bus address monitor is not specified by the user break controller, the internal bus that connects the CPU, DMAC and on-chip peripheral modules can operate in parallel to the external bus. This means that both read and write accesses from CPU to on-chip peripheral modules and from DMAC to on-chip peripheral module are possible. If an external bus address monitor is specified, the internal bus will be used for address monitoring when the bus is passed to the external bus master, so accesses to on-chip peripheral modules by the CPU and DMAC must wait for the bus to be returned.

7.10.1 Master Mode

Master mode processors keep the bus unless they receive a bus request. When a bus release request ($\overline{\text{BRLS}}$) assertion (low level) is received from an external device, buses are released and a bus grant ($\overline{\text{BGR}}$) is asserted (low level) as soon as the bus cycle being executed is completed. When it receives a negated (high level) $\overline{\text{BRLS}}$ signal, indicating that the slave has released the bus, it negates the $\overline{\text{BGR}}$ (to high level) and begins using the bus. When the bus is released, all output and I/O signals related to the bus interface are changed to high impedance, except for the CKE signal for the synchronous DRAM interface, the $\overline{\text{BGR}}$ signal for bus arbitration, and DMA transfer control signals DACK0 and DACK1.

When the DRAM or pseudo-SRAM has finished precharging, the bus is released. The synchronous DRAM also issues a precharge command to the active bank or banks. After this is completed, the bus is released. DataSheet4U.com

The specific bus release sequence is as follows. First, the bus use enable signal is asserted synchronously with the fall of the clock. Half a cycle later, the address bus and data bus become high impedance synchronous with the rise of the clock. Thereafter the bus control signals ($\overline{\text{BS}}$, $\overline{\text{CSn}}$, $\overline{\text{RAS}}$, $\overline{\text{CAS}}$, $\overline{\text{WEn}}$, $\overline{\text{RD}}$, $\overline{\text{RD/WR}}$, $\overline{\text{IVECF}}$) become high impedance with the fall of the clock. All of these signals are negated at least 1.5 cycles before they become high impedance. Sampling for bus request signals occurs at the clock fall. DataSheet4U.com

The sequence when the bus is taken back from the slave is as follows. When the negation of $\overline{\text{BRLS}}$ is detected at a clock fall, $\overline{\text{BGR}}$ is immediately negated and the master simultaneously starts to drive the bus control signals. The address bus and data bus are driven starting at the next clock rise. The bus control signals are asserted and the bus cycle actually starts from the same clock rise at which the address and data signals are driven, at the earliest. Figure 7.48 shows the timing of bus arbitration in master mode.

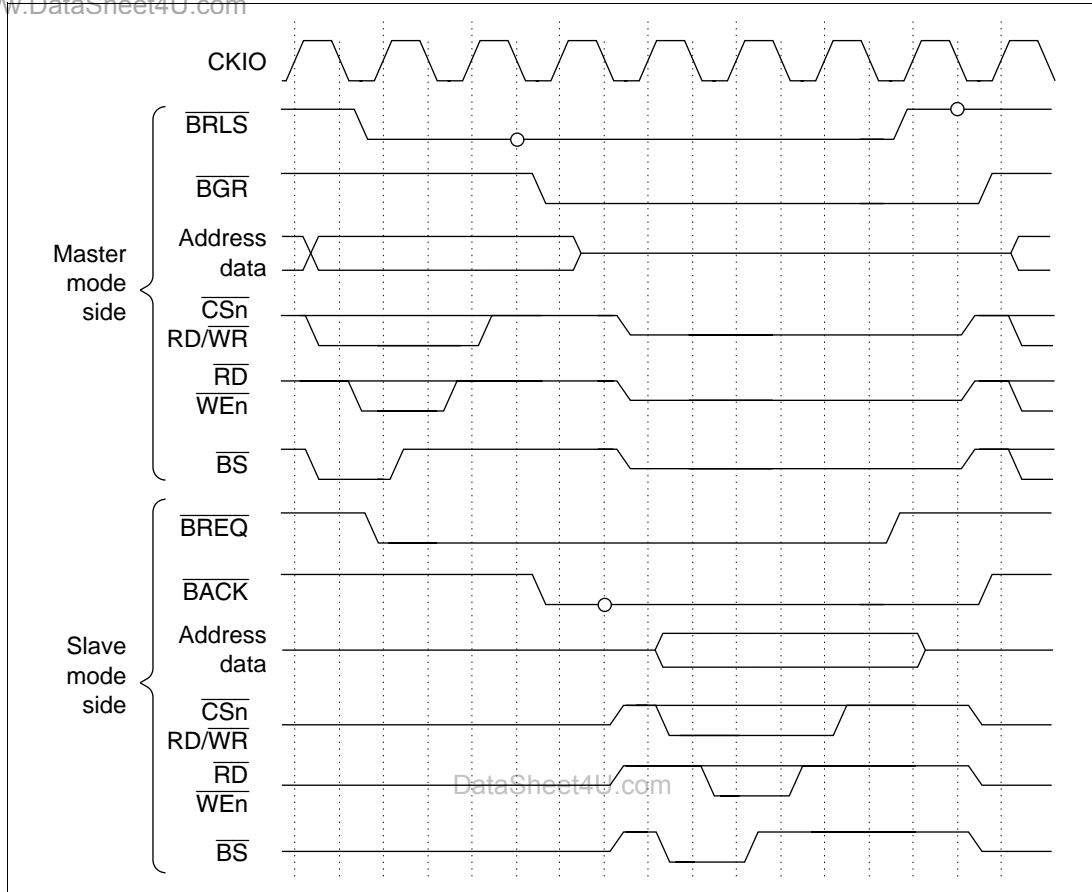

Figure 7.48 Bus Arbitration

When a refresh request is generated in the SH7604 while $\overline{\text{BGR}}$ is asserted and the bus released, the $\overline{\text{BGR}}$ may or may not be negated.

Case in Which $\overline{\text{BGR}}$ is Negated: If access processing for an external device has not been started before the refresh request is generated, the $\overline{\text{BGR}}$ signal will be negated even while the $\overline{\text{BRLS}}$ signal is asserted. Even though the $\overline{\text{BGR}}$ signal is negated, a refresh operation will not begin unless the $\overline{\text{BRLS}}$ signal is negated. Refreshing begins as soon as $\overline{\text{BRLS}}$ is negated.

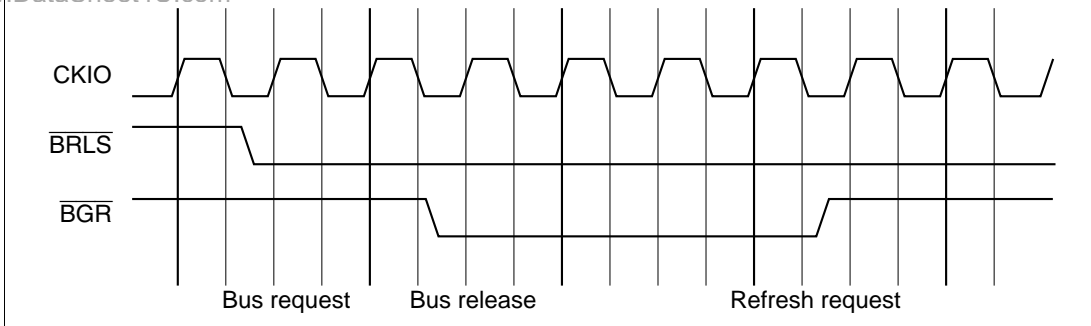

Figure 7.49 Case in Which $\overline{\text{BGR}}$ is Negated

Case in Which $\overline{\text{BGR}}$ is Not Negated: If access processing for an external device has been initiated before the refresh request is generated, and the device is waiting to acquire the bus, the $\overline{\text{BGR}}$ signal will not be negated. After the $\overline{\text{BRLS}}$ signal is negated, refreshing begins after completion of the access involving the external device that was waiting for the bus.

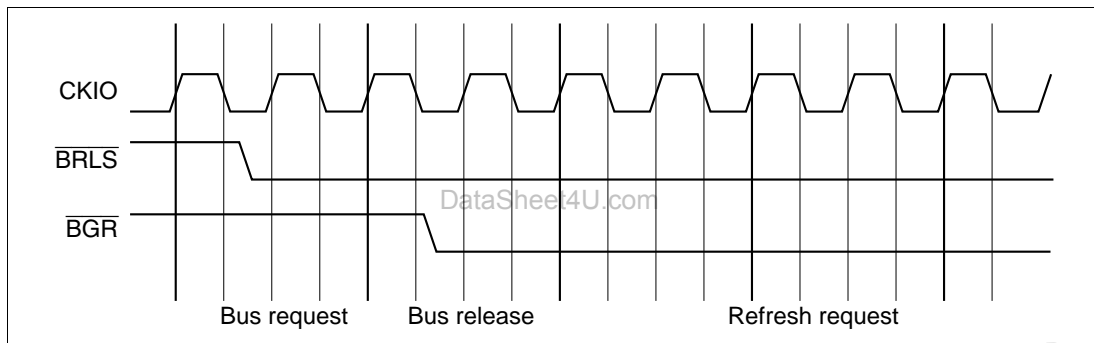

Figure 7.50 Case in Which $\overline{\text{BGR}}$ is Not Negated

When the SH7604 is being used in slave mode, the bus is released as soon as the bus access cycle ends, but in the case of a slave designed by the user, multiple consecutive bus accesses may be attempted in order to reduce the arbitration overhead. To ensure dependable refreshing in this case, the design should provide for the bus to be released to prevent the slave holding the bus for longer than the refresh cycle.

7.10.2 Slave Mode

In slave mode, the bus is usually released. External devices cannot be accessed unless the bus arbitration sequence is performed to capture the bus. During a reset, the bus is released and the bus arbitration sequence starts from the reset vector fetch.

The $\overline{\text{BREQ}}$ signal is asserted (to low level) synchronously with the clock fall for capturing the bus. The assertion of the $\overline{\text{BACK}}$ signal (to low level) is sampled at the clock fall. When a $\overline{\text{BACK}}$

assertion is detected, the bus control signals are immediately driven at the negate level. Thereafter the address and data bus drivers turn on at the following clock rise and the bus cycle starts. The last signal negated when the access cycle ended is synchronized with the clock rise. Half a cycle after the clock rise, the $\overline{\text{BREQ}}$ signal is negated, the master notified that the bus is released, and one cycle later the address and data output buffers turned off (high impedance). At the following clock fall, the control signals become high impedance. Figure 7.48 shows the bus arbitration timing for slave mode.

When the slave access cycle is for DRAM, synchronous DRAM or pseudo-SRAM, the bus is released when the memory precharge finishes, just as for master mode. Since refresh control is handled by the master mode device, any refresh control setting performed in the slave mode is ignored. Figure 7.51 shows an example of master mode and slave mode connections.

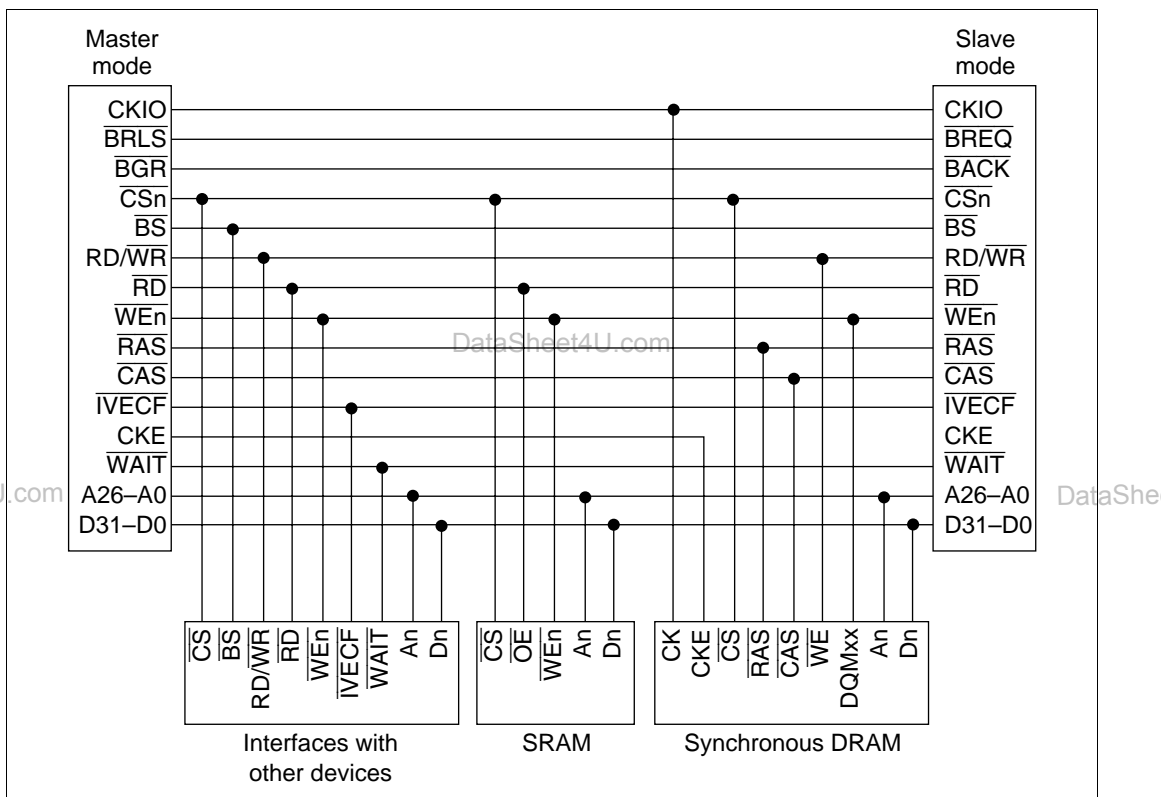

Figure 7.51 Connection between Master and Slave Devices

7.10.3 Partial-Share Master Mode

In partial-share master mode, only the CS2 space is shared with other devices. Other CS spaces can always be accessed. To set partial-share master mode, set to master mode using the external mode pins and then set the PSHR bit in BCR to 1 in the power-on reset initialization procedure.

During a manual reset, the values of the bus state controller setting registers are held, so they do not need to be set again.

Partial-share master mode is designed to be used with a chip in master mode. Figure 7.52 shows an example of connections between a partial-share master mode and master mode SH7604. On the master mode side, the CS3 space is connected to synchronous DRAM and the CS0 space to ROM. On the partial-share master mode side, the CS0 space is connected to ROM, the master side synchronous DRAM is connected to the CS2 space, and the CS3 space is connected to dedicated synchronous DRAM. The partial-share master is also connected through the CS2 space to the master synchronous DRAM so it can be accessed. The master, however, cannot access devices on the partial-share master side. There is a buffer for addresses and control signals and a buffer for data located between the partial-share master and the master. They are controlled by a buffer control circuit. The buffers latch signals synchronous to the clock rise and match timing, so an AC operating margin is assured. When the master side synchronous DRAM is read from the partial-share master, however, address and control line output requires an extra cycle, and input of read data requires an extra cycle. The CAS latency setting within the bus controller should be 2 higher than the actual synchronous DRAM CAS latency. If the clock cycle is sufficiently long relative to the time for addresses, control signals and write signals from the partial-share master to reach the synchronous DRAM on the master side through the buffer and to the time for read data from the synchronous DRAM on the master side to reach the partial-share master through the buffer, if the respective setup time limits can be satisfied, then there is no need to delay by one cycle clock signal synchronously with the clock. In this case, the previously described latch is not needed.

DataSheet4U.com

When a processor in the partial-share master mode accesses the CS2 space, it performs the following procedure. The $\overline{\text{BREQ}}$ signal is asserted at the clock fall to request the bus from the master. The $\overline{\text{BACK}}$ signal is sampled at every clock fall, and when an assertion is received, the access cycle starts at the next clock rise. After the access ends, $\overline{\text{BREQ}}$ is negated at the clock fall. Control of the buffer when a CS2 space device is being accessed from the partial-share master references the $\overline{\text{BREQ}}$ and $\overline{\text{BACK}}$ signals. Notification that the bus is enabled for use is conducted by the $\overline{\text{BACK}}$ connected to the partial-share master, but the $\overline{\text{BACK}}$ signal may be negated while the bus is in use when the master requires the bus back to service a refresh or the like. For this reason, the $\overline{\text{BREQ}}$ signal must be monitored to see whether the partial-share master can continue using the bus after $\overline{\text{BACK}}$ is asserted. For address buffers, after the address buffer is turned on by the detection of a $\overline{\text{BACK}}$ assertion, the buffer remains on until $\overline{\text{BREQ}}$ is negated. When $\overline{\text{BREQ}}$ is negated, the buffer goes off. When the buffer is slow going off and it conflicts with the start of the access cycle at the master, the $\overline{\text{BREQ}}$ signal output from the partial-share master as part of the buffer control circuit must be delayed a clock and input to the $\overline{\text{BRLS}}$ signal.

When the bus is released after the CS2 space is accessed in partial-share master mode, the bus will be released after waiting for the time required for auto-precharge if the CS2 space was synchronous DRAM. Other spaces always have the bus themselves, so there is no precharge of CS3 space memory upon release after a CS2 space bus request, even when DRAM, synchronous DRAM or pseudo-SRAM is connected to the CS3 space. Partial-share master mode does not refresh CS2 (it is ignored).

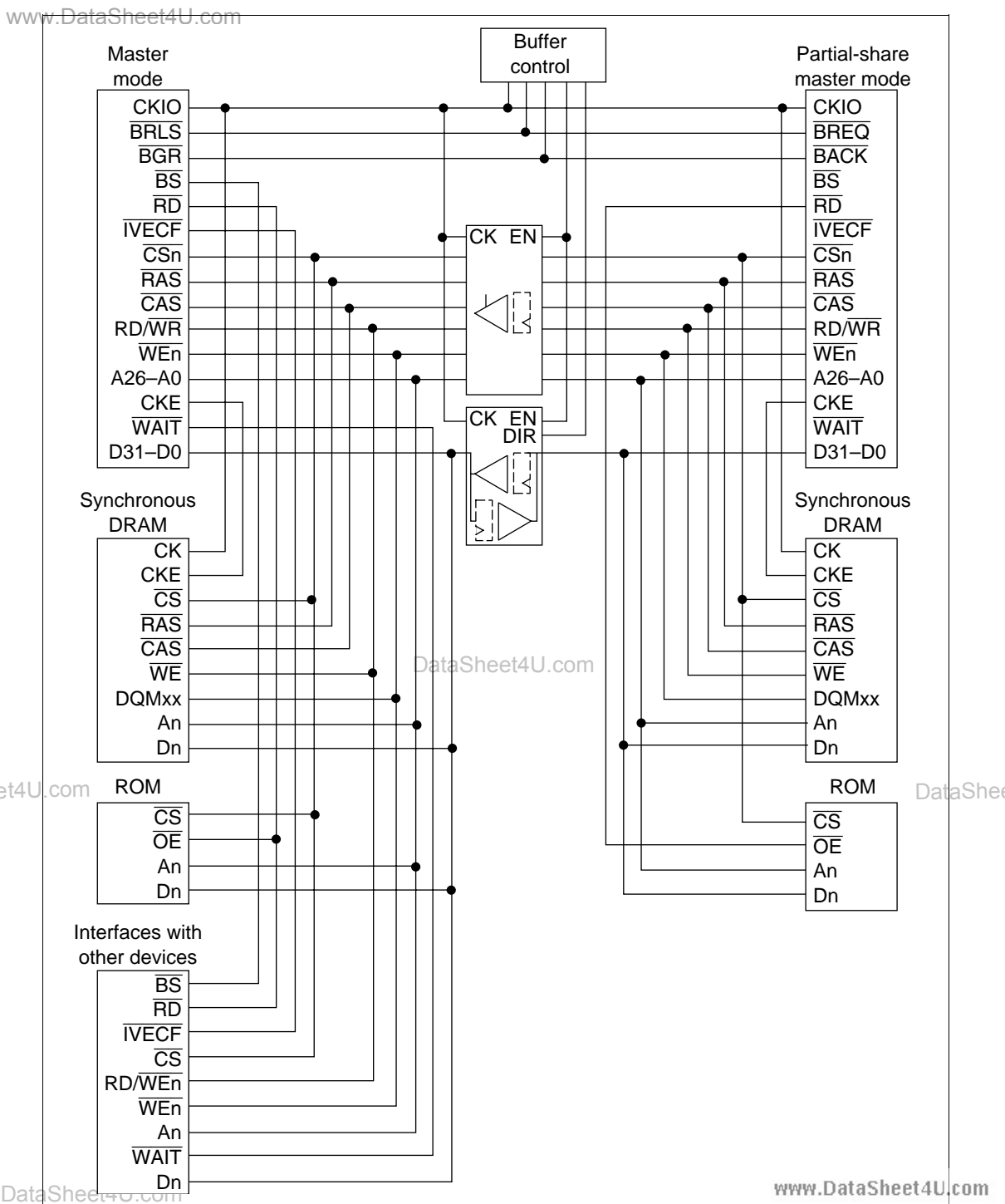

Figure 7.52 Connection between Master and Partial-Share Master Devices

7.10.4 External Bus Address Monitor

The master and slave modes have a function to generate break interrupts and monitor the external bus access cycle using the user break controller. The bus cycle is monitored by sampling the external bus every time the clock rises while the bus is released. If the \overline{BS} signal is found to be asserted (low level) when sampling is performed, the address at that time (A26–A0) and read/write signal RD/\overline{WR} are fetched and compared as the access address and access type (read or write).

When an external device has captured the bus and the DRAM or synchronous DRAM is in an access cycle, the following points are important to make the address monitor function correctly. \overline{BS} goes low in the DRAM or synchronous DRAM access cycle in synchronization with the cycle that outputs the column address. Because only the address of the cycle in which the \overline{BS} signal is low is fetched and compared, even access to memories like these that multiplex addresses requires outputting of the row address in the upper address bits. One of the bits of the address signal in the column address output cycle in synchronous DRAM is used to specify the bank address, while the other bit is used to specify whether to perform an auto-precharge. These always cause breaks on the compared address, so mask these two bits when setting the comparison address. The masked bit position is described in the section 7.5.2, Address Multiplexing.

7.10.5 Master/Slave Coordination

Roles must be shared between the master and slave to control system resources without contradictions. DRAM, synchronous DRAM and pseudo-SRAM must be initialized before use. When using standby operation to lower power consumption, the load must also be shared.

This SH7604 was designed with the idea that the master mode device would handle all controls, such as initialization, refreshing, and standby control. When a 2-processor structure of connected master and slave is used, all processing except for direct accesses to memory is controlled by the master. When master mode is combined with partial-share master mode, the partial-share master mode processor handles initialization, refreshing, and standby control for all CS spaces connected to it except for the CS2 space. The master initializes memory connected directly to it.

The hardware or software sequence should be designed so that there are no slave-side processor accesses until memory that requires initialization before use such as DRAM, synchronous DRAM and pseudo-SRAM has completed its initialization. One method is to install an external circuit that clears slave resets from the master. Another is to have the master write a flag when initialization is complete to an SRAM or the like that does not require initialization, and then not to start access until this flag is acknowledged by the slave. A third method is to install an external circuit that can send an interrupt from master to slave and clear the slave's standby state with an interrupt from the master to the slave when initialization ends.

In standby mode or the like when synchronous DRAM and pseudo-SRAM are in self-refresh mode, memory is not precharged until the mode is cleared, so the master cannot release the bus.

The design should provide for the master to put the slave to sleep before self-refresh mode starts

or otherwise prevent the slave access cycle from starting, which prevents the slave from producing a bus release request. The slave accesses these types of memories after the master finishes any processing necessary when the self-refresh mode is cleared, such as refresh settings.

7.11 Other Topics

7.11.1 Resets

The bus state controller is completely initialized only in a power-on reset. All signals are immediately negated, regardless of where in the bus cycle the SH7604 is, and the output buffer is turned off if the bus arbitration mode is slave. Signal negation is simultaneous with turning the output buffer off. All control registers are initialized. In standby mode, sleep mode, and a manual reset, no bus state controller control registers are initialized. When a manual reset is performed, any executing bus cycles are completed, and then the SH7604 waits for an access. When a cache fill or 16-byte DMAC transfer is executing, the CPU or DMAC that is the bus master ends the access in a longword unit, since the access request is canceled by the manual reset. This means that when a manual reset is executed during a cache fill, the cache contents can no longer be guaranteed. During a manual reset, the RTCNT does not count up, so no refresh request is generated, and a refresh cycle is not initiated. To preserve the data of the DRAM, synchronous DRAM or pseudo-SRAM, the pulse width of the manual reset must be shorter than the refresh interval. Master mode chips accept arbitration requests even when a manual reset signal is asserted. When a reset is executed only for the chip in master mode while the bus is released, the BGR signal is negated to indicate this. If the BRLS signal is continuously asserted, the bus release state is maintained.

7.11.2 Access as Seen from the CPU or DMAC

The SH7604 is internally divided into three buses: cache, internal, and peripheral. The CPU and cache memory are connected to the cache bus, the DMAC and bus state controller are connected to the internal bus, and the low-speed peripherals and mode registers are connected to the peripheral bus. The user break controller is connected to both the cache bus and the internal bus. The internal bus can be accessed from the cache bus, but not the other way around. The peripheral bus can be accessed from the internal bus, but not the other way around. This results in the following.

Data cannot be written from the DMAC to cache memory. When the DMAC causes a write to memory, the contents of memory and the cache contents will be different. To rewrite the contents of memory, the cache memory must be purged by software if the possibility exists that the data for that address exists in the cache.

When the CPU starts a read access to a cache area, it first takes a cycle to find the cache. If there is data in the cache, it fetches it and completes the access. If there is no data in the cache, a cache data fill is performed via the internal bus, so four consecutive longword reads occur. For misses that occur when byte or word operands are accessed or branches occur to odd word boundaries ($4n + 2$ addresses), filling is always performed by longword accesses on the chip-external interface. In the cache-through area, the access is to the actual access address. When the access is an instruction fetch, the access size is always longword.

For cache-through areas and on-chip peripheral module read cycles, after an extra cycle is added to determine the cycle, the read cycle is started through the internal bus. Read data is sent to the CPU through the cache bus.

When word write cycles access the cache area, the cache is searched. When the data of the relevant address is found, it is written here. In parallel to this, the actual writing occurs through the internal bus. When the right to use the internal bus is held, the CPU is notified that the write is completed without waiting for the actual writing to the on-chip peripheral module or off the chip to end. When the right to use the internal bus is not held, as when it is being used by the DMAC or the like, there is a wait until the bus is acquired before the CPU is notified of completion.

Accesses to cache-through areas and on-chip peripheral modules work the same as in the cache area, except for the cache search and write.

Because the bus state controller has one level of write buffer, the internal bus can be used for another access even when the chip-external bus cycle has not ended. After a write has been performed to low-speed memory off the chip, performing a read or write with an on-chip peripheral module enables an access to the on-chip peripheral module without having to wait for the completion of the write to low-speed memory.

During reads, the CPU always has to wait for the end of the operation. To immediately continue processing after checking that the write to the device of actual data has ended, perform a dummy read access to the same address consecutively to check that the write has ended.

The bus state controller's write buffer functions in the same way during accesses from the DMAC. A dual-address DMA transfer thus starts in the next read cycle without waiting for the end of the write cycle. When both the source address and destination address of the DMA are external spaces to the chip, however, it must wait until the completion of the previous write cycle before starting the next read cycle.

When using the SH7604's emulator, operation differs from real chip operation in the following ways.

To get trace data with the emulator, all accesses performed by the CPU and DMAC must be output externally. It is not possible to completely analyze program execution or the contents of the data accessed with only traces of access cycles performed exterior to the chip.

Reads of the cache from the CPU can be performed using only the cache bus, but the access address and data read must be able to use the internal bus and external bus to be output externally. The external bus is not needed to access on-chip peripheral modules with the CPU or DMAC, but it is needed to output trace data. This means that when the emulator is used in the trace data fetch mode, internal access operations of the CPU or DMAC are not performed in parallel with the external bus cycle, so extra execution time is required compared to actual chips. Parallel execution of accesses that follow writing to external destinations also should be executed after writing is completed to carry out traces. To precisely measure the actual execution time, an actual chip rather than an emulator should be used.

DataSheet4U.com

et4U.com

DataShee

DataSheet4U.com

www.DataSheet4U.com

Section 8 Cache

8.1 Introduction

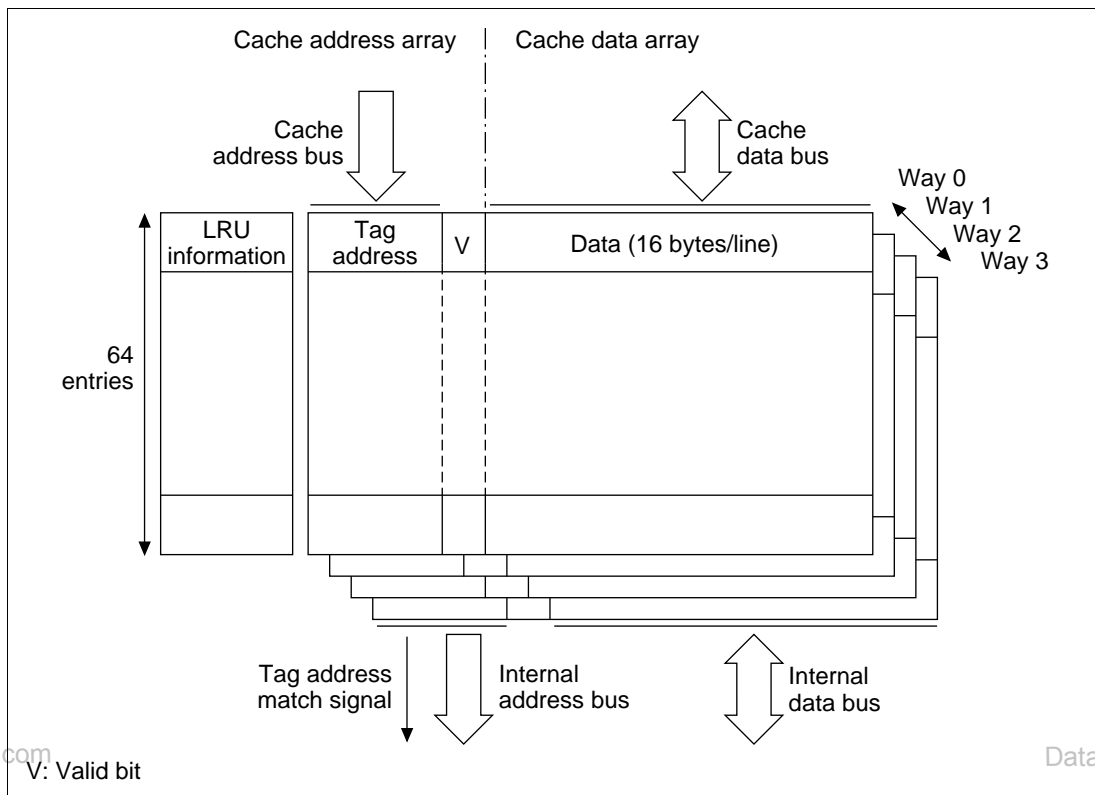

Figure 8.1 Cache Configuration

The SH7604 incorporates 4 kbytes of 4-way cache memory of mixed instruction/data type. The SH7604 can also be used as 2-kbyte RAM and 2-kbyte cache memory (mixed instruction/data type) by a setting in the cache control register CCR (two-way cache mode). CCR can specify that either instructions or data do not use cache.

Each line of cache memory consists of 16 bytes. Cache memory is always updated in line units. Four 32-bit accesses are required to update a line. Since the number of entries is 64, the six bits (A9 to A4) in each address determine the entry. A four-way set associative configuration is used, so up to four different instructions/data can be stored in the cache even when entry addresses match. To efficiently use four ways having the same entry address, replacement is provided based on a pseudo-LRU (least-recently used) replacement algorithm.

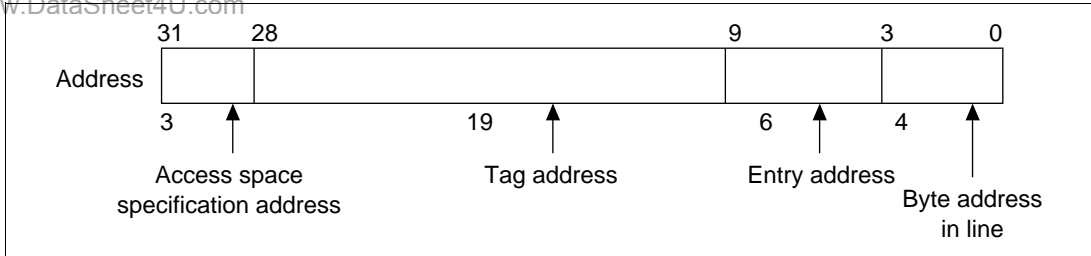

Figure 8.2 Address

8.2 Cache Control Register (CCR)

Table 8.1 Cache Control Register

Name	Abbrev.	R/W	Initial Value	Address
Cache control register	CCR	R/W	H'00	H'FFFFFFE92

The cache control register (CCR) is used for cache control. CCR must be set and the cache must be initialized before use.

Bit:	7	6	5	4	3	2	1	0
Bit name:	W1	W0	—	CP	TW	OD	ID	CE
Initial value:	0	0	0	0	0	0	0	0
R/W:	R/W	R/W	R	R/W	R/W	R/W	R/W	R/W

- Bits 7 and 6—Way Specification (W1 to W0): W1 and W0 specify the way when an address array is directly accessed by address specification.

Bit 7: W1	Bit 6: W0	Description
0	0	Way 0 (Initial value)
	1	Way 1
1	0	Way 2
	1	Way 3

- Bit 5—Reserved: This bit always reads 0. The write value should always be 0.
- Bit 4—Cache Purge (CP): CP is a cache purge bit. When 1 is written to CP, all cache entries and all valid bits and LRU bits of the way are initialized to 0. After initialization is complete, the CP bit reverts to 0. The CP bit always reads 0.

Bit 4: CP	Description	
0	Normal operation	(Initial value)
1	Cache purge	

Note: Always read 0.

- Bit 3—Two-Way Mode (TW): TW is the two-way mode bit. The cache operates as a four-way set associative cache when TW is 0 and as a two-way set associative cache and 2-kbyte RAM when TW is 1. In the two-way mode, ways 2 and 3 are cache and ways 0 and 1 are RAM. Ways 0 and 1 are read or written by direct access of the data array according to address space specification.

Bit 3: TW	Description	
0	Four-way mode	(Initial value)
1	Two-way mode	

- Bit 2—Data Replacement Disable (OD): OD is the bit for disabling data replacement. When this bit is 1, data fetched from external memory is not written to the cache even if there is a cache miss. Cache data is, however, read or updated during cache hits. OD is valid only when CE is 1.

Bit 2: OD	Description	
0	Normal operation	(Initial value)
1	Data not replaced even when cache miss occurs in data access	

- Bit 1—Instruction Replacement Disable (ID): ID is the bit for disabling instruction replacement. When this bit is 1, an instruction fetched from external memory is not written to the cache even if there is a cache miss. Cache data is, however, read or updated during cache hits. ID is valid only when CE is 1.

Bit 1: ID	Description	
0	Normal operation	(Initial value)
1	Data not replaced even when cache miss occurs in instruction fetch	

- Bit 0—Cache Enable (CE): CE is the cache enable bit. Cache can be used when CE is set to 1.

Bit 0: CE	Description	
0	Cache disabled	(Initial value)
1	Cache enabled	

8.3 Address Space and the Cache

The address space is divided into six partitions. The cache access operation is specified by addresses. Table 8.2 lists the partitions and their cache operations. For more information on address spaces, see section 7, Bus State Controller. Note that the spaces of the cache area and cache-through area are the same.

Table 8.2 Address Space and Cache Operation

Addresses A31–A29	Partition	Cache Operation
000	Cache area	Cache is used when the CE bit in CCR is 1.
001	Cache-through area	Cache is not used.
010	Associative purge area	Cache line of the specified address is purged (disabled).
011	Address array read/write area	Cache address array is accessed directly.
110	Data array read/write area	Cache data array is accessed directly.
111	I/O area	Cache is not used.

8.4 Cache Operation

8.4.1 Cache Reads

This section describes cache operation when the cache is enabled and data is read from the CPU. One of the 64 entries is selected by the entry address part of the address output from the CPU on the cache address bus. The tag addresses of ways 0 through 3 are compared to the tag address parts of the addresses output from the CPU. A match to the tag address of a way is called a cache hit. In proper use, the tag addresses of each way differ from each other, and the tag address of only one way will match. When none of the way tag addresses match, it is called a cache miss. Tag addresses of entries with valid bits of 0 will not match in any case.

When a cache hit occurs, data is read from the data array of the way that was matched according to the entry address, the byte address within the line, and the access data size. The data is then sent to the CPU. The address output on the cache address bus is calculated in the CPU's instruction execution phase and the results of the read are written during the CPU's write-back stage. The cache address bus and cache data bus both operate as pipelines in concert with the CPU's pipeline structure. From address comparison to data read requires 1 cycle; since the address and data operate as a pipeline, consecutive reads can be performed at each cycle with no waits.

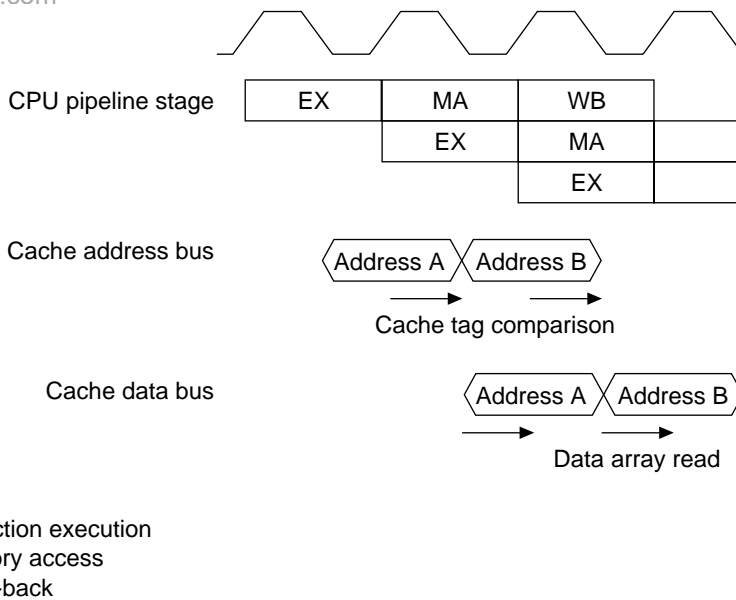

Figure 8.3 Read Access in Case of a Cache Hit

When a cache miss occurs, the way for replacement is determined using the LRU information, and the read address from the CPU is written in the address array for that way. Simultaneously, the valid bit is set to 1. Since the 16 bytes of data for replacing the data array are simultaneously read, the address on the cache address bus is output to the internal address bus and 4 longwords are read consecutively. Access starts with whatever address output to the internal address bus will make the longword that contains the address to be read from the cache come last as the byte address within the line as the order + 4. The data read on the internal data bus is written sequentially to the cache data array. When the last data is written to the cache data array, it is simultaneously written to the cache data bus and the read data is sent to the CPU.

The internal address bus and internal data bus also function as pipelines, just like the cache bus.

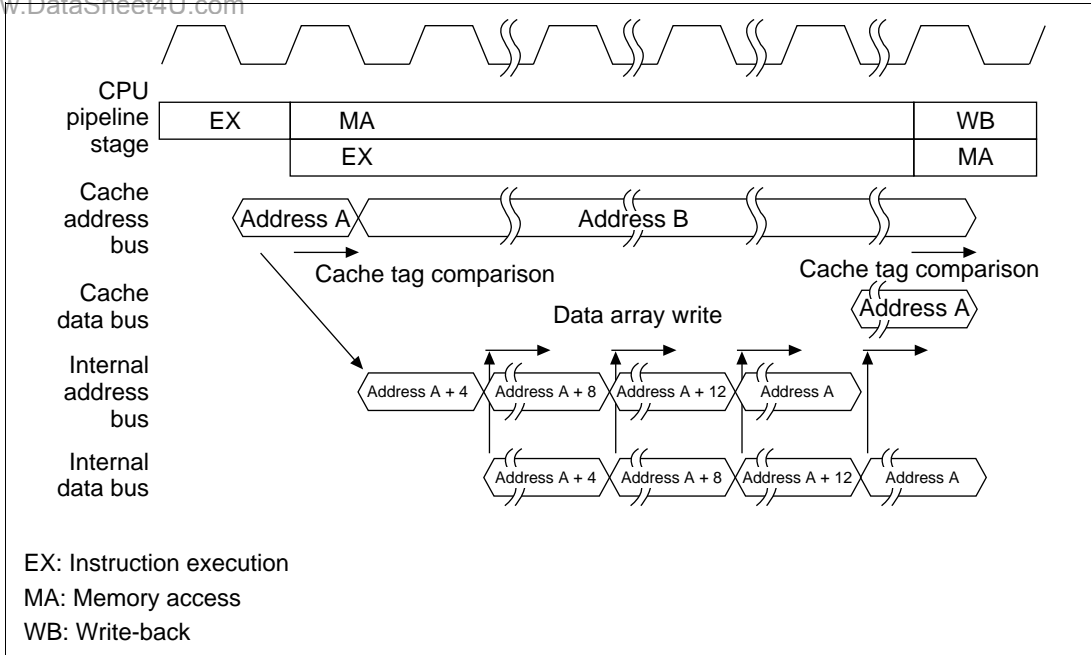

Figure 8.4 Read Access in Case of a Cache Miss

This cache is of the write-through type, and writing to external memory is performed regardless of whether or not there is a cache hit. The write address output to the cache address bus is used to compare to the tag address of the cache's address array. When they match, the write data output to the cache data bus in the following cycle is written to the data array. When they do not match, nothing is written to the cache data array. The write address is output to the internal address bus 1 cycle later than the cache address bus. The write data is similarly output to the internal data bus 1 cycle later than the cache data bus. The CPU waits until the writes onto the internal bus are completed.

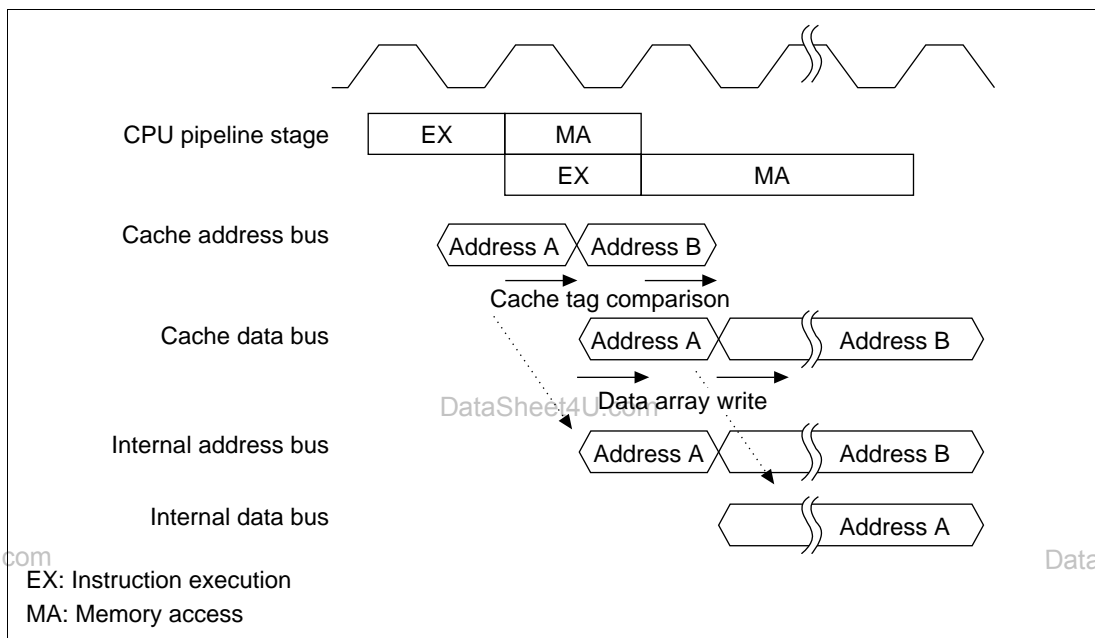

Figure 8.5 Write Access

8.4.3 Cache-Through Access

When reading or writing a cache-through area, the cache is not accessed. Instead, the cache address value is output to the internal address bus. For read operations, the read data output to the internal address bus is fetched and output to the cache data bus. The read of the cache-through area is only performed on the address in question. For write operations, the write data on the cache data bus is output to the internal data bus. Writes on the cache through area are compared to the address tag; except for the fact that nothing is written to the data array, the operation is the same as the write shown in figure 8.5.

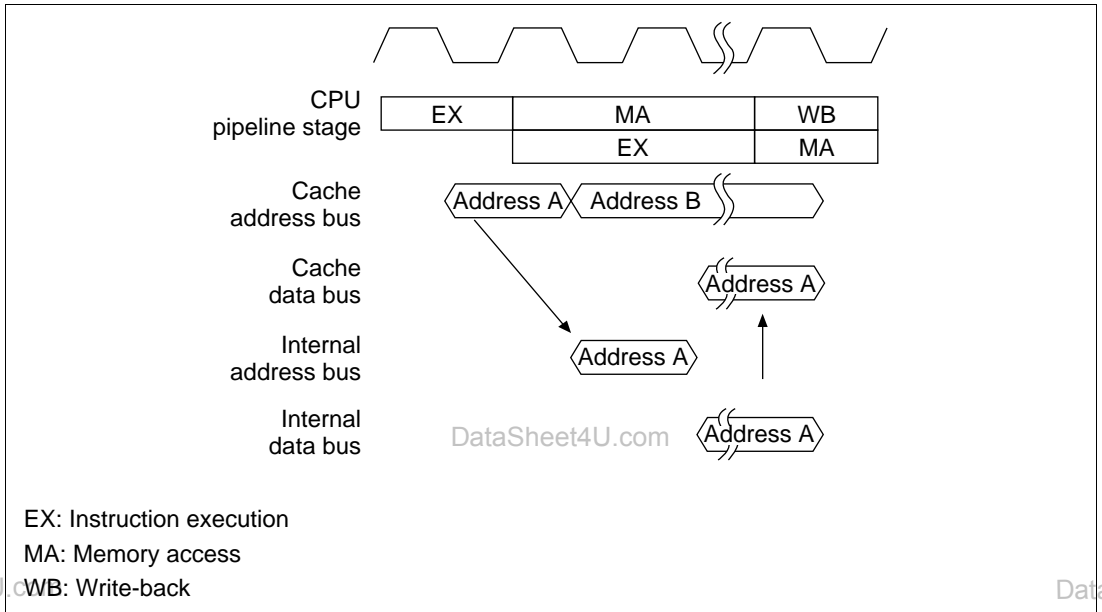

Figure 8.6 Reading Cache-Through Areas

8.4.4 The TAS Instruction

The TAS instruction reads data from memory, compares it to 0, and reflects the result in the T bit of the status register while setting the most significant bit to 1. It is an address for writing to the same address. Reads from memory become cache-through operations even when the cache area is accessed. Address tags are not compared. The updated value is written to memory through the internal data bus, but before that the address tag is compared and if there are any matching entries, a write is performed to the corresponding data array.

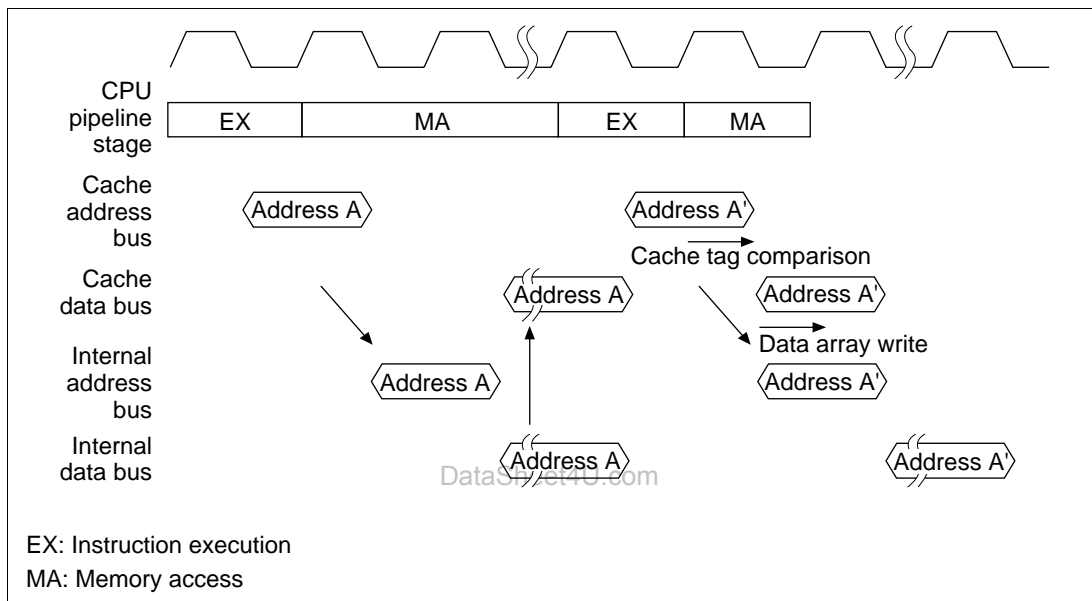

Figure 8.7 TAS Instruction Execution and the Cache

8.4.5 Pseudo-LRU and Cache Replacement

When a cache miss occurs during a read, the data of the missed address is read from 1 line (16 bytes) of memory and replaced. This makes it important to decide which of the ways to replace. It is likely that the way least recently used has the highest probability of being the next to be accessed. This algorithm for replacing ways is called the least recently used replacement algorithm, or LRU. The hardware to implement it, however, is complex. For that reason, this cache uses a pseudo-LRU replacement algorithm that keeps track of the order of way access and replaces the oldest way.

Six bits of data are used as the LRU information. The bits indicate the access order for 2 ways, as shown in figure 8.8. When the value is 1, access occurred in the direction of the appropriate arrow in the figure. The direction of the arrow can be determined by reading the bit. All the arrows show the oldest access toward that way, which becomes the object of replacement. The access order is recorded in the LRU information bits, so the LRU information is rewritten when a cache hit occurs during a read, when a cache hit occurs during a write, and when replacement occurs after a cache miss. Table 8.3 shows the rewrite values; table 8.4 shows how ways are selected for replacement.

After a cache purge by CCR's CP bit, the LRU information is completely zeroized, so the initial order used is way 3 → way 2 → way 1 → way 0. Thereafter the way is selected according to the order of access set by the program. Since the replacement will not be correct if the LRU gets an inappropriate value, the address array write function can be used to rewrite. When this is done, be sure not to write a value other than 0 as the LRU information.

When CCR's OD bit or ID bit is 1, neither will replace the cache even if a cache miss occurs during data read or instruction fetch. Instead of replacing, the missed address data is read and directly transferred to the CPU.

The two-way mode of the cache set by CCR's TW bit can only be implemented by replacing ways 2 and 3. Comparisons of tag addresses of address arrays are carried out on all four ways even in two-way mode, so the valid bit of ways 1 and 0 must be zeroized prior to operation in the two-way mode.

Writing for the tag address and valid bit for cache replacement does not wait for the read from memory to be completed. When the memory access is aborted by a reset during replacement or the like, the cache contents and memory contents may be out of sync, so always perform a purge.

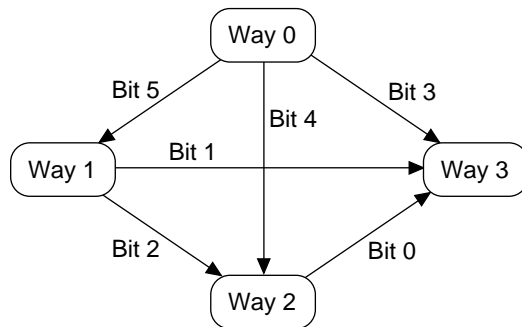

Figure 8.8 LRU Information and Access Sequence

Table 8.3 LRU Information after Update

	Bit 5	Bit 4	Bit 3	Bit 2	Bit 1	Bit 0
Way 0	0	0	0	—	—	—
Way 1	1	—	—	0	0	—
Way 2	—	1	—	1	—	0
Way 3	—	—	1	—	1	1

—: Holds the value before update.

Table 8.4 Selection Conditions for Replaced Way

	Bit 5	Bit 4	Bit 3	Bit 2	Bit 1	Bit 0
Way 0	1	1	1	—	—	—
Way 1	0	—	—	1	1	—
Way 2	—	0	—	0	—	1
Way 3	—	—	0	—	0	0

—: Don't care.

8.4.6 Cache Initialization

Purges of the entire cache area can only be carried out by writing 0 to the CP bit in CCR. Writing 1 to the CP bit initializes the valid bit of the address array and all bits of the LRU information to 0. Cache purges are completed in 1 cycle, but additional time is required for writing to CCR. Always initialize the valid bit and LRU before enabling the cache.

When the cache is enabled, instruction reads are performed from the cache even during writing to CCR. This means that the prefetched instructions are read from the cache. To do a proper purge, write 0 to CCR's CE bit, then disable the cache and purge. Since CCR's CE bit is cleared to 0 by a power-on reset or manual reset, the cache can be purged immediately by a reset.

8.4.7 Associative Purges

Associative purges invalidate 1 line (16 bytes) corresponding to specific address contents when the contents are in the cache. When the contents of shared addresses are rewritten by one CPU in a multiprocessor configuration, the other CPU cache must be invalidated if it also contains the address. When writing is performed to the address found by adding H'40000000 to the purged address, the valid bit of the entry storing the address prior to the addition is initialized to 0. 16 bytes are purged in each write, so a purge of 256 bytes of consecutive areas can be accomplished in 16 writes. Access sizes when associative purges are performed should be longword. A purge of 1 line requires 2 cycles.

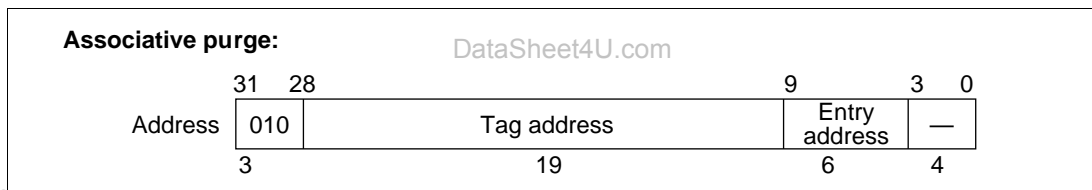

Figure 8.9 Associative Purge Access

8.4.8 Data Array Access

The cache data array can be read or written directly via the data array read/write area. The access sizes for the data array may be byte, word or longword. Data array accesses are completed in 1 cycle for both reads and writes. Since only the cache bus is used, the operation can proceed in parallel even when another master, such as the DMAC, is using the bus. The data array of way 0 is mapped on H'C0000000 to H'C00003FF, way 1 on H'C0000400 to H'C00007FF, way 2 on H'C0000800 to H'C0000BFF and way 3 on H'C0000C00 to H'C0000FFF. When the two-way mode is being used, the area H'C0000000 to H'C00007FF is accessed as 2 kbytes of on-chip RAM. When the cache is disabled, the area H'C0000000 to H'C0000FFF can be used as 4 kbytes of on-chip RAM.

When the contents of the way being used as cache is rewritten using a data array access, the contents of external memory and cache will not match, so this method should be avoided.

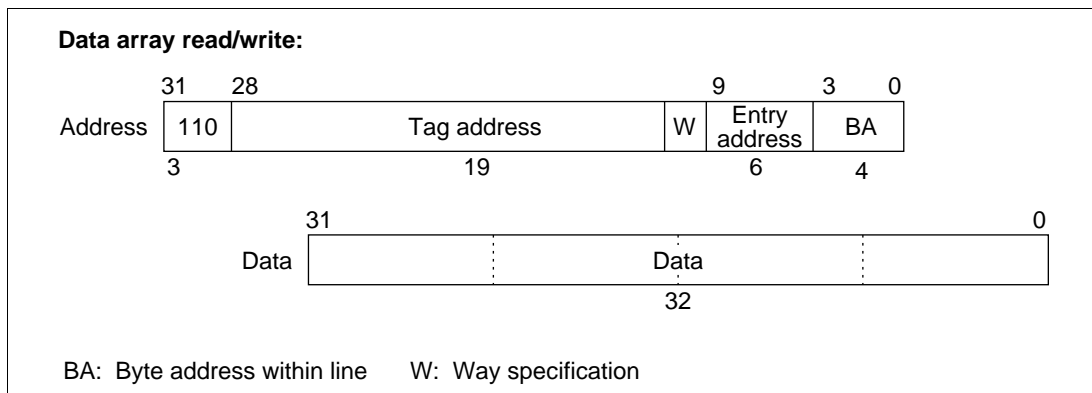
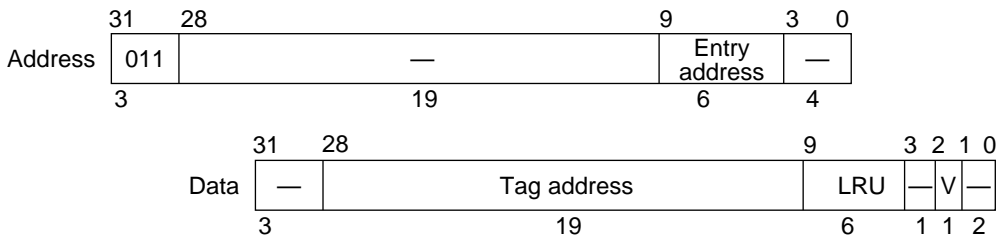
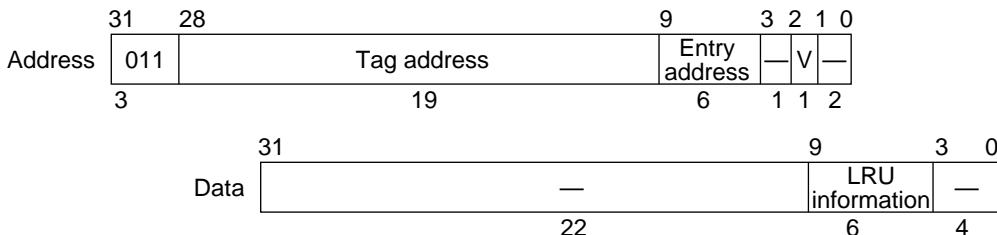

Figure 8.10 Data Array Access

8.4.9 Address Array Access

The address array of the cache can be accessed so that the contents fetched to the cache can be checked for purposes of program debugging or the like. The address array is mapped on H'60000000 to H'600003FF. Since all of the ways are mapped to the same addresses, ways are selected by rewriting the W1 and W0 bits in CCR. The address array can only be accessed in longwords.

When the address array is read, the tag address, LRU information, and valid bit are output as data. When the address array is written to, the tag address and valid bit are written from the cache address bus. This requires that the write address be calculated according to the value to be written, then written. LRU information is written from data, but 0 should always be written to prevent malfunctions.

Address array read:**Address array write:**

V: Valid bit

Figure 8.11 Address Array Access

DataSheet4U.com

8.5 Cache Use

8.5.1 Initialization

Cache memory is not initialized in a reset. Therefore, the cache must be initialized by software before use. Cache initialization clears (to 0) the address array valid bit and all LRU information. The address array write function can be used to initialize each line, but it is simpler to initialize it once by writing 1 to the CP bit in CCR. Figure 8.12 shows how to initialize the cache.

```

MOV.W  #H'FE92, R1
MOV.B  @R1, R0    ;
AND    #H'FE, R0  ;
MOV.B  #R0, @R1   ; Cache disable
OR     #H'10, R0
MOV.B  R0, @R1    ; Cache purge
OR     #H'01, R0
MOV.B  R0, R1     ; Cache enable

```

www.DataSheet4U.com

Figure 8.12 Cache Initialization

8.5.2 Purge of Specific Lines

Since the SH7604 has no snoop function (for monitoring data rewrites), specific lines of cache must be purged when the contents of cache memory and external memory differ as a result of an operation. For instance, when a DMA transfer is performed to the cache area, cache lines corresponding to the rewritten address area must be purged. All entries of the cache can be purged by setting the CP bit in CCR to 1. However, it is efficient to purge only specific lines if only a limited number of entries are to be purged.

An associative purge is used to purge specific lines. Since cache lines are 16 bytes long, purges are performed in a 16-byte units. The four ways are checked simultaneously, and only lines holding data corresponding to specified addresses are purged. When addresses do not match, the data at the specified address is not fetched to the cache, so no purge occurs.

```

; Purging 32 bytes from address R3
MOV.L    #H'40000000, R0
XOR      R1, R1
MOV.L    R1, @(R0, R3)
ADD      #16, R3
MOV.L    R1, @(R0, R3)

```

Figure 8.13 Purging Specific Addresses

DataSheet4U.com

When it is troublesome to purge the cache after every DMA transfer, it is recommended that the OD bit in CCR be set to 1 in advance. When the OD bit is 1, the cache operates as cache memory only for instructions. However, when data is already fetched into cache memory, specific lines of cache memory must be purged for DMA transfers.

et4U.com

DataShee

8.5.3 Cache Data Coherency

The SH7604's cache memory does not have a snoop function. This means that when data is shared with a bus master other than the CPU, software must be used to ensure the coherency of data. For this purpose, the cache-through area can be used, the break function can be used in external bus cycles, or a cache purge can be performed with program logic.

If the cache-through area is to be used, the data shared by the bus masters is placed in the cache-through area. This makes it easy to maintain data coherency, since access of the cache-through area does not fetch data into the cache. When the shared data is accessed repeatedly and the frequency of data rewrites is low, a lower access speed can adversely affect performance.

To use the external bus cycle break function, the user break controller is used. Set the user break controller to generate an interrupt when a write cycle is detected to any of the areas that have shared data. The interrupt handling routine purges the cache. Since the cache is purged whenever a

DataSheet4U.com

www.DataSheet4U.com

rewrite is detected, data coherency can be maintained. When data that extends over multiple words, such as a structure, is rewritten, however, interrupts are generated at the rewrites, which can lower performance. This method is most appropriate for cases in which it is difficult to predict and detect the timing of data updates and the update frequency is low.

To purge the cache using program logic, the data updates are detected by the program flow and the cache is then purged. For example, if the program inputs data from a disk, whenever reading of a unit (such as a sector) is completed, the buffer address used for reading or the entire cache is purged, thereby maintaining coherency. When data is to be handled between two processors, only flags to provide mutual notification of completion of data preparation or completion of a fetch are placed in the cache-through area. The data actually transferred is placed in the cache area and the cache is purged before the first data read to maintain the coherency of the data. When semaphores are used as the means of communication, data coherency can be maintained even when the cache is not purged by utilizing the TAS instruction. The TAS instruction is not read within the cache; the external access is always direct. This means that data can be synchronized with other masters when it is read.

When the update unit is small, specific addresses can be purged, so only the relevant addresses are purged. When the update unit is larger, it is faster to purge the entire cache rather than purging all the addresses in order, and then read in the data previously existing in the cache again from external memory.

8.5.4 Two-Way Cache Mode DataSheet4U.com

The 4-kbyte cache can be used as 2-kbyte RAM and 2-kbyte mixed instruction/data cache memory by setting the TW bit in CCR to 1. Ways 2 and 3 become cache, and ways 0 and 1 become RAM.

The cache and RAM are initialized by setting the CP bit in CCR to 1. The valid bit and LRU bits are cleared to 0. DataSheet4U.com

When the initial values of the LRU information are set to 0, ways 3 and 2 are initially used, in that order. Ways 3 and 2 are subsequently selected for replacement as specified by the LRU information. The conditions for updating the LRU information are the same as for four-way mode, except that the number of ways is two.

When designated as 2-kbyte RAM, ways 0 and 1 are accessed by data array access. Figure 8.14 shows the address mapping.

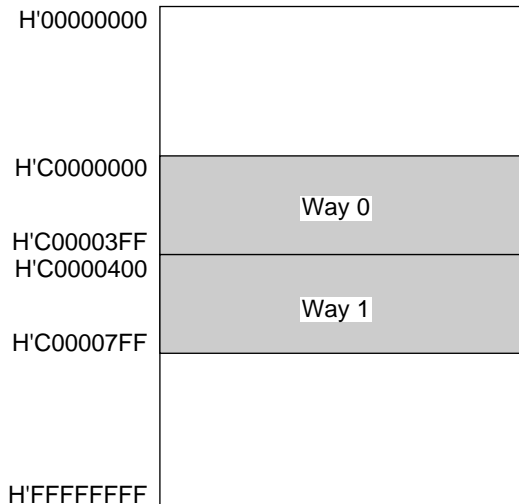

Figure 8.14 Address Mapping of 2-kbyte RAM in the Two-Way Mode

8.5.5 Usage Notes

Standby: Disable the cache before entering the standby mode for power-down operation. After returning from power-down, initialize the cache before use.

DataSheet4U.com

Cache Control Register: Changing the contents of CCR also changes cache operation. The SH7604 makes full use of pipeline operations, so it is difficult to synchronize access. For this reason, change the contents of the cache control register while disabling the cache or after the cache is disabled.

et4U.com

DataShee

DataSheet4U.com

et4U.com

DataShee

DataSheet4U.com

www.DataSheet4U.com

Section 9 Direct Memory Access Controller (DMAC)

9.1 Overview

The SH7604 includes a two-channel direct memory access controller (DMAC). The DMAC can be used in place of the CPU to perform high-speed data transfers between external devices equipped with DACK (transfer request acknowledge signal), external memories, memory-mapped external devices, and on-chip peripheral modules (except for the DMAC, BSC and UBC). Using the DMAC reduces the burden on the CPU and increases the operating efficiency of the chip as a whole.

9.1.1 Features

The DMAC has the following features:

- Number of channels: 2
- Address space: 4 Gbytes in the architecture
- Selectable data transfer unit: Byte, word (2 bytes), longword (4 bytes) or 16-byte unit (16-byte transfers first perform four longword reads and then four longword writes)
- Maximum transfer count: 16,777,216 (16M) transfers
- With cache hits, CPU instruction processing and DMA operation can proceed in parallel
- The maximum transfer rate for synchronous DRAM burst transfers is 38 Mbytes/sec ($f = 28.7$ MHz)
- Single address mode transfers: Either the transfer source or transfer destination (peripheral device) is accessed by a DACK signal (selectable) while the other is accessed by address. One transfer unit of data is transferred in each bus cycle.

Devices that can be used in DMA transfer:

- External devices with DACK and memory-mapped external devices (including external memories)
- Dual address mode transfers: Both the transfer source and transfer destination are accessed by address. One transfer unit of data is transferred in two bus cycles.

Device combinations capable of transfer:

- Two external memories
- External memory and memory-mapped external devices
- Two memory-mapped external devices
- External memory and on-chip peripheral module (excluding the DMAC, BSC and UBC).
- Memory-mapped external devices and on-chip peripheral modules (excluding the DMAC,

- Two on-chip peripheral modules (excluding the DMAC, BSC and UBC)
(access size permitted by a register of the peripheral module that is the transfer source or destination)
- Transfer requests
 - External requests (from DREQ pins. DREQ can be detected either by edge or by level, and either active-low or active-high can be selected)
 - On-chip peripheral module requests (serial communication interface (SCI))
 - Auto-request (the transfer request is generated automatically within the DMAC)
- Selectable bus modes: Cycle-steal mode or burst mode
- Selectable channel priority levels: Fixed or round-robin mode
- An interrupt request can be sent to the CPU when data transfer ends

DataSheet4U.com

et4U.com

DataShee

DataSheet4U.com

www.DataSheet4U.com

9.1.2 Block Diagram

Figure 9.1 shows a block diagram of the DMAC.

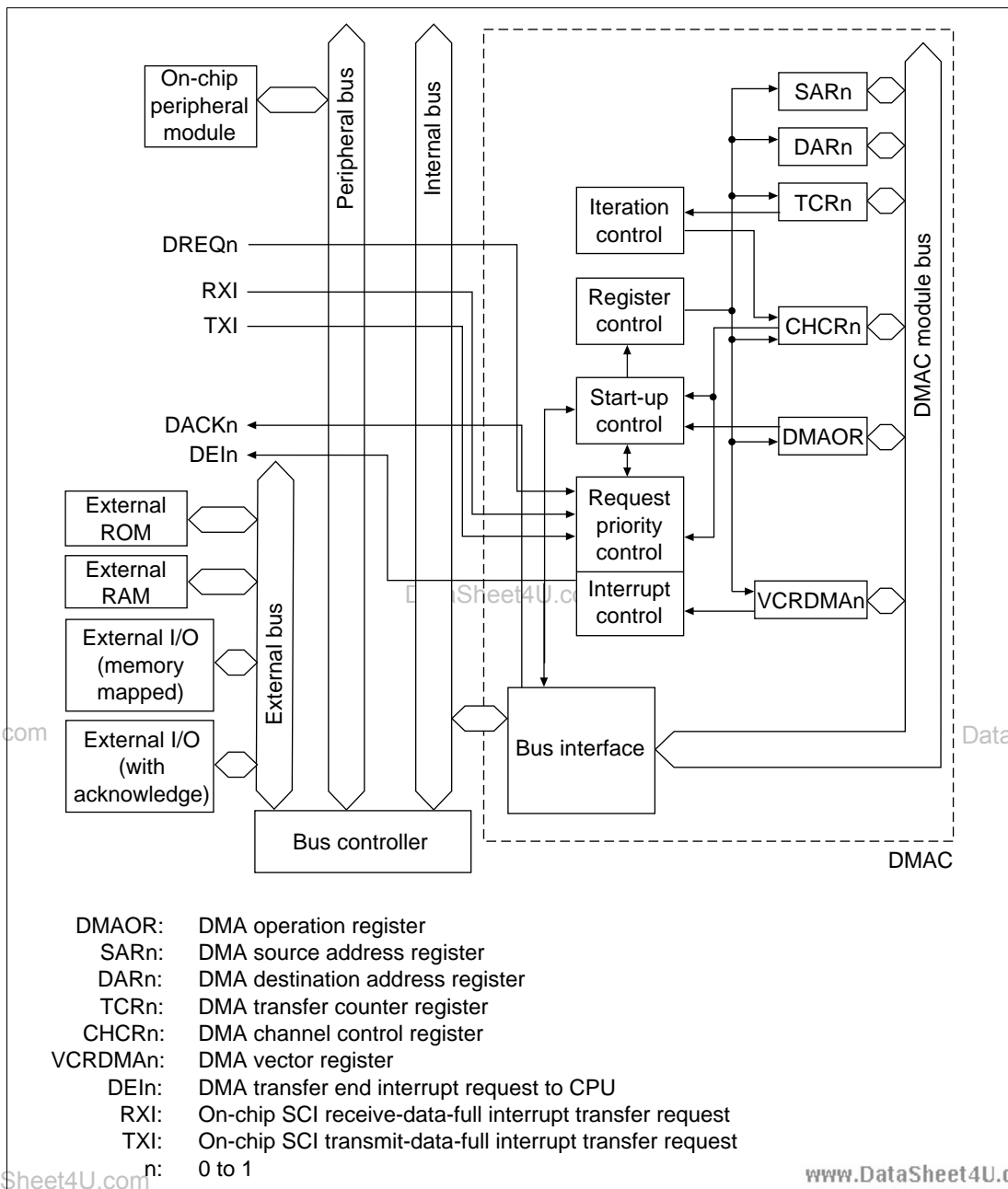

Figure 9.1 DMAC Block Diagram

9.1.3 Pin Configuration

Table 9.1 shows the DMAC pins.

Table 9.1 DMAC Pin Configuration

Channel	Name	Symbol	I/O	Function
0	DMA transfer request	DREQ0	I	DMA transfer request input from external device to channel 0
	DMA transfer request acknowledge	DACK0	O	DMA transfer request acknowledge output from channel 0 to external device
1	DMA transfer request	DREQ1	I	DMA transfer request input from external device to channel 1
	DMA transfer request acknowledge	DACK1	O	DMA transfer request acknowledge output from channel 1 to external device

9.1.4 Register Configuration

Table 9.2 summarizes the DMAC registers. The DMAC has a total of 13 registers. Each channel has six control registers. One control register is shared by both channels.

DataSheet4U.com

Table 9.2 DMAC Registers

Channel Name		Abbr.	R/W	Initial Value	Address	Access Size* ³
0	DMA source address register 0	SAR0	R/W	Undefined	H'FFFFFFF80	32
	DMA destination address register 0	DAR0	R/W	Undefined	H'FFFFFFF84	32
	DMA transfer count register 0	TCR0	R/W	Undefined	H'FFFFFFF88	32
	DMA channel control register 0	CHCR0	R/(W)* ¹	H'00000000	H'FFFFFFF8C	32
	DMA vector number register N0	VCRDMA0	R/(W)* ¹	Undefined	H'FFFFFFFA0	32
	DMA request/response selection control register 0	DRCR0	R/(W)* ¹	H'00	H'FFFFFFE71	8* ³
1	DMA source address register 1	SAR1	R/W	Undefined	H'FFFFFFF90	32
	DMA destination address register 1	DAR1	R/W	Undefined	H'FFFFFFF94	32
	DMA transfer count register 1	TCR1	R/W	Undefined	H'FFFFFFF98	32
	DMA channel control register 1	CHCR1	R/(W)* ¹	H'00000000	H'FFFFFFF9C	32
	DMA vector number register N1	VCRDMA1	R/(W)* ¹	Undefined	H'FFFFFFFA8	32
	DMA request/response selection control register 1	DRCR1	R/(W)* ¹	H'00	H'FFFFFFE72	8* ³
Shared	DMA operation register	DMAOR	R/(W)* ²	H'00000000	H'FFFFFFFB0	32

Notes: 1. Only 0 can be written to bit 1 of CHCR0 and CHCR1, after reading 1, to clear the flags.
 2. Only 0 can be written to bits 1 and 2 of the DMAOR, after reading 1, to clear the flags.
 3. Access DRCR0 and DRCR1 in byte units. Access all other registers in longword units.

et4U.com

DataShee

9.2 Register Descriptions

9.2.1 DMA Source Address Registers 0 and 1 (SAR0 and SAR1)

Bit:	31	30	29	...	3	2	1	0
Bit name:	<input type="text"/>	<input type="text"/>	<input type="text"/>	...	<input type="text"/>	<input type="text"/>	<input type="text"/>	<input type="text"/>
Initial value:	—	—	—	...	—	—	—	—
R/W:	R/W	R/W	R/W	...	R/W	R/W	R/W	R/W

DMA source address registers 0 and 1 (SAR0 and SAR1) are 32-bit read/write registers that specify the source address of a DMA transfer. During a DMA transfer, these registers indicate the next source address. (In single-address mode, SAR is ignored in transfers from external devices with DACK to memory-mapped external devices or external memory). In 16-byte unit transfers, always set the value of the source address to a 16-byte boundaries (16n address). Operation results

DataSheet4U.com

cannot be guaranteed if other values are used. The value after a reset is undefined. Values are retained in standby mode and during module standbys.

9.2.2 DMA Destination Address Registers 0 and 1 (DAR0 and DAR1)

Bit:	31	30	29	...	3	2	1	0
Bit name:				...				
Initial value:	—	—	—	...	—	—	—	—
R/W:	R/W	R/W	R/W	...	R/W	R/W	R/W	R/W

DMA destination address registers 0 and 1 (DAR0 and DAR1) are 32-bit read/write registers that specify the destination address of a DMA transfer. During a DMA transfer, these registers indicate the next destination address. (In single-address mode, DAR is ignored in transfers from memory-mapped external devices or external memory to external devices with DACK). The value after a reset is undefined. Values are retained in standby mode and during module standbys.

9.2.3 DMA Transfer Count Registers 0 and 1 (TCR0 and TCR1)

Bit:	31	30	29	28	27	26	25	24
Bit name:	—	—	—	—	—	—	—	—
Initial value:	0	0	0	0	0	0	0	0
R/W:	R	R	R	R	R	R	R	R

Bit:	23	22	21	...	3	2	1	0
Bit name:				...				
Initial value:	—	—	—	...	—	—	—	—
R/W:	R/W	R/W	R/W	...	R/W	R/W	R/W	R/W

DMA transfer count registers 0 and 1 (TCR0 and TCR1) are 32-bit read/write registers that specify the DMA transfer count. The lower 24 of the 32 bits are valid. The value is written as 32 bits, including the upper eight bits. The number of transfers is 1 when the setting is H'00000001, 16,777,215 when the setting is H'00FFFFFF and 16,777,216 (the maximum) when H'00000000 is set. During a DMA transfer, these registers indicate the remaining transfer count.

Set the initial value as the write value in the upper eight bits. These bits always read 0. The initial value after a reset is undefined. Values are retained in standby mode and during module standbys. For 16-byte transfers, set the count to 4 times the number of transfers.

9.2.4 DMA Channel Control Registers 0 and 1 (CHCR0 and CHCR1)

Bit:	31	30	29	...	19	18	17	16
Bit name:	—	—	—	...	—	—	—	—
Initial value:	0	0	0	...	0	0	0	0
R/W:	R	R	R	...	R	R	R	R
Bit:	15	14	13	12	11	10	9	8
Bit name:	DM1	DM0	SM1	SM0	TS1	TS0	AR	AM
Initial value:	0	0	0	0	0	0	0	0
R/W:	R/W	R/W	R/W	R/W	R/W	R/W	R/W	R/W
Bit:	7	6	5	4	3	2	1	0
Bit name:	AL	DS	DL	TB	TA	IE	TE	DE
Initial value:	0	0	0	0	0	0	0	0
R/W:	R/W	R/W	R/W	R/W	R/W	R/W	R/(W)*	R/W

Note: Only 0 can be written, to clear the flag.

DMA channel control registers 0 and 1 (CHCR0 and CHCR1) are 32-bit read/write registers that control the DMA transfer mode. They also indicate the DMA transfer status. Only the lower 16 of the 32 bits are valid. They are written as 32-bit values, including the upper 16 bits. Write the initial values to the upper 16 bits. These bits always read 0. The registers are initialized to H'00000000 by a reset and in standby mode. Values are retained during a module standby.

- Bits 15 and 14—Destination Address Mode Bits 1, 0 (DM1, DM0): Select whether the DMA destination address is incremented, decremented or left fixed (in single address mode, DM1 and DM0 are ignored when transfers are made from a memory-mapped external device, on-chip peripheral module, or external memory to an external device with DACK). DM1 and DM0 are initialized to 00 by a reset and in standby mode. Values are retained during a module standby.

Bit 15: DM1	Bit 14: DM0	Description
0	0	Fixed destination address (Initial value)
	1	Destination address is incremented (+1 for byte transfer size, +2 for word transfer size, +4 for longword transfer size, +16 for 16-byte transfer size)
1	0	Destination address is decremented (−1 for byte transfer size, −2 for word transfer size, −4 for longword transfer size, −16 for 16-byte transfer size)
	1	Reserved (setting prohibited)

- Bits 13 and 12—Source Address Mode Bits 1, 0 (SM1, SM0): Select whether the DMA source address is incremented, decremented or left fixed. In single address mode, SM1 and SM0 are ignored when transfers are made from an external device with DACK to a memory-mapped external device, on-chip peripheral module, or external memory. For a 16-byte transfer, the address is incremented by +16 regardless of the SM1 and SM0 values. SM1 and SM0 are initialized to 00 by a reset and in standby mode. Values are retained during a module standby.

Bit 13: SM1	Bit 12: SM0	Description
0	0	Fixed source address (+16 for 16-byte transfer size) (Initial value)
	1	Source address is incremented (+1 for byte transfer size, +2 for word transfer size, +4 for longword transfer size, +16 for 16-byte transfer size)
1	0	Source address is decremented (−1 for byte transfer size, −2 for word transfer size, −4 for longword transfer size, +16 for 16-byte transfer size)
	1	Reserved (setting prohibited)

- Bits 11 and 10—Transfer Size Bits (TS1, TS0): Select the DMA transfer size. When the transfer source or destination is an on-chip peripheral module register for which an access size has been specified, that size must be selected. During 16-byte transfers, set the transfer address mode bit for dual address mode. TS1 and TS0 are initialized to 00 by a reset and in standby mode. Values are retained during a module standby.

Bit 11: TS1	Bit 10: TS0	Description
0	0	Byte unit (initial value)
	1	Word (2-byte) unit
1	0	Longword (4-byte) unit
	1	16-byte unit (4 longword transfers)

- Bit 9—Auto Request Mode Bit (AR): Selects whether auto-request (generated within the DMAC) or module request (an external request or from the on-chip SCI module) is used for the transfer request. The AR bit is initialized to 0 by a reset and in standby mode. Its value is retained during a module standby.

Bit 9: AR	Description
0	Module request mode (Initial value)
1	Auto-request mode

- Bit 8—Acknowledge/Transfer Mode Bit (AM): In dual address mode, this bit selects whether the DACK signal is output during the data read cycle or write cycle. In single-address mode, it selects whether to transfer data from memory to device or from device to memory. The AM bit is initialized to 0 by a reset and in standby mode. Its value is retained during a module standby.

Bit 8: AM	Description
0	DACK output in read cycle/transfer from memory to device (Initial value)
1	DACK output in write cycle/transfer from device to memory

- Bit 7—Acknowledge Level Bit (AL): Selects whether the DACK signal is an active-high signal or an active-low signal. The AL bit is initialized to 0 by a reset and in standby mode. Its value is retained during a module standby.

Bit 7: AL	Description
0	DACK is an active-low signal (Initial value)
1	DACK is an active-high signal

- Bit 6—DREQ Select Bit (DS): Selects the DREQ input detection method used. The DS bit is initialized to 0 by a reset and in standby mode. Its value is retained during a module standby.

Bit 6: DS	Description
0	Detected by level (Initial value)
1	Detected by edge

- Bit 5—DREQ Level Bit (DL): Selects active-high or active-low for the DREQ signal. The DL bit is initialized to 0 by a reset and in standby mode. Its value is retained during a module standby.

Bit 5: DL	Description
0	When DS is 0, DREQ is detected by low level; when DS is 1, DREQ is detected by fall (Initial value)
1	When DS is 0, DREQ is detected by high level; when DS is 1, DREQ is detected by rise

- Bit 4—Transfer Bus Mode Bit (TB): Selects the bus mode for DMA transfers. The TB bit is initialized to 0 by a reset and in standby mode. Its value is retained during a module standby.

Bit 4: TB	Description
0	Cycle-steal mode (Initial value)
1	Burst mode

- Bit 3—Transfer Address Mode Bit (TA): Selects the DMA transfer address mode. The TA bit is initialized to 0 by a reset and in standby mode. Its value is retained during a module standby.

Bit 3: TA	Description
0	Dual address mode (Initial value)
1	Single address mode

- Bit 2—Interrupt Enable Bit (IE): Determines whether or not to request a CPU interrupt at the end of a DMA transfer. When the IE bit is set to 1, an interrupt (DEI) request is sent to the CPU when the TE bit is set. The IE bit is initialized to 0 by a reset and in standby mode. Its value is retained during a module standby.

Bit 2: IE	Description
0	Interrupt disabled (Initial value)
1	Interrupt enabled

- Bit 1—Transfer-End Flag Bit (TE): Indicates that the transfer has ended. When the value in the DMA transfer count register (TCR) becomes 0, the DMA transfer ends normally and the TE bit is set to 1. This flag is not set if the transfer ends because of an NMI interrupt or DMA address error, or because the DME bit of the DMA operation register (DMAOR) or the DE bit was cleared. To clear the TE bit, read 1 from it and then write 0. When the TE bit is set, setting the DE bit to 1 will not enable a transfer. The TE bit is initialized to 0 by a reset and in standby mode. Its value is retained during a module standby.

Bit 1: TE	Description
0	DMA has not ended or was aborted (Initial value) Cleared by reading 1 from the TE bit and then writing 0
1	DMA has ended normally (by TCR = 0)

- Bit 0—DMA Enable Bit (DE): Enables or disables DMA transfers. In auto-request mode, the transfer starts when this bit or the DME bit in DMAOR is set to 1. The NMIF and AE bits in DMAOR and the TE bit must be all set to 0. In external request mode or on-chip peripheral module request mode, the transfer begins when the DMA transfer request is received from the relevant device or on-chip peripheral module, provided this bit and the DME bit are set to 1. As with the auto-request mode, the TE bit and the NMIF and AE bits in DMAOR must be all set to 0. The transfer can be stopped by clearing this bit to 0. The DE bit is initialized to 0 by a reset and in standby mode. Its value is retained during a module standby.

Bit 0: DE	Description
0	DMA transfer disabled (Initial value)
1	DMA transfer enabled

9.2.5 DMA Vector Number Registers 0 and 1 (VCRDMA0, VCRDMA1)

Bit:	31	30	29	...	11	10	9	8
Bit name:	—	—	—	...	—	—	—	—
Initial value:	0	0	0	...	0	0	0	0
R/W:	R	R	R	...	R	R	R	R
Bit:	7	6	5	4	3	2	1	0
Bit name:	VC7	VC6	VC5	VC4	VC3	VC2	VC1	VC0
Initial value:	—	—	—	—	—	—	—	—
R/W:	R/W	R/W	R/W	R/W	R/W	R/W	R/W	R/W

DMA vector number registers 0 and 1 (VCRDMA0, VCRDMA1) are 32-bit read/write registers that set the DMAC transfer-end interrupt vector number. Only the lower eight bits of the 32 are effective. They are written as 32-bit values, including the upper 24 bits. Write the initial values to the upper 24 bits. These bits are initialized to H'000000XX (last eight bits are undefined) by a reset and in standby mode. Values are retained during a module standby.

- Bits 31 to 8—Reserved: These bits always read 0. The write value should always be 0.

- Bits 7 to 0—Vector Number Bits 7–0 (VC7–VC0): Set the interrupt vector numbers at the end of a DMAC transfer. Interrupt vector numbers of 0–127 can be set. When a transfer-end interrupt occurs, exception handling and interrupt control fetch the vector number and control is transferred to the specified interrupt handling routine. The VC7–VC0 bits are undefined upon reset and in standby mode. Always write 0 to VC7.

9.2.6 DMA Request/Response Selection Control Registers 0 and 1 (DRCR0, DRCR1)

Bit:	7	6	5	4	3	2	1	0
Bit name:	—	—	—	—	—	—	RS1	RS0
Initial value:	0	0	0	0	0	0	0	0
R/W:	R	R	R	R	R	R	R/W	R/W

DMA request/response selection control registers 0 and 1 (DRCR0, DRCR1) are 8-bit read/write registers that set the vector address of the DMAC transfer request source. They are written as 8-bit values. They are initialized to H'00 by a reset, but retain their values in a module standby.

- Bits 7 to 2—Reserved
- Bits 1 and 0—Resource Select Bits 1 and 0 (RS1, RS0): Specify which transfer request to input to the DMAC. Changing the transfer request source must be done when the DMA enable bit (DE) is 0. The RS1 and RS0 bits are initialized to 00 by a reset.

Bit 1: RS1	Bit 0: RS0	Description
0	0	DREQ (external request) (Initial value)
0	1	RX1 (on-chip SCI receive-data-full interrupt transfer request)*
1	0	TX1 (on-chip SCI transmit-data-empty interrupt transfer request)*
1	1	Reserved (setting prohibited)

Note: For RX2 and TX1, set for dual transfer mode.

The DREQ settings in CHCR are DS = 1 and DL = 0.

9.2.7 DMA Operation Register (DMAOR)

Bit:	31	30	29	...	11	10	9	8
Bit name:	—	—	—	...	—	—	—	—
Initial value:	0	0	0	...	0	0	0	0
R/W:	R	R	R	...	R	R	R	R

Bit:	7	6	5	4	3	2	1	0
Bit name:	—	—	—	—	PR	AE	NMIF	DMIE
Initial value:	0	0	0	0	0	0	0	0
R/W:	R	R	R	R	R/W	R/(W)*	R/(W)*	R/W

Note: Only 0 can be written, to clear the flag.

The DMA operation register (DMAOR) is a 32-bit read/write register that controls the DMA transfer mode. It also indicates the DMA transfer status. Only the lower four of the 32 bits are valid. DMAOR is written as a 32-bit value, including the upper 28 bits. Write the initial values to the upper 28 bits. These bits always read 0. DMAOR is initialized to H'00000000 by a reset and in standby mode.

- Bits 31 to 4—Reserved: These bits always read 0. The write value should always be 0.
- Bit 3—Priority Mode Bit (PR): Selects the priority level between channels when there are transfer requests for multiple channels. It is initialized to 0 by a reset and in standby mode. Its value is retained during a module standby.

Bit 3: PR	Description
0	Fixed priority (channel 0 > channel 1) (Initial value)
1	Round-robin (Top priority shifts to bottom after each transfer. The priority for the first DMA transfer after a reset is channel 1 > channel 0)

- Bit 2—Address Error Flag Bit (AE): This flag indicates that an address error has occurred in the DMAC. When the AE bit is set to 1, DMA transfer cannot be enabled even if the DE bit in the DMA channel control register (CHCR) is set to 1. To clear the AE bit, read 1 from it and then write 0. Operation is performed up to the DMAC transfer being executed when the address error occurred. AE is initialized to 0 by a reset and in standby mode.

Bit 2: AE	Description
0	No DMAC address error (Initial value) To clear the AE bit, read 1 from it and then write 0
1	Address error by DMAC

- **Bit 1—NMI Flag Bit (NMIF):** This flag indicates that an NMI interrupt has occurred. When the NMIF bit is set to 1, DMA transfer cannot be enabled even if the DE bit in CHCR and the DME bit are set to 1. To clear the NMIF bit, read 1 from it and then write 0. Ends after the DMAC operation executing when the NMI comes in (operation goes to destination). When the NMI interrupt is input while the DMAC is not operating, the NMIF bit is set to 1. The NMIF bit is initialized to 0 by a reset or in the standby mode. Values are held during a module standby.

Bit 1: NMIF	Description
0	No NMIF interrupt (initial value) To clear the NMIF bit, read 1 from it and then write 0.
1	NMIF has occurred

- **Bit 0—DMA Master Enable Bit (DME):** Enables or disables DMA transfers on all channels. A DMA transfer becomes enabled when the DE bit in the CHCR and the DME bit are set to 1. For this to be effective, however, the TE bit in CHCR and the NMIF and AE bits must all be 0. When the DME bit is cleared, all channel DMA transfers are aborted. DME is initialized to 0 by a reset and in standby mode. Its value is retained during a module standby.

Bit 0: DME	Description
0	DMA transfers disabled on all channels (Initial value)
1	DMA transfers enabled on all channels

9.3 Operation

When there is a DMA transfer request, the DMAC starts the transfer according to the predetermined channel priority; when the transfer-end conditions are satisfied, it ends the transfer. Transfers can be requested in three modes: auto-request, external request, and on-chip module request. A transfer can be in either single address mode or dual address mode. The bus mode can be either burst or cycle-steal.

9.3.1 DMA Transfer Flow

After the DMA source address registers (SAR), DMA destination address registers (DAR), DMA transfer count registers (TCR), DMA channel control registers (CHCR), DMA vector number registers (VCRDMA), DMA request/response selection control registers (DRCR), and DMA operation register (DMAOR) are initialized (initializing sets each register so that ultimately the condition (DE = 1, DME = 1, TE = 0, NMIF = 0, AE = 0) is satisfied), the DMAC transfers data according to the following procedure:

1. Checks to see if transfer is enabled (DE = 1, DME = 1, TE = 0, NMIF = 0, AE = 0)
2. When a transfer request comes and transfer is enabled, the DMAC transfers 1 transfer unit of data. (In auto-request mode, the transfer begins automatically when the DE bit and DME bit are set to 1. The TCR value will be decremented by 1.) The actual transfer flows vary depending on the address mode and bus mode.
3. When the specified number of transfers have been completed (when TCR reaches 0), the transfer ends normally. If the IE bit in CHCR is set to 1 at this time, a DEI interrupt is sent to the CPU.
4. When an address error occurs in the DMAC or an NMI interrupt is generated, the transfer is aborted. Transfers are also aborted when the DE bit in CHCR or the DME bit in DMAOR is changed to 0.

Figure 9.2 shows a flowchart illustrating this procedure.

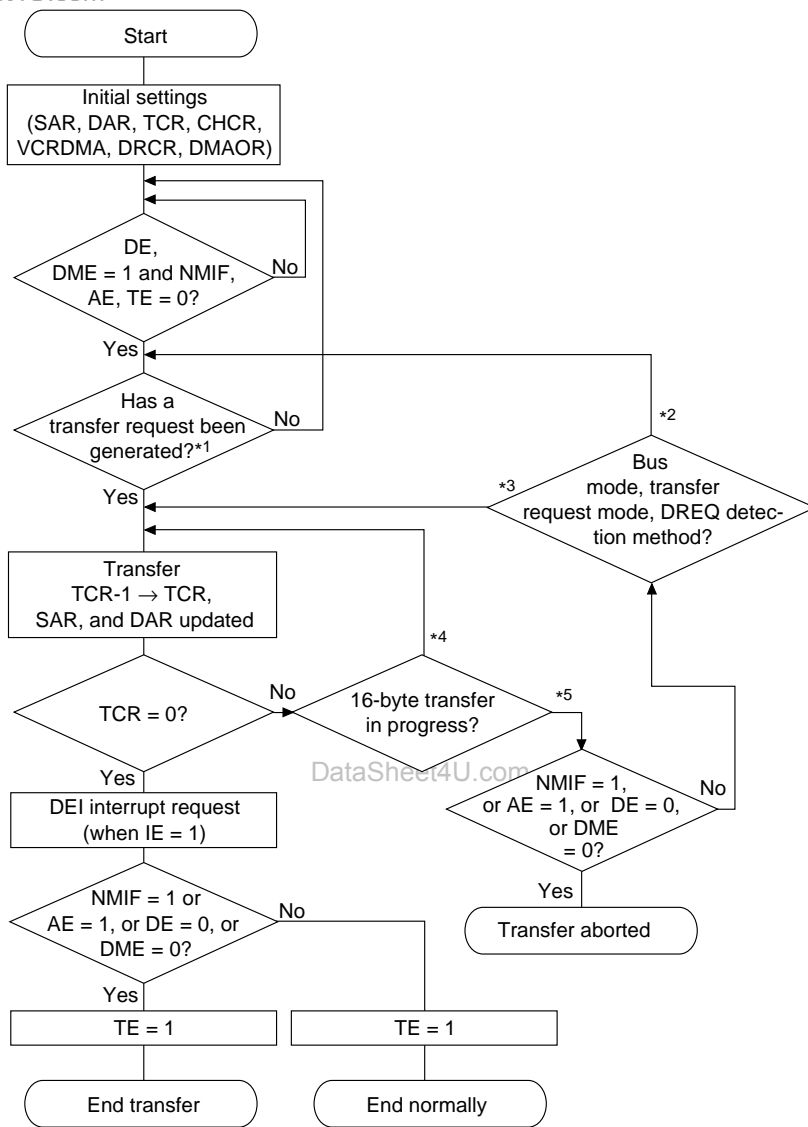

Notes: 1. In auto-request mode, the transfer will start when the NMIF, AE, and TE bits are all 0 and the DE and DME bits are then set to 1.

2. In burst mode, DREQ = level detection (external request), or cycle-steal mode.

3. In burst mode, DREQ = edge detection (external request), or auto-request mode in burst mode.

4. 16-byte transfer cycle in progress.

5. End of a 16-byte transfer cycle.

Figure 9.2 DMA Transfer Flow

9.3.2 DMA Transfer Requests

DMA transfer requests are usually generated in either the data transfer source or destination, but they can also be generated by devices that are neither the source nor the destination. Transfers can be requested in three modes: auto-request, external request, and on-chip peripheral module request. The request mode is selected with the AR bit in DMA channel control registers 0 and 1 (CHCR0, CHCR1) and the RS0 and RS1 bits in DMA request/response selection control registers 0 and 1 (DRCR0, DRCR1).

Table 9.3 Selecting the DMA Transfer Request Using the AR and RS Bits

CHCR	DRCR		Request Mode	Resource Select
	RS1	RS0		
0	0	0	Module request mode	DREQ external request (external request mode)
	0	1		RXI (SCI receive) request
	1	0		TXI (SCI transmit) request
1	X	X	Auto-request mode	

Auto-Request: When there is no transfer request signal from an external source (as in a memory-to-memory transfer or a transfer between memory and an on-chip peripheral module unable to request a transfer), the auto-request mode allows the DMAC to automatically generate a transfer request signal internally. When the DE bits in CHCR0 and CHCR1 and the DME bit in the DMA operation register (DMAOR) are set to 1, the transfer begins (so long as the TE bits in CHCR0 and CHCR1 and the NMIF and AE bits in DMAOR are all 0).

External Request: In this mode a transfer is started by a transfer request signal (DREQ) from an external device. Choose one of the modes shown in table 9.4 according to the application system. When DMA transfer is enabled (DE = 1, DME = 1, TE = 0, NMIF = 0, AE = 0), a transfer is performed upon input of a DREQ signal.

Table 9.4 Selecting External Request Modes with the TA and AM Bits

CHCR		Transfer			
TA	AM	Address Mode	Acknowledge Mode	Source	Destination
0	0	Dual address mode	DACK output in read cycle	Any* ¹	Any* ¹
	1	Dual address mode	DACK output in write cycle	Any* ¹	Any* ¹
1	0	Single address mode	Data transferred from memory to device	External memory* ² or memory-mapped external device	External device with DACK
	1	Single address mode	Data transferred from device to memory	External device with DACK	External memory* ² or memory-mapped external device

Notes: 1. External memory, memory-mapped external device, on-chip peripheral module (excluding DMAC, BSC, and UBC)
 2. Except synchronous DRAM

Choose to detect DREQ either by the falling edge or by level using the DS and DL bits in CHCR0 and CHCR1 (DS = 0 is level detection, DS = 1 is edge detection; for edge detection, DL = 0 is rising edge, DL = 1 is falling edge; for level detection, DL = 0 is active-low, DL = 1 is active-high). The source of the transfer request does not have to be the data transfer source or destination.

DataSheet4U.com

Table 9.5 Selecting the External Request Signal with the DS and DL Bits

DRCR		
DS	DL	External Request
0	0	Level (active-low)
	1	Level (active-high)
1	0	Edge (falling)
	1	Edge (rising)

On-Chip Module Request: In this mode, transfers are started by the transfer request signal (interrupt request signal) of an on-chip peripheral module in the SH7064. The transfer request signals are the receive-data-full interrupt (RXI) and transmit-data-empty interrupt (TXI) of the serial communication interface (SCI) (table 9.6). If DMA transfer is enabled (DE = 1, DME = 1, TE = 0, NMIF = 0, AE = 0), DMA transfer starts upon the input of a transfer request signal.

When RXI (transfer request when the SCI's receive data buffer is full) is set as the transfer request, however, the transfer source must be the SCI's receive data register (RDR). Likewise, when TXI (transfer request when the SCI's transmit data buffer is empty) is set as the transfer request, the transfer destination must be the SCI's transmit data register (TDR).

Table 9.6 Selecting On-Chip Peripheral Module Request Mode with the AR and RS bits

AR	RS1	RS0	DMA Transfer Request Source	DMA Transfer Request Signal	Source	Destination	Bus Mode	DREQ Setting
0	0	1	SCI receiver	RXI (SCI receive-data-full transfer request)	RDR	Any*	Cycle-steal	Edge, active-low
0	1	0	SCI transmitter	TXI (SCI transmit-data-empty transfer request)	Any*	TDR	Cycle-steal	Edge, active-low

Note: External memory, memory-mapped external device, on-chip peripheral module (excluding DMAC, BSC, and UBC)

When outputting transfer requests from the SCI, its interrupt enable bits (TIE and RIE in SCR) must be set to output the interrupt signals. Note that transfer request signals from on-chip peripheral modules (interrupt request signals) are sent not just to the DMAC but to the CPU as well. When an on-chip peripheral module is specified as the transfer request source, set the priority level values in the interrupt priority level registers (IPRC–IPRE) of the interrupt controller (INTC) at or below the levels set in the I3–I0 bits of the CPU's status register so that the CPU does not accept the interrupt request signal.

The DMA transfer request signals shown in table 9.6 are automatically fetched when the corresponding DMA transfer is performed. If cycle-steal mode is used, a DMA transfer request (interrupt request) from any module will be cleared at the first transfer; if burst mode is used, it will be cleared at the last transfer.

9.3.3 Channel Priorities

When the DMAC receives simultaneous transfer requests on two channels, it selects a channel according to a predetermined priority order. There are two priority modes, fixed and round-robin. The channel priority is selected by the priority bit, PR, in the DMA operation register (DMAOR).

Fixed Priority Mode: In this mode, the relative channel priority levels are fixed. When PR is set to 0, the priority, high to low, is channel 0 > channel 1. Figure 9.3 shows an example of a transfer in burst mode.

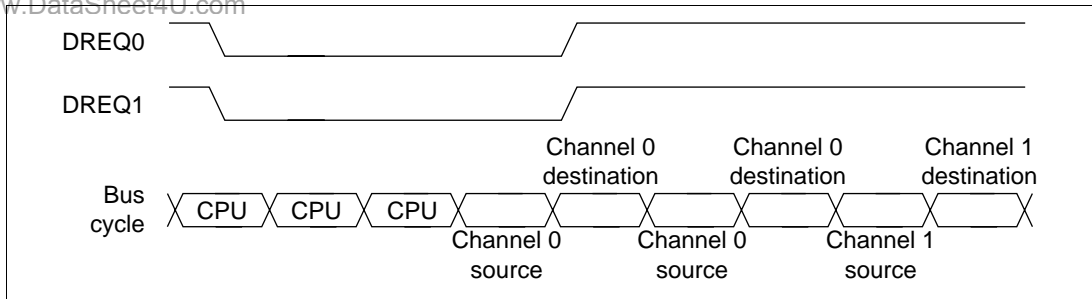

Figure 9.3 Fixed Mode Burst DMA Transfer (Dual Address, Active-Low DREQ Level)

In cycle-steal mode, once a channel 0 request is accepted, channel 1 requests are also accepted until the next request is made, which makes more effective use of the bus cycle. When requests come simultaneously for channel 0 and channel 1 when DMA operation is starting, the first is transmitted multiplexed with channel 0 and thereafter channel 1 and channel 0 transfers are performed alternately.

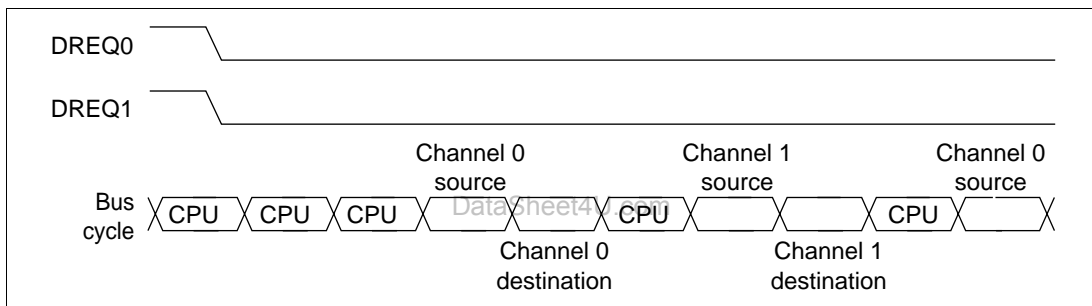

Figure 9.4 Fixed Mode Cycle-Steal DMA Transfer (Dual Address, Active-Low DREQ Level)

Round-Robin Mode: Switches the priority of channel 0 and channel 1, shifting their ability to receive transfer requests. Each time one transfer ends on one channel, the priority shifts to the other channel. The channel on which the transfer just finished is assigned low priority. After reset, channel 0 has higher priority than channel 1.

Figure 9.5 shows how the priority changes when channel 0 and channel 1 transfers are requested simultaneously and another channel 0 transfer is requested after the first two transfers end. The DMAC operates as follows:

1. Transfer requests are generated simultaneously to channels 1 and 0.
2. Channel 1 has the higher priority, so the channel 1 transfer begins first (channel 0 waits for transfer).
3. When the channel 1 transfer ends, channel 1 becomes the lower-priority channel.

4. The channel 0 transfer begins.
5. When the channel 0 transfer ends, channel 0 becomes the lower-priority channel.
6. A channel 0 transfer is requested.
7. The channel 0 transfer begins.
8. When the channel 0 transfer ends, channel 0 is already the lower-priority channel, so the order remains the same.

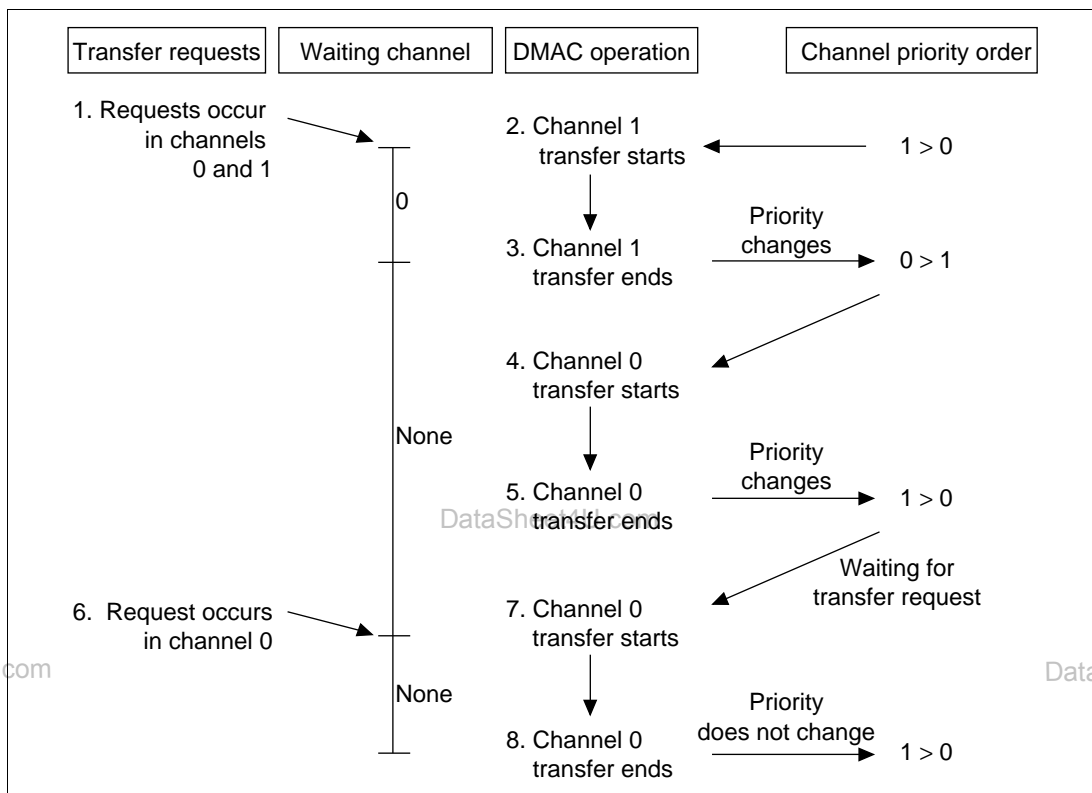

Figure 9.5 Channel Priority in Round-Robin Mode

9.3.4 DMA Transfer Types

The DMAC supports all the transfers shown in table 9.7. It can operate in single address mode or dual address mode, as defined by how many bus cycles the DMAC takes to access the transfer source and transfer destination. The actual transfer operation timing varies with the DMAC bus mode used: cycle-steal mode or burst mode.

Source	Destination			
	External Device with DACK	External Memory	Memory-Mapped External Device	On-Chip Peripheral Module
External device with DACK	Not available	Single	Single	Not available
External memory	Single	Dual	Dual	Dual
Memory-mapped external device	Single	Dual	Dual	Dual
On-chip peripheral module	Not available	Dual	Dual	Dual*

Single: Single address mode

Dual: Dual address mode

Note: Access size enabled by the register of the on-chip peripheral module that is the source or destination (excludes DMAC, BSC, and UBC).

Address Modes:

- Single Address Mode

In single address mode, both the transfer source and destination are external; one (selectable) is accessed by a DACK signal while the other is accessed by address. In this mode, the DMAC performs the DMA transfer in one bus cycle by simultaneously outputting a transfer request acknowledge DACK signal to one external device to access it while outputting an address to the other end of the transfer. Figure 9.6 shows an example of a transfer between external memory and external device with DACK. The external device outputs data to the data bus while that data is written in external memory in the same bus cycle.

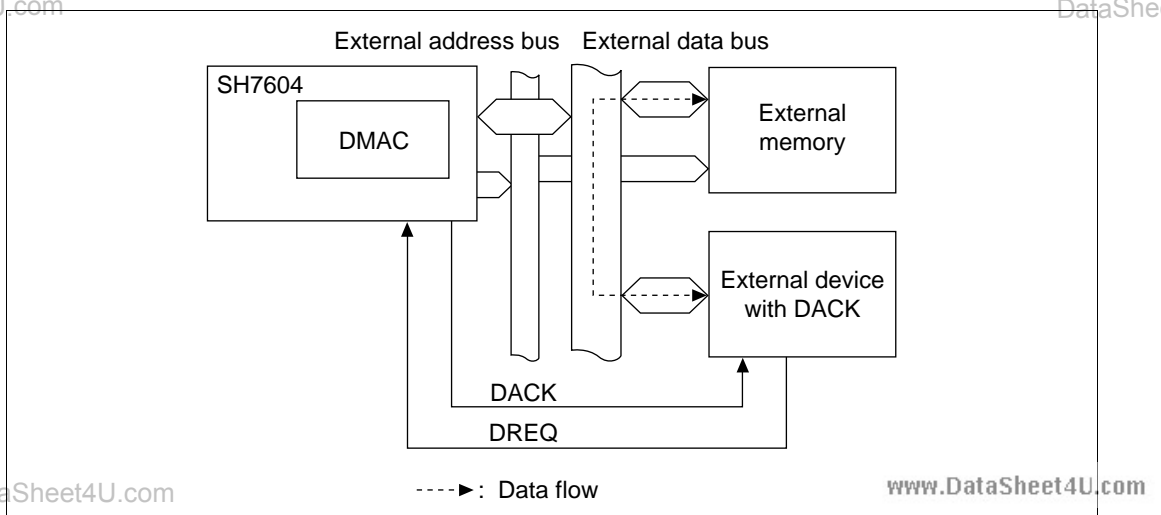

Figure 9.6 Data Flow in Single Address Mode

Two types of transfers are possible in single address mode: 1) transfers between external devices with DACK and memory-mapped external devices; and 2) transfers between external devices with DACK and external memory. Transfer requests for both of these must be by means of the external request signal (DREQ). Figure 9.7 shows the DMA transfer timing for single address mode.

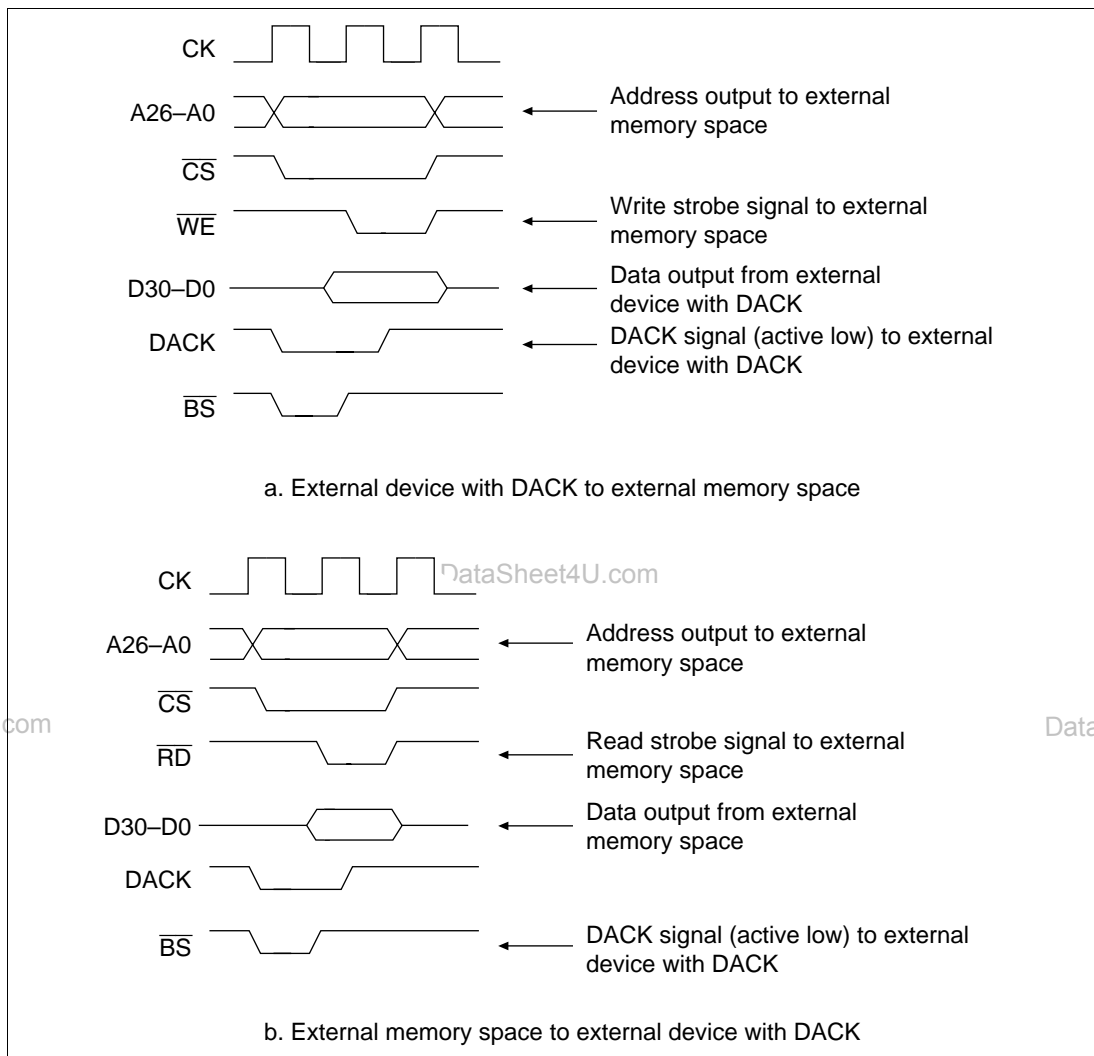

Figure 9.7 DMA Transfer Timing in Single Address Mode

- Dual Address Mode

In dual address mode, both the transfer source and destination are accessed (selectable) by address. The source and destination can be located externally or internally. The DMAC accesses the source in the read cycle and the destination in the write cycle, so the transfer is performed in two separate bus cycles. The transfer data is temporarily stored in the DMAC. Figure 9.8 shows an example of a transfer between two external memories in which data is read from one memory in the read cycle and written to the other memory in the following write cycle.

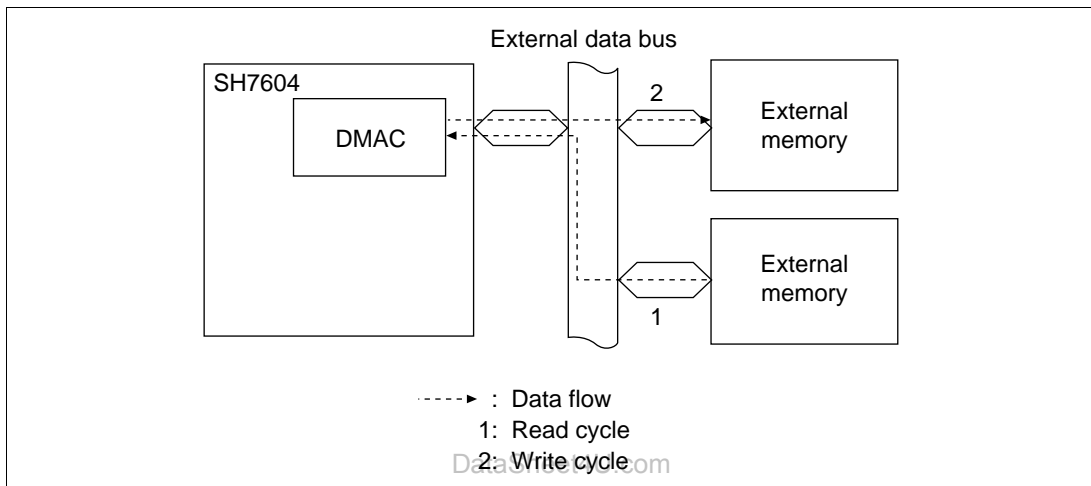

Figure 9.8 Data Flow in Dual Address Mode

In dual address mode transfers, external memory, memory-mapped external devices and on-chip peripheral modules can be mixed without restriction. Specifically, this enables transfers between the following:

1. External memory and external memory.
2. External memory and memory-mapped external devices.
3. Memory-mapped external devices and memory-mapped external devices.
4. External memory and on-chip peripheral modules (excluding the DMAC, BSC, and UBC).
5. Memory-mapped external devices and on-chip peripheral modules (excluding the DMAC, BSC, and UBC). The access size is that is enabled by the register of the on-chip peripheral module that is the source or destination (excludes the DMAC, BSC, and UBC).
6. On-chip peripheral modules (excluding the DMAC, BSC, and UBC) and on-chip peripheral modules (excluding the DMAC, BSC, and UBC).

Transfer requests can be auto-requests, external requests, or on-chip peripheral module requests. When the transfer request source is the SCI, however, either the data destination or source must be the SCI (see table 9.6). Dual address mode outputs DACK in either the read cycle or write cycle. CHCR controls the cycle in which DACK is output.

Figure 9.9 shows the DMA transfer timing in dual address mode.

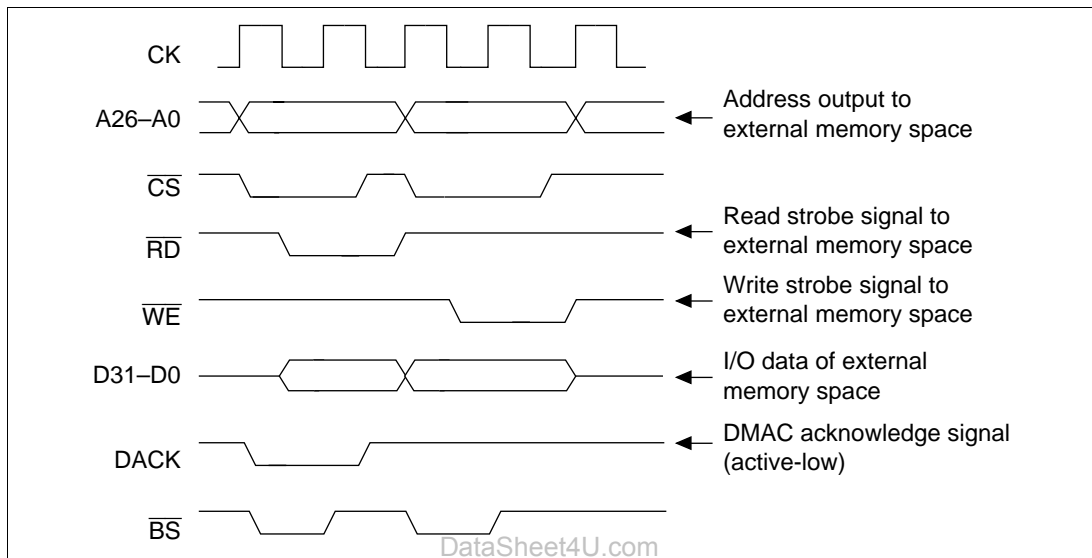

Figure 9.9 DMA Transfer Timing in Dual Address Mode
(External Memory Space → External Memory Space, DACK Output in Read Cycle)

Bus Modes: There are two bus modes: cycle-steal and burst. Select the mode with the TB bits in CHCR0 and CHCR1.

- **Cycle-Steal Mode**

In cycle-steal mode, the bus right is given to another bus master after the DMAC transfers one transfer unit (byte, word, longword, or 16 bytes). When another transfer request occurs, the bus right is retrieved from the other bus master and another transfer is performed for one transfer unit. When that transfer ends, the bus right is passed to the other bus master. This is repeated until the transfer end conditions are satisfied.

Cycle-steal mode can be used with all categories of transfer destination, transfer source, and transfer request source. The CPU may take the bus twice when an acknowledge signal is output during the write cycle or in single address mode. Figure 9.10 shows an example of DMA transfer timing in cycle-steal mode (dual address mode, DREQ level detection).

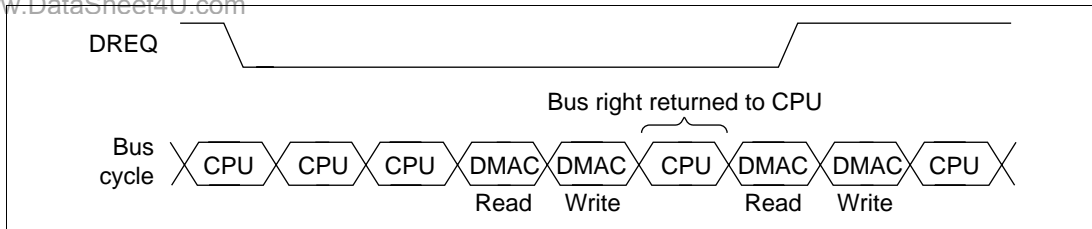

**Figure 9.10 DMA Transfer Timing in Cycle-Steal Mode
(Dual Address Mode, DREQ Level Detection)**

- Burst Mode

In burst mode, once the DMAC gets the bus, the transfer continues until the transfer end condition is satisfied. When external request mode is used with level detection of the DREQ pin, however, negating DREQ will pass the bus to the other bus master after completion of the bus cycle of the DMAC that currently has an acknowledged request, even if the transfer end conditions have not been satisfied. Burst mode cannot be used when the transfer request originates from the serial communication interface (SCI).

Figure 9.11 shows an example of DMA transfer timing in burst mode (single address mode, DREQ level detection).

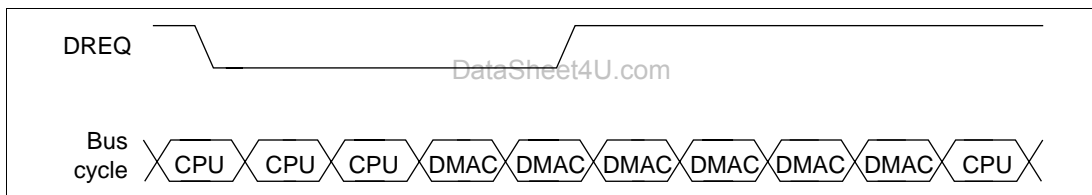

Figure 9.11 DMA Transfer Timing in Burst Mode (Single Address Mode, DREQ Level Detection)

Refreshes cannot be performed during a burst transfer, so ensure that the number of transfers satisfies the refresh request period when a memory requiring refreshing is used.

Relationship of Request Modes and Bus Modes by DMA Transfer Category: Table 9.8 shows the relationship between request modes, bus modes, etc., by DMA transfer category.

Table 9.8 Relationship of Request Modes and Bus Modes by DMA Transfer Category

Address Mode	Transfer Category	Request Mode	Bus Mode	Transfer Size (Bytes)
Single	External device with DACK and external memory	External	B/C	1/2/4
	External device with DACK and memory-mapped external device	External	B/C	1/2/4
Dual	External memory and external memory	All* ¹	B/C	1/2/4/16
	External memory and memory-mapped external device	All* ¹	B/C	1/2/4/16
	Memory-mapped external device and memory-mapped external device	All* ¹	B/C	1/2/4/16
	External memory and on-chip peripheral module	All* ²	B/C* ³	1/2/4/16* ⁴
	Memory-mapped external device and on-chip peripheral module	All* ²	B/C* ³	1/2/4/16* ⁴
	On-chip peripheral module and on-chip peripheral module	All* ²	B/C* ³	1/2/4/16* ⁴

B: Burst, C: Cycle-steal

- Notes:
1. External requests and auto-requests are both available. The SCI cannot be specified as the transfer request source, however, except for on-chip peripheral module requests.
 2. External requests, auto-requests and on-chip peripheral module requests are all available. When the SCI is the transfer request source, however, the transfer destination or transfer source must be the SCI.
 3. If the transfer request source is the SCI, cycle-steal (C) only (DREQ by edge detection, active low).
 4. The access size is that permitted by the register of the on-chip peripheral module that is the transfer destination or source.

Bus Mode and Channel Priority: When a given channel (1) is transferring in burst mode and there is a transfer request to a channel (0) with a higher priority, the transfer of the channel with higher priority (0) will begin immediately. When channel 0 is also operating in the burst mode, the channel 1 transfer will continue as soon as the channel 0 transfer has completely finished. When channel 0 is in cycle-steal mode, channel 1 will begin operating again after channel 0 completes the transfer of one transfer unit, but the bus will then switch between the two in the order channel 1, channel 0, channel 1, channel 0. Since channel 1 is in burst mode, it will not give the bus to the CPU. This example is illustrated in Figure 9.12.

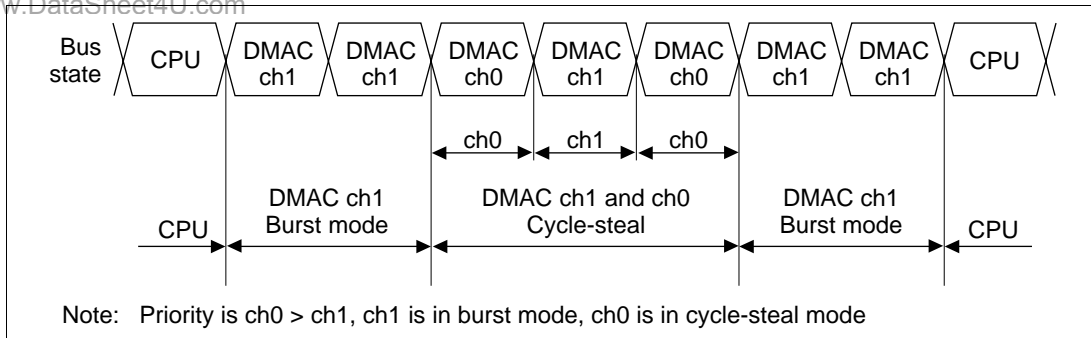

Figure 9.12 Bus Status when Multiple Channels are Operating

9.3.5 Number of Bus Cycles

The number of states in the bus cycle when the DMAC is the bus master is controlled by the bus control register (BCR1) and wait state control register (WCR) of the bus state controller just as it is when the CPU is the bus master.

9.3.6 DMA Transfer Request Acknowledge Signal Output Timing

DMA transfer request acknowledge signal DACK_n is output synchronous to the DMAC address output specified by the channel control AM bit of the address bus. The timing is normally to have the acknowledge signal become valid when the DMA address output begins and become invalid 0.5 cycles before the address output ends. (See figure 9.11.) The output timing of the acknowledge signal varies with the settings of the connected memory space. The output timing of acknowledge signals in the memory spaces is shown in figure 9.13.

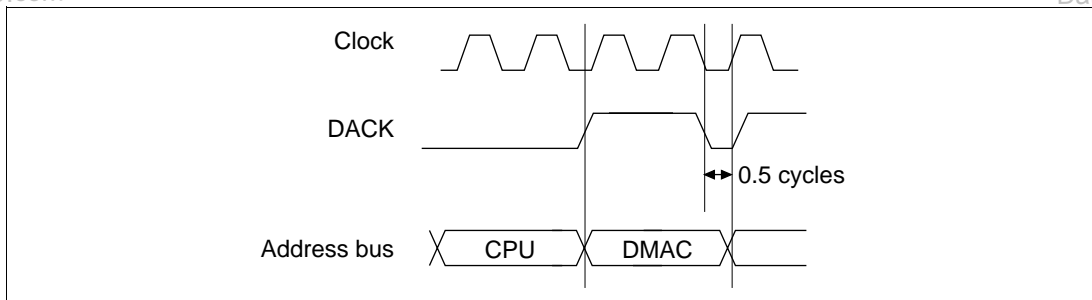

Figure 9.13 Example of DACK Output Timing

Acknowledge Signal Output when External Memory Is Set as Ordinary Memory Space: The timing at which the acknowledge signal is output is the same in the DMA read and write cycles specified by the AM bit (figures 9.14 and 9.15). When DMA address output begins, the acknowledge signal becomes valid; 0.5 cycles before address output ends, it becomes invalid. If a wait is inserted in this period and address output is extended, the acknowledge signal is also extended.

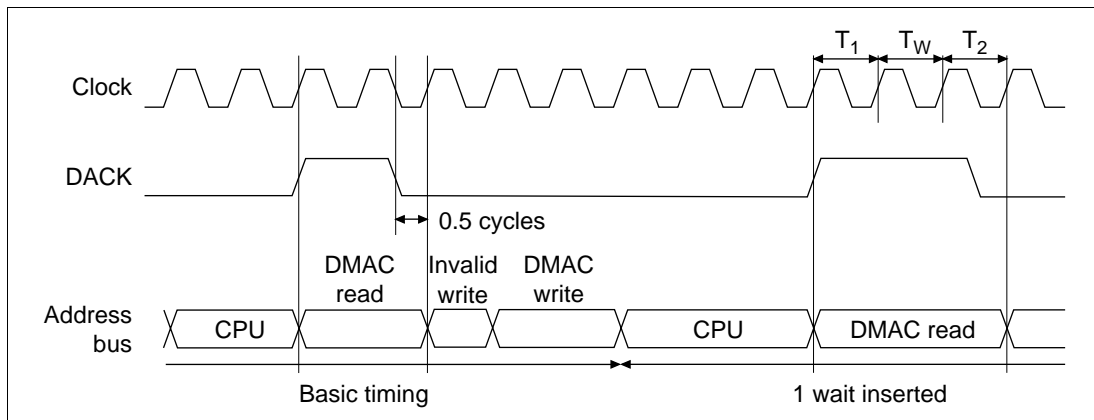

Figure 9.14 DACK Output in Ordinary Space Accesses (AM = 0)

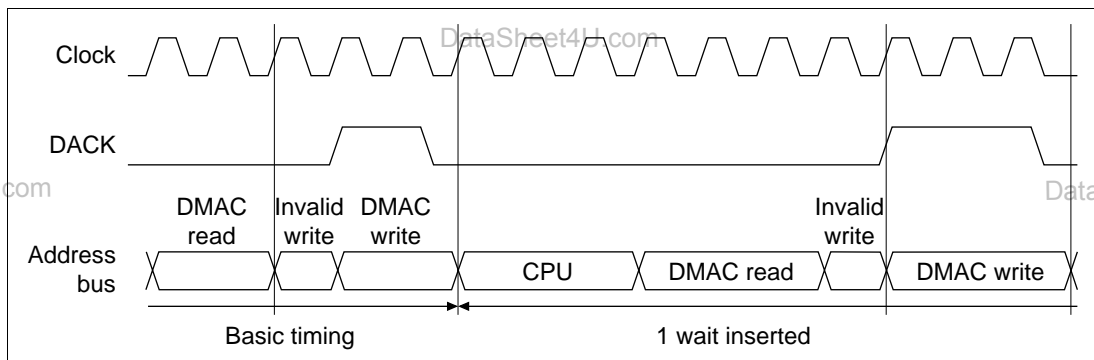
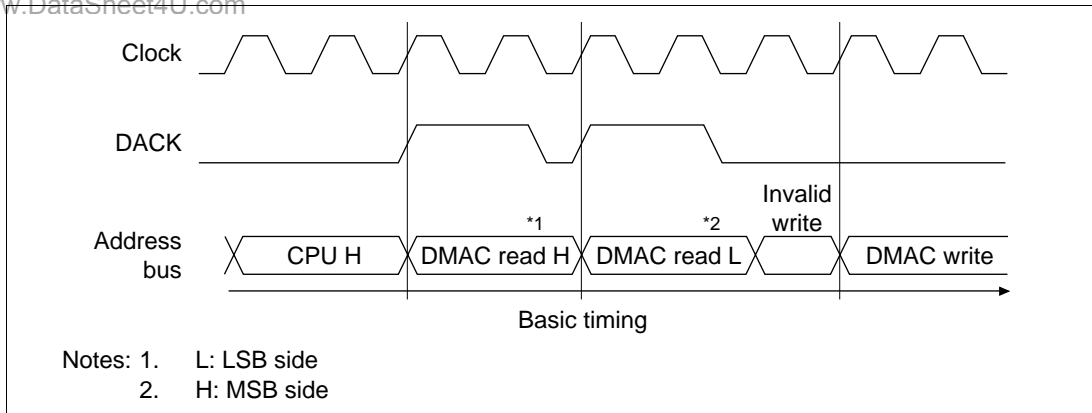
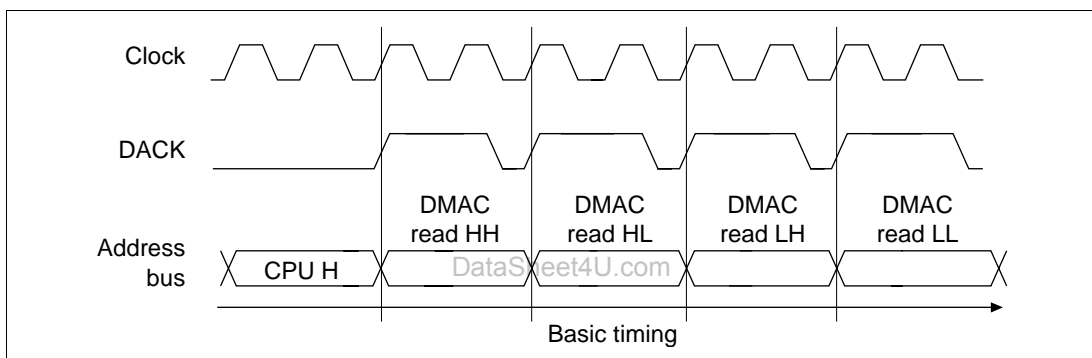

Figure 9.15 DACK Output in Ordinary Space Accesses (AM = 1)

In a longword access of a 16-bit external device (figure 9.16) or an 8-bit external device (figure 9.17), or a word access of an 8-bit external device (figure 9.18), the lower and upper addresses are output 2 and 4 times in each DMAC access in order to align the data. For all of these addresses, the acknowledge signal becomes valid simultaneous with the start of output and becomes invalid 0.5 cycles before the address output ends. When multiple addresses are output in a single access to align data for synchronous DRAM, DRAM, pseudo-SRAM, or burst ROM, an acknowledge signal is output to those addresses as well.



**Figure 9.16 DACK Output in Ordinary Space Accesses
(AM = 0, Longword Access to 16-Bit External Device)**



**Figure 9.17 DACK Output in Ordinary Space Accesses
(AM = 0, Longword Access to 8-Bit External Device)**

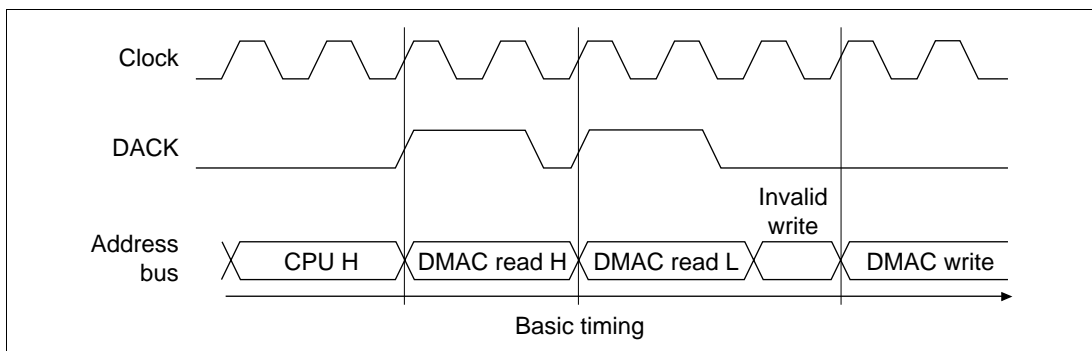

**Figure 9.18 DACK Output in Ordinary Space Accesses
(AM = 0, Word Access to 8-Bit External Device)**

Acknowledge Signal Output when External Memory Is Set as Synchronous DRAM: When external memory is set as synchronous DRAM auto-precharge and $AM = 0$, the acknowledge signal is output across the row address, read command, wait and read address of the DMAC read (figure 9.19). Since the synchronous DRAM read has only burst mode, during a single read an invalid address is output; the acknowledge signal, however, is output on the same timing (figure 9.20). At this time, the acknowledge signal is extended until the write address is output after the invalid read. When $AM = 1$, the acknowledge signal is output across the row address and column address of the DMAC write (figure 9.21).

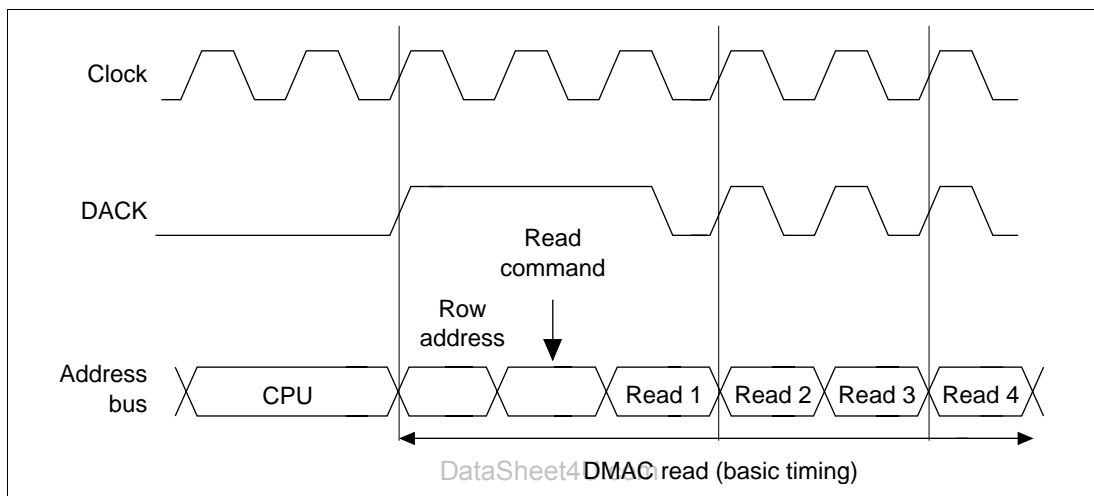

Figure 9.19 DACK Output in Synchronous DRAM Burst Read (Auto-Precharge, $AM = 0$)

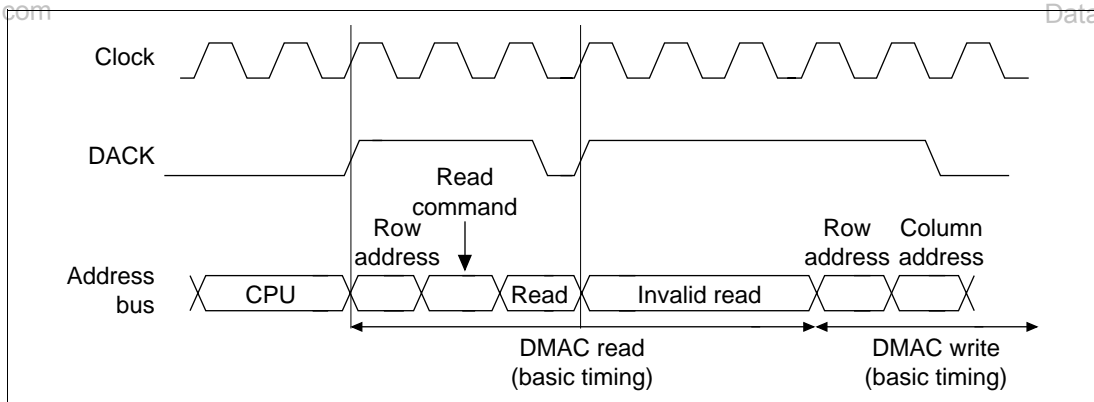

Figure 9.20 DACK Output in Synchronous DRAM Single Read (Auto-Precharge, $AM = 0$)

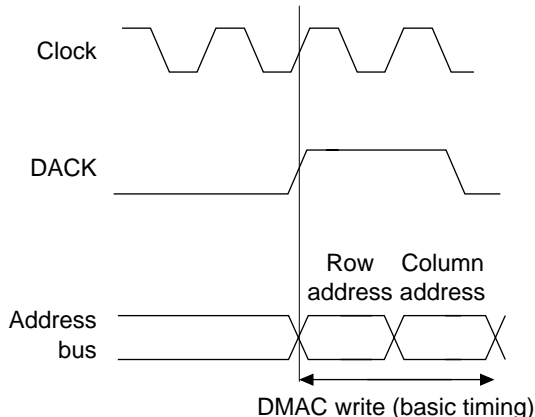

Figure 9.21 DACK Output in Synchronous DRAM Write (Auto-Precharge, AM = 1)

When external memory is set as bank active synchronous DRAM, during a burst read the acknowledge signal is output across the read command, wait and read address when the row address is the same as the previous address output (figure 9.22). When the row address is different from the previous address, the acknowledge signal is output across the precharge, row address, read command, wait and read address (figure 9.23).

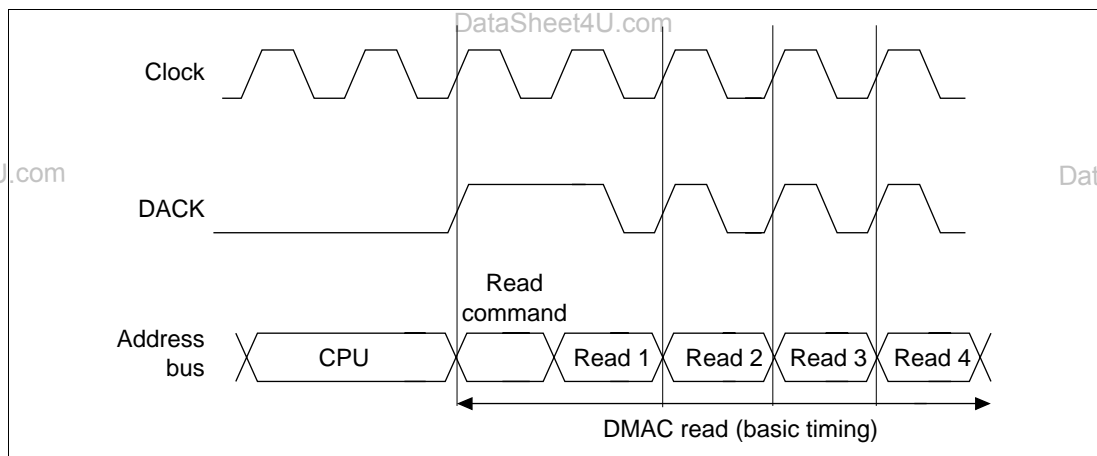
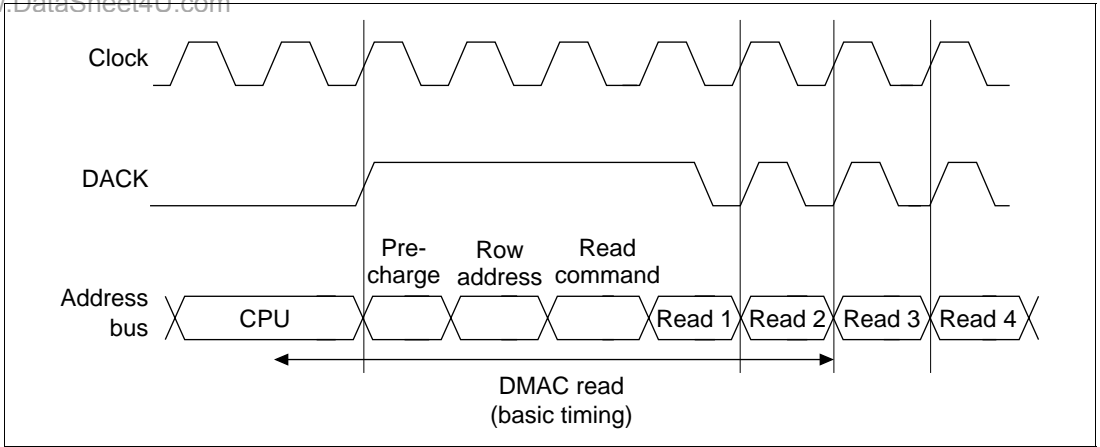
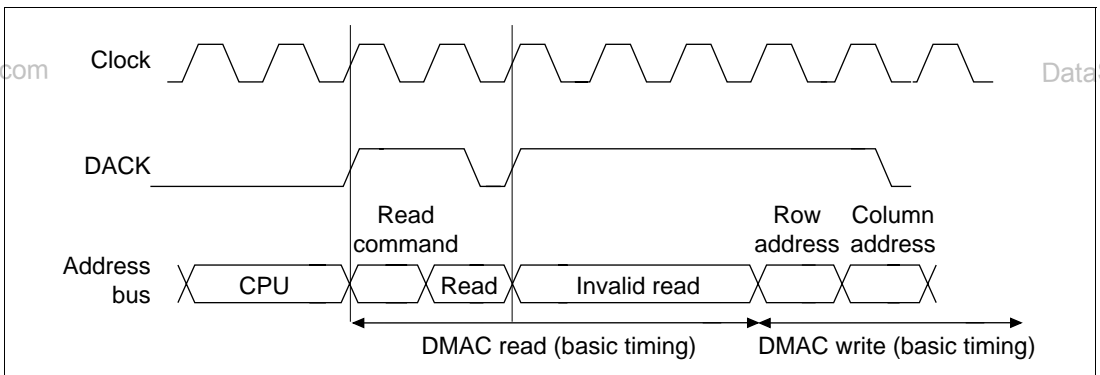

Figure 9.22 DACK Output in Synchronous DRAM Burst Read (Bank Active, Same Row Address, AM = 0)

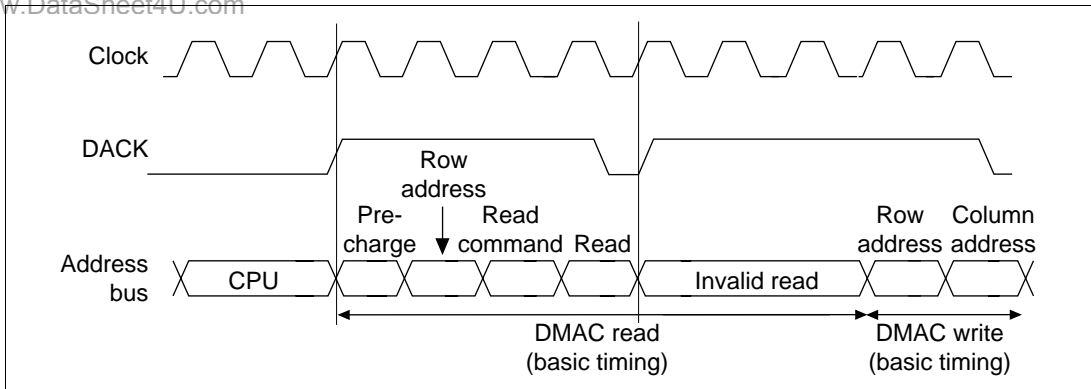

**Figure 9.23 DACK Output in Synchronous DRAM Burst Read
(Bank Active, Different Row Address, AM = 0)**

When external memory is set as bank active synchronous DRAM, during a single read the acknowledge signal is output across the read command, wait and read address when the row address is the same as the previous address output (figure 9.24). When the row address is different from the previous address, the acknowledge signal is output across the precharge, row address, read command, wait and read address (figure 9.25). Since the synchronous DRAM read has only burst mode, during a single read an invalid address is output; the acknowledge signal is output on the same timing. At this time, the acknowledge signal is extended until the write address is output after the invalid read.

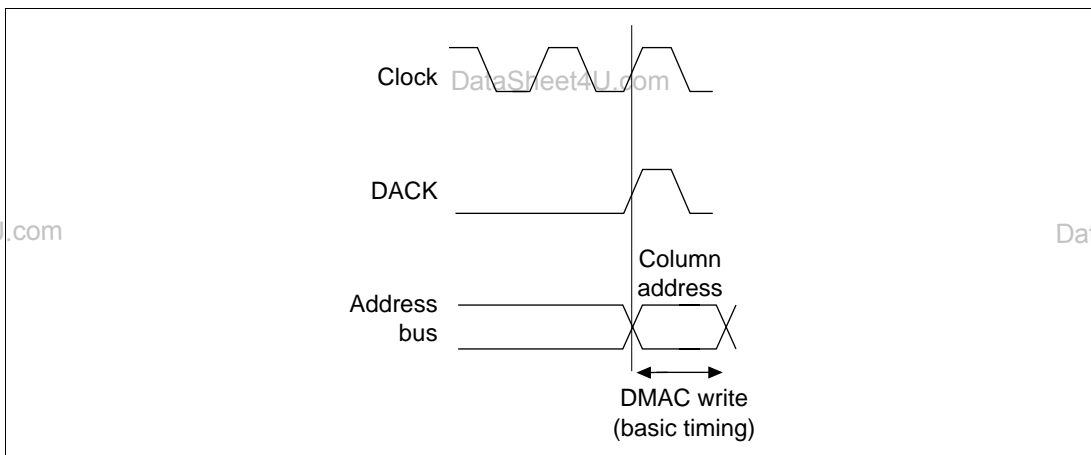

**Figure 9.24 DACK Output in Synchronous DRAM Single Read
(Bank Active, Same Row Address, AM = 0)**

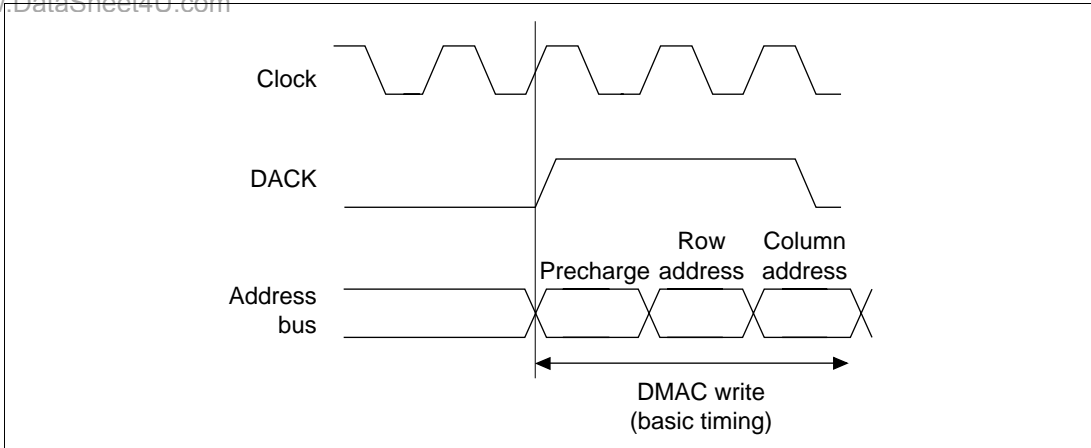

**Figure 9.25 DACK Output in Synchronous DRAM Single Read
(Bank Active, Different Row Address, AM = 0)**

When external memory is set as bank active synchronous DRAM, during a write the acknowledge signal is output across the wait and column address when the row address is the same as the previous address output (figure 9.26). When the row address is different from the previous address, the acknowledge signal is output across the precharge, row address, wait and column address (figure 9.27).



**Figure 9.26 DACK Output in Synchronous DRAM Write
(Bank Active, Same Row Address, AM = 1)**



**Figure 9.27 DACK Output in Synchronous DRAM Write
(Bank Active, Different Row Address, AM = 1)**

Acknowledge Signal Output when External Memory Is Set as DRAM: When external memory is set as DRAM and a row address is output during a read or write, the acknowledge signal is output across the row address and column address (figures 9.28–9.30).

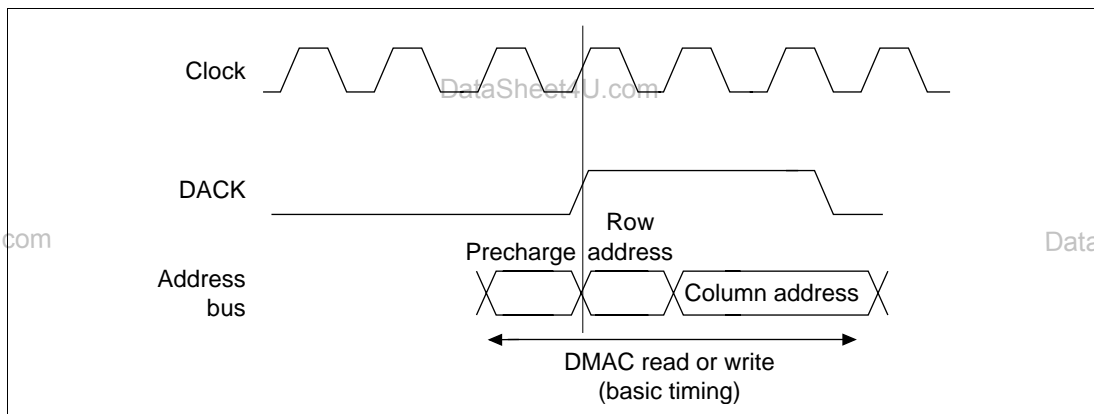
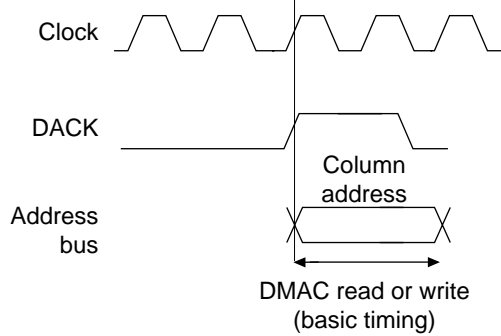
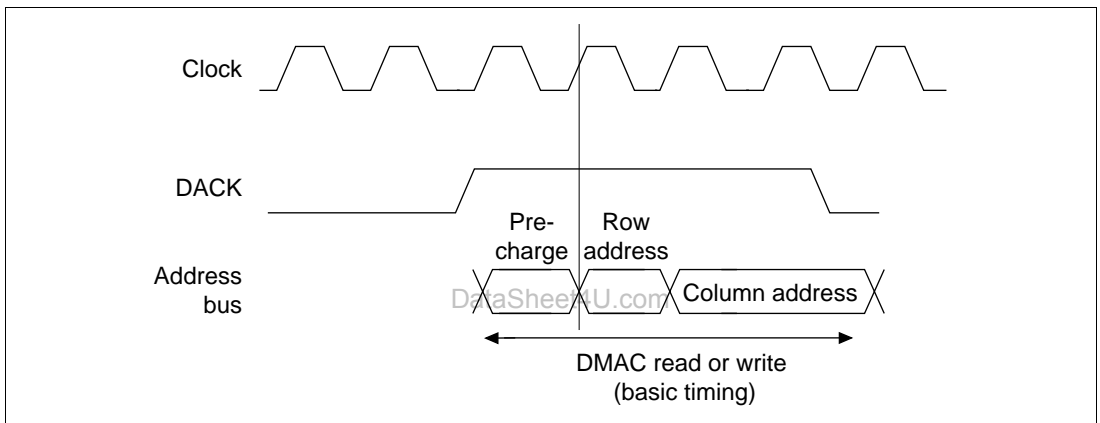

Figure 9.28 DACK Output in Normal DRAM Accesses (AM = 1 or 0)



**Figure 9.29 DACK Output in DRAM Burst Accesses
(Same Row Address, AM = 1 or 0)**



**Figure 9.30 DACK Output in DRAM Burst Accesses
(Different Row Address, AM = 1 or 0)**

Acknowledge Signal Output when External Memory Is Set as Pseudo-SRAM: When external memory is set as pseudo-SRAM, the acknowledge signal is output synchronous to the DMAC address for both reads and writes (figures 9.31–9.33).

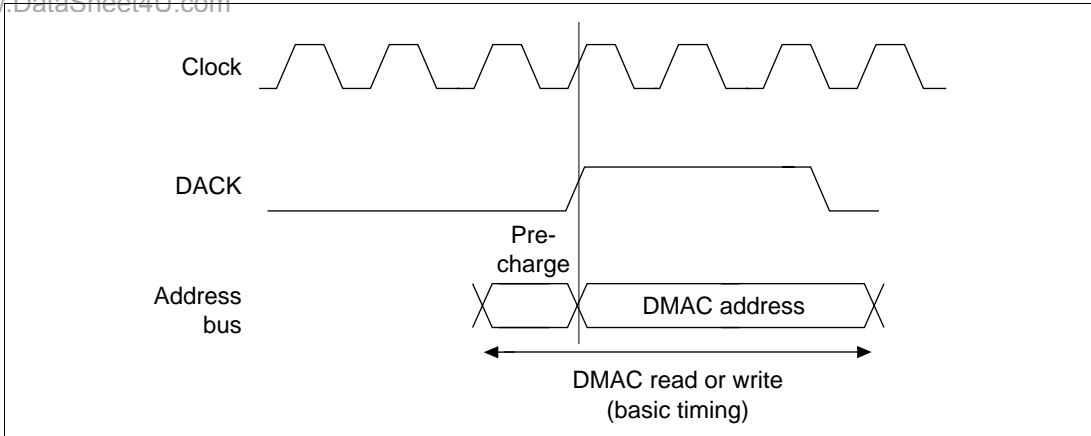

Figure 9.31 DACK Output in Normal Pseudo-SRAM Accesses (AM = 1 or 0)

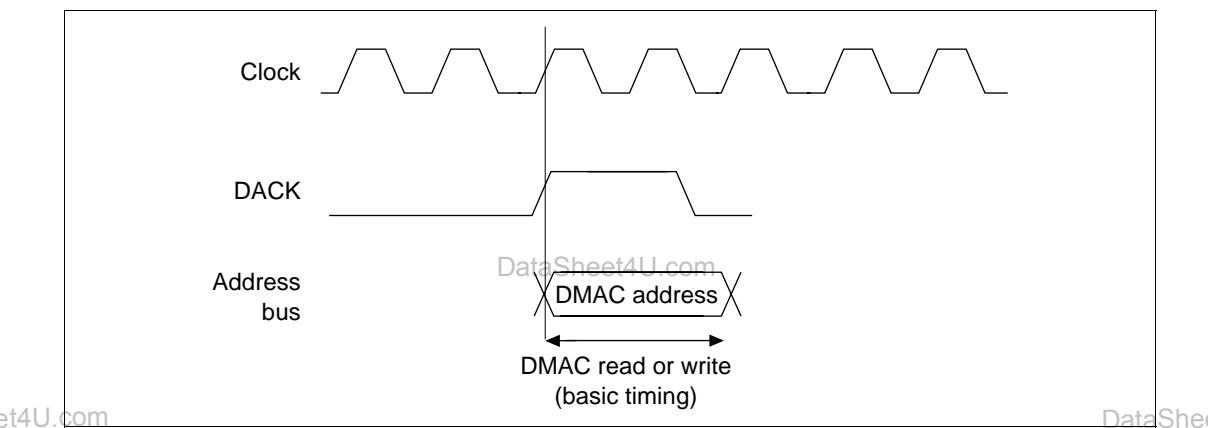

Figure 9.32 DACK Output in Pseudo-SRAM Burst Accesses (Same Row Address, AM = 1 or 0)

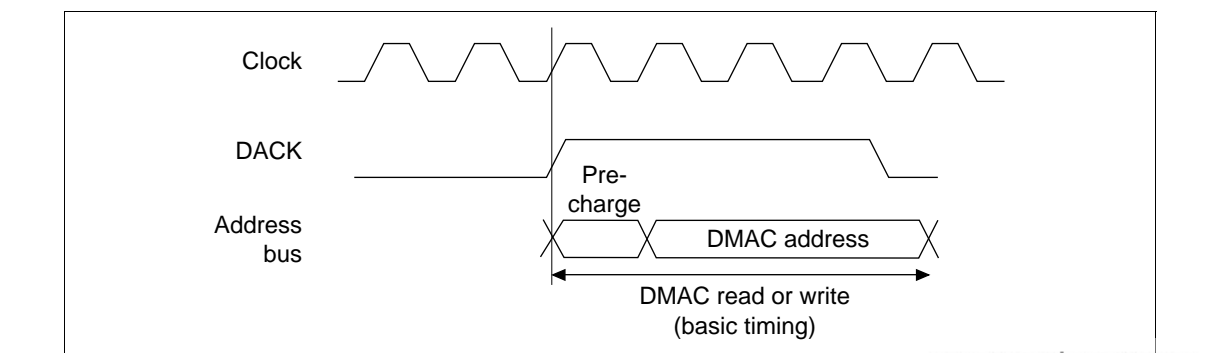

Figure 9.33 DACK Output in Pseudo-SRAM Burst Accesses (Different Row Address, AM = 1 or 0)

Acknowledge Signal Output When External Memory Is Set as Burst ROM: When external memory is set as burst ROM, the acknowledge signal is output synchronous to the DMAC address (no dual writes allowed) (figure 9.34).

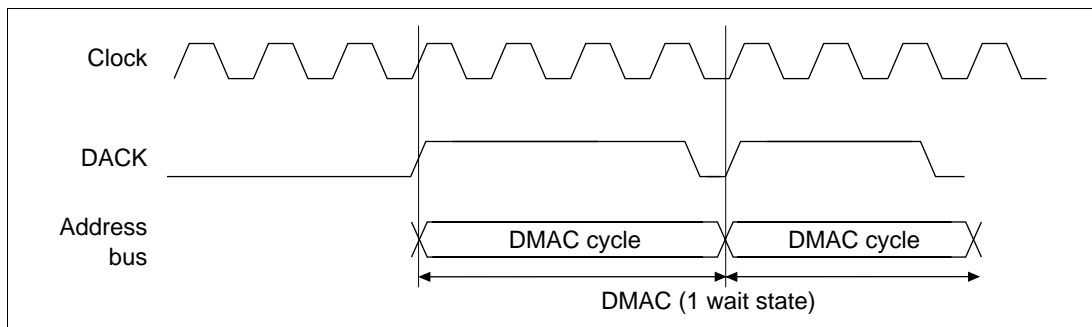

Figure 9.34 DACK Output in Nibble Accesses of Burst ROM

9.3.7 DREQ Pin Input Detection Timing

In external request mode, DREQ pin signals are usually detected at the rising edge of the clock pulse (CKIO). When a request is detected, a DMAC bus cycle is produced three cycles later at the earliest and a DMA transfer performed. After the request is detected, the timing of the next input detection varies with the bus mode, address mode, method of DREQ input detection, and the memory connected.

DataSheet4U.com

DREQ Pin Input Detection Timing in Cycle-Steal Mode:

In cycle-steal mode, once a request is detected from the DREQ pin, request detection for the next DMA transfer cannot be performed for a certain period of time. After request detection has again become possible, detectable cycles continue until a request is detected.

Figure 9.35 illustrates the timing from the detection of a request till the next time requests are detectable.

- Cycle-Steal Mode Edge Detection

Requests can be detected 2 cycles after DACK output. After that point, the request is input to DREQ. (If input prior to that point, a request may or may not be detected, depending on the internal state.)

Transfer width: Byte, word, longword
 Transfer bus mode: Cycle-steal mode
 Transfer address modes: Dual and single modes
 DREQ detection method: Edge detection
 DACK output timing: Read, write (dual), DMAC cycle (single)
 Bus cycle: Basic bus cycle

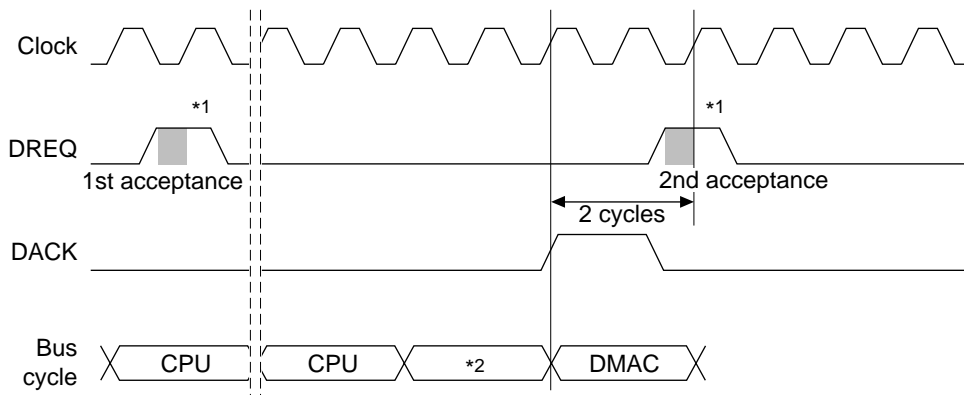

- Notes:
1. Request detection
 2. When DACK is output in a write (dual), the cycle is a DMAC read. Otherwise, the cycle is a CPU cycle.

Figure 9.35 DREQ Pin Input Detection Timing in Cycle-Steal Mode with Edge Detection (1)

Figures 9.36 and 9.37 show examples of how to change the bus width of an external device.

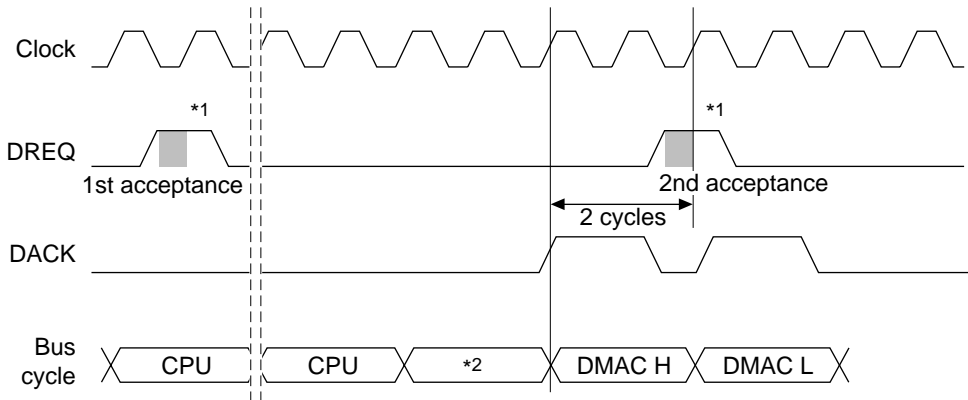

Notes: 1. Request detection

2. When DACK is output in a write (dual), the cycle is a DMAC read. Otherwise, the cycle is a CPU cycle.

Figure 9.36 Changing the Bus Size of a 16-Bit External Device

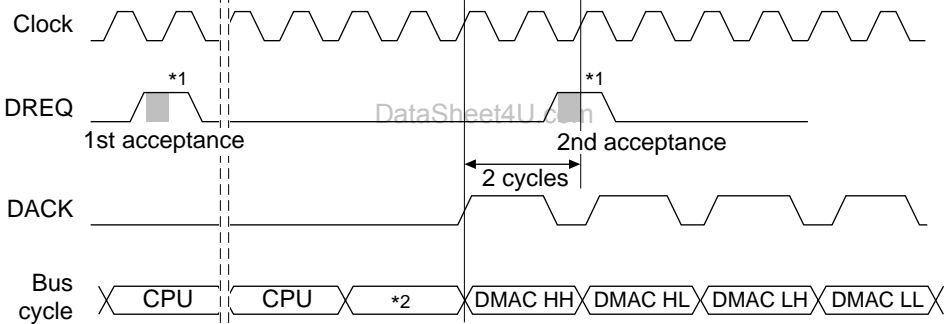

Notes: 1. Request detection

2. When DACK is output in a write (dual), the cycle is a DMAC read. Otherwise, the cycle is a CPU cycle.

Figure 9.37 Changing the Bus Size of an 8-Bit External Device

Transfer width: 16-byte
 Transfer bus mode: Cycle-steal mode
 Transfer address mode: Dual mode
 DREQ detection method: Edge detection
 DACK output timing: DMAC read and write cycles
 Bus cycle: Basic bus cycle

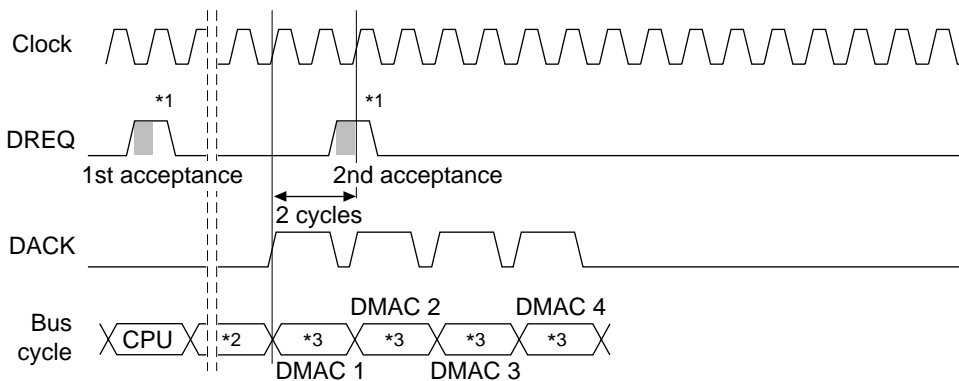

- Notes
1. Request detection
 2. When a write (dual) occurs at DACK output, the cycle is a DMAC read. Otherwise, the cycle is a CPU cycle.
 3. When DACK is output in a write (dual), the cycle is a DMAC write; when in a read (dual), the cycle is a DMAC read.

Figure 9.38 DREQ Pin Input Detection Timing in Cycle-Steal Mode with Edge Detection (2)

Requests can be detected 2 cycles after DACK output. After that point, the request is input to DREQ. (If input prior to that point, a request may or may not be detected, depending on the internal state.) DACK is output synchronous to all 4 transfers (figure 9.38).

Transfer width: Byte, word, longword
 Transfer bus mode: Cycle-steal mode
 Transfer address modes: Dual and single modes
 DREQ detection method: Level detection
 DACK output timing: Read (dual), DMAC cycle (single)
 Bus cycle: Basic bus cycle

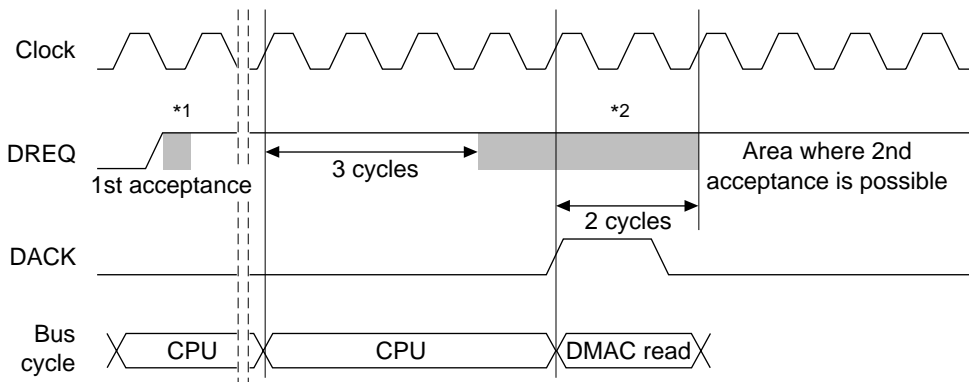

Notes: 1. Request detection
 2. Request detection not established.

Figure 9.39 Timing of DREQ Pin Input Detection in Cycle-Steal Mode with Level Detection (1)

- Cycle-Steal Mode Level Detection

Requests can be detected for the first time 3 cycles after the bus cycle prior to the DMAC read cycle and detection starts sometime between then and 2 cycles after DACK output (figure 9.40, 41). This varies with variations in waits and the like. This means that if request output is stopped within 3 cycles from the bus cycle prior to the DMAC read cycle, the next DMA transfer is not performed; if request output is stopped within 2 cycles of DACK output, the next DMA transfer may sometimes be performed. See Examples of Handling of Request Signal Acceptance later in this section (9.3.7).

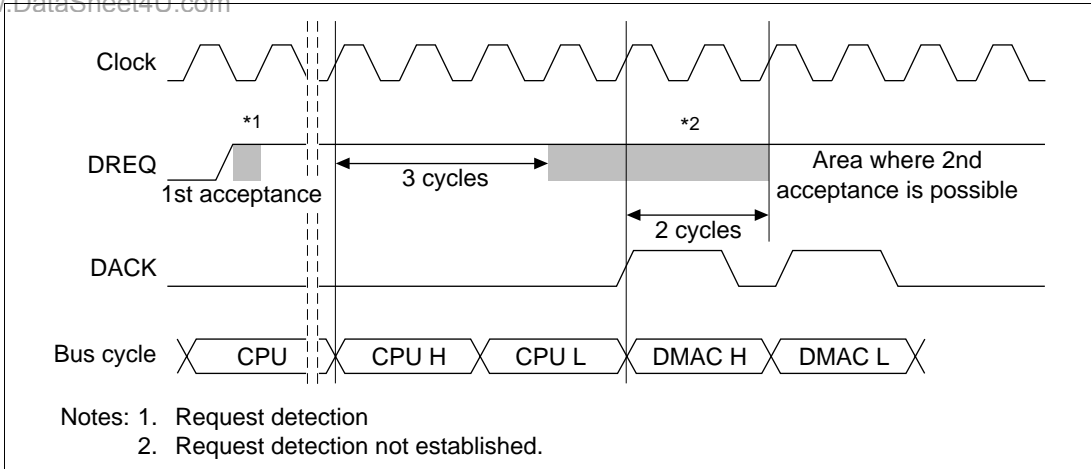

Figure 9.40 Changing the Bus Size of a 16-Bit External Device

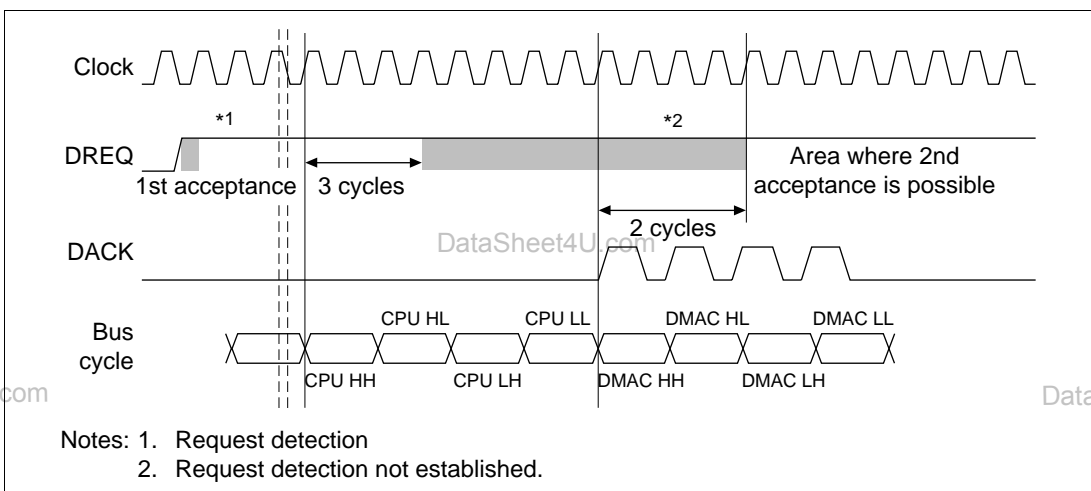
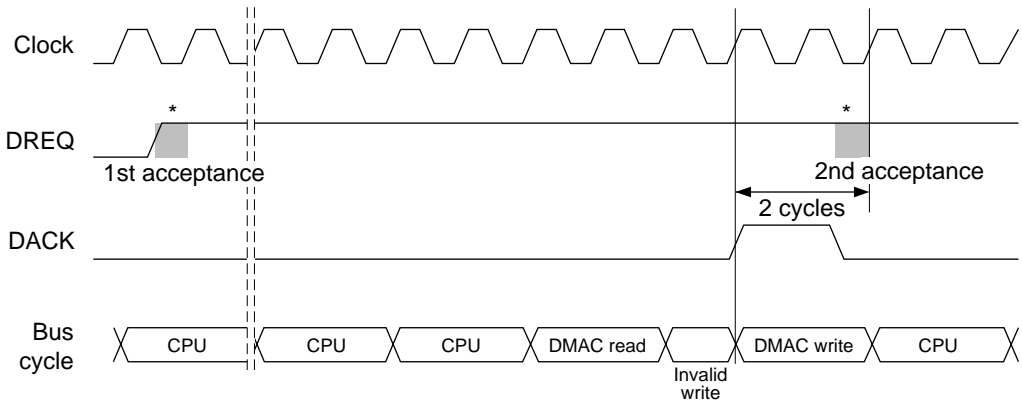

Figure 9.41 Changing the Bus Size of an 8-Bit External Device

Transfer width: Byte, word, longword
 Transfer bus mode: Cycle-steal mode
 Transfer address mode: Dual mode
 DREQ detection method: Level detection
 DACK output timing: DMAC write cycle
 Bus cycle: Basic bus cycle



Note: Request detection

Figure 9.42 Timing of DREQ Pin Input Detection in Cycle Steal Mode with Level Detection (2)

The next request can be detected 2 cycles after DACK output (figure 9.42).

Transfer width: 16-byte
 Transfer bus mode: Cycle-steal mode
 Transfer address mode: Dual mode
 DREQ detection method: Level detection
 DACK output timing: DMAC write cycle
 Bus cycle: Basic bus cycle

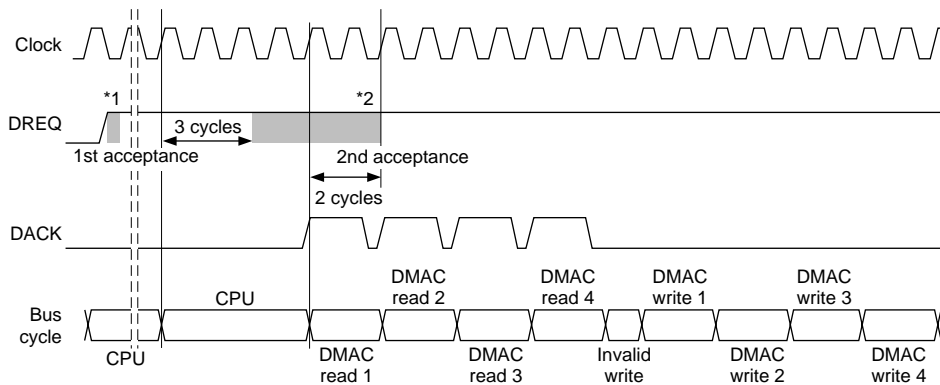

- Notes: 1. Request detection
 2. Request detection not established.

Figure 9.43 Timing of DREQ Pin Input Detection in Cycle Steal Mode with Level Detection (3)

Requests can be detected for the first time 3 cycles after the bus cycle prior to the DMAC read cycle and starts sometime between then and 2 cycles after DACK output (figure 9.43). This varies with variations in waits and the like. This means that if request output is stopped within 3 cycles from the bus cycle prior to the DMAC read cycle, the next DMA transfer is not performed; if request output is stopped within 2 cycles of DACK output, the next DMA transfer may sometimes be performed.

Transfer width: 16-byte
 Transfer bus mode: Cycle-steal mode
 Transfer address mode: Dual mode
 DREQ detection method: Level detection
 DACK output timing: DMAC write cycle
 Bus cycle: Basic bus cycle

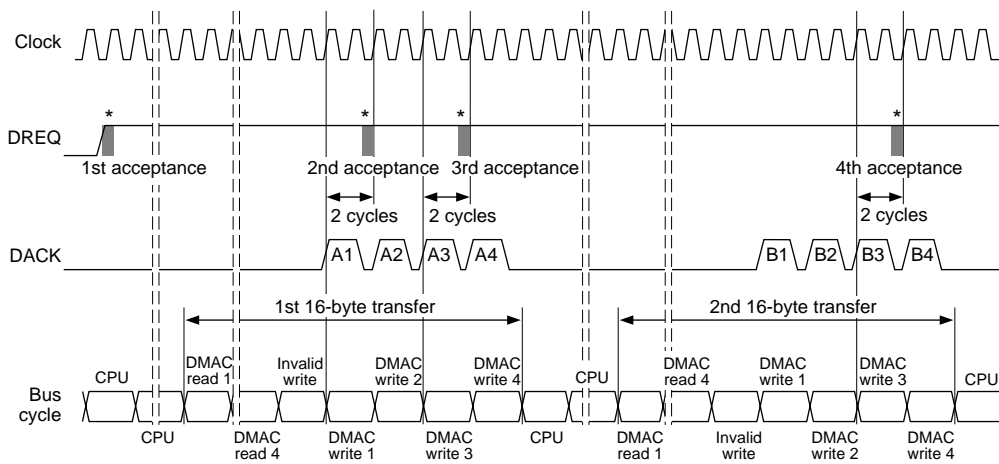

Note: Request detection

Figure 9.44 Timing of DREQ Pin Input Detection in Cycle Steal Mode with Level Detection (4)

For 16-byte transfers, DACK signals are output at all consecutive writes (figure 9.44). The acknowledge signals are A1, A2, A3, A4, B1, B2, B3, B4,

The second transfer request can be detected 2 cycles after output of acknowledge signal A1. The third transfer request is detected at A3, that is, 2 cycles after output of the third acknowledge signal of the first transfer. The fourth transfer request is detected 2 cycles after output of B3. Requests thereafter are detected 2 cycles after the third acknowledge signal of each transfer, as with the fourth transfer.

Note: When transferring alternately on channels 0 and 1 by round robin or the like, the next request signal is detected only 2 cycles after the first acknowledge signal of each transfer (figure 9.45).

Transfer width: 16-byte
 Transfer bus mode: Cycle-steal mode
 Transfer address mode: Dual mode
 Priority mode: Round robin mode

DREQ detection method: Level detection
 DACK output timing: DMAC write cycle
 Bus cycle: Basic bus cycle

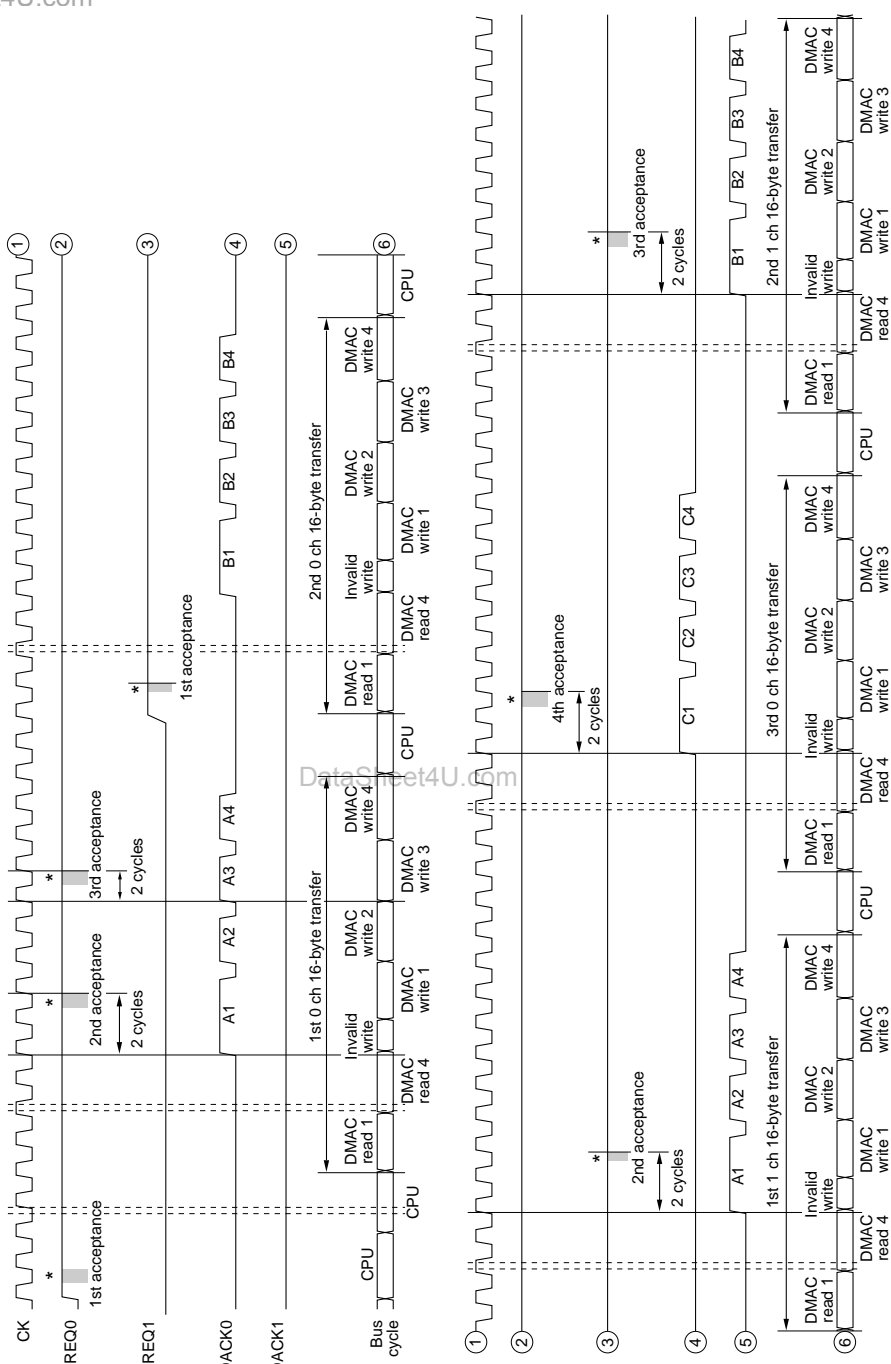

Note: Request detection timing

Figure 9.45 Example of Simultaneous Operation of 2 Channels

DREQ Pin Input Detection Timing in Burst Mode: In burst mode, the request detection timing differs when DREQ input is detected by edge and when detected by level.

When DREQ input is detected by edge, once a request is detected, DMA transfers continue until the conditions for ending the transfers are met, regardless of the state of the DREQ pin thereafter. During this period, requests cannot be detected. When the transfer start conditions are met after a transfer ends, requests can be detected again for each cycle.

When DREQ input is detected by level, whenever a request is detected for the same channel as in the next request detection cycle, that channel is executed continuously. When no request is input, however, the bus cycles of other channels and other bus masters are executed.

- Burst Mode, Single Mode, Level Detection

Acknowledge signals for request signals are output 3 cycles later at the earliest. Even when the request signal is dropped within 2 cycles of the output of this acknowledge signal, the fourth or fifth requests in figure 9.46 are accepted. This means that 4 or 5 DMA transfers are executed even when the request for the 1st acknowledge signal drops out.

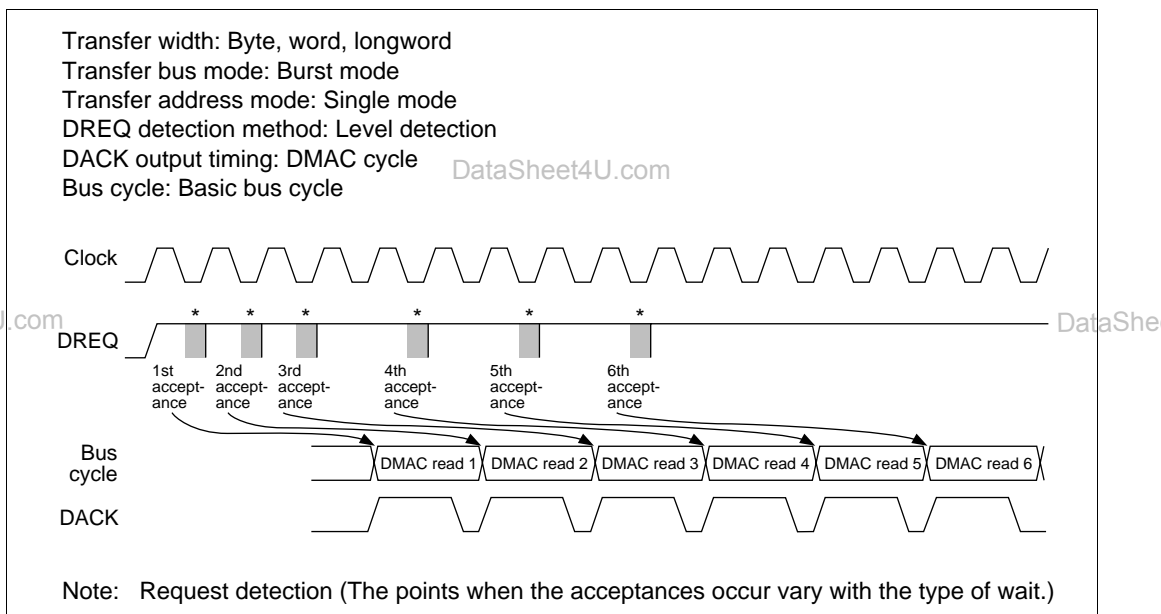
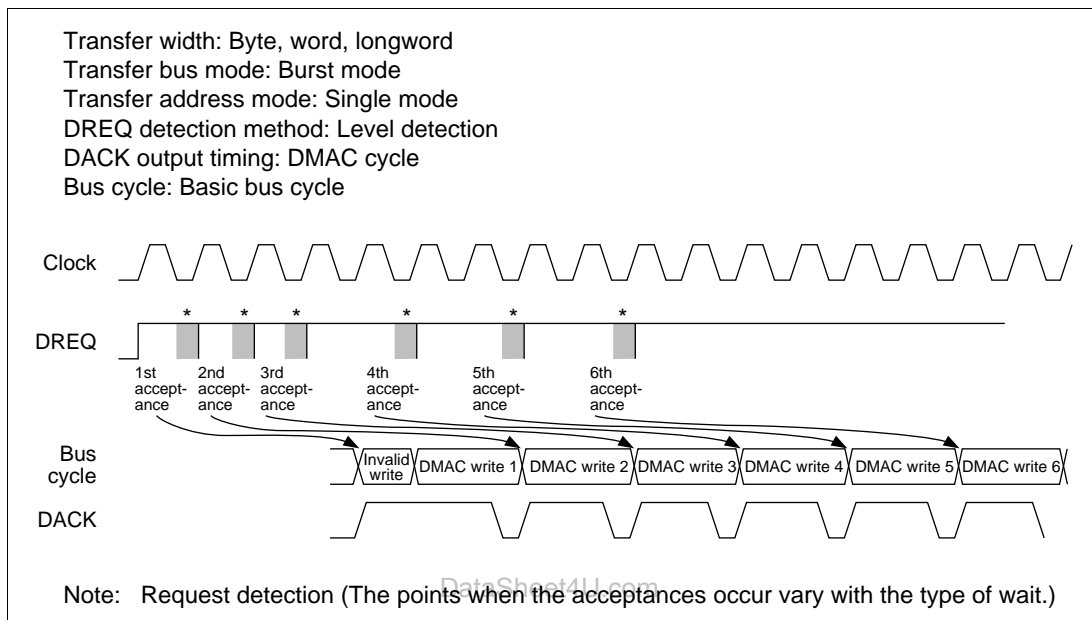

Figure 9.46 Timing of DREQ Pin Input Detection in Burst Mode with Level Detection (1)
 (Data Transfer from Normal Space to Device)

Acknowledge signals for request signals are output 4 cycles later at the soonest. Even when the request signal is dropped within 0.5 cycle of the output of this acknowledge signal, the third request in figure 9.46 is accepted. This means that the 3rd DMA transfer is executed even when the request for the 1st acknowledge signal drops out. The detection timing for the 4th and subsequent requests is as shown in figure 9.46.

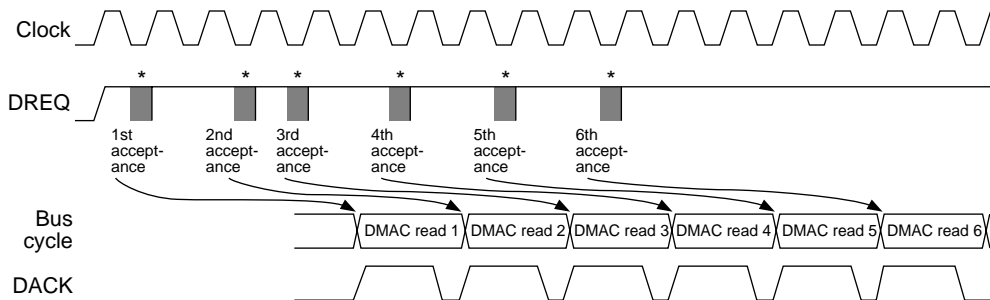

**Figure 9.47 Timing of DREQ Pin Input Detection in Burst Mode with Level Detection (2)
 (Data Transfer from Device to Normal Space)**

Acknowledge signals for request signals are output 4 cycles later at the earliest. Even when the request signal is dropped within 0.5 cycle of the output of this acknowledge signal, the third request in figure 9.47 is accepted. This means that the 3rd DMA transfer is executed even when the request for the first acknowledge signal drops out. The detection timing for the 4th and subsequent requests is a shown in figure 9.47.

Note on Evaluation Chip: The request signal detection timing in the evaluation chip differs from that in the user chip. The evaluation chip detection timing corresponding to figures 9.46 and 9.47 is shown in figures 9.48 and 9.49.

Transfer width: Byte, word, longword
 Transfer bus mode: Burst mode
 Transfer address mode: Single mode
 DREQ detection method: Level detection
 DACK output timing: DMAC cycle
 Bus cycle: Basic bus cycle



Note: Request detection (The points when the acceptances occur vary with the type of wait.)

**Figure 9.48 Timing of DREQ Pin Input Detection in Burst Mode with Level Detection (3)
 (Data Transfer from Normal Space to Device, Using Evaluation Chip)**

Transfer width: Byte, word, longword
 Transfer bus mode: Burst mode
 Transfer address mode: Single mode
 DREQ detection method: Level detection
 DACK output timing: DMAC cycle
 Bus cycle: Basic bus cycle

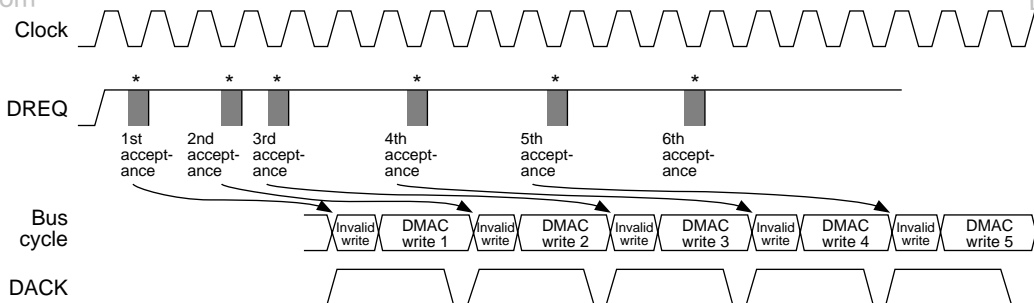

Note: Request detection (The points when the acceptances occur vary with the type of wait.)

**Figure 9.49 Timing of DREQ Pin Input Detection in Burst Mode with Level Detection (4)
 (Data Transfer from Device to Normal Memory, Using Evaluation Chip)**

- Burst Mode, Dual Mode, Level Detection

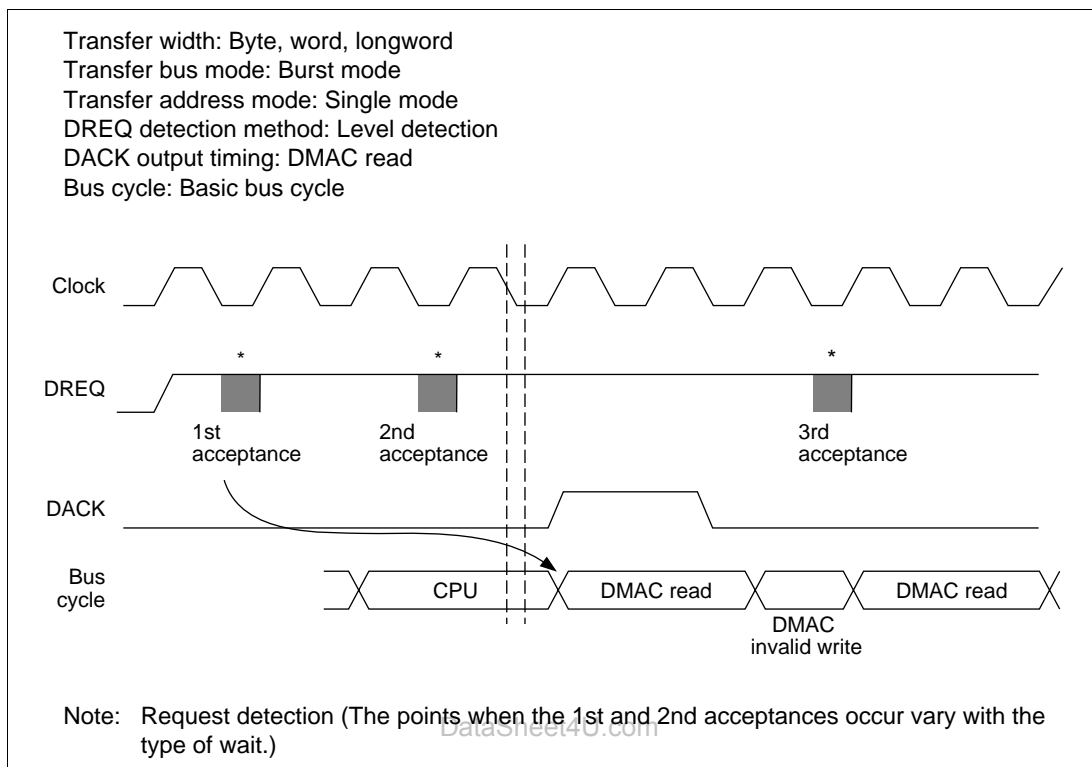
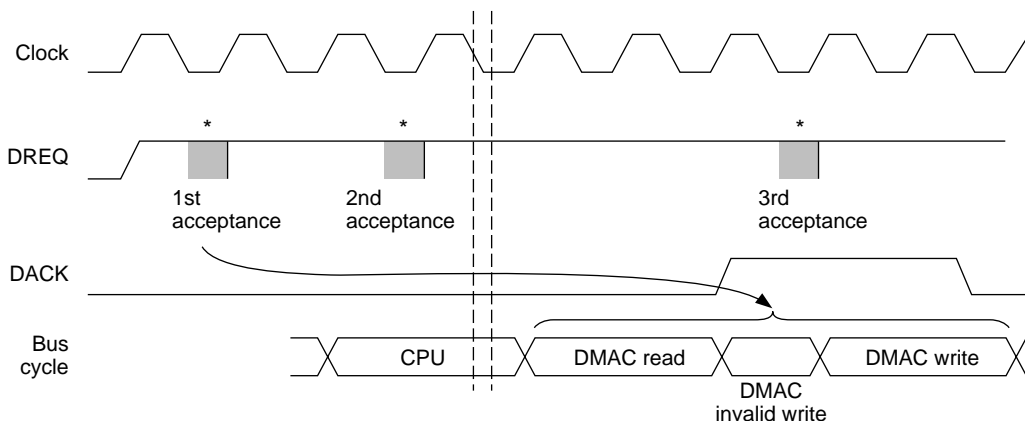

Figure 9.50 Timing of DREQ Pin Input Detection in Burst Mode with Level Detection (5)

Acknowledge signals for request signals are output 4 cycles later, at the soonest. Even when the request signal is dropped within 0.5 cycle of the output of the acknowledge signal, the 2nd request in figure 9.50 is accepted. This means that two DMA transfers are executed even when the request for the 1st acknowledge signal drops out.

Transfer width: Byte, word, longword
 Transfer bus mode: Burst mode
 Transfer address mode: Dual mode
 DREQ detection method: Level detection
 DACK output timing: DMAC write
 Bus cycle: Basic bus cycle



Note: Request detection (The points when the 1st and 2nd acceptances occur vary with the type of wait.)

Figure 9.51 Timing of DREQ Pin Input Detection in Burst Mode with Level Detection (6)

Acknowledge signals for request signals are output 6 cycles later, at the soonest. Even when the request signal is dropped within 0.5 cycle of the output of the acknowledge signal, the 2nd request in figure 9.51 is accepted. This means that two DMA transfers are executed even when the request for the 1st acknowledge signal drops out.

Examples of Handling of Request Signal Acceptance: When DREQ level acceptance is used in the cycle-steal mode, the following methods can be used when the request signal is received:

1. Control the number of transfers by TCR
2. Use edge for request acceptance
3. Perform acknowledge signal output at the DMAC write timing

Additional Cautions when Emulators Are Used: When DREQ level acceptance is by an emulator in cycle-steal mode, the timing of request signal acceptance is 2 cycles after the output of the acknowledge signal, so it differs from ordinary specifications. This means that when DMAC operation is emulated, the timing is somewhat different, which may have other ramifications.

9.3.8 DMA Transfer End

The DMA transfer ending conditions vary when channels end individually and when both channels end together.

Conditions for Channels Ending Individually: When either of the following conditions are met, the transfer will end in the relevant channel only:

- The value of the channel's DMA transfer count register (TCR) becomes 0.

When the TCR value becomes 0, the DMA transfer for that channel ends and the transfer-end flag bit (TE) is set in CHCR. If the IE (interrupt enable) bit has already been set, a DMAC interrupt (DEI) request is sent to the CPU. In 16-byte transfer, when the TCR is 3,2,1 during the final transfer, the source address will be output four times, but the destination address will only be output the number of times found in TCR before transfer ends.

- The DE bit of the DMA channel control register (CHCR) is cleared to 0.

When the DMA enable bit (DE) in CHCR is cleared, DMA transfers in the affected channel are halted. The TE bit is not set when this happens.

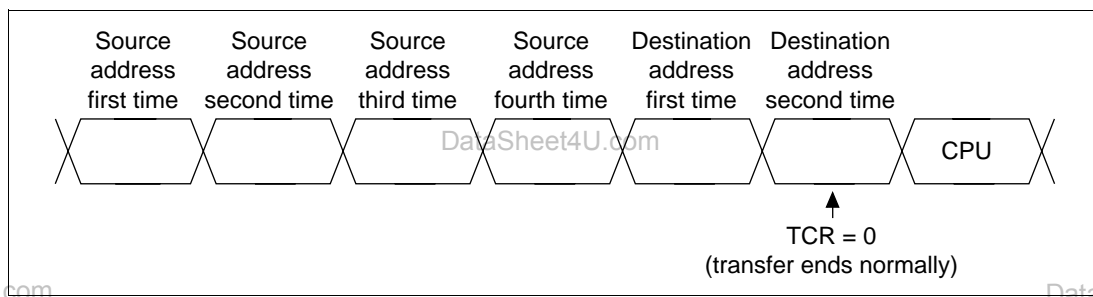

Figure 9.52 16-Byte Transfer when TCR = 2

Conditions for Both Channels Ending Simultaneously: Transfers on both channels end when either of the following conditions is met:

- The NMIF (NMI flag) bit or AE (address error flag) bit is set to 1 in DMAOR.

When an NMI interrupt or DMAC address error occurs and the NMIF or AE bit is set to 1 in DMAOR, all channels stop their transfers. The DMA source address register (SAR), designation address register (DAR), and transfer count register (TCR) are all updated by the transfer immediately preceding the halt. When this transfer is the final transfer, TE = 1 and the transfer ends. To resume transfer after NMI interrupt exception handling or address error exception handling, clear the appropriate flag bit. When the DE bit is then set to 1, the transfer on that channel will restart. To avoid this, keep its DE bit at 0. In dual address mode, DMA transfer will be halted after the completion of the following write cycle even when the address error occurs in the initial read cycle. SAR, DAR and TCR are updated by the final transfer.

- The DMA master enable (DME) bit in DMAOR is cleared to 0.

Clearing the DME bit in DMAOR forcibly aborts the transfers on both channels at the end of the current bus cycle. When the transfer is the final transfer, TE = 1 and the transfer ends.

9.4 Examples of Use

9.4.1 DMA Transfer Between On-Chip SCI and External Memory

In the following example, data received on the on-chip serial communication interface (SCI) is transferred to external memory using DMAC channel 1. Table 9.9 shows the transfer conditions and register settings.

Table 9.9 Register Settings for Transfers between On-Chip SCI and External Memory

Transfer Conditions	Register	Setting
Transfer source: RDR of on-chip SCI	SAR1	H'FFFFFFE05
Transfer destination: external memory (word space)	DAR1	Destination address
Number of transfers: 64	TCR1	H'0040
Transfer destination address: incremented	CHCR1	H'4045
Transfer source address: fixed		
Bus mode: cycle-steal		
Transfer unit: byte		
DEI interrupt request generated at end of transfer (DE = 1)		
Channel priority: Fixed (0 > 1) (DME = 1)	DMAOR	H'0001
Transfer request source (transfer request signal): SCI (RXI)	DRCR1	H'01

Note: Check the CPU interrupt level when interrupts are enabled in the SCI.

9.5 Usage Notes

1. DMA request/response selection control registers 0 and 1 (DRCR0 and DRCR1) should be accessed in bytes. All other registers should be accessed in longword units.
2. Before rewriting CHCR0, CHCR1, DRCR0, and DRCR1, first clear the DE bit for the specified channel to 0 or clear the DME bit in DMAOR to 0.
3. When the DMAC is not operating, the NMIF bit in DMAOR is set even when an NMI interrupt is input.
4. When the cache is used as on-chip RAM, the DMAC cannot access this RAM.
5. Set to standby mode after the DME bit in DMAOR is set to 0.
6. Do not access the DMAC, BSC, and UBC on-chip peripheral modules.
7. Do not access the cache (address array, data array, associative purge area).
8. To detect the DREQ pin signal in single address mode, use edge detection.

DataSheet4U.com

et4U.com

DataShee

DataSheet4U.com

www.DataSheet4U.com

DataSheet4U.com

DataSheet4U.com

et4U.com

DataShee

DataSheet4U.com

www.DataSheet4U.com

Section 10 Division Unit

10.1 Overview

The division unit (DIVU) divides 64 bits by 32 bits and 32 bits by 32 bits. The results are expressed as a 32-bit quotient and a 32-bit remainder. When the operation produces an overflow, an interrupt can be generated as specified.

10.1.1 Features

The division unit has the following features:

- Performs signed division of 64 bits by 32 bits and 32 bits by 32 bits
- Handles 32-bit quotient, 32-bit remainder
- Completes operation execution in 39 cycles
- Controls enabling/disabling of over/underflow interrupts
- Even during the division process, instructions not accessing the division unit can be parallel-processed

DataSheet4U.com

et4U.com

DataShee

DataSheet4U.com

www.DataSheet4U.com

DataSheet4U.com

Figure 10.1 shows a block diagram of the division unit.

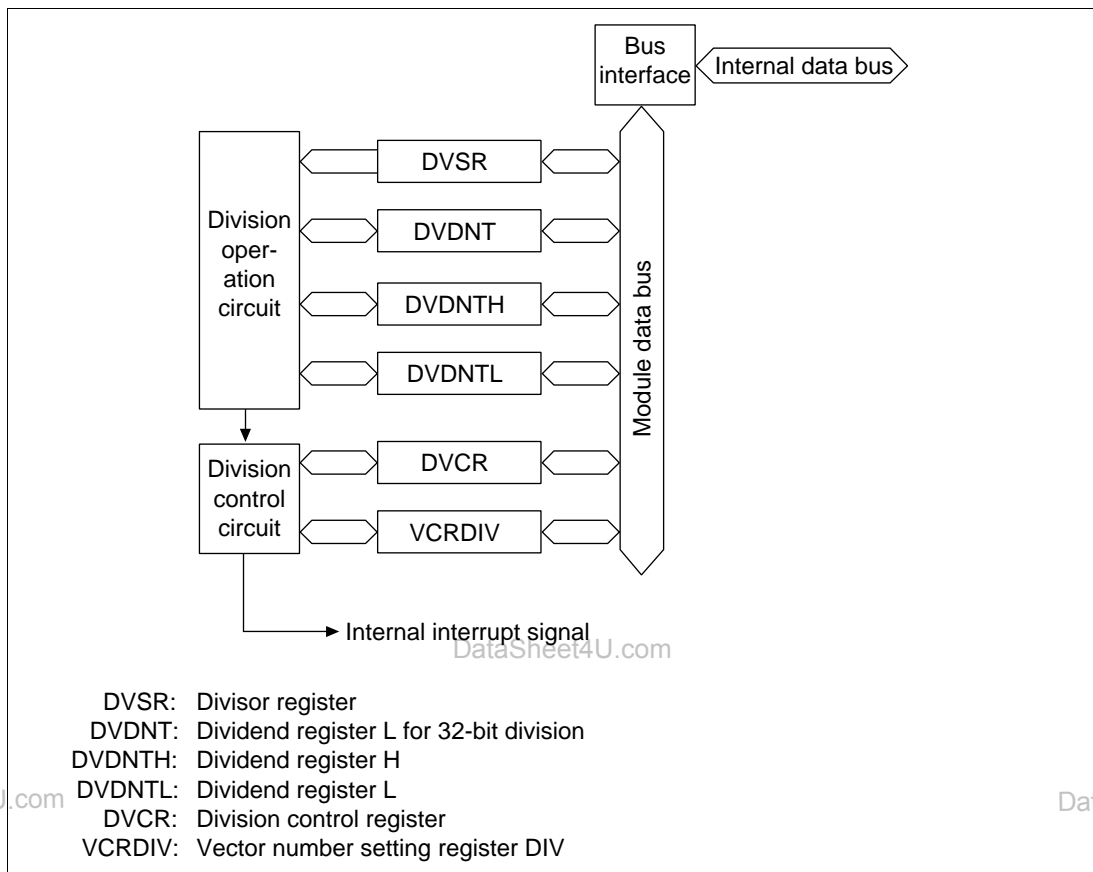

Figure 10.1 Division Unit Block Diagram

10.1.3 Register Configuration

Table 10.1 shows the register configuration of the division unit.

Table 10.1 Division Unit Register Configuration

Register	Abbr.	R/W	Initial Value	Address	Access Size ^{*1}
Divisor register	DVSR	R/W	Undefined	H'FFFFFFF00	32
Dividend register L for 32-bit division	DVDNT	R/W	Undefined	H'FFFFFFF04	32
Division control register	DVCR	R/W	H'00000000	H'FFFFFFF08	16, 32
Vector number setting register DIV	VCRDIV	R/W	Undefined ^{*2}	H'FFFFFFF0C	16, 32
Dividend register H	DVDNTH	R/W	Undefined	H'FFFFFFF10	32
Dividend register L	DVDNTL	R/W	Undefined	H'FFFFFFF14	32

- Notes: 1. Accesses to the division unit are read and written in 32-bit units. DVCR and VCRDIV permit 16 and 32-bit accesses. When registers other than CONT and VCRDIV are accessed with word accesses, undefined values are read or written.
2. The initial value of VCRDIV is H'0000**** (asterisks represent undefined values).

10.2 Description of Registers

10.2.1 Divisor Register (DVSR)

Bit:	31	30	29	...	3	2	1	0
Bit name:	<input type="text"/>	<input type="text"/>	<input type="text"/>	...	<input type="text"/>	<input type="text"/>	<input type="text"/>	<input type="text"/>
Initial value:	—	—	—	...	—	—	—	—
R/W:	R/W	R/W	R/W	...	R/W	R/W	R/W	R/W

The divisor register (DVSR) is a 32-bit read/write register in which the divisor for the operation is written. It is not initialized by a power-on reset or manual reset, in standby mode, or during module standbys.

10.2.2 Dividend Register L for 32-Bit Division (DVDNT)

Bit:	31	30	29	...	3	2	1	0
Bit name:	<input type="text"/>	<input type="text"/>	<input type="text"/>	...	<input type="text"/>	<input type="text"/>	<input type="text"/>	<input type="text"/>
Initial value:	—	—	—	...	—	—	—	—
R/W:	R/W	R/W	R/W	...	R/W	R/W	R/W	R/W

The dividend register L for 32-bit division (DVDNT) is a 32-bit read/write register in which the 32-bit dividend used for 32-bit ÷ 32-bit division operations is written. When 32-bit ÷ 32-bit division is run, the value set as the dividend is lost and the quotient written at the end of division. When this register is written to, the same value is written in the DVDNTL register. The MSB written is sign-extended in the DVDNTH register. Writing to this register starts the 32-bit ÷ 32-bit division operation. It is not initialized by a power-on reset or manual reset, in standby mode, or during module standbys.

10.2.3 Division Control Register (DVCR)

Bit:	31	30	29	...	3	2	1	0
Bit name:	—	—	—	...	—	—	OVFIE	OVF
Initial value:	0	0	0	...	0	0	0	0
R/W:	R	R	R	...	R	R	R/W	R/W

The division control register (DVCR) is a 32-bit read/write register, but is also 16-bit accessible. It controls enabling/disabling of the overflow interrupt. This register is initialized to H'00000000 by a power-on reset or manual reset. It is not initialized in standby mode or during module standbys.

- Bits 31 to 2: Reserved. These bits always read 0. The write value should always be 0.
- Bit 1: OVF Interrupt Enable (OVFIE): Selects enabling or disabling of the OVF interrupt request (OVFI) upon overflow.

Bit 1: OVFIE	Description
0	Interrupt request (OVFI) caused by OVF disabled (Initial value)
1	Interrupt request (OVFI) caused by OVF enabled

Note: Always set the OVFIE bit before starting the operation whenever executing interrupt handling for overflows.

- Bit 0: Overflow Flag (OVF). Flag indicating an overflow has occurred.

Bit 0: OVF	Description
0	No overflow has occurred (Initial value)
1	Overflow has occurred

10.2.4 Vector Number Setting Register DIV (VCRDIV)

Bit:	31	30	29	...	19	18	17	16
Bit name:	—	—	—	...	—	—	—	—
Initial value:	0	0	0	...	0	0	0	0
R/W:	R	R	R	...	R	R	R	R
Bit:	15	14	13	...	3	2	1	0
Bit name:				...				
Initial value:	—	—	—	...	—	—	—	—
R/W:	R/W	R/W	R/W	...	R/W	R/W	R/W	R/W

Vector number setting register DIV (VCRDIV) is a 32-bit read/write register, but is also 16-bit accessible. The destination vector number is set in VCRDIV when an interrupt occurs in the division unit due to an overflow or underflow. Values can be set in the 16 bits from bit 15 to bit 0, but only the last 7 bits (bits 6–0) are valid. Always set 0 for the 9 bits from bit 15 to bit 7. VCRDIV is not initialized by a power-on reset or manual reset, in standby mode, or during module standbys.

- Bits 31 to 7: Reserved. These bits always read 0. The write value should always be 0.
- Bits 6 to 0: Interrupt Vector Number. Sets the interrupt destination vector number. Only the 7 bits 6–0 are valid (as the vector number).

10.2.5 Dividend Register H (DVDNTH)

Bit:	31	30	29	...	3	2	1	0
Bit name:				...				
Initial value:	—	—	—	...	—	—	—	—
R/W:	R/W	R/W	R/W	...	R/W	R/W	R/W	R/W

Dividend register H (DVDNTH) is a 32-bit read/write register in which the upper 32 bits of the dividend used for 64 bit ÷ 32 bit division operations are written. When a division operation is executed, the value set as the dividend is lost and the remainder written here at the end of the operation. The initial value of DVDNTH is undefined, and its value is also undefined after a power-on reset or manual reset, in standby mode, and during in module standbys. When the DVDNT register is set with a dividend value, the previous DVDNTH value is lost and the MSB of the DVDNT register is extended to all bits in the DVDNTH register.

10.2.6 Dividend Register L (DVDNTL)

Bit:	31	30	39	...	3	2	1	0
Bit name:	<input type="text"/>	<input type="text"/>	<input type="text"/>	...	<input type="text"/>	<input type="text"/>	<input type="text"/>	<input type="text"/>
Initial value:	—	—	—	...	—	—	—	—
R/W:	R/W	R/W	R/W	...	R/W	R/W	R/W	R/W

Dividend register L (DVDNTL) is a 32-bit read/write register in which the lower 32 bits of the dividend used for 64-bit ÷ 32-bit division operations are written. When a value is set in this register, the 64-bit ÷ 32-bit division operation begins. The value written in the DVDNT register for 32-bit ÷ 32-bit division is also set in this register. When a 64-bit ÷ 32-bit division operation is executed, the value set as the dividend is lost and the quotient written here at the end of the operation. The contents of this register are undefined after a power-on reset or manual reset, in standby mode, and during module standbys.

10.3 Operation

10.3.1 64-Bit ÷ 32-Bit Operations

64-bit ÷ 32-bit operations work as follows:

1. The 32-bit divisor is set in the divisor register (DVSR).
2. The 64-bit dividend is set in dividend registers H and L (DVDNTH and DVDNTL). First set the value in DVDNTH. When a value is written to DVDNTL, the 64-bit ÷ 32-bit operation begins.
3. This unit finishes a single operation in 39 cycles (starting from the setting of the value in DVDNTL). When an overflow occurs, however, the operation ends in 6 cycles. See section 10.3.3, Handling of Overflows, for more information. Note that operation is signed.
4. After the operation, the 32-bit remainder is written to DVDNTH and the 32-bit quotient is written to DVDNTL.

10.3.2 32-Bit ÷ 32-Bit Operations

32-bit ÷ 32-bit operations work as follows:

1. The 32-bit divisor is set in the divisor register (DVSR).
2. The 32-bit dividend is set in dividend register L (DVDNT) for 32-bit division. When a value is written to DVDNT, the 32-bit ÷ 32-bit operation begins.
3. This unit finishes a single operation in 39 cycles (starting from the setting of the value in DVDNT). When an overflow occurs, however, the operation ends in 6 cycles. See section 10.3.3, Handling of Overflows, for more information. Note that the operation is signed.

4. After the operation, the 32-bit remainder is written to DVDNTH and the 32-bit quotient is written to DVDNT.

10.3.3 Handling of Overflows

When the results of operations exceed the ranges expressed as signed 32 bits (when, in division between two negative numbers, the quotient is the maximum value and a remainder (negative number) is generated) or when the divisor is 0, an overflow will result.

When an overflow occurs, the OVF bit is set and an overflow interrupt is generated if interrupt generation is enabled (the OVFIE bit in DVCR is 1). The operation will then end with the result after 6 cycles of operation stored in the DVDNTH and DVDNTL registers. If interrupt generation is disabled (the OVFIE bit is 0), the operation will end with the operation result at 6 cycles set in DVDNTH and the maximum value H'7FFFFFFF or minimum value H'80000000 set in DVDNTL. In the SH7604, the maximum value results when a positive quotient overflows; the minimum value results when a negative quotient overflows. The first three cycles of the 6 cycles executed when an overflow occurs are used for flag setting within the division unit and the next three for division.

10.4 Usage Notes

10.4.1 Access

DataSheet4U.com

All accesses to the division unit except DVCR and VCRDIV must be 32-bit reads or writes. Word accesses to registers other than DVCR and VCRDIV result in reading or writing of undefined values. In the division unit, a read instruction is extended for one cycle immediately after an instruction that writes to a register, even if the register is the same, to ensure that the value written is accurately set in the destination register in the division unit.

When a read or write instruction is issued while the division unit is operating, the read or write instruction is continuously extended until the operation ends. This means that instructions that do not access the division unit can be parallel-processed. When an instruction is executed that writes to any register of the division unit immediately following an instruction that writes to the division start-up registers (DVDNTL or DVDNT), the correct value may not be set in the start-up register. Specify an instruction other than one that writes to a division unit register for the instruction immediately following instruction that writes to a start-up register.

Because of the above restrictions, efficient processing can be achieved by executing instructions that do not access the division unit for 39 cycles after starting the operation, then issuing a read instruction after the 39th cycle.

10.4.2 Overflow Flag

When an overflow occurs, the overflow flag (OVF) is set and is not automatically reset. When OVF is set, the operation is not affected. When necessary, clear it before the operation. The states of registers when overflow occurs are shown in table 10.2.

Table 10.2 Overflow Processing

Register	Overflow Interrupt Enabled	Overflow Interrupt Disabled
DVSR	Holds the value written	Holds the value written
DVDNT	Holds the results of operations until overflow generation is detected*	The maximum value is set for overflow to the plus side, or the minimum value for overflow to the minus side
DVCR	The OVF bit is set	The OVF bit is set
VCRDIV	Holds the value written	Holds the value written
DVDNTH	Holds the results of operations until overflow generation is detected*	Holds the results of operations until overflow generation is detected *
DVDNTL	Holds the results of operations until overflow generation is detected*	The maximum value is set for overflow to the plus side, or the minimum value for overflow to the minus side

Note: In division processing, the intermediate operation result is written for cycles up to detection of overflow generation.

DataSheet4U.com

Section 11 16-Bit Free-Running Timer

11.1 Overview

The SH7604 has a single-channel, 16-bit free-running timer (FRT) on-chip. The FRT is based on a 16-bit free-running counter (FRC) and can output two types of independent waveforms. The FRT can also measure the width of input pulses and the cycle of external clocks.

11.1.1 Features

The FRT has the following features:

- Allows selection between four types of counter input clocks. Select from external clock or three types of internal clocks ($\phi/8$, $\phi/32$, and $\phi/128$). (External events can be counted.)
- Two independent comparators. Two types of waveforms can be output.
- Input capture. Select rising edge or falling edge.
- Counter clear can be specified. The counter value can be cleared upon compare match A.
- Four types of interrupt sources. Two compare matches, one input capture, and one overflow are available as interrupt sources, and interrupts can be requested independently for each.

DataSheet4U.com

et4U.com

DataShee

DataSheet4U.com

www.DataSheet4U.com

DataSheet4U.com

Figure 11.1 shows a block diagram of the FRT.

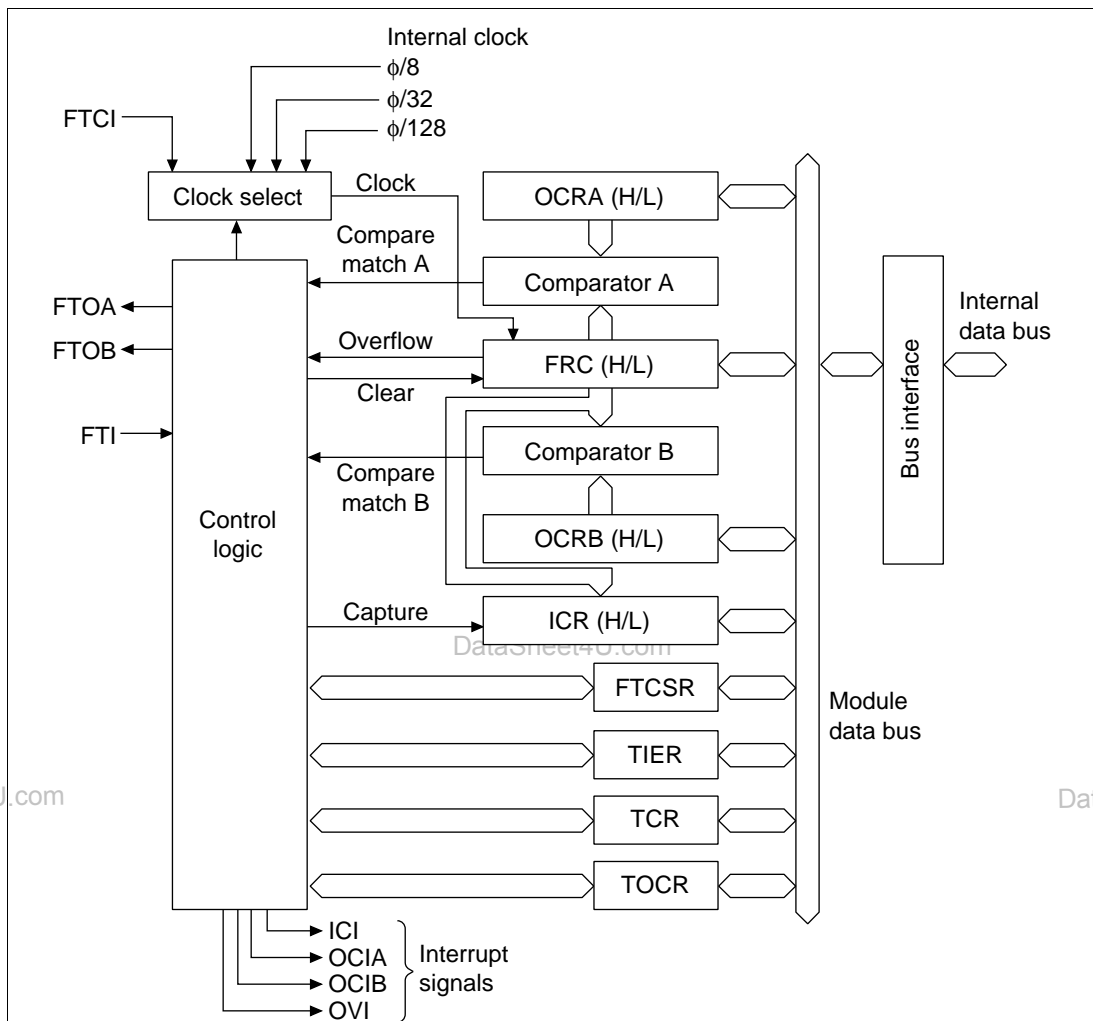

- OCRA,B: Output compare registers A,B (16 bits)
- FRC: Free-running counter (16 bits)
- ICR: Input capture register (16 bits)
- TCR: Timer control register (8 bits)
- TIER: Timer interrupt enable register (8 bits)
- FTCSR: Free-running timer control/status register (8 bits)
- TOCR: Timer output compare control register (8 bits)

Figure 11.1 FRT Block Diagram

11.1.3 Pin Configuration

Table 11.1 lists FRT I/O pins and their functions.

Table 11.1 Pin Configuration

Channel	Pin	I/O	Function
Counter clock input pin	FTCI	I	FRC counter clock input pin
Output compare A output pin	FTOA	O	Output pin for output compare A
Output compare B output pin	FTOB	O	Output pin for output compare B
Input capture input pin	FTI	I	Input pin for input capture

11.1.4 Register Configuration

Table 11.2 shows the FRT register configuration.

Table 11.2 Register Configuration

Register	Abbreviation	R/W	Initial Value	Address
Timer interrupt enable register	TIER	R/W	H'01	HFFFFFFE10
Free-running timer control/status register	FTCSR	R/(W)*1	H'00	HFFFFFFE11
Free-running counter H	FRC H	R/W	H'00	HFFFFFFE12
Free-running counter L	FRC L	R/W	H'00	HFFFFFFE13
Output compare register A H	OCRA H	R/W	H'FF	HFFFFFFE14*2
Output compare register A L	OCRA L	R/W	H'FF	HFFFFFFE15*2
Output compare register B H	OCRB H	R/W	H'FF	HFFFFFFE14*2
Output compare register B L	OCRB L	R/W	H'FF	HFFFFFFE15*2
Timer control register	TCR	R/W	H'00	HFFFFFFE16
Timer output compare control register	TOCR	R/W	H'E0	HFFFFFFE17
Input capture register H	ICR H	R	H'00	HFFFFFFE18
Input capture register L	ICR L	R	H'00	HFFFFFFE19

- Notes:
1. Bits 7 to 1 are read-only. The only value that can be written is a 0, which is used to clear flags. Bit 0 can be read or written.
 2. OCRA and OCRB have the same address. The OCRS bit in TOCR is used to switch between them.
 3. Use byte-size access for all registers.

11.2 Register Descriptions

11.2.1 Free-Running Counter (FRC)

Bit:	15	14	13	...	3	2	1	0
Bit name:	<input type="text"/>	<input type="text"/>	<input type="text"/>	...	<input type="text"/>	<input type="text"/>	<input type="text"/>	<input type="text"/>
Initial value:	0	0	0	...	0	0	0	0
R/W:	R/W	R/W	R/W	...	R/W	R/W	R/W	R/W

FRC is a 16-bit read/write up-counter. It increments upon input of a clock. The input clock can be selected using clock select bits 1 and 0 (CKS1, CKS0) in TCR. FRC can be cleared upon compare match A.

When FRC overflows (H'FFFF → H'0000), the overflow flag (OVF) in FTCSR is set to 1. FRC can be read or written to by the CPU, but because it is 16 bits long, data transfers involving the CPU are performed via a temporary register (TEMP). See section 11.3, CPU Interface, for more detailed information.

FRC is initialized to H'0000 by a reset, in standby mode, and when the module standby function is used.

11.2.2 Output Compare Registers A and B (OCRA and OCRB)

Bit:	15	14	13	...	3	2	1	0
Bit name:	<input type="text"/>	<input type="text"/>	<input type="text"/>	...	<input type="text"/>	<input type="text"/>	<input type="text"/>	<input type="text"/>
Initial value:	1	1	1	...	1	1	1	1
R/W:	R/W	R/W	R/W	...	R/W	R/W	R/W	R/W

OCR is composed of two 16-bit read/write registers (OCRA and OCRB). The contents of OCR are always compared to the FRC value. When the two values are the same, the output compare flags in FTCSR (OCFA and OCFB) are set to 1.

When the OCR and FRC values are the same (compare match), the output level values set in the output level bits (OLVLA and OLVLB) are output to the output compare pins (FTOA and FTOB). After a reset, FTOA and FTOB output 0 until the first compare match occurs.

Because OCR is a 16-bit register, data transfers involving the CPU are performed via a temporary register (TEMP). See section 11.3, CPU Interface, for more detailed information.

OCR is initialized to H'FFFF by a reset, in standby mode, and when the module standby function is used.

11.2.3 Input Capture Register (ICR)

Bit:	15	14	13	...	3	2	1	0
Bit name:				...				
Initial value:	0	0	0	...	0	0	0	0
R/W:	R	R	R	...	R	R	R	R

ICR is a 16-bit read-only register. When a rising edge or falling edge of the input capture signal is detected, the current FRC value is transferred to ICR. At the same time, the input capture flag (ICF) in FTCSR is set to 1. The edge of the input signal can be selected using the input edge select bit (IEDGA) in TCR.

Because ICR is a 16-bit register, data transfers involving the CPU are performed via a temporary register (TEMP). See Section 11.3, CPU Interface, for more detailed information. To ensure that the input capture operation is reliably performed, set the pulse width of the input capture input signal to six system clocks (ϕ) or more.

ICR is initialized to H'0000 by a reset, in standby mode, and when the module standby function is used.

11.2.4 Timer Interrupt Enable Register (TIER)

Bit:	7	6	5	4	3	2	1	0
Bit name:	ICIE	—	—	—	OCIAE	OCIBE	OVIE	—
Initial value:	0	0	0	0	0	0	0	1
R/W:	R/W	—	—	—	R/W	R/W	R/W	—

TIER is an 8-bit read/write register that controls enabling of all interrupt requests. TIER is initialized to H'01 by a reset, in standby mode, and when the module standby function is used.

- Bit 7—Input Capture Interrupt Enable (ICIE): Selects enabling/disabling of the ICI interrupt request when the input capture flag (ICF) in FTCSR is set to 1.

Bit 7: ICIE	Description
0	Interrupt request (ICI) caused by ICF disabled (Initial value)
1	Interrupt request (ICI) caused by ICF enabled

- Bits 6 to 4—Reserved: These bits always read 0. The write value should always be 0. Do not write 1.

- Bit 3—Output Compare Interrupt A Enable (OCIAE): Selects enabling/disabling of the OCIA interrupt request when the output compare flag A (OCFA) in FTCSR is set to 1.

Bit 3: OCIAE	Description
0	Interrupt request (OCIA) caused by OCFA disabled (Initial value)
1	Interrupt request (OCIA) caused by OCFA enabled

- Bit 2—Output Compare Interrupt B Enable (OCIBE): Selects enabling/disabling of the OCIB interrupt request when the output compare flag B (OCFB) in FTCSR is set to 1.

Bit 2: OCIBE	Description
0	Interrupt request (OCIB) caused by OCFB disabled (Initial value)
1	Interrupt request (OCIB) caused by OCFB enabled

- Bit 1—Timer Overflow Interrupt Enable (OVIE): Selects enabling/disabling of the OVI interrupt request when the overflow flag (OVF) in FTCSR is set to 1.

Bit 1: OVIE	Description
0	Interrupt request (FOVI) caused by OVF disabled (initial value)
1	Interrupt request (FOVI) caused by OVF enabled

DataSheet4U.com

- Bit 0—Reserved: This bit always reads 1. The write value should always be 1.

11.2.5 Free-Running Timer Control/Status Register (FTCSR)

Bit:	7	6	5	4	3	2	1	0
Bit name:	ICF	—	—	—	OCFA	OCFB	OVF	CCLRA
Initial value:	0	0	0	0	0	0	0	0
R/W:	R/(W)*	—	—	—	R/(W)*	R/(W)*	R/(W)*	R/W

Note: For bits 7, and 3 to 1, the only value that can be written is 0 (to clear the flags).

FTCSR is an 8-bit register that selects counter clearing and controls interrupt request signals. FTCSR is initialized to H'00 by a reset, in standby mode, and when the module standby function is used. See section 11.4, Operation, for the timing.

- Bit 7—Input Capture Flag (ICF): Status flag that indicates that the FRC value has been sent to FICR by the input capture signal. This flag is cleared by software and set by hardware. It cannot be set by software.

Bit 7: ICF	Description
0	Clear conditions: When ICF is read while set to 1, and then 0 is written to it (Initial value)
1	Set conditions: When the FRC value is sent to ICR by the input capture signal

- Bits 6 to 4—Reserved: These bits always read 0. The write value should always be 0.
- Bit 3—Output Compare Flag A (OCFA): Status flag that indicates when the values of the FRC and OCRA match. This flag is cleared by software and set by hardware. It cannot be set by software.

Bit 3: OCFA	Description
0	Clear conditions: When OCFA is read while set to 1, and then 0 is written to it (Initial value)
1	Set conditions: When the FRC value becomes equal to OCRA

- Bit 2—Output Compare Flag B (OCFB): Status flag that indicates when the values of FRC and OCRB match. This flag is cleared by software and set by hardware. It cannot be set by software.

Bit 2: OCFB	Description
0	Clear conditions: When OCFB is read while set to 1, and then 0 is written to it (Initial value)
1	Set conditions: When the FRC value becomes equal to OCRB

- Bit 1—Timer Overflow Flag (OVF): Status flag that indicates when FRC overflows (from H'FFFF to H'0000). This flag is cleared by software and set by hardware. It cannot be set by software.

Bit 1: OVF	Description
0	Clear conditions: When OVF is read while set to 1, and then 0 is written to it (Initial value)
1	Set conditions: When the FRC value changes from H'FFFF to H'0000

- Bit 0—Counter Clear A (CCLRA): Selects whether or not to clear FRC on compare match A (signal indicating match of FRC and OCRA).

Bit 0: CCLRA	Description
0	FRC clear disabled (Initial value)
1	FRC cleared on compare match A

11.2.6 Timer Control Register (TCR)

Bit:	7	6	5	4	3	2	1	0
Bit name:	IEDGA	—	—	—	—	—	CKS1	CKS0
Initial value:	0	0	0	0	0	0	0	0
R/W:	R/W	R/W	R/W	R/W	R/W	R/W	R/W	R/W

TCR is an 8-bit read/write register that selects the input edge for input capture and selects the input clock for FRC. TCR is initialized to H'00 by a reset, in standby mode, and when the module standby function is used.

- Bit 7—Input Edge Select (IEDG): Selects whether to capture the input capture input (FTI) on the falling edge or rising edge.

Bit 7: IEDG	Description
0	Input captured on falling edge (Initial value)
1	Input captured on rising edge

- Bits 6 to 2—Reserved: These bits always read 0. The write value should always be 0. Do not write 1.
- Bits 1 and 0—Clock Select (CKS1, CKS0): These bits select whether to use an external clock or one of three internal clocks for input to FRC. The external clock is counted at the rising edge.

Bit 1: CKS1	Bit 0: CKS0	Description
0	0	Internal clock: count at $\phi/8$ (Initial value)
	1	Internal clock: count at $\phi/32$
1	0	Internal clock: count at $\phi/128$
	1	External clock: count at rising edge

11.2.7 Timer Output Compare Control Register (TOCR)

Bit:	7	6	5	4	3	2	1	0
Bit name:	—	—	—	OCRS	—	—	OLVLA	OLVLB
Initial value:	1	1	1	0	0	0	0	0
R/W:	—	—	—	R/W	R/W	R/W	R/W	R/W

TOCR is an 8-bit read/write register that selects the output level for output compare, enables output compare output, and controls switching between access of output compare registers A and B. TOCR is initialized to H'E0 by a reset, in standby mode, and when the module standby function is used.

Bits 7 to 5—Reserved: These bits always read 1. The write value should always be 1. Do not write 0.

Bit 4—Output Compare Register Select (OCRS): OCRA and OCRB share the same address. The OCRS bit controls which register is selected when reading/writing to this address. It does not affect the operation of OCRA and OCRB.

Bit 4: OCRS	Description
0	OCRA register selected (Initial value)
1	OCRB register selected

Bits 3 and 2—Reserved: These bits always read 0. The write value should always be 0. Do not write 1.

Bit 1—Output Level A (OLVLA): Selects the level output to the output compare A output pin upon compare match A (signal indicating match of FRC and OCRA).

Bit 1: OLVLA	Description
0	0 output on compare match A (Initial value)
1	1 output on compare match A

Bit 0—Output Level B (OLVLB): Selects the level output to the output compare B output pin upon compare match B (signal indicating match of FRC and OCRB).

Bit 0: OLVLB	Description
0	0 output on compare match B (Initial value)
1	1 output on compare match B

11.3 CPU Interface

FRC, OCRA, OCRB, and FICR are 16-bit registers. The data bus width between the CPU and FRT, however, is only 8 bits. Access of these three types of registers from the CPU therefore needs to be performed via an 8-bit temporary register called TEMP.

The following describes how these registers are read from and written to:

- Writing to 16-bit Registers

The upper byte is written, which results in the upper byte of data being stored in TEMP. The lower byte is then written, which results in 16 bits of data being written to the register when combined with the upper byte value in TEMP.

- Reading from 16-bit Registers

The upper byte of data is read, which results in the upper byte value being transferred to the CPU. The lower byte value is transferred to TEMP. The lower byte is then read, which results in the lower byte value in TEMP being sent to the CPU.

When registers of these three types are accessed, two byte accesses should always be performed, first to the upper byte, then the lower byte. The same applies to accesses with the on-chip direct memory access controller. If only the upper byte or lower byte is accessed, the data will not be transferred properly.

Figure 11.2 and 11.3 show the flow of data when FRC is accessed. Other registers function in the same way. When reading OCRA and OCRB, however, both upper and lower-byte data is transferred directly to the CPU without passing through TEMP.

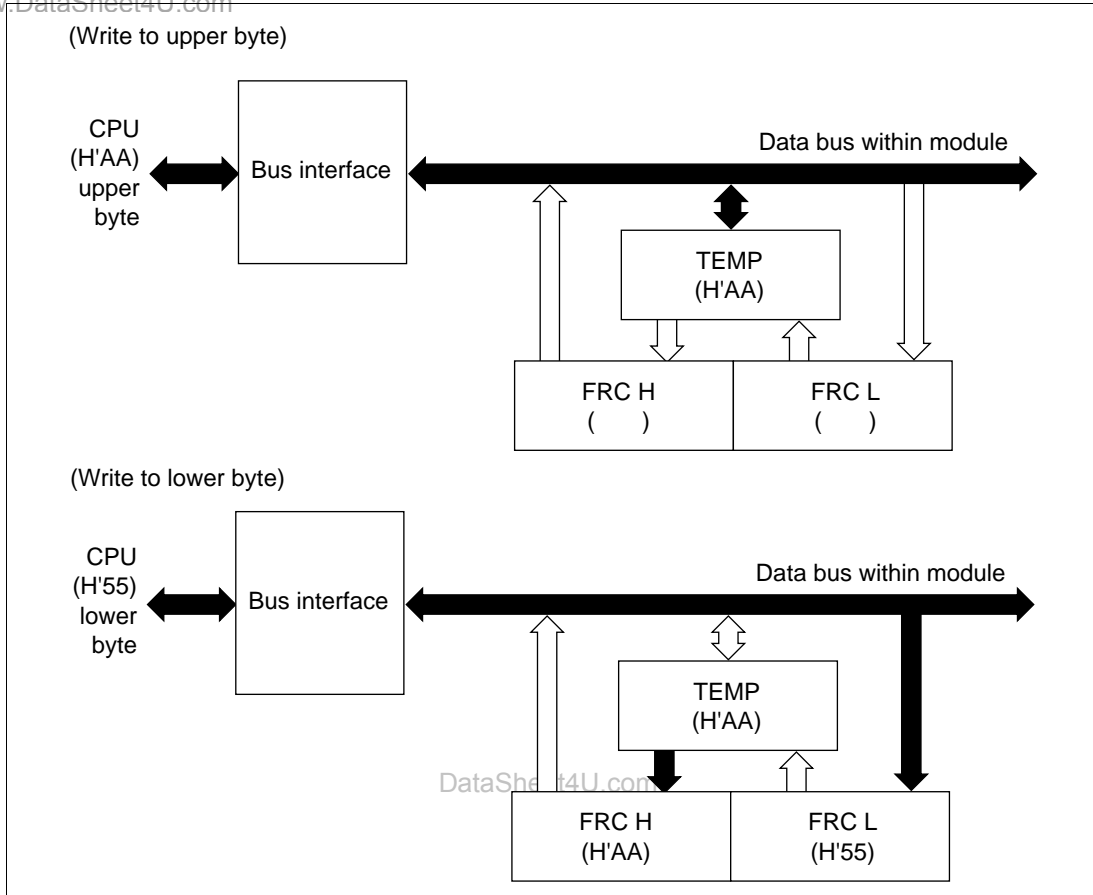

Figure 11.2 FRC Access Operation (CPU Writes H'AA55 to FRC)

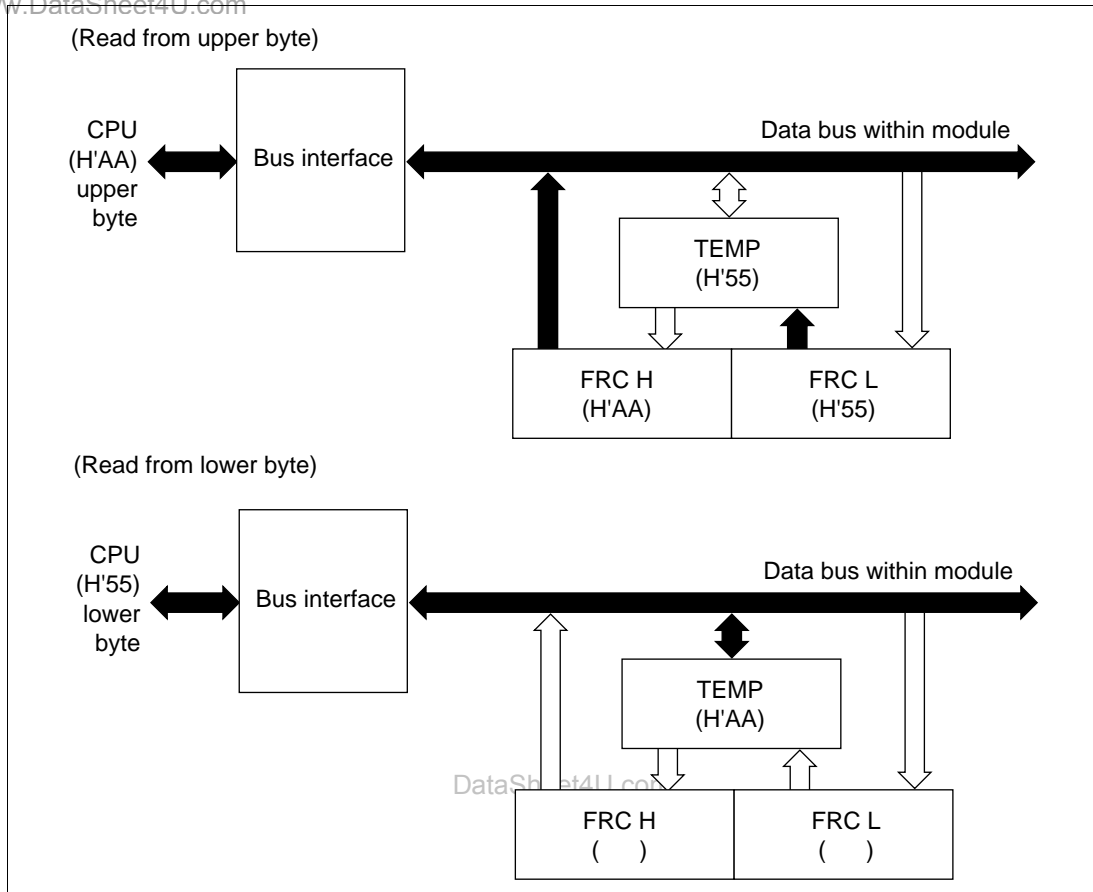

Figure 11.3 FRC Access Operation (CPU Reads H'AA55 from FRC)

11.4.1 FRC Count Timing

The FRC increments on clock input (internal or external).

Internal Clock Operation: Set the CKS1 and CKS0 bits in TCR to select which of the three internal clocks created by dividing system clock ϕ ($\phi/8$, $\phi/32$, $\phi/128$) is used. Figure 11.4 shows the timing.

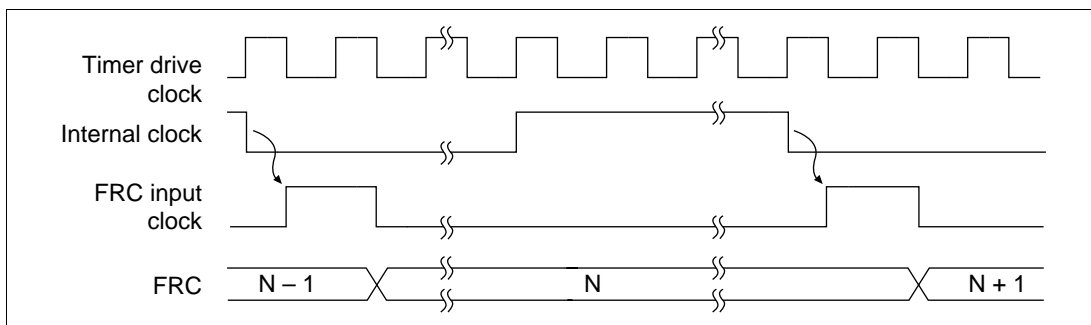

Figure 11.4 Count Timing (Internal Clock Operation)

External Clock Operation: Set the CKS1 and CKS0 bits in TCR to select the external clock. External clock pulses are counted on the rising edge. The pulse width of the external clock must be at least 6 system clocks (ϕ). A smaller pulse width will result in inaccurate operation. Figures 11.5 shows the timing.

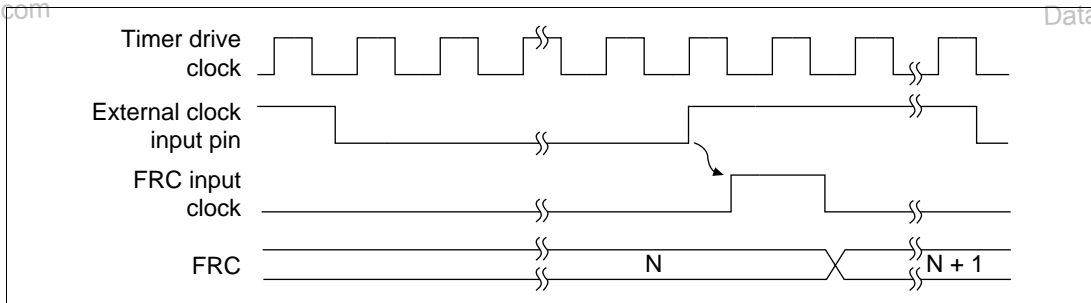

Figure 11.5 Count Timing (External Clock Operation)

11.4.2 Output Timing for Output Compare

When a compare match occurs, the output level set in the OLVL bit in TOCR is output from the output compare output pins (FTOA, FTOB). Figure 11.6 shows the timing for output of output compare A.

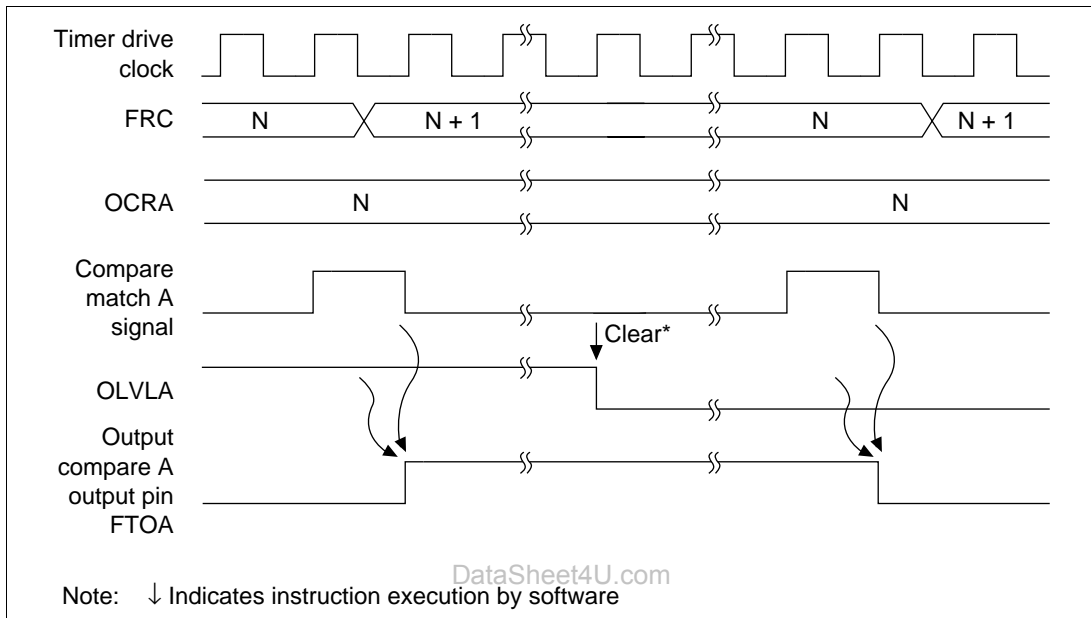

Figure 11.6 Output Timing for Output Compare A

11.4.3 FRC Clear Timing

FRC can be cleared on compare match A. Figure 11.7 shows the timing.

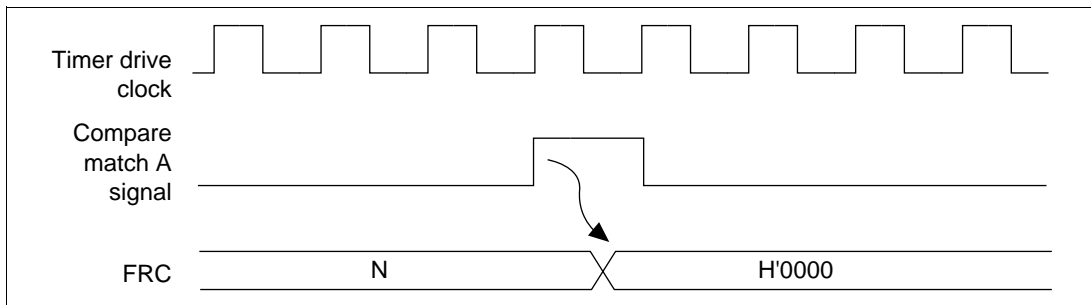

Figure 11.7 Compare Match A Clear Timing

11.4.4 Input Capture Input Timing

Either the rising edge or falling edge, can be selected for input capture input using the IEDG bit in TCR. Figure 11.8 shows the timing when the rising edge is selected (IEDG = 1).

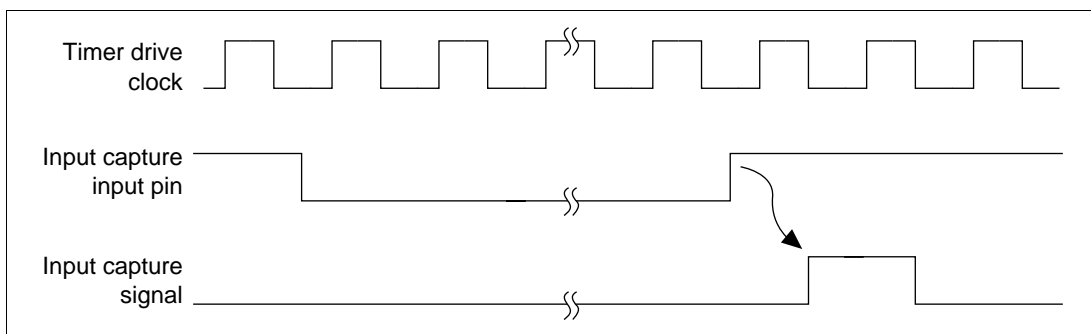

Figure 11.8 Input Capture Signal Timing (Normal)

When the input capture signal is input when ICR is read (upper-byte read), the input capture signal is delayed by one cycle of the clock that drives the timer. Figure 11.9 shows the timing.

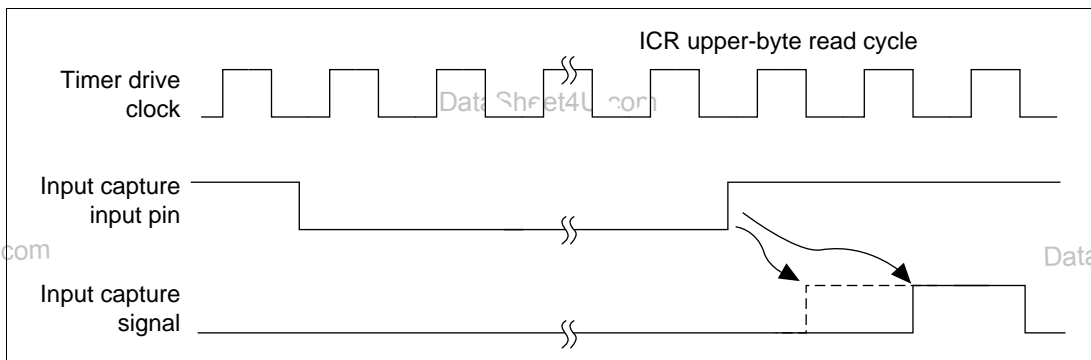

Figure 11.9 Input Capture Signal Timing (Input Capture Input when ICR is Read)

11.4.5 Input Capture Flag (ICF) Setting Timing

Input capture input sets the input capture flag (ICF) to 1 and simultaneously transfers the FRC value to ICR. Figure 11.10 shows the timing.

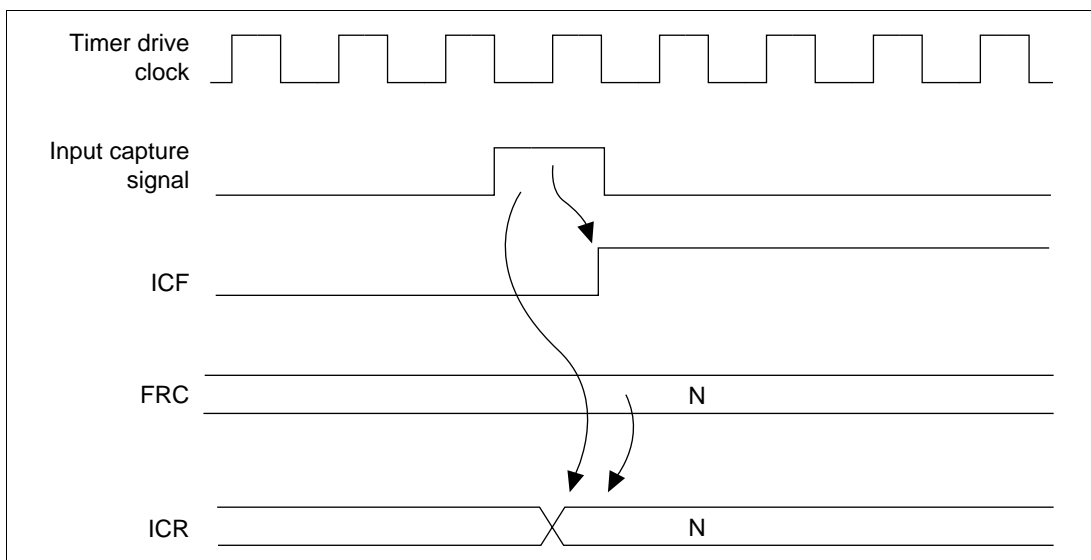

Figure 11.10 ICF Setting Timing

11.4.6 Output Compare Flag (OCFA, OCFB) Setting Timing

The compare match signal output (when OCRA or OCRB matches the FRC value) sets output compare flag OCFA or OCFB to 1. The compare match signal is generated in the last state in which the values matched (at the timing for updating the count value that matched the FRC). After OCRA or OCRB matches the FRC, no compare match signal is generated until the increment lock is generated. Figure 11.11 shows the timing for setting OCFA and OCFB.

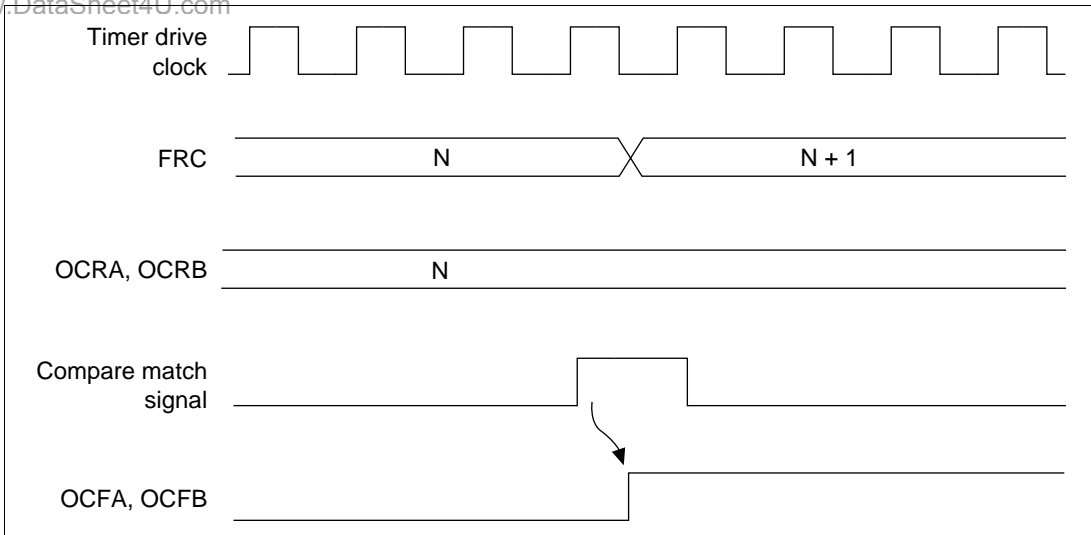

Figure 11.11 OCF Setting Timing

11.4.7 Timer Overflow Flag (OVF) Setting Timing

FRC overflow (from H'FFFF to H'0000) sets the timer overflow flag (OVF) to 1. Figure 11.12 shows the timing.

DataSheet4U.com

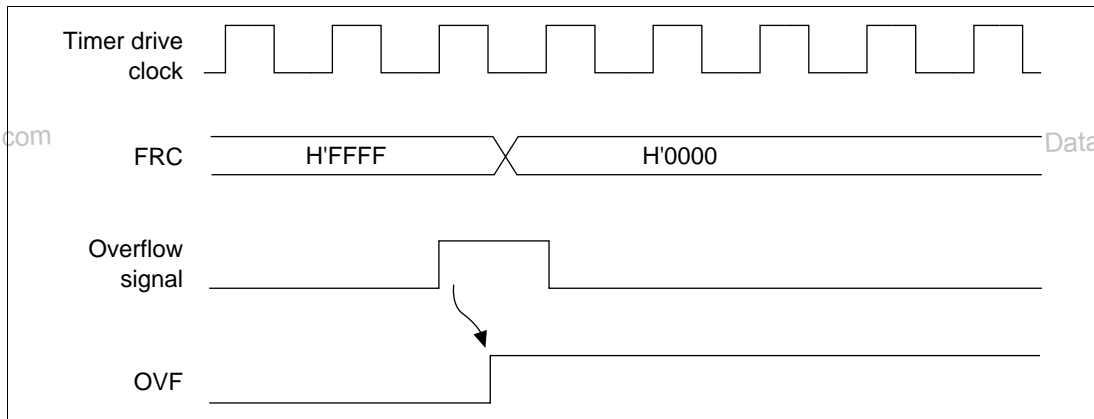

Figure 11.12 OVF Setting Timing

11.5 Interrupt Sources

There are four FRT interrupt sources of three types (ICI, OCIA/OCIB, and OVI). Table 11.3 lists the interrupt sources and their priorities after a reset is cleared. The interrupt enable bits in TIER are used to enable or disable the interrupt bits. Each interrupt request is sent to the interrupt controller independently. See section 4, Exception Handling, for more information about priorities and the relationship to interrupts other than those of the FRT.

Table 11.3 FRT Interrupt Sources and Priorities

Interrupt Source	Description	Priority
ICI	Interrupt by ICF	High
OCIA, OCIB	Interrupt by OCFA or OCFB	↑
OVI	Interrupt by OVF	Low

11.6 Example of FRT Use

Figure 11.13 shows an example in which pulses with a 50% duty factor and arbitrary phase relationship are output. The procedure is as follows:

1. Set the CCLRA bit in FTCSR to 1.
2. The OLVLA and OLVLB bits are inverted by software whenever a compare match occurs.

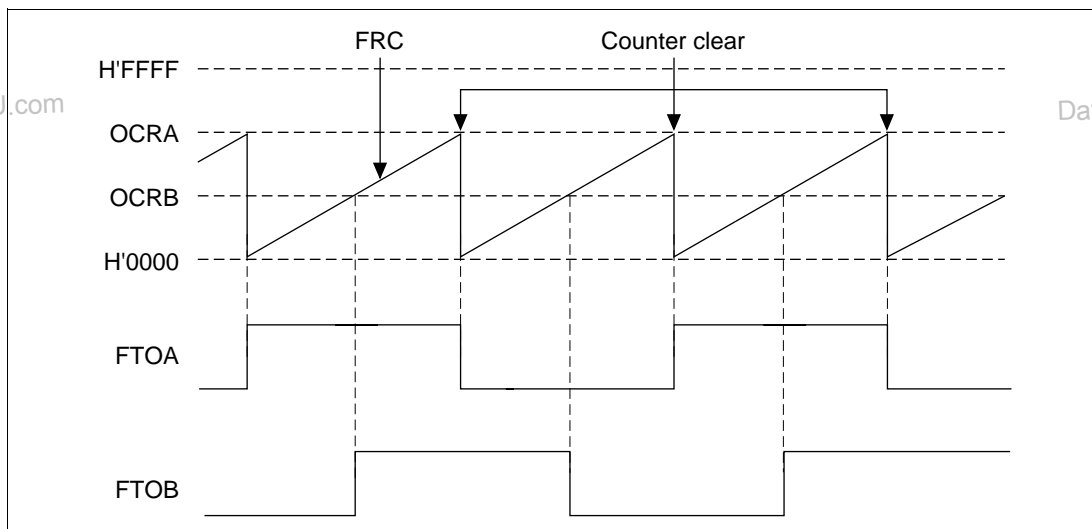

Figure 11.13 Example of Pulse Output

11.7 Usage Notes

Note that the following contention and operations occur when the FRC is operating:

1. FRC operates on the timer drive clock ($\phi/4$), which has a cycle of 4 times the system clock (ϕ). For this reason, when the CPU performs an access, both the CPU and FRC will be operating, so a WAIT request will be generated from the FRC to the CPU. The number of access cycles thus varies by between 3 and 12 cycles.
2. Contention between FRC Write and Clear

When a counter clear signal is generated with the timing shown in figure 11.14 during the write cycle for the lower byte of FRC, writing does not occur to the FRC, and the FRC clear takes priority.

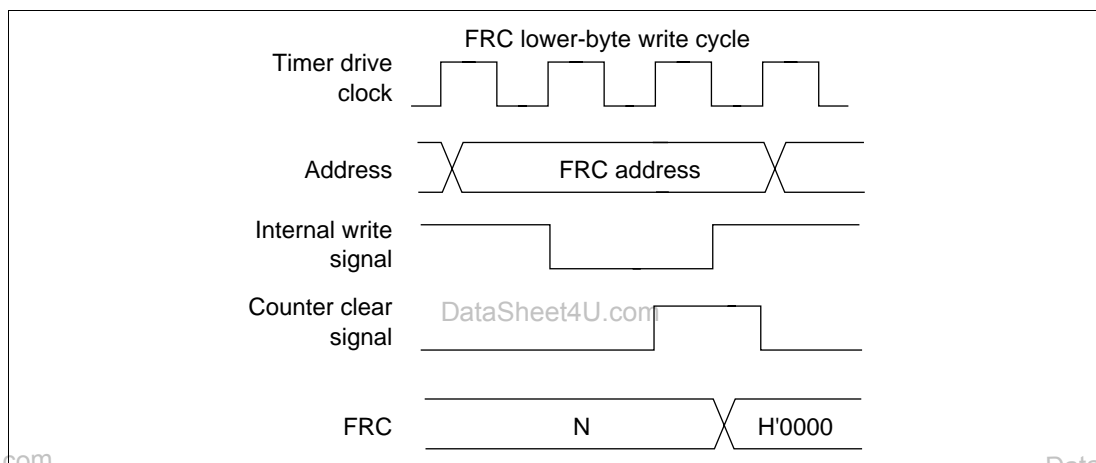

Figure 11.14 Contention between FRC Write and Clear

3. Contention between FRC Write and Increment

When an increment occurs with the timing shown in figure 11.15 during the write cycle for the lower byte of FRC, no increment is performed and the counter write takes priority.

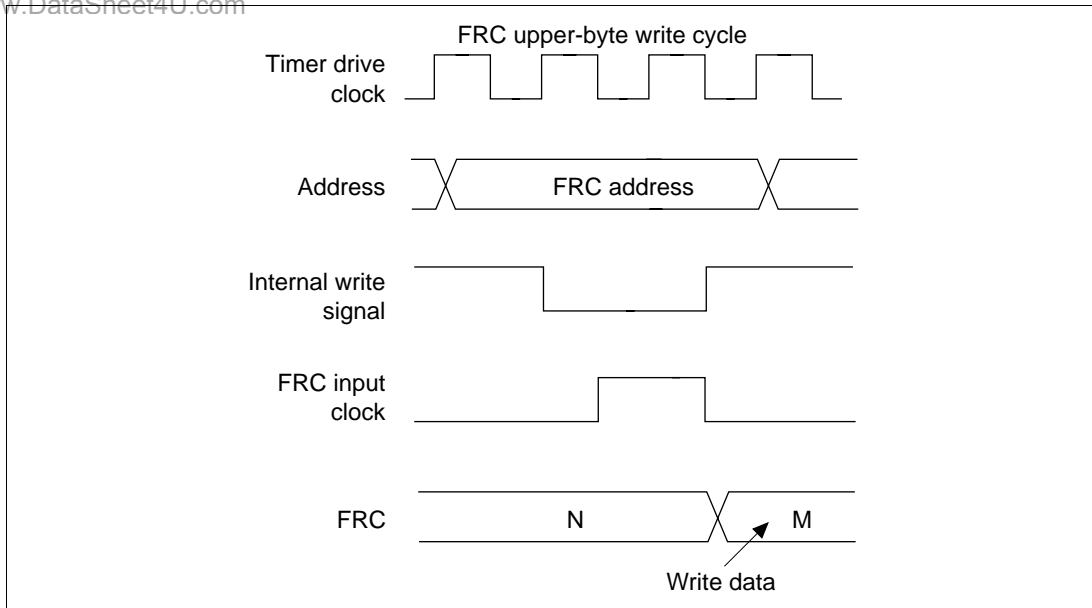

Figure 11.15 Contention between FRC Write and Increment

4. Contention between OCR Write and Compare Match

When a compare match occurs with the timing shown in figure 11.16, during the write cycle for the lower byte of OCRA or OCRB, the OCR write takes priority and the compare match signal is disabled.

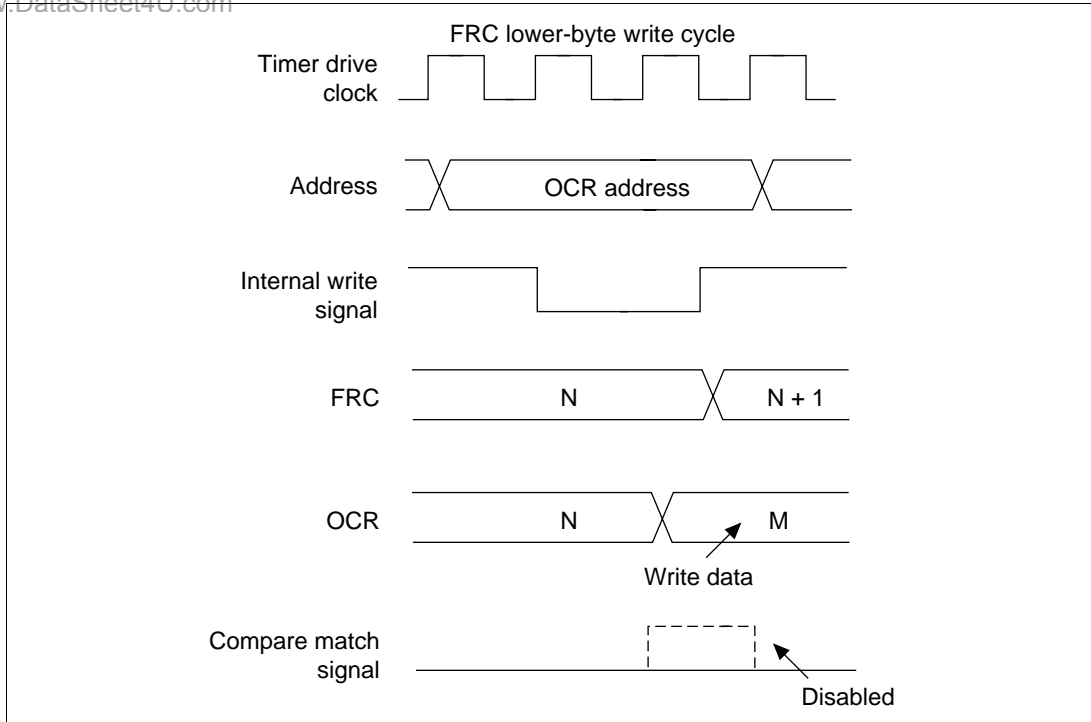

Figure 11.16 Contention between OCR and Compare Match

DataSheet4U.com

5. Internal Clock Switching and Counter Operation

FRC will sometimes begin incrementing because of the timing of switching between internal clocks. Table 11.4 shows the relationship between internal clock switching timing (CKS1 and CKS0 bit rewrites) and FRC operation.

When an internal clock is used, the FRC clock is generated when the falling edge of an internal clock (created by dividing the system clock (ϕ)) is detected. When a clock is switched to high before the switching and to low after switching, as shown in case 3 in table 11.4, the switchover is considered a falling edge and an FRC clock pulse is generated, causing FRC to increment. FRC may also increment when switching between an internal clock and an external clock.

Table 11.4 Internal Clock Switching and FRC Operation

**Timing of Rewrite of
No. CKS1 and CKS0 Bits**

FRC Operation

1 Low-to-low switch

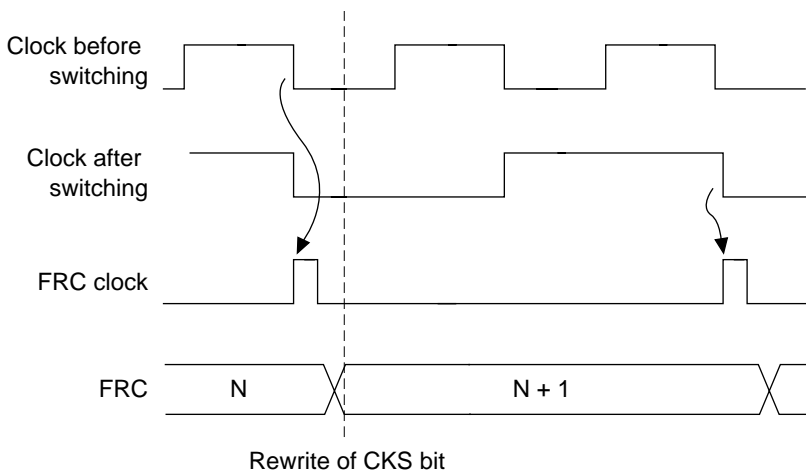

2 Low-to-high switch

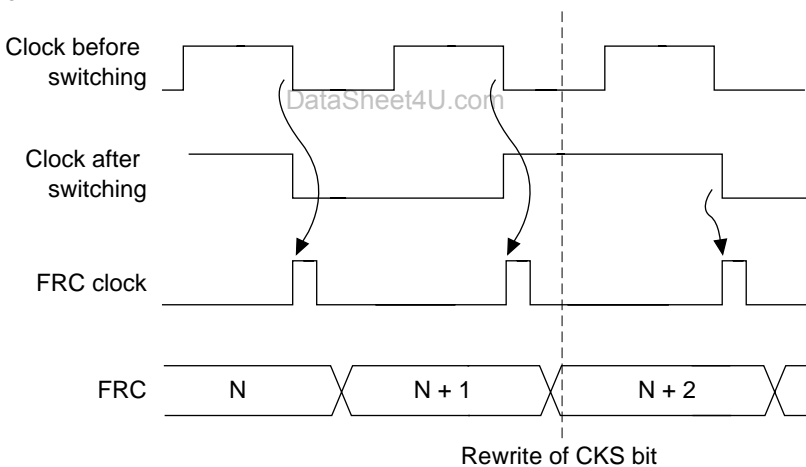
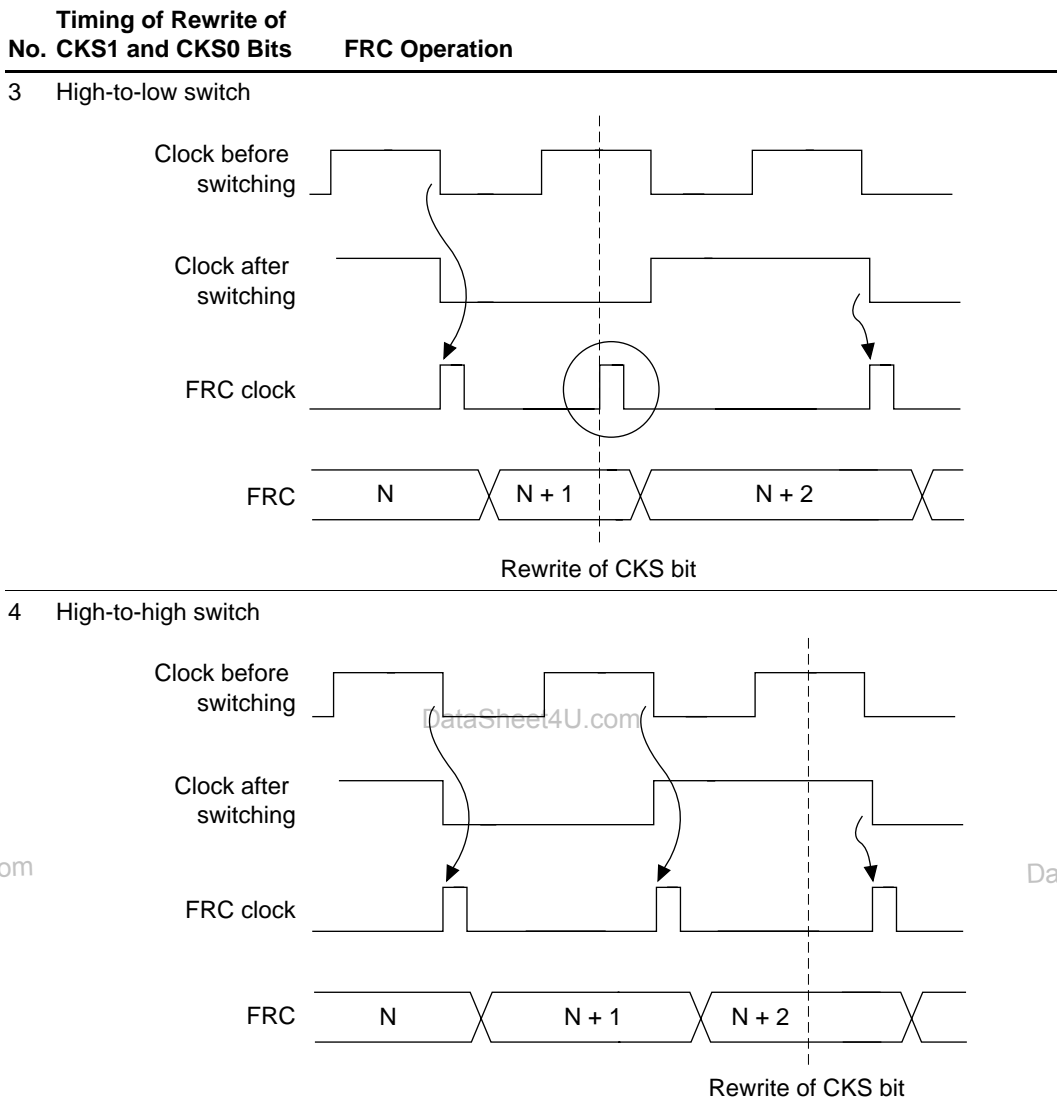

Table 11.4 Internal Clock Switching and FRC Operation (cont)

Note: Because the switchover is considered a falling edge, FRC starts counting up.

6. Timer Output (FTOA, FTOB)

During a power-on reset, the timer outputs (FTOA, FTOB) will be unreliable until the oscillation stabilizes. The initial value is output after the oscillation settling time has elapsed.

DataSheet4U.com

et4U.com

DataShee

DataSheet4U.com

www.DataSheet4U.com

Section 12 Watchdog Timer (WDT)

12.1 Overview

The SH7604 has a single-channel watchdog timer (WDT) for monitoring system operations. If a system becomes uncontrolled and the timer counter overflows without being rewritten correctly by the CPU, an overflow signal ($\overline{\text{WDTOVF}}$) is output externally. The WDT can simultaneously generate an internal reset signal for the entire chip.

When this watchdog function is not needed, the WDT can be used as an interval timer. In the interval timer operation, an interval timer interrupt is generated at each counter overflow. The WDT is also used when recovering from standby mode, in modifying a clock frequency, and in clock pause mode.

12.1.1 Features

- Works in watchdog timer mode or interval timer mode.
- Outputs $\overline{\text{WDTOVF}}$ in watchdog timer mode. When the counter overflows in watchdog timer mode, overflow signal $\overline{\text{WDTOVF}}$ is output externally. It is possible to select whether to reset the chip internally when this happens. Either the power-on reset or manual reset signal can be selected as the internal reset signal.
- Generates interrupts in interval timer mode. When the counter overflows, it generates an interval timer interrupt.
- Used for standby mode clearing, clock frequency modification, and clock pause mode.
- Works with eight counter clock sources.

Figure 12.1 shows a block diagram of the WDT.

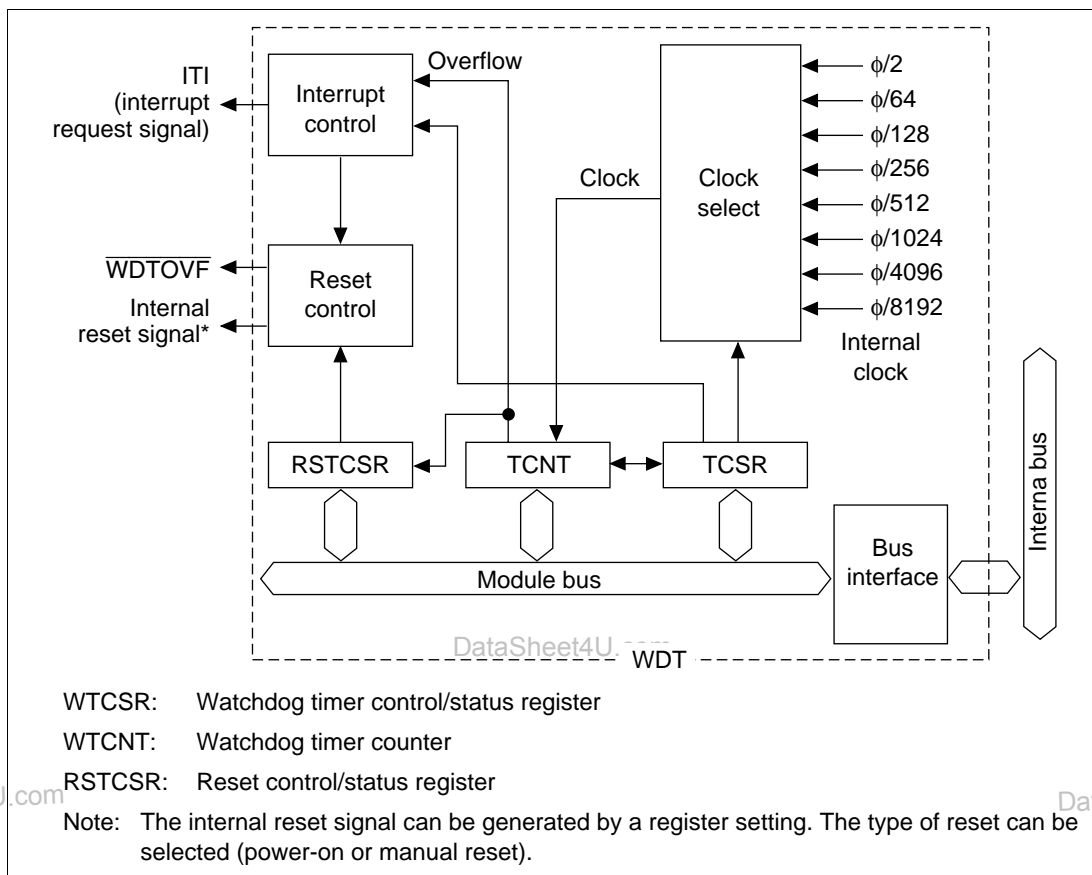

Figure 12.1 WDT Block Diagram

12.1.3 Pin Configuration

Table 12.1 shows the pin configuration.

Table 12.1 Pin Configuration

Pin	Abbreviation	I/O	Function
Watchdog timer overflow	WDTOVF	O	Outputs the counter overflow signal in watchdog mode

12.1.4 Register Configuration

Table 12.2 summarizes the three WDT registers. They are used to select the clock, switch the WDT mode, and control the reset signal.

Table 12.2 WDT Registers

Name	Abbreviation	R/W	Initial Value	Address	
				Write ^{*1}	Read ^{*2}
Watchdog timer control/status register	WTCSR	R/(W) ^{*3}	H'18	H'FFFFFFE80	H'FFFFFFE80
Watchdog timer counter	WTCNT	R/W	H'00	H'FFFFFFE80	H'FFFFFFE81
Reset control/status register	RSTCSR	R/(W) ^{*3}	H'1F	H'FFFFFFE82	H'FFFFFFE83

- Notes: 1. Write by word access. It cannot be written by byte or longword access.
 2. Read by byte access. The correct value cannot be read by word or longword access.
 3. Only 0 can be written in bit 7 to clear the flag.

12.2 Register Descriptions

12.2.1 Watchdog Timer Counter (WTCNT)

WTCNT is an 8-bit read/write up-counter. WTCNT differs from other registers in that it is more difficult to write. See section 12.2.4, Register Access, for details. When the timer enable bit (TME) in the watchdog timer control/status register (WTCSR) is set to 1, the watchdog timer counter starts counting pulses of an internal clock source selected by clock select bits 2 to 0 (CKS2 to CKS0) in WTCSR. When the value of WTCNT overflows (changes from H'FF to H'00), a watchdog timer overflow signal ($\overline{\text{WDTOV}}\overline{\text{F}}$) or interval timer interrupt (ITI) is generated, depending on the mode selected in the $\overline{\text{WT}}/\overline{\text{IT}}$ bit in WTCSR. WTCNT is initialized to H'00 by a reset and when the TME bit is cleared to 0. It is not initialized in standby mode.

Bit:	7	6	5	4	3	2	1	0
Bit name:								
Initial value:	0	0	0	0	0	0	0	0
R/W:	R/W	R/W	R/W	R/W	R/W	R/W	R/W	R/W

12.2.2 Watchdog Timer Control/Status Register (WTCSR)

The watchdog timer control/status register (WTCSR) is an 8-bit read/write register. WTCSR differs from other registers in being more difficult to write. See section 12.2.4, Register Access, for details. Its functions include selecting the timer mode and clock source. Bits 7 to 5 are initialized to 000 by a reset and in standby mode. Bits 2 to 0 are initialized to 000 by a reset, but retain their values in standby mode.

Bit:	7	6	5	4	3	2	1	0
Bit name:	OVF	WT/ $\overline{\text{IT}}$	TME	—	—	CKS2	CKS1	CKS0
Initial value:	0	0	0	1	1	0	0	0
R/W:	R/(W)	R/W	R/W	—	—	R/W	R/W	R/W

- Bit 7—Overflow Flag (OVF): Indicates that WTCNT has overflowed from H'FF to H'00. It is not set in watchdog timer mode.

Bit 7: OVF	Description
0	No overflow of WTCNT in interval timer mode (Initial value) Cleared by reading OVF, then writing 0 in OVF
1	WTCNT overflow in interval timer mode

- Bit 6—Timer Mode Select (WT/ $\overline{\text{IT}}$): Selects whether to use the WDT as a watchdog timer or interval timer. When WTCNT overflows, the WDT either generates an interval timer interrupt (ITI) or generates a $\overline{\text{WDTOVF}}$ signal, depending on the mode selected.

Bit 6: WT/ $\overline{\text{IT}}$	Description
0	Interval timer mode: interval timer interrupt (ITI) request to the CPU when WTCNT overflows (Initial value)
1	Watchdog timer mode: $\overline{\text{WDTOVF}}$ signal output externally when WTCNT overflows. Section 12.2.3, Reset Control/Status Register (RSTCSR), describes in detail what happens when WTCNT overflows in watchdog timer mode.

- Bit 5—Timer Enable (TME): Enables or disables the timer.

Bit 5: TME	Description
0	Timer disabled: WTCNT is initialized to H'00 and count-up stops (Initial value)
1	Timer enabled: WTCNT starts counting. A $\overline{\text{WDTOVF}}$ signal or interrupt is generated when WTCNT overflows.

- Bits 4 and 3—Reserved: These bits always read 1. The write value should always be 1.
- Bits 2 to 0—Clock Select 2 to 0 (CKS2 to CKS0): These bits select one of eight internal clock sources for input to WTCNT. The clock signals are obtained by dividing the frequency of the system clock (ϕ).

				Description	
Bit 2: CKS2	Bit 1: CKS1	Bit 0: CKS0	Clock Source	Overflow Interval* ($\phi = 28.7 \text{ MHz}$)	
0	0	0	$\phi/2$ (Initial value)	17.8 μs	
0	0	1	$\phi/64$	570.8 μs	
0	1	0	$\phi/128$	1.1 ms	
0	1	1	$\phi/256$	2.2 ms	
1	0	0	$\phi/512$	4.5 ms	
1	0	1	$\phi/1024$	9.1 ms	
1	1	0	$\phi/4096$	36.5 ms	
1	1	1	$\phi/8192$	73.0 ms	

Note: The overflow interval listed is the time from when the WTCNT begins counting at H'00 until an overflow occurs.

12.2.3 Reset Control/Status Register (RSTCSR)

RSTCSR is an eight-bit read/write register that controls output of the reset signal generated by watchdog timer counter (WTCNT) overflow and selects the internal reset signal type. RSTCSR differs from other registers in that it is more difficult to write. See section 12.2.4, Register Access, for details. RSTCSR is initialized to H'1F by input of a reset signal from the RES pin, but is not initialized by the internal reset signal generated by overflow of the WDT. It is initialized to H'1F in standby mode.

Bit:	7	6	5	4	3	2	1	0
Bit name:	WOVF	RSTE	RSTS	—	—	—	—	—
Initial value:	0	0	0	1	1	1	1	1
R/W:	R/(W)*	R/W	R/W	—	—	—	—	—

Note: Only 0 can be written in bit 7 to clear the flag.

- Bit 7—Watchdog Timer Overflow Flag (WOVF): Indicates that WTCNT has overflowed (from H'FF to H'00) in watchdog timer mode. It is not set in interval timer mode.

Bit 7: WOVF	Description
0	No WTCNT overflow in watchdog timer mode (Initial value) Cleared by reading WOVF, then writing 0 in WOVF
1	Set by WTCNT overflow in watchdog timer mode

- Bit 6—Reset Enable (RSTE): Selects whether to reset the chip internally if WTCNT overflows in watchdog timer mode.

Bit 6: RSTE	Description
0	Not reset when WTCNT overflows (Initial value) LSI not reset internally, but WTCNT and WTCSR reset within WDT
1	Reset when WTCNT overflows

- Bit 5—Reset Select (RSTS): Selects the type of internal reset generated if WTCNT overflows in watchdog timer mode.

Bit 5: RSTS	Description
0	Power-on reset (Initial value)
1	Manual reset

- Bits 4 to 0—Reserved: These bits always read as 1. The write value should always be 1.

12.2.4 Register Access

The watchdog timer's WTCNT, WTCSR, and RSTCSR registers differ from other registers in that they are more difficult to write. The procedures for writing and reading these registers are given below.

Writing to WTCNT and WTCSR: These registers must be written by a word transfer instruction. They cannot be written by byte or longword transfer instructions. WTCNT and WTCSR both have the same write address. The write data must be contained in the lower byte of the written word. The upper byte must be H'5A (for WTCNT) or H'A5 (for WTCSR) (figure 12.2). This transfers the write data from the lower byte to WTCNT or WTCSR.

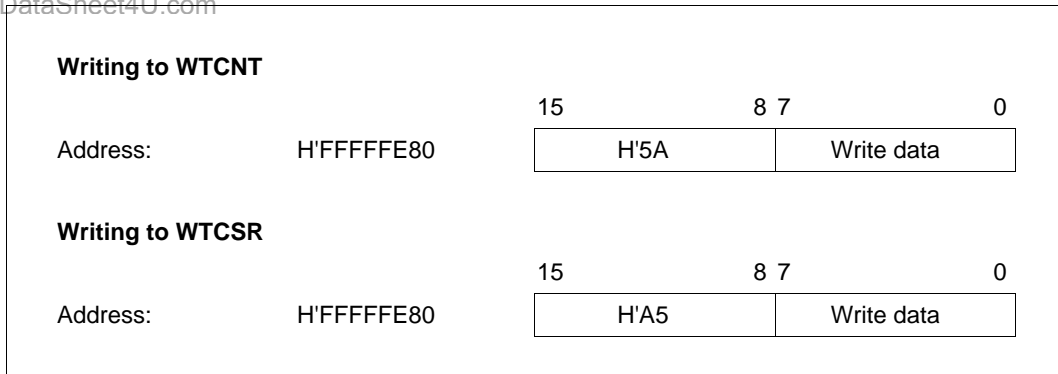

Figure 12.2 Writing to WTCNT and WTCNR

Writing to RSTCSR: RSTCSR must be written by a word access to address H'FFFFFFE82. It cannot be written by byte or longword transfer instructions. Procedures for writing 0 in WOVF (bit 7) and for writing to RSTE (bit 6) and RSTS (bit 5) are different, as shown in figure 12.3. To write 0 in the WOVF bit, the write data must be H'A5 in the upper byte and H'00 in the lower byte. This clears the WOVF bit to 0. The RSTE and RSTS bits are not affected. To write to the RSTE and RSTS bits, the upper byte must be H'5A and the lower byte must be the write data. The values of bits 6 and 5 of the lower byte are transferred to the RSTE and RSTS bits, respectively. The WOVF bit is not affected.

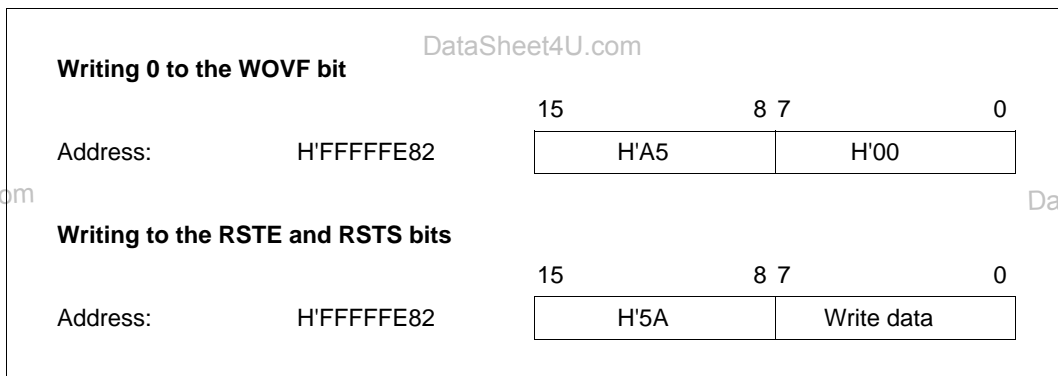

Figure 12.3 Writing to RSTCSR

Reading from WTCNT, WTCNR, and RSTCSR: WTCNT, WTCNR, and RSTCSR are read like other registers. Use byte transfer instructions. The read addresses are H'FFFFFFE80 for WTCNR, H'FFFFFFE81 for WTCNT, and H'FFFFFFE83 for RSTCSR.

12.3 Operation

12.3.1 Operation in Watchdog Timer Mode

To use the WDT as a watchdog timer, set the $\overline{WT/IT}$ and TME bits in WTCSR to 1. Software must prevent WTCNT overflow by rewriting the WTCNT value (normally by writing H'00) before overflow occurs. If WTCNT fails to be rewritten and overflows occur due to a system crash or the like, a \overline{WDTOVF} signal is output (figure 12.4). The \overline{WDTOVF} signal can be used to reset the system. The \overline{WDTOVF} signal is output for 128 ϕ clock cycles.

If the RSTE bit in RSTCSR is set to 1, a signal to reset the chip will be generated internally simultaneously with the \overline{WDTOVF} signal when WTCNT overflows. Either a power-on reset or a manual reset can be selected by the RSTS bit. The internal reset signal is output for 512 ϕ clock cycles.

When a watchdog reset is generated simultaneously with input at the \overline{RES} pin, the software distinguishes the \overline{RES} reset from the watchdog reset by checking the WOVF bit in RSTCSR. The \overline{RES} reset takes priority. The WOVF bit is cleared to 0.

DataSheet4U.com

et4U.com

DataShee

DataSheet4U.com

www.DataSheet4U.com

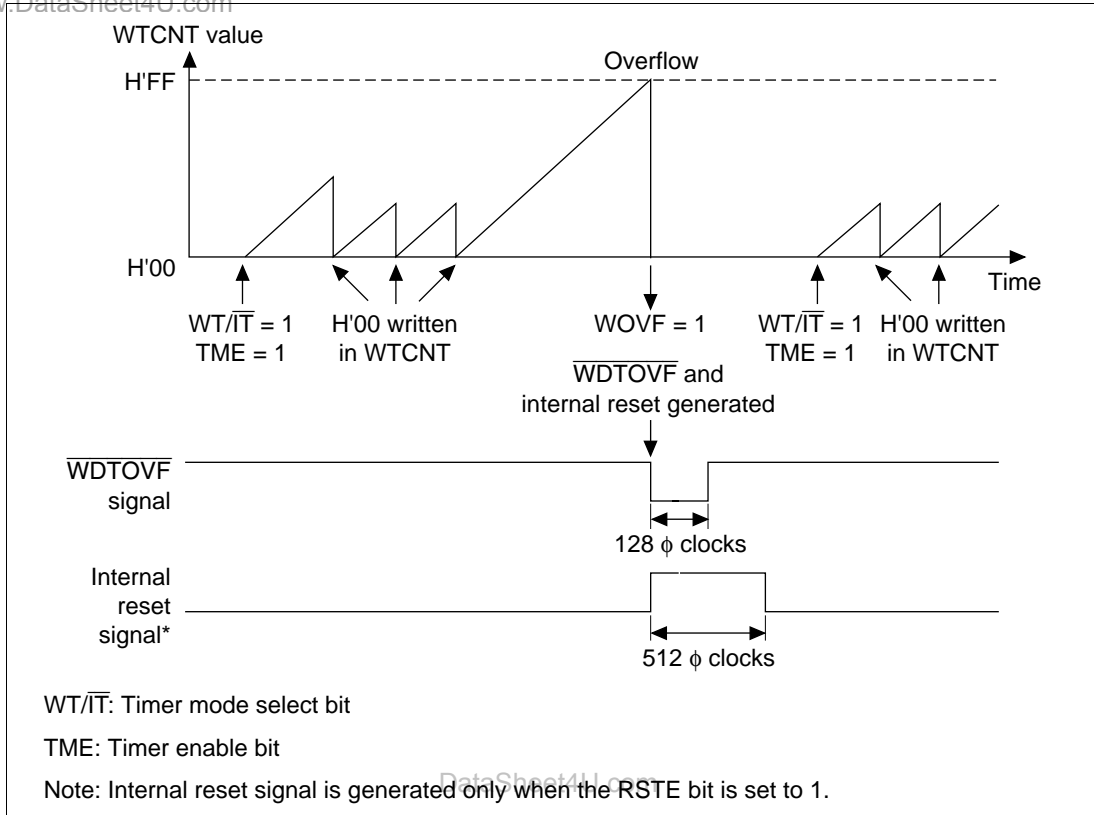

Figure 12.4 Operation in Watchdog Timer Mode

12.3.2 Operation in Interval Timer Mode

To use the WDT as an interval timer, clear WT/\overline{IT} to 0 and set TME to 1 in WTSCR. An interval timer interrupt (ITI) is generated each time the watchdog timer counter (WTCNT) overflows. This function can be used to generate interval timer interrupts at regular intervals (figure 12.5).

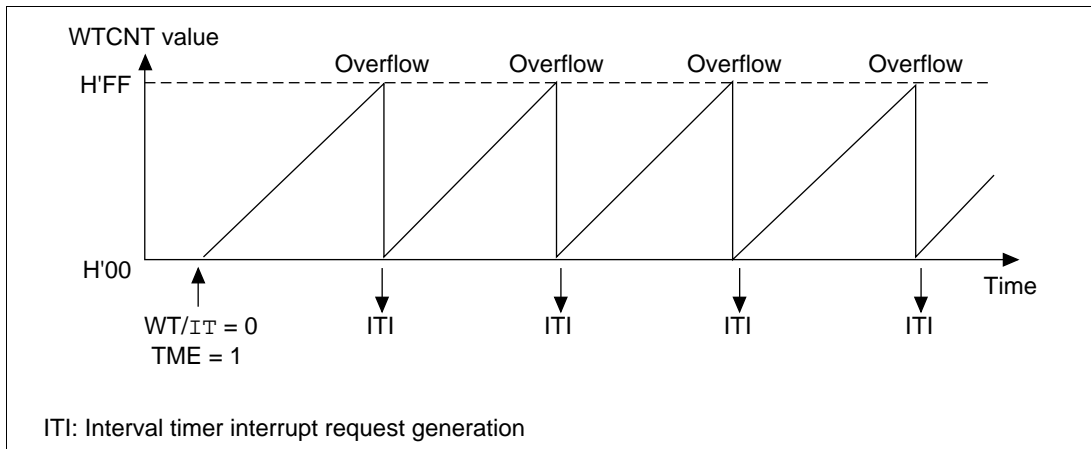

Figure 12.5 Operation in Interval Timer Mode

12.3.3 Operation in Standby Mode DataSheet4U.com

The watchdog timer has a special function to clear standby mode with an NMI interrupt. When using standby mode, set the WDT as described below.

Transition to Standby Mode: The TME bit in WTCSR must be cleared to 0 to stop the watchdog timer counter before it enters standby mode. The chip cannot enter standby mode while the TME bit is set to 1. Set bits CKS2 to CKS0 in WTCSR so that the counter overflow interval is equal to or longer than the oscillation settling time. See section 15.3, AC Characteristics, for the oscillation settling time.

Recovery from Standby Mode: When an NMI request signal is received in standby mode the clock oscillator starts running and the watchdog timer starts counting at the rate selected by bits CKS2 to CKS0 before standby mode was entered. When WTCNT overflows (changes from H'FF to H'00) the system clock (ϕ) is presumed to be stable and usable; clock signals are supplied to the entire chip and standby mode ends.

For details on standby mode, see section 14, Power Down Modes.

12.3.4 Timing of Overflow Flag (OVF) Setting

In interval timer mode, when WTCNT overflows, the OVF flag in WTCSR is set to 1 and an interval timer interrupt (ITI) is requested (figure 12.6).

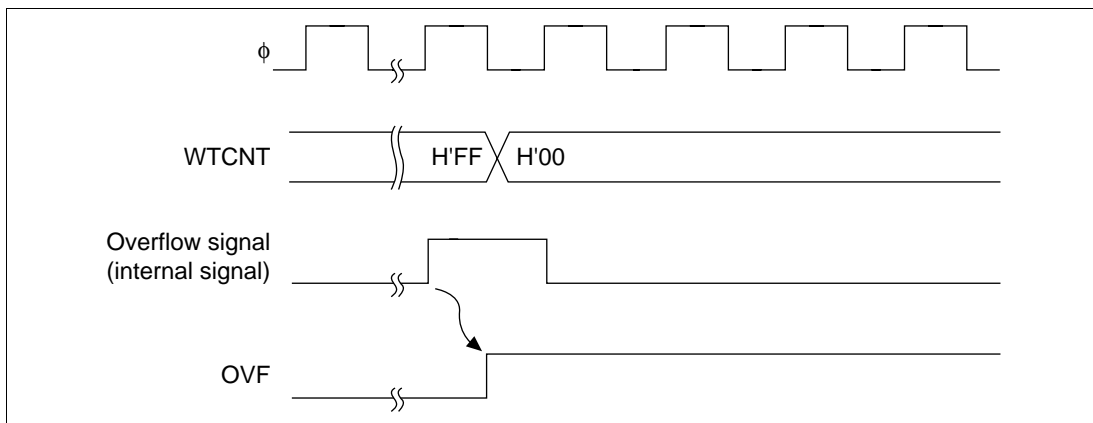

Figure 12.6 Timing of OVF Setting

12.3.5 Timing of Watchdog Timer Overflow Flag (WOVF) Setting

When WTCNT overflows the WOVF flag in RSTCSR is set to 1 and a $\overline{\text{WDTOVF}}$ signal is output. When the RSTE bit is set to 1, WTCNT overflow enables an internal reset signal to be generated for the entire chip (figure 12.7).

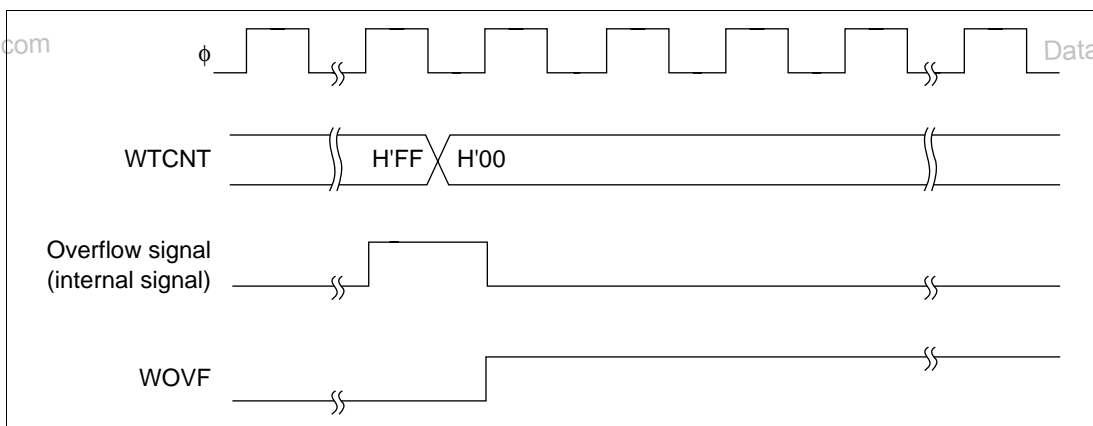

Figure 12.7 Timing of WOVF Setting

12.4.1 Contention between WTCNT Write and Increment

If a timer counter clock pulse is generated during the T3 state of a write cycle to WTCNT, the write takes priority and the timer counter is not incremented (figure 12.8).

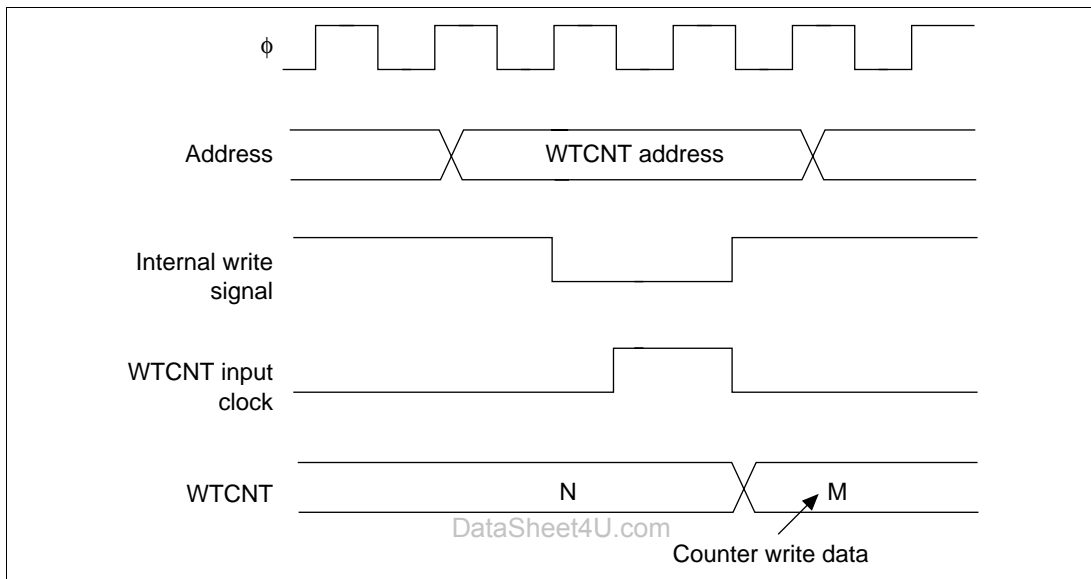

Figure 12.8 Contention between WTCNT Write and Increment

12.4.2 Changing CKS2 to CKS0 Bit Values

If the values of bits CKS2 to CKS0 are altered while the WDT is running, the count may increment incorrectly. Always stop the watchdog timer (by clearing the TME bit to 0) before changing the values of bits CKS2 to CKS0.

12.4.3 Switching between Watchdog Timer and Interval Timer Mode

To prevent incorrect operation, always stop the watchdog timer (by clearing the TME bit to 0) before switching between interval timer mode and watchdog timer mode.

12.4.4 System Reset with $\overline{\text{WDTOVF}}$

If a $\overline{\text{WDTOVF}}$ signal is input to the $\overline{\text{RES}}$ pin, the device cannot initialize correctly. Avoid logical input of the $\overline{\text{WDTOVF}}$ output signal to the $\overline{\text{RES}}$ input pin. To reset the entire system with the $\overline{\text{WDTOVF}}$ signal, use the circuit shown in figure 12.9.

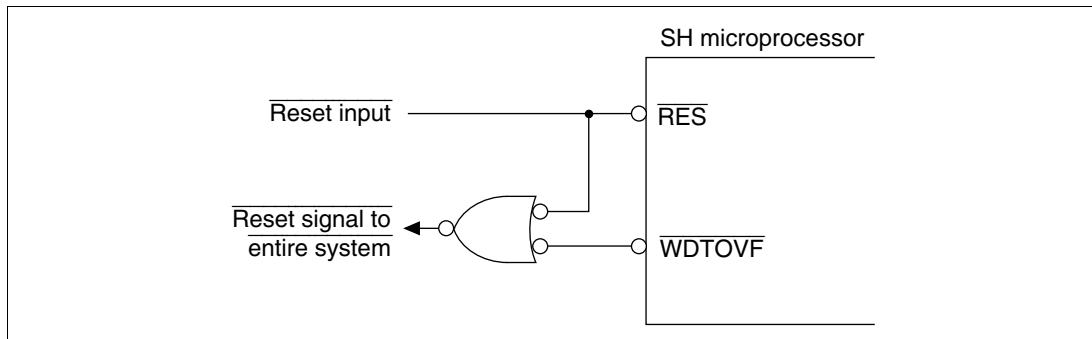

Figure 12.9 Example of Circuit for System Reset with $\overline{\text{WDTOVF}}$ Signal

12.4.5 Internal Reset in Watchdog Timer Mode

If the RSTE bit is cleared to 0 in watchdog timer mode, the chip will not reset internally when a WTCNT overflow occurs, but WTCNT and WTCSR in the WDT will reset.

DataSheet4U.com

DataSheet4U.com

et4U.com

DataShee

DataSheet4U.com

www.DataSheet4U.com

Section 13 Serial Communication Interface

13.1 Overview

The SH7604 has a serial communication interface (SCI) that supports both asynchronous and clocked synchronous serial communication. It also has a multiprocessor communication function for serial communication among two or more processors.

13.1.1 Features

Selection of asynchronous or clock synchronous as the serial communication mode

- Asynchronous mode:
 - Serial data communication is synchronized by the start-stop method in character units. The SCI can communicate with a universal asynchronous receiver/transmitter (UART), an asynchronous communication interface adapter (ACIA), or any other chip that employs standard asynchronous serial communication. It can also communicate with two or more other processors using the multiprocessor communication function. There are twelve selectable serial data communication formats.
 - Data length: seven or eight bits
 - Stop bit length: one or two bits
 - Parity: even, odd, or none
 - Multiprocessor bit: one or none
 - Receive error detection: parity, overrun, and framing errors
- Clocked synchronous mode:
 - Serial data communication is synchronized with a clock signal. The SCI can communicate with other chips having a clocked synchronous communication function. There is one serial data communication format.
 - Data length: eight bits
 - Receive error detection: overrun errors
- Full duplex communication. The transmitting and receiving sections are independent, so the SCI can transmit and receive simultaneously. Both sections use double buffering, so continuous data transfer is possible in both the transmit and receive directions.
- Built-in baud rate generator with selectable bit rates
- Internal or external transmit/receive clock source. Baud rate generator (internal) or SCK pin (external)
- Four types of interrupts. Transmit-data-empty, transmit-end, receive-data-full, and receive-error interrupts are requested independently. The transmit-data-empty and receive-data-full interrupts can start the direct memory access controller (DMAC) to transfer data.

Figure 13.1 shows a block diagram of the SCI.

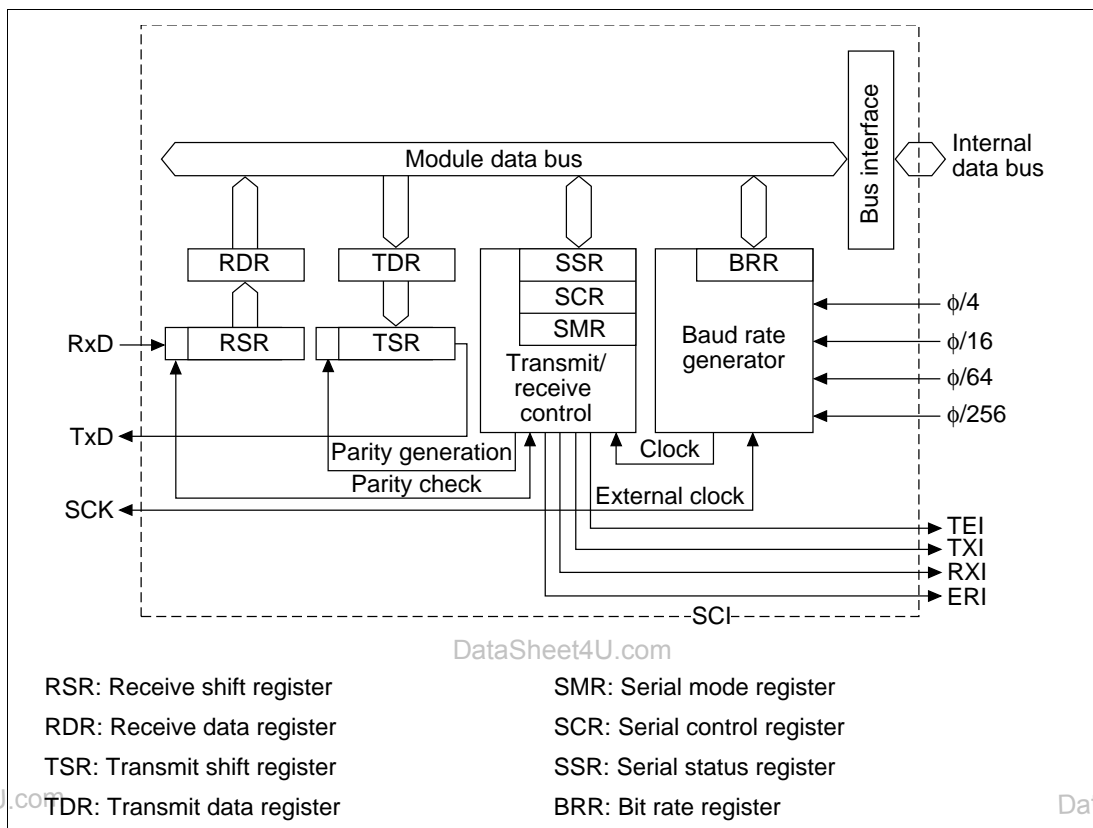

Figure 13.1 SCI Block Diagram

13.1.3 Pin Configuration

Table 13.1 summarizes the SCI pins.

Table 13.1 SCI Pins

Pin Name	Abbreviation	Input/Output	Function
Serial clock pin	SCK	Input/output	Clock input/output
Receive data pin	RxD	Input	Receive data input
Transmit data pin	TxD	Output	Transmit data output

13.1.4 Register Configuration

Table 13.2 summarizes the SCI internal registers. These registers select the communication mode (asynchronous or clock synchronous), specify the data format and bit rate, and control the transmitter and receiver sections.

Table 13.2 Registers

Name	Abbreviation	R/W	Initial Value	Address	Access size
Serial mode register	SMR	R/W	H'00	H'FFFFFFE00	8
Bit rate register	BRR	R/W	H'FF	H'FFFFFFE01	8
Serial control register	SCR	R/W	H'00	H'FFFFFFE02	8
Transmit data register	TDR	R/W	H'FF	H'FFFFFFE03	8
Serial status register	SSR	R/(W)*	H'84	H'FFFFFFE04	8
Receive data register	RDR	R	H'00	H'FFFFFFE05	8

Note: The only value that can be written is a 0 to clear the flags.

13.2 Register Descriptions

13.2.1 Receive Shift Register (RSR)

DataSheet4U.com

The receive shift register (RSR) receives serial data. Data input at the RxD pin is loaded into RSR in the order received, LSB (bit 0) first, converting the data to parallel form. When one byte has been received, it is automatically transferred to RDR. The CPU cannot read or write to RSR directly.

Bit:	7	6	5	4	3	2	1	0
Bit name:								
R/W:	—	—	—	—	—	—	—	—

13.2.2 Receive Data Register (RDR)

The receive data register (RDR) stores serial receive data. The SCI completes the reception of one byte of serial data by moving the received data from the receive shift register (RSR) into RDR for storage. RSR is then ready to receive the next data. This double buffering allows the SCI to receive data continuously.

The CPU can read but not write to RDR. RDR is initialized to H'00 by a reset and in standby and module standby mode.

www.DataSheet4U.com

Bit:	7	6	5	4	3	2	1	0
Bit name:								
Initial value:	0	0	0	0	0	0	0	0
R/W:	R	R	R	R	R	R	R	R

13.2.3 Transmit Shift Register (TSR)

The transmit shift register (TSR) transmits serial data. The SCI loads transmit data from the transmit data register (TDR) into TSR, then transmits the data serially from the TxD pin, LSB (bit 0) first. After transmitting one data byte, the SCI automatically loads the next transmit data from TDR into TSR and starts transmitting again. If the TDRE bit in SSR is 1, however, the SCI does not load the TDR contents into TSR. The CPU cannot read or write to TSR directly.

Bit:	7	6	5	4	3	2	1	0
Bit name:								
R/W:	—	—	—	—	—	—	—	—

13.2.4 Transmit Data Register (TDR)

The transmit data register (TDR) is an 8-bit register that stores data for serial transmission. When the SCI detects that the transmit shift register (TSR) is empty, it moves transmit data written in TDR into TSR and starts serial transmission. Continuous serial transmission is possible by writing the next transmit data in TDR during serial transmission from TSR.

The CPU can always read and write to TDR. TDR is initialized to H'FF by a reset and in standby and module standby mode.

Bit:	7	6	5	4	3	2	1	0
Bit name:								
Initial value:	1	1	1	1	1	1	1	1
R/W:	R/W	R/W	R/W	R/W	R/W	R/W	R/W	R/W

13.2.5 Serial Mode Register (SMR)

The serial mode register (SMR) is an 8-bit register that specifies the SCI serial communication format and selects the clock source for the baud rate generator.

The CPU can always read and write to SMR. SMR is initialized to H'00 by a reset and in standby and module standby mode.

Bit:	7	6	5	4	3	2	1	0
Bit name:	C/\overline{A}	CHR	PE	O/\overline{E}	STOP	MP	CKS1	CKS0
Initial value:	0	0	0	0	0	0	0	0
R/W:	R/W	R/W	R/W	R/W	R/W	R/W	R/W	R/W

- Bit 7—Communication Mode (C/\overline{A}): Selects whether the SCI operates in asynchronous or clocked synchronous mode.

Bit 7: C/\overline{A}	Description
0	Asynchronous mode (Initial value)
1	Clocked synchronous mode

- Bit 6—Character Length (CHR): Selects 7-bit or 8-bit data in asynchronous mode. In clocked synchronous mode, the data length is always eight bits, regardless of the CHR setting.

Bit 6: CHR	Description
0	8-bit data (Initial value)
1	7-bit data. (When 7-bit data is selected, the MSB (bit 7) of the transmit data register is not transmitted.)

- Bit 5—Parity Enable (PE): Selects whether to add a parity bit to transmit data and to check the parity of receive data, in asynchronous mode. In clocked synchronous mode, a parity bit is neither added nor checked, regardless of the PE setting.

Bit 5: PE	Description
0	Parity bit not added or checked (Initial value)
1	Parity bit added and checked. When PE is set to 1, an even or odd parity bit is added to transmit data, depending on the parity mode (O/\overline{E}) setting. Receive data parity is checked according to the even/odd (O/\overline{E}) mode setting.

- Bit 4—Parity Mode (O/\overline{E}): Selects even or odd parity when parity bits are added and checked. The O/\overline{E} setting is used only in asynchronous mode and only when the parity enable bit (PE) is set to 1 to enable parity addition and checking. The O/\overline{E} setting is ignored in clocked synchronous mode, and in asynchronous mode when parity addition and checking is disabled.

Bit 4: O/E	Description
0	Even parity (Initial value) If even parity is selected, the parity bit is added to transmit data to make an even number of 1s in the transmitted character and parity bit combined. Receive data is checked to see if it has an even number of 1s in the received character and parity bit combined.
1	Odd parity If odd parity is selected, the parity bit is added to transmit data to make an odd number of 1s in the transmitted character and parity bit combined. Receive data is checked to see if it has an odd number of 1s in the received character and parity bit combined.

- Bit 3—Stop Bit Length (STOP): Selects one or two bits as the stop bit length in asynchronous mode. This setting is used only in asynchronous mode. It is ignored in clocked synchronous mode because no stop bits are added.
- In receiving, only the first stop bit is checked, regardless of the STOP bit setting. If the second stop bit is 1, it is treated as a stop bit, but if the second stop bit is 0, it is treated as the start bit of the next incoming character.

Bit 3: STOP	Description
0	One stop bit (Initial value) In transmitting, a single 1-bit is added at the end of each transmitted character
1	Two stop bits In transmitting, two 1-bits are added at the end of each transmitted character

- Bit 2—Multiprocessor Mode (MP): Selects multiprocessor format. When multiprocessor format is selected, settings of the parity enable (PE) and parity mode (O/E) bits are ignored. The MP bit setting is used only in asynchronous mode; it is ignored in clocked synchronous mode. For the multiprocessor communication function, see section 13.3.3, Multiprocessor Communication.

Bit 2: MP	Description
0	Multiprocessor function disabled (Initial value)
1	Multiprocessor format selected

- Bits 1 and 0—Clock Select 1 and 0 (CKS1 and CKS0): These bits select the internal clock source of the built-in baud rate generator. Four clock sources are available. $\phi/4$, $\phi/16$, $\phi/64$ and $\phi/256$. For further information on the clock source, bit rate register settings, and baud rate, see section 13.2.8, Bit Rate Register.

Bit 1: CKS1	Bit 0: CKS0	Description
0	0	$\phi/4$ (Initial value)
	1	$\phi/16$
1	0	$\phi/64$
	1	$\phi/256$

13.2.6 Serial Control Register (SCR)

The serial control register (SCR) operates the SCI transmitter/receiver, selects the serial clock output in asynchronous mode, enables/disables interrupts, and selects the transmit/receive clock source. The CPU can always read and write to SCR. SCR is initialized to H'00 by a reset and in standby and module standby modes.

Bit:	7	6	5	4	3	2	1	0
Bit name:	TIE	RIE	TE	RE	MPIE	TEIE	CKE1	CKE0
Initial value:	0	0	0	0	0	0	0	0
R/W:	R/W	R/W	R/W	R/W	R/W	R/W	R/W	R/W

- Bit 7—Transmit Interrupt Enable (TIE): Enables or disables the transmit-data-empty interrupt (TXI) requested when the transmit data register empty bit (TDRE) in the serial status register (SSR) is set to 1 due to transfer of serial transmit data from TDR to TSR.

Bit 7: TIE	Description
0	Transmit-data-empty interrupt request (TXI) is disabled (Initial value) The TXI interrupt request can be cleared by reading TDRE after it has been set to 1, then clearing TDRE to 0, or by clearing TIE to 0.
1	Transmit-data-empty interrupt request (TXI) is enabled

- Bit 6—Receive Interrupt Enable (RIE): Enables or disables the receive-data-full interrupt (RXI) requested when the receive data register full bit (RDRF) in the serial status register (SSR) is set to 1 due to transfer of serial receive data from RSR to RDR. It also enables or disables receive-error interrupt (ERI) requests.

Bit 6: RIE	Description
0	Receive-data-full interrupt (RXI) and receive-error interrupt (ERI) requests are disabled (Initial value) RXI and ERI interrupt requests can be cleared by reading the RDRF flag or error flag (FER, PER, or ORER) after it has been set to 1, then clearing the flag to 0, or by clearing RIE to 0.
1	Receive-data-full interrupt (RXI) and receive-error interrupt (ERI) requests are enabled

- Bit 5—Transmit Enable (TE): Enables or disables the SCI serial transmitter.

Bit 5: TE	Description
0	Transmitter disabled (Initial value) The transmit data register empty bit (TDRE) in the serial status register (SSR) is locked at 1
1	Transmitter enabled Serial transmission starts when the transmit data register empty (TDRE) bit in the serial status register (SSR) is cleared to 0 after writing of transmit data into TDR. Select the transmit format in SMR before setting TE to 1.

- Bit 4—Receive Enable (RE): Enables or disables the SCI serial receiver.

Bit 4: RE	Description
0	Receiver disabled (Initial value) Clearing RE to 0 does not affect the receive flags (RDRF, FER, PER, ORER). These flags retain their previous values.
1	Receiver enabled Serial reception starts when a start bit is detected in asynchronous mode, or synchronous clock input is detected in clocked synchronous mode. Select the receive format in SMR before setting RE to 1.

- Bit 3—Multiprocessor Interrupt Enable (MPIE): Enables or disables multiprocessor interrupts. The MPIE setting is used only in asynchronous mode, and only if the multiprocessor mode bit (MP) in the serial mode register (SMR) is set to 1 during reception. The MPIE setting is ignored in clocked synchronous mode or when the MP bit is cleared to 0.

Bit 3: MPIE	Description
0	Multiprocessor interrupts are disabled (normal receive operation) (Initial value) MPIE is cleared to 0 when MPIE is cleared to 0, or the multiprocessor bit (MPB) is set to 1 in receive data.
1	Multiprocessor interrupts are enabled Receive-data-full interrupt requests (RXI), receive-error interrupt requests (ERI), and setting of the RDRF, FER, and ORER status flags in the serial status register (SSR) are disabled until the multiprocessor bit is set to 1. The SCI does not transfer receive data from RSR to RDR, does not detect receive errors, and does not set the RDRF, FER, and ORER flags in the serial status register (SSR). When it receives data that includes MPB = 1, MPB is set to 1 in SSR, and the SCI automatically clears MPIE to 0, generates RXI and ERI interrupts (if the TIE and RIE bits in SCR are set to 1), and enables the FER and ORER bits to be set.

- Bit 2—Transmit-End Interrupt Enable (TEIE): Enables or disables the transmit-end interrupt (TEI) requested if TDR does not contain new transmit data when the MSB is transmitted.

Bit 2: TEIE	Description
0	Transmit-end interrupt (TEI) requests are disabled* (Initial value)
1	Transmit-end interrupt (TEI) requests are enabled*

Note: The TEI request can be cleared by reading the TDRE bit in the serial status register (SSR) after it has been set to 1, then clearing TDRE to 0; by clearing the transmit end (TEND) bit to 0; or by clearing the TEIE bit to 0.

- Bits 1 and 0—Clock Enable 1 and 0 (CKE1 and CKE0): These bits select the SCI clock source and enable or disable clock output from the SCK pin. Depending on the combination of CKE1 and CKE0, the SCK pin can be used for general-purpose input/output, serial clock output, or serial clock input.

The CKE0 setting is valid only in asynchronous mode, and only when the SCI is internally clocked (CKE1 = 0). The CKE0 setting is ignored in clocked synchronous mode, or when an external clock source is selected (CKE1 = 1). Select the SCI operating mode in the serial mode register (SMR) before setting CKE1 and CKE0. For further details on selection of the SCI clock source, see table 13.9 in section 13.3, Operation.

Bit 1: Bit 0:**CKE1 CKE0 Description**

0	0	Asynchronous mode	Internal clock, SCK pin used for input pin (input signal is ignored or output pin output level is undefined) ^{*1}
		Clocked synchronous mode	Internal clock, SCK pin used for synchronous clock output ^{*1}
0	1	Asynchronous mode	Internal clock, SCK pin used for clock output ^{*2}
		Clocked synchronous mode	Internal clock, SCK pin used for synchronous clock output
1	0	Asynchronous mode	External clock, SCK pin used for clock input ^{*3}
		Clocked synchronous mode	External clock, SCK pin used for synchronous clock input
1	1	Asynchronous mode	External clock, SCK pin used for clock input ^{*3}
		Clocked synchronous mode	External clock, SCK pin used for synchronous clock input

Notes: 1. Initial value

2. The output clock frequency is the same as the bit rate.

3. The input clock frequency is 16 times the bit rate.

13.2.7 Serial Status Register (SSR)

DataSheet4U.com

The serial status register (SSR) is an 8-bit register containing multiprocessor bit values, and status flags that indicate the SCI operating status.

The CPU can always read and write to SSR, but cannot write 1 in the status flags (TDRE, RDRF, ORER, PER, and FER). These flags can be cleared to 0 only if they have first been read (after being set to 1). Bits 2 (TEND) and 1 (MPB) are read-only bits that cannot be written. SSR is initialized to H'84 by a reset and in standby and module standby mode.

Bit:	7	6	5	4	3	2	1	0
Bit name:	TDRE	RDRF	ORER	FER	PER	TEND	MPB	MPBT
Initial value:	1	0	0	0	0	1	0	0
R/W:	R/(W)*	R/(W)*	R/(W)*	R/(W)*	R/(W)*	R	R	R/W

Note: The only value that can be written is a 0 to clear the flag.

- Bit 7—Transmit Data Register Empty (TDRE): Indicates that the SCI has loaded transmit data from TDR into TSR and new serial transmit data can be written in TDR.

Bit 7: TDRE	Description
0	TDR contains valid transmit data TDRE is cleared to 0 when software reads TDRE after it has been set to 1, then writes 0 in TDRE, or the DMAC writes data in TDR.
1	TDR does not contain valid transmit data (Initial value) TDRE is set to 1 when the chip is reset or enters standby mode, the TE bit in the serial control register (SCR) is cleared to 0, or TDR contents are loaded into TSR, so new data can be written in TDR.

- Bit 6—Receive Data Register Full (RDRF): Indicates that RDR contains received data.

Bit 6: RDRF	Description
0	RDR does not contain valid receive data (Initial value) RDRF is cleared to 0 when the chip is reset or enters standby mode, software reads RDRF after it has been set to 1, then writes 0 in RDRF, or the DMAC reads data from RDR.
1	RDR contains valid received data RDRF is set to 1 when serial data is received normally and transferred from RSR to RDR.

Note: RDR and RDRF are not affected by detection of receive errors or by clearing of the RE bit to 0 in the serial control register. They retain their previous contents. If RDRF is still set to 1 when reception of the next data ends, an overrun error (ORER) occurs and the received data is lost.

- Bit 5—Overrun Error (ORER): Indicates that data reception ended abnormally due to an overrun error.

Bit 5: ORER	Description
0	Receiving is in progress or has ended normally*1 (Initial value) ORER is cleared to 0 when the chip is reset or enters standby mode, or software reads ORER after it has been set to 1, then writes 0 in ORER.
1	A receive overrun error occurred*2 ORER is set to 1 if reception of the next serial data ends when RDRF is set to 1.

- Notes:
1. Clearing the RE bit to 0 in the serial control register does not affect the ORER bit, which retains its previous value.
 2. RDR continues to hold the data received before the overrun error, so subsequent receive data is lost. Serial receiving cannot continue while ORER is set to 1. In clocked synchronous mode, serial transmitting is disabled.

- Bit 4—Framing Error (FER): Indicates that data reception ended abnormally due to a framing error in asynchronous mode.

Bit 4: FER	Description
0	<p>Receiving is in progress or has ended normally (Initial value)</p> <p>Clearing the RE bit to 0 in the serial control register does not affect the FER bit, which retains its previous value.</p> <p>FER is cleared to 0 when the chip is reset or enters standby mode, or software reads FER after it has been set to 1, then writes 0 in FER.</p>
1	<p>A receive framing error occurred</p> <p>When the stop bit length is two bits, only the first bit is checked. The second stop bit is not checked. When a framing error occurs, the SCI transfers the receive data into RDR but does not set RDRF. Serial receiving cannot continue while FER is set to 1. In clocked synchronous mode, serial transmitting is also disabled.</p> <p>FER is set to 1 if the stop bit at the end of receive data is checked and found to be 0.</p>

- Bit 3—Parity Error (PER): Indicates that data reception (with parity) ended abnormally due to a parity error in asynchronous mode.

Bit 3: PER	Description
0	<p>Receiving is in progress or has ended normally (Initial value)</p> <p>Clearing the RE bit to 0 in the serial control register does not affect the PER bit, which retains its previous value.</p> <p>PER is cleared to 0 when the chip is reset or enters standby mode, or software reads PER after it has been set to 1, then writes 0 in PER.</p>
1	<p>A receive parity error occurred</p> <p>When a parity error occurs, the SCI transfers the receive data into RDR but does not RDRF. Serial receiving cannot continue while PER is set to 1. In clocked synchronous mode, serial transmitting is also disabled.</p> <p>PER is set to 1 if the number of 1s in receive data, including the parity bit, does not match the even or odd parity setting of the parity mode bit (O/\bar{E}) in the serial mode register (SMR).</p>

- **Bit 2—Transmit End (TEND):** Indicates that when the last bit of a serial character was transmitted, TDR did not contain valid data, so transmission has ended. TEND is a read-only bit and cannot be written.

Bit 2: TEND	Description
0	Transmission is in progress TEND is cleared to 0 when software reads TDRE after it has been set to 1, then writes 0 in TDRE, or the DMAC writes data in TDR.
1	End of transmission (Initial value) TEND is set to 1 when the chip is reset or enters standby mode, TE is cleared to 0 in the serial control register (SCR), or TDRE is 1 when the last bit of a one-byte serial character is transmitted.

- **Bit 1—Multiprocessor Bit (MPB):** Stores the value of the multiprocessor bit in receive data when a multiprocessor format is selected for receiving in asynchronous mode. MPB is a read-only bit and cannot be written.

Bit 1: MPB	Description
0	Multiprocessor bit value in receive data is 0 (Initial value) If RE is cleared to 0 when a multiprocessor format is selected, MPB retains its previous value.
1	Multiprocessor bit value in receive data is 1

- **Bit 0—Multiprocessor Bit Transfer (MPBT):** Stores the value of the multiprocessor bit added to transmit data when a multiprocessor format is selected for transmitting in asynchronous mode. The MPBT setting is ignored in clocked synchronous mode, when a multiprocessor format is not selected, or when the SCI is not transmitting.

Bit 0: MPBT	Description
0	Multiprocessor bit value in transmit data is 0 (Initial value)
1	Multiprocessor bit value in transmit data is 1

13.2.8 Bit Rate Register (BRR)

The bit rate register (BRR) is an 8-bit register that, together with the baud rate generator clock source selected by the CKS1 and CKS0 bits in the serial mode register (SMR), determines the serial transmit/receive bit rate.

The CPU can always read and write to BRR. BRR is initialized to H'FF by a reset and in standby mode.

Bit:	7	6	5	4	3	2	1	0
Bit name:								
Initial value:	1	1	1	1	1	1	1	1
R/W:	R/W	R/W	R/W	R/W	R/W	R/W	R/W	R/W

Table 13.3 shows examples of BRR settings in asynchronous mode; table 13.4 shows examples of BRR settings in clocked synchronous mode.

DataSheet4U.com

et4U.com

DataShee

DataSheet4U.com

www.DataSheet4U.com

Table 13.3 Bit Rates and BRR Settings in Asynchronous Mode

Bit Rate (bits/s)	ϕ (MHz)											
	4			4.9152			8			9.8304		
	n	N	Error (%)	n	N	Error (%)	n	N	Error (%)	n	N	Error (%)
110	1	70	0.03	1	86	0.31	1	141	0.03	1	174	-0.26
150	0	207	0.16	0	255	0.00	1	103	0.16	1	127	0.00
300	0	103	0.16	0	127	0.00	0	207	0.16	0	255	0.00
600	0	51	0.16	0	63	0.00	0	103	0.16	0	127	0.00
1200	0	25	0.16	0	31	0.00	0	51	0.16	0	63	0.00
2400	0	12	0.16	0	15	0.00	0	25	0.16	0	31	0.00
4800	—	—	—	0	7	0.00	0	12	0.16	0	15	0.00
9600	—	—	—	0	3	0.00	—	—	—	0	7	0.00
19200	—	—	—	0	1	0.00	—	—	—	0	3	0.00
31250	0	0	0.00	—	—	—	0	1	0.00	—	—	—
38400	—	—	—	0	0	0.00	—	—	—	0	1	0.00

Bit Rate (bits/s)	ϕ (MHz)											
	12			14.7456			16			19.6608		
	n	N	Error (%)	n	N	Error (%)	n	N	Error (%)	n	N	Error (%)
110	1	212	0.03	2	64	0.70	2	70	0.03	2	86	0.31
150	1	155	0.16	1	191	0.00	1	207	0.16	1	255	0.00
300	1	77	0.16	1	95	0.00	1	103	0.16	1	127	0.00
600	0	155	0.16	0	191	0.00	0	207	0.16	0	255	0.00
1200	0	77	0.16	0	95	0.00	0	103	0.16	0	127	0.00
2400	0	38	0.16	0	47	0.00	0	51	0.16	0	63	0.00
4800	0	19	-2.34	0	23	0.00	0	25	0.16	0	31	0.00
9600	0	9	-2.34	0	11	0.00	0	12	0.16	0	15	0.00
19200	0	4	-2.34	0	5	0.00	—	—	—	0	7	0.00
31250	0	2	0.00	—	—	—	0	3	0.00	0	4	-1.70
38400	—	—	—	0	2	0.00	—	—	—	0	3	0.00

Table 13.3 Bit Rates and BRR Settings in Asynchronous Mode (cont)

Bit Rate (bits/s)	ϕ (MHz)											
	20			24			24.576			28.7		
	n	N	Error (%)	n	N	Error (%)	n	N	Error (%)	n	N	Error (%)
110	2	88	-0.25	2	106	-0.44	2	108	0.08	2	126	0.31
150	2	64	0.16	2	77	0.16	2	79	0.00	2	92	0.46
300	1	129	0.16	1	155	0.16	1	159	0.00	1	186	-0.08
600	1	64	0.16	1	77	0.16	1	79	0.00	1	92	0.46
1200	0	129	0.16	0	155	0.16	0	159	0.00	0	186	-0.08
2400	0	64	0.16	0	77	0.16	0	79	0.00	0	92	0.46
4800	0	32	-1.36	0	38	0.16	0	39	0.00	0	46	-0.61
9600	0	15	1.73	0	19	-2.34	0	19	0.00	0	22	1.55
19200	0	7	1.73	0	9	-2.34	0	9	0.00	0	11	-2.68
31250	0	4	0.00	0	5	0.00	0	5	2.40	0	6	2.50
38400	0	3	1.73	0	4	-2.34	0	4	0.00	0	5	-2.68

DataSheet4U.com

et4U.com

DataShee

DataSheet4U.com

www.DataSheet4U.com

Table 13.4 Bit Rates and BRR Settings in Clocked Synchronous Mode

Bit Rate (bits/s)	ϕ (MHz)							
	4		8		16		28.7	
	n	N	n	N	n	N	n	N
110	2	141	3	70	3	141	3	254
250	1	249	2	124	2	249	3	111
500	1	124	1	249	2	124	2	223
1k	0	249	1	124	1	249	2	111
2.5k	0	99	0	199	1	99	1	178
5k	0	49	0	99	0	199	1	89
10k	0	24	0	49	0	99	0	178
25k	0	9	0	19	0	39	0	71
50k	0	4	0	9	0	19	0	35
100k	—	—	0	4	0	9	0	17
250k	0	0*	0	1	0	3	—	—
500k			0	0*	0	1	—	—
1M					0	0*	—	—

Note: Settings with an error of 1% or less are recommended.

Explanation of symbols:

Blank: No setting possible

—: Setting possible, but error occurs

*: Continuous transmission/reception not possible

The BRR setting is calculated as follows:

Asynchronous mode:

$$N = \frac{\phi}{256 \times 2^{2n-1} \times B} \times 10^6 - 1$$

Clocked synchronous mode:

$$N = \frac{\phi}{32 \times 2^{2n-1} \times B} \times 10^6 - 1$$

B: Bit rate (bit/s)

N: BRR setting for baud rate generator ($0 \leq N \leq 255$)

f: Operating frequency (MHz)

n: Baud rate generator clock source ($n = 0, 1, 2, 3$) (For the clock sources and values of n, see table 13.6.)

Table 13.5 SMR Settings

n	Clock Source	SMR Settings	
		CKS1	CKS0
0	$\phi/4$	0	0
1	$\phi/16$	0	1
2	$\phi/164$	1	0
3	$\phi/256$	1	1

The bit rate error for asynchronous mode is given by the following equation:

$$\text{Error (\%)} = \left(\frac{\phi \times 10^6}{(N + 1) \times B \times 256 \times 2^{2n-1}} - 1 \right) \times 100$$

Table 13.6 shows the maximum bit rates in asynchronous mode when the baud rate generator is being used. Tables 13.7 and 13.8 show the maximum rates for external clock input.

Table 13.6 Maximum Bit Rates for Various Frequencies with Baud Rate Generator (Asynchronous Mode)

ϕ (MHz)	Maximum Bit Rate (bits/s)	Settings	
		n	N
4	31250	0	0
4.9152	38400	0	0
8	62500	0	0
9.8304	76800	0	0
12	93750	0	0
14.7456	115200	0	0
16	125000	0	0
19.6608	153600	0	0
20	156250	0	0
24	187500	0	0
24.576	192000	0	0
28.7	224218	0	0

Table 13.7 Maximum Bit Rates with External Clock Input (Asynchronous Mode)

ϕ (MHz)	External Input Clock (MHz)	Maximum Bit Rate (bits/s)
4	0.2500	15625
4.9152	0.3072	19200
8	0.5000	31250
9.8304	0.6144	38400
12	0.7500	46875
14.7456	0.9216	57600
16	1.0000	62500
19.6608	1.2288	76800
20	1.2500	78125
24	1.5000	93750
24.576	1.5360	96000
28.7	1.79375	112109

Table 13.8 Maximum Bit Rates with External Clock Input (Clocked Synchronous Mode)

ϕ (MHz)	External Input Clock (MHz)	Maximum Bit Rate (bits/s)
8	0.3333	333333.3
16	0.6667	666666.7
24	1.0000	1000000.0
28.7	1.1958	1195833.3

13.3.1 Overview

For serial communication, the SCI has an asynchronous mode in which characters are synchronized individually, and a clocked synchronous mode in which communication is synchronized with clock pulses. Asynchronous/clocked synchronous mode and the communication format are selected in the serial mode register (SMR), as shown in table 13.9. The SCI clock source is selected by the C/\bar{A} bit in the serial mode register (SMR) and the CKE1 and CKE0 bits in the serial control register (SCR), as shown in table 13.10.

Asynchronous Mode:

- Data length is selectable. seven or eight bits.
- Parity and multiprocessor bits are selectable, as is the stop bit length (one or two bits). The preceding selections constitute the communication format and character length.
- In receiving, it is possible to detect framing errors, parity errors, overrun errors, and the break state.
- An internal or external clock can be selected as the SCI clock source.
 - When an internal clock is selected, the SCI operates using the built-in baud rate generator, and can output a serial clock signal with a frequency matching the bit rate.
 - When an external clock is selected, the external clock input must have a frequency 16 times the bit rate. (The built-in baud rate generator is not used.)

Clocked Synchronous Mode:

- The communication format has a fixed eight-bit data length.
- In receiving, it is possible to detect overrun errors.
- An internal or external clock can be selected as the SCI clock source.
 - When an internal clock is selected, the SCI operates using the built-in baud rate generator, and outputs a synchronous clock signal to external devices.
 - When an external clock is selected, the SCI operates on the input synchronous clock. The built-in baud rate generator is not used.

Table 13.9 Serial Mode Register Settings and SCI Communication Formats

Mode	SMR Settings					SCI Communication Format			
	Bit 7 C/A	Bit 6 CHR	Bit 5 PE	Bit 2 MP	Bit 3 STOP	Data Length	Parity Bit	Multipro- cessor Bit	Stop Bit Length
Asynchronous	0	0	0	0	0	8-bit	Not set	Not set	1 bit
					1				2 bits
	1	0	1	0	0	7-bit	Not set	Set	1 bit
					1				2 bits
					0				1 bit
					1				2 bits
Asynchronous (multiprocessor format)	0	0	*	1	0	8-bit	Not set	Set	1 bit
					1				2 bits
	1	*	0	1	0	7-bit	Set	None	1 bit
					1				2 bits
Clocked synchronous	1	*	*	*	*	8-bit	Not set	Not set	None

Note: Asterisks (*) in the table indicate don't care bits.

Table 13.10 SMR and SCR Settings and SCI Clock Source Selection

Mode	SMR	SCR Settings		SCI Transmit/Receive Clock	
	Bit 7 C/A	Bit 1 CKE1	Bit 0 CKE0	Clock Source	SCK Pin Function
Asynchronous	0	0	0	Internal	SCI does not use the SCK pin
			1		Outputs a clock with frequency matching the bit rate
	1	0	0	External	Inputs a clock with frequency 16 times the bit rate
			1		
Clocked synch- ronous	1	0	0	Internal	Outputs the synchronous clock
			1		
	1	0	0	External	Inputs the synchronous clock
			1		

13.3.2 Operation in Asynchronous Mode

In asynchronous mode, each transmitted or received character begins with a start bit and ends with a stop bit. Serial communication is synchronized one character at a time.

The transmitting and receiving sections of the SCI are independent, so full duplex communication is possible. The transmitter and receiver are both double buffered, so data can be written and read while transmitting and receiving are in progress, enabling continuous transmitting and receiving.

Figure 13.2 shows the general format of asynchronous serial communication. In asynchronous serial communication, the communication line is normally held in the mark (high) state. The SCI monitors the line and starts serial communication when the line goes to the space (low) state, indicating a start bit. One serial character consists of a start bit (low), data (LSB first), parity bit (high or low), and stop bit (high), in that order.

When receiving in asynchronous mode, the SCI synchronizes on the falling edge of the start bit. The SCI samples each data bit on the eighth pulse of a clock with a frequency 16 times the bit rate. Receive data is latched at the center of each bit.

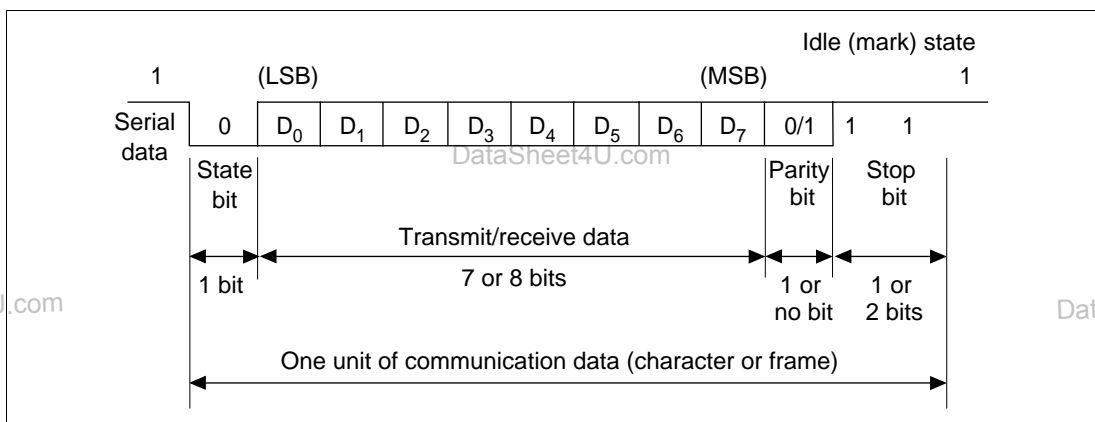

Figure 13.2 Example of Data Format in Asynchronous Communication (8-Bit Data with Parity and Two Stop Bits)

Transmit/Receive Formats. Table 13.11 shows the 12 communication formats that can be selected in asynchronous mode. The format is selected by settings in the serial mode register (SMR).

Table 13.11 Serial Communication Formats (Asynchronous Mode)

SMR Bits				Serial Transmit/Receive Format and Frame Length												
CHR	PE	MP	STOP	1	2	3	4	5	6	7	8	9	10	11	12	
0	0	0	0	START	8-bit data								STOP			
0	0	0	1	START	8-bit data								STOP	STOP		
0	1	0	0	START	8-bit data								P	STOP		
0	1	0	1	START	8-bit data								P	STOP	STOP	
1	0	0	0	START	7-bit data							STOP				
1	0	0	1	START	7-bit data							STOP	STOP			
1	1	0	0	START	7-bit data							P	STOP			
1	1	0	1	START	7-bit data							P	STOP	STOP		
0	—	1	0	START	8-bit data								MPB	STOP		
0	—	1	1	START	8-bit data								MPB	STOP	STOP	
1	—	1	0	START	7-bit data							MPB	STOP			
1	—	1	1	START	7-bit data							MPB	STOP	STOP		

—: Don't care bits.

START: Start bit

STOP: Stop bit

P: Parity bit

MPB: Multiprocessor bit

Clock: An internal clock generated by the built-in baud rate generator or an external clock input from the SCK pin can be selected as the SCI transmit/receive clock. The clock source is selected by the C/\bar{A} bit in the serial mode register (SMR) and bits CKE1 and CKE0 in the serial control register (SCR) (table 13.9).

When an external clock is input at the SCK pin, it must have a frequency equal to 16 times the desired bit rate.

When the SCI operates on an internal clock, it can output a clock signal at the SCK pin. The frequency of this output clock is equal to the bit rate. The phase is aligned as in figure 13.3 so that the rising edge of the clock occurs at the center of each transmit data bit.

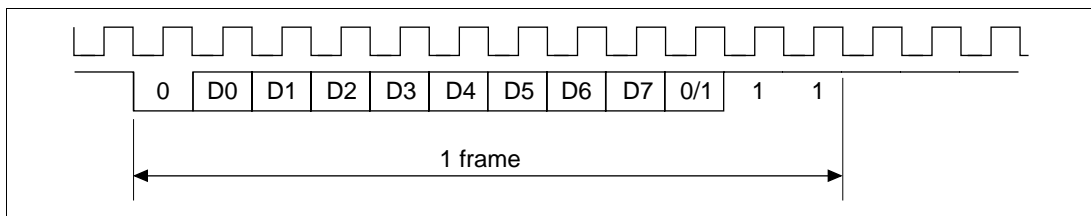

Figure 13.3 Output Clock and Serial Data Timing (Asynchronous Mode)

Transmitting and Receiving Data

SCI Initialization (Asynchronous Mode): Before transmitting or receiving, clear the TE and RE bits to 0 in the serial control register (SCR), then initialize the SCI as follows.

When changing the operation mode or communication format, always clear the TE and RE bits to 0 before following the procedure given below. Clearing TE to 0 sets TDRE to 1 and initializes the transmit shift register (TSR). Clearing RE to 0, however, does not initialize the RDRF, PER, FER, and ORER flags and receive data register (RDR), which retain their previous contents.

When an external clock is used, the clock should not be stopped during initialization or subsequent operation. SCI operation becomes unreliable if the clock is stopped.

Figure 13.4 shows a sample flowchart for initializing the SCI. The procedure for initializing the SCI is as follows:

1. Select the communication format in the serial mode register (SMR).
2. Write the value corresponding to the bit rate in the bit rate register (BRR) unless an external clock is used.
3. Select the clock source in the serial control register (SCR). Leave RIE, TIE, TEIE, MPIE, TE and RE cleared to 0. If clock output is selected in asynchronous mode, clock output starts immediately after the setting is made in SCR.

4. Wait for at least the interval required to transmit or receive one bit, then set TE or RE in the serial control register (SCR) to 1. Also set RIE, TIE, TEIE and MPIE as necessary. Setting TE or RE enables the SCI to use the TxD or RxD pin. The initial states are the mark state when transmitting, and the idle state when receiving (waiting for a start bit).

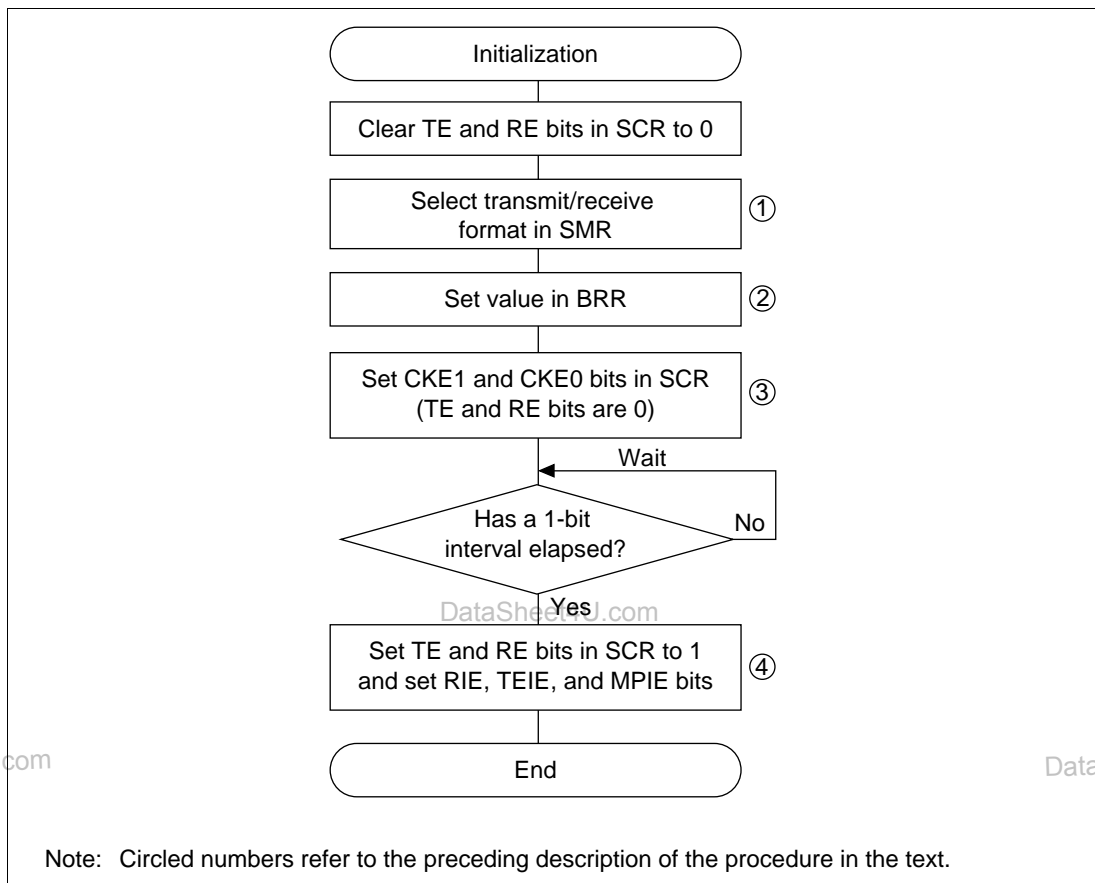

Figure 13.4 Sample Flowchart for SCI Initialization

Transmitting Serial Data (Asynchronous Mode): Figure 13.5 shows a sample flowchart for transmitting serial data. The procedure for transmitting serial data is as follows:

1. SCI status check and transmit data write: read the serial status register (SSR), check that the TDRE bit is 1, then write transmit data in the transmit data register (TDR) and clear TDRE to 0.
2. To continue transmitting serial data, read the TDRE bit to check whether it is safe to write (if it reads 1); if so, write data in TDR, then clear TDRE to 0. When the DMAC is started by a transmit-data-empty interrupt request (TXI) in order to write data in TDR, the TDRE bit is checked and cleared automatically.

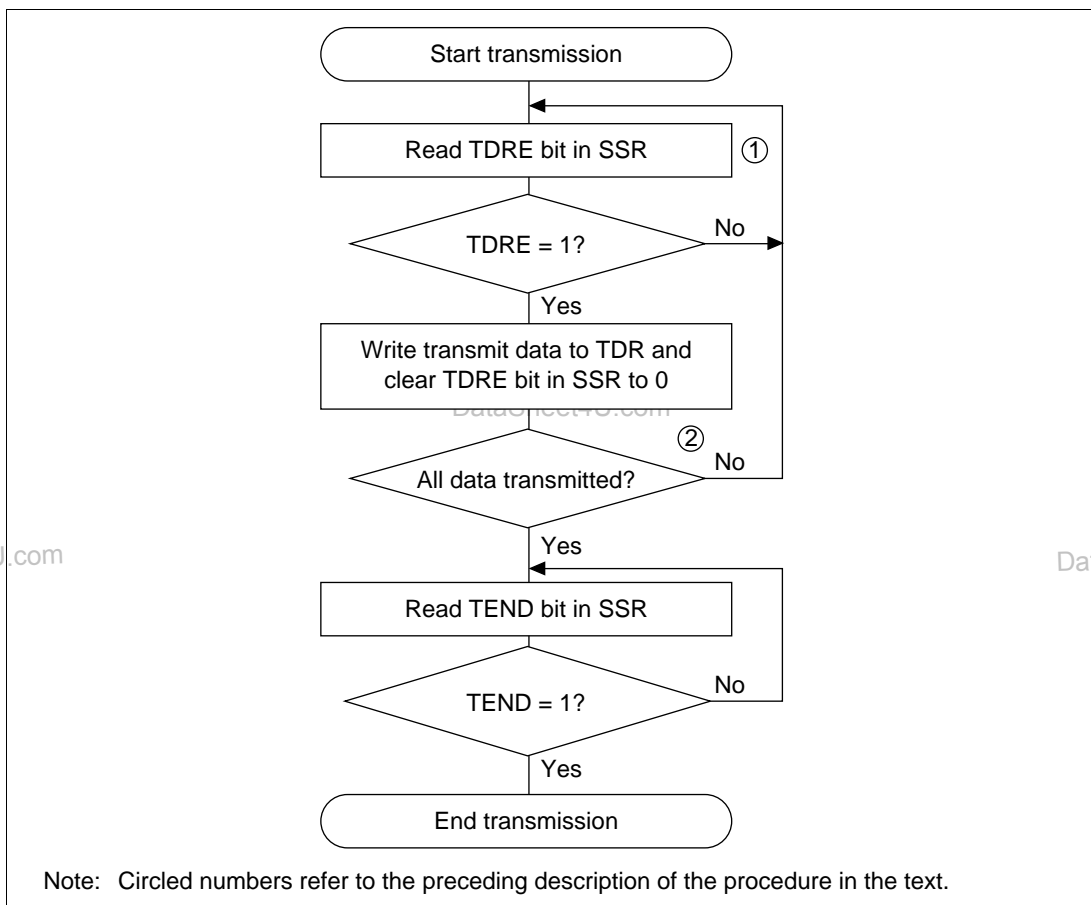

Figure 13.5 Sample Flowchart for Transmitting Serial Data

In transmitting serial data, the SCI operates as follows:

1. The SCI monitors the TDRE bit in SSR. When TDRE is cleared to 0, the SCI recognizes that the transmit data register (TDR) contains new data, and loads this data from TDR into the transmit shift register (TSR).
2. After loading the data from TDR into TSR, the SCI sets the TDRE bit to 1 and starts transmitting. If the transmit-data-empty interrupt enable bit (TIE) is set to 1 in SCR, the SCI requests a transmit-data-empty interrupt (TXI) at this time.

Serial transmit data is transmitted in the following order from the TxD pin:

- a. Start bit: one 0-bit is output.
 - b. Transmit data: seven or eight bits of data are output, LSB first.
 - c. Parity bit or multiprocessor bit: one parity bit (even or odd parity) or one multiprocessor bit is output. Formats in which neither a parity bit nor a multiprocessor bit is output can also be selected.
 - d. Stop bit: one or two 1-bits (stop bits) are output.
 - e. Mark state: output of 1-bits continues until the start bit of the next transmit data.
3. The SCI checks the TDRE bit when it outputs the stop bit. If TDRE is 0, the SCI loads new data from TDR into TSR, outputs the stop bit, then begins serial transmission of the next frame. If TDRE is 1, the SCI sets the TEND bit to 1 in SSR, outputs the stop bit, then continues output of 1-bits (mark state). If the transmit-end interrupt enable bit (TEIE) in SCR is set to 1, a transmit-end interrupt (TEI) is requested.

Figure 13.6 shows an example of SCI transmit operation in asynchronous mode.

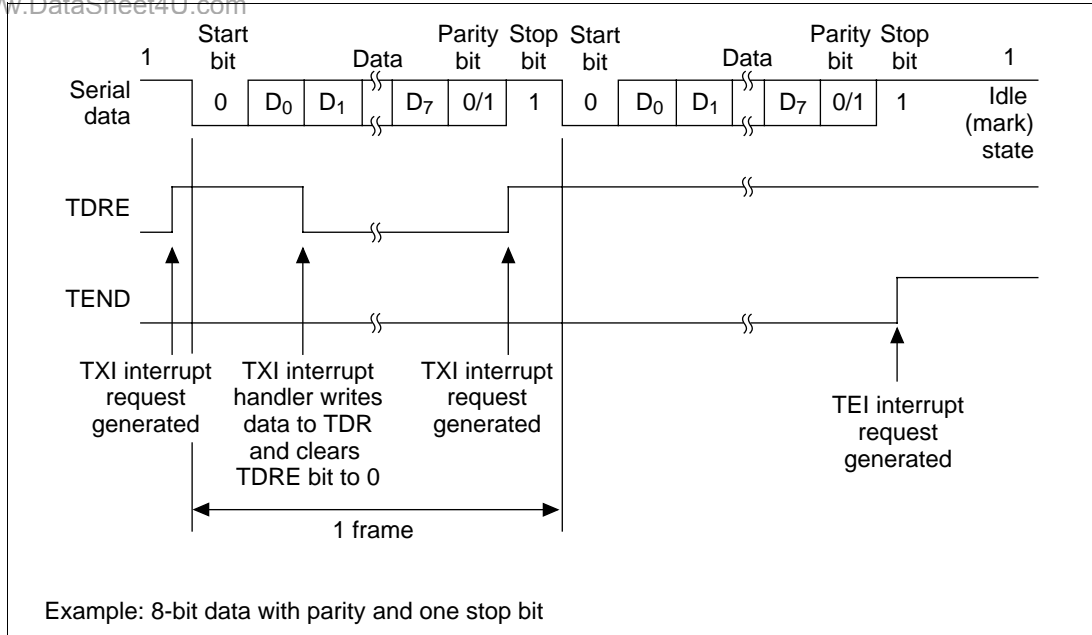
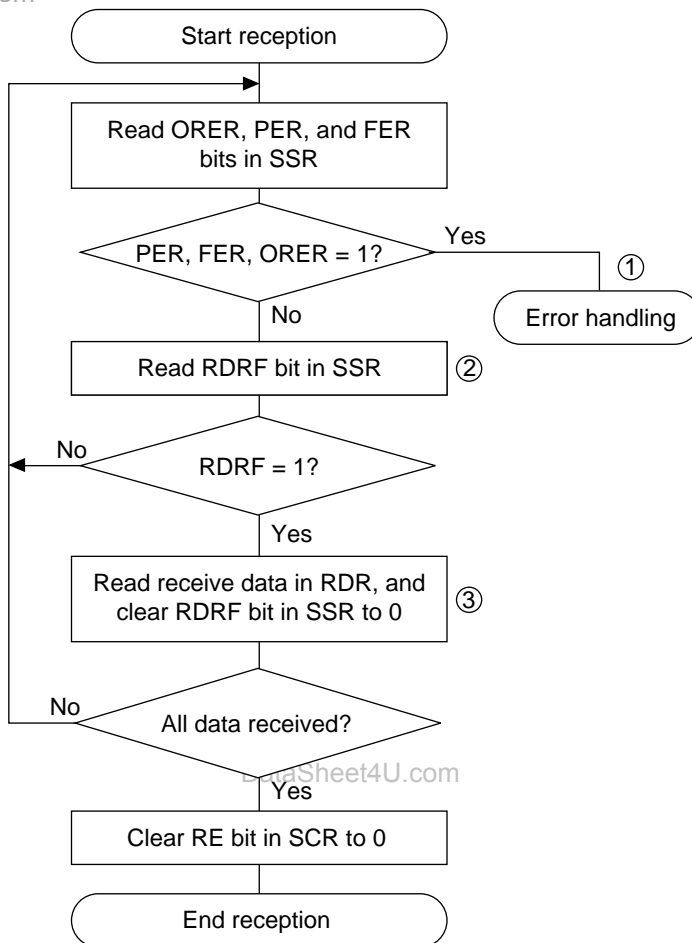

Figure 13.6 Example of SCI Transmit Operation in Asynchronous Mode (8-Bit Data with Parity and One Stop Bit)

Receiving Serial Data (Asynchronous Mode): Figure 13.7 shows a sample flowchart for receiving serial data. The procedure for receiving serial data is as follows:

1. Receive error handling: if a receive error occurs, read the ORER, PER and FER bits of the SSR to identify the error. After executing the necessary error handling, clear ORER, PER and FER all to 0. Receiving cannot resume if ORER, PER or FER remain set to 1.
2. SCI status check and receive-data read: read the serial status register (SSR), check that RDRF is set to 1, then read receive data from the receive data register (RDR) and clear RDRF to 0. The RXI interrupt can also be used to determine if the RDRF bit has changed from 0 to 1.
3. To continue receiving serial data: read the RDRF and RDR bits and clear RDRF to 0 before the stop bit of the current frame is received. If the DMAC is started by a receive-data-full interrupt (RXI) to read RDR, the RDRF bit is cleared automatically so this step is unnecessary.



Note: Circled numbers refer to the preceding description of the procedure in the text.

Figure 13.7 Sample Flowchart for Receiving Serial Data

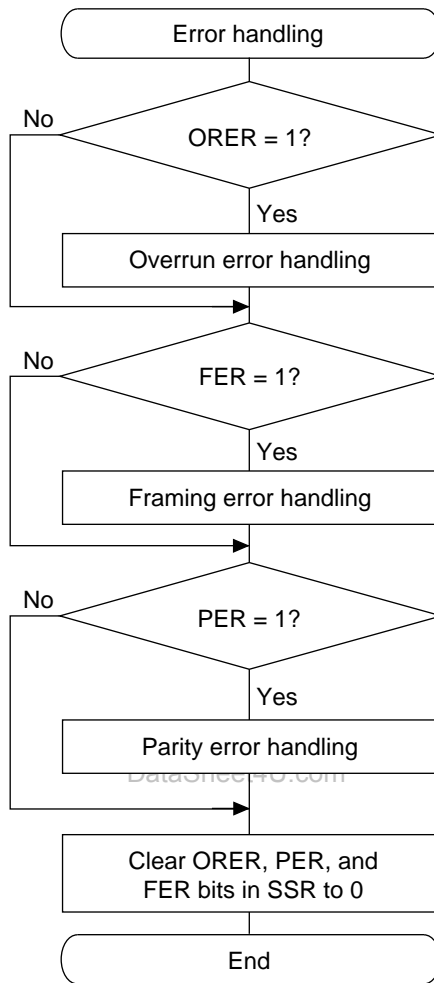

Note: Circled numbers refer to the preceding description of the procedure in the text.

Figure 13.7 Sample Flowchart for Receiving Serial Data (cont)

In receiving, the SCI operates as follows:

1. The SCI monitors the receive data line. When it detects a start bit (0), the SCI synchronizes internally and starts receiving.
2. Receive data is shifted into RSR in order from LSB to MSB.
3. The parity bit and stop bit are received. After receiving these bits, the SCI makes the following checks:
 - a. Parity check: the number of 1s in the receive data must match the even or odd parity setting of the O/\bar{E} bit in SMR.
 - b. Stop bit check: the stop bit value must be 1. If there are two stop bits, only the first stop bit is checked.
 - c. Status check: RDRF must be 0 so that receive data can be loaded from RSR into RDR.

If these checks all pass, the SCI sets RDRF to 1 and stores the received data in RDR. If one of the checks fails (receive error), the SCI operates as indicated in table 13.11.

Note: When a receive error flag is set, further receiving is disabled. In reception, the RDRF bit is not set to 1. Be sure to clear the error flags.

4. After setting RDRF to 1, if the receive-data-full interrupt enable bit (RIE) is set to 1 in SCR, the SCI requests a receive-data-full interrupt (RXI). If one of the error flags (ORER, PER, or FER) is set to 1 and the receive-data-full interrupt enable bit (RIE) in SCR is also set to 1, the SCI requests a receive-error interrupt (ERI).

Figure 13.8 shows an example of SCI receive operation in asynchronous mode.

Table 13.12 Receive Error Conditions and SCI Operation

Receive Error	Abbreviation	Condition	Data Transfer
Overrun error	ORER	Receiving of next data ends while RDRF is still set to 1 in SSR	Receive data not loaded from RSR into RDR
Framing error	FER	Stop bit is 0	Receive data loaded from RSR into RDR
Parity error	PER	Parity of receive data differs from even/odd parity setting in SMR	Receive data loaded from RSR into RDR

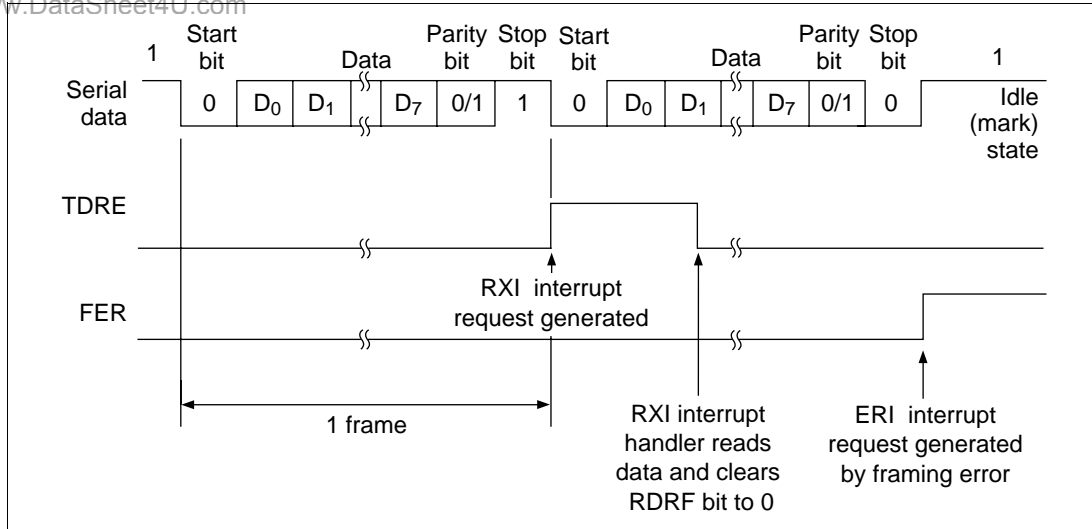

**Figure 13.8 Example of SCI Receive Operation
(8-Bit Data with Parity and One Stop Bit)**

13.3.3 Multiprocessor Communication

The multiprocessor communication function enables several processors to share a single serial communication line. The processors communicate in asynchronous mode using a format with an additional multiprocessor bit (multiprocessor format).

In multiprocessor communication, each receiving processor is addressed by a unique ID. A serial communication cycle consists of an ID-sending cycle that identifies the receiving processor, and a data-sending cycle. The multiprocessor bit distinguishes ID-sending cycles from data-sending cycles. The transmitting processor starts by sending the ID of the receiving processor with which it wants to communicate as data with the multiprocessor bit set to 1. Next, the transmitting processor sends transmit data with the multiprocessor bit cleared to 0.

Receiving processors skip incoming data until they receive data with the multiprocessor bit set to 1. When they receive data with the multiprocessor bit set to 1, receiving processors compare the data with their IDs. The receiving processor with a matching ID continues to receive further incoming data. Processors with IDs not matching the received data skip further incoming data until they again receive data with the multiprocessor bit set to 1. Multiple processors can send and receive data in this way.

Figure 13.9 shows an example of communication among processors using the multiprocessor format.

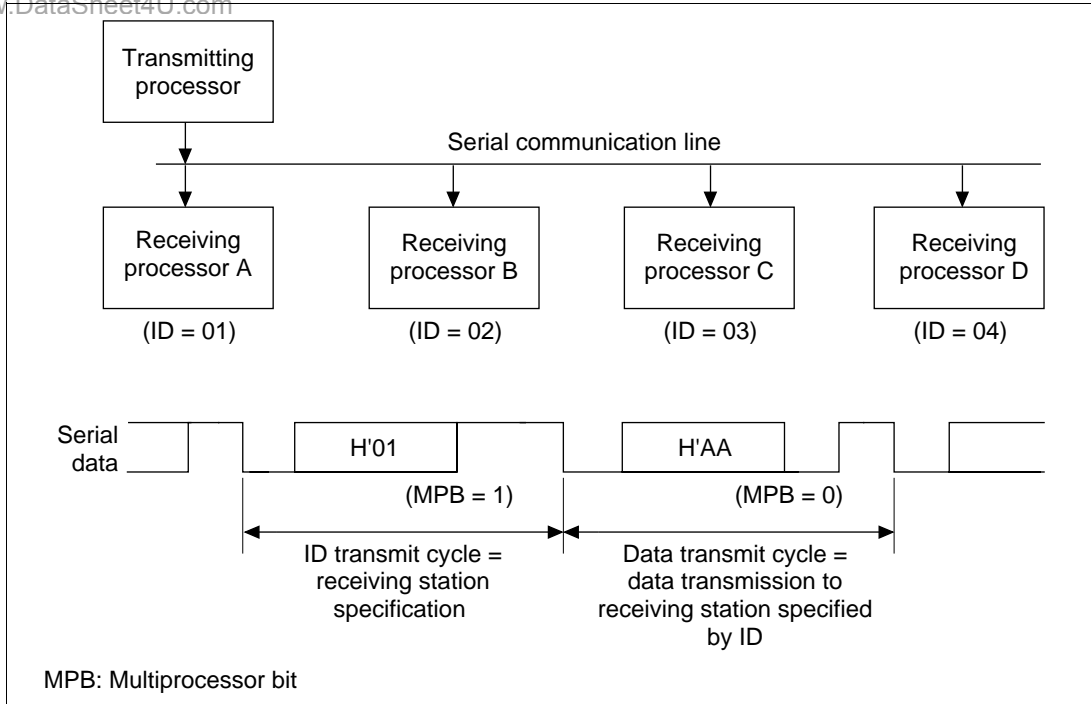

Figure 13.9 Example of Communication among Processors Using Multiprocessor Format (Sending Data H'AA to Receiving Processor A)

Communication Formats: Four formats are available. Parity-bit settings are ignored when the multiprocessor format is selected. For details see table 13.8.

Clock: See the description in the asynchronous mode section.

Transmitting Multiprocessor Serial Data: Figure 13.10 shows a sample flowchart for transmitting multiprocessor serial data. The procedure for transmitting multiprocessor serial data is as follows:

1. SCI status check and transmit data write: read the serial status register (SSR), check that the TDRE bit is 1, then write transmit data in the transmit data register (TDR). Also set the MPBT (multiprocessor bit transfer) bit to 0 or 1 in SSR. Finally, clear TDRE to 0.
2. To continue transmitting serial data, read the TDRE bit to check whether it is safe to write (if it reads 1); if so, write data in TDR, then clear TDRE to 0. When the DMAC is started by a transmit-data-empty interrupt request (TXI) to write data in TDR, the TDRE bit is checked and cleared automatically.

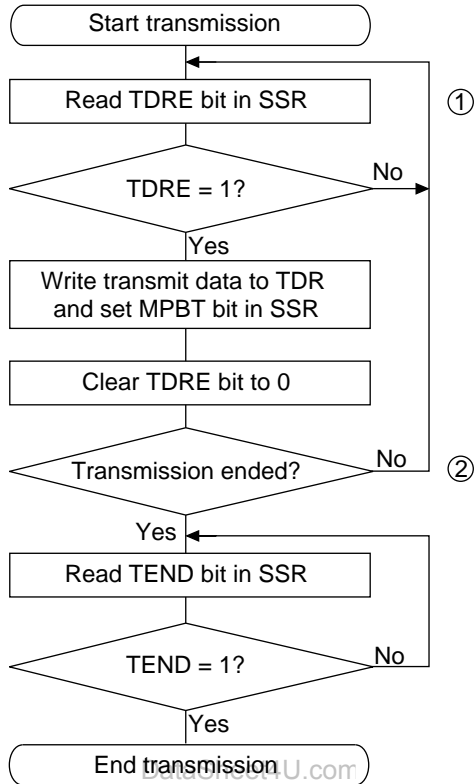

Note: Circled numbers refer to the preceding description of the procedure in the text.

Figure 13.10 Sample Flowchart for Transmitting Multiprocessor Serial Data

In transmitting serial data, the SCI operates as follows:

1. The SCI monitors the TDRE bit in SSR. When TDRE is cleared to 0 the SCI recognizes that the transmit data register (TDR) contains new data, and loads this data from TDR into the transmit shift register (TSR).
2. After loading the data from TDR into TSR, the SCI sets the TDRE bit to 1 and starts transmitting. If the transmit-data-empty interrupt enable bit (TIE) in SCR is set to 1, the SCI requests a transmit-data-empty interrupt (TXI) at this time.

Serial transmit data is transmitted in the following order from the TxD pin:

- a. Start bit: one 0 bit is output.
- b. Transmit data: seven or eight bits are output, LSB first.
- c. Multiprocessor bit: one multiprocessor bit (MPBT value) is output.
- d. Stop bit: one or two 1-bits (stop bits) are output.
- e. Mark state: output of 1-bits continues until the start bit of the next transmit data.

- The SCI checks the TDRE bit when it outputs the stop bit. If TDRE is 0, the SCI loads data from TDR into TSR, outputs the stop bit, then begins serial transmission of the next frame. If TDRE is 1, the SCI sets the TEND bit in SSR to 1, outputs the stop bit, then continues output of 1-bits in the mark state. If the transmit-end interrupt enable bit (TEIE) in SCR is set to 1, a transmit-end interrupt (TEI) is requested at this time.

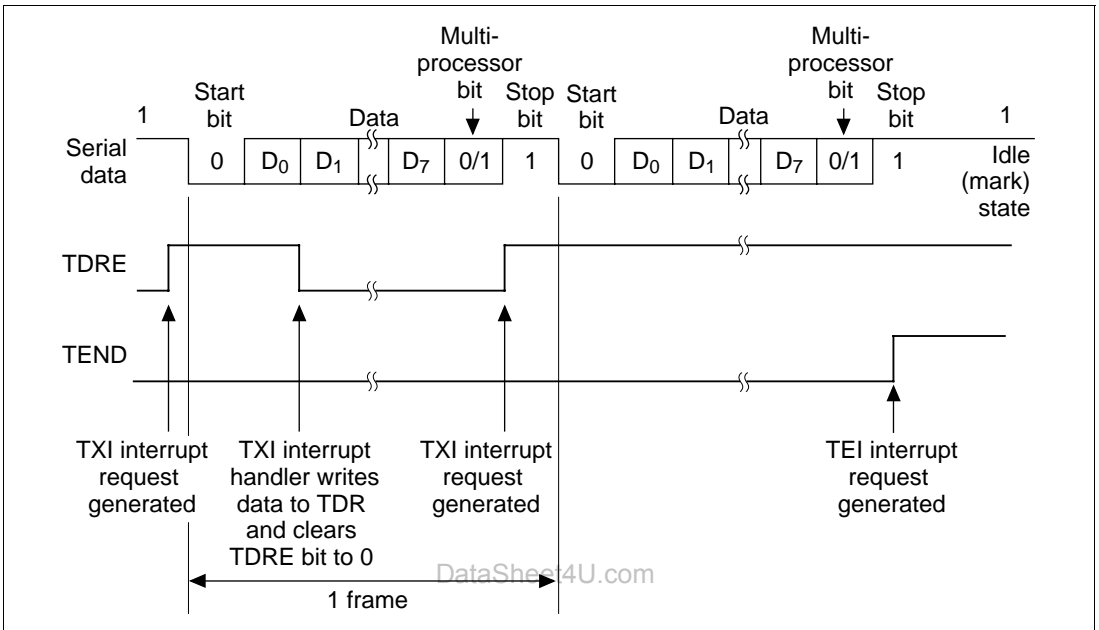
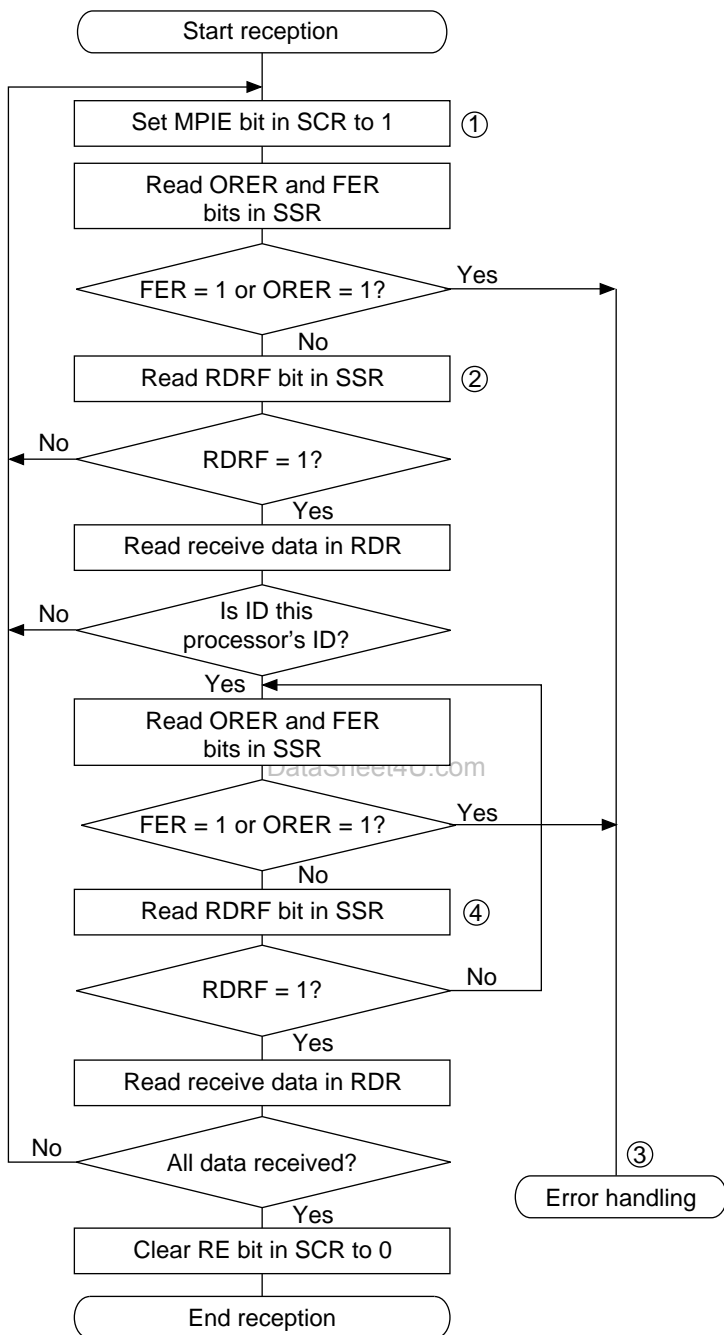

Figure 13.11 Example of SCI Multiprocessor Transmit Operation (8-Bit Data with Multiprocessor Bit and One Stop Bit)

Receiving Multiprocessor Serial Data: Figure 13.12 shows a sample flowchart for receiving multiprocessor serial data. The procedure for receiving multiprocessor serial data is as follows.

- ID receive cycle: set the MPIE bit in the serial control register (SCR) to 1.
- SCI status check, ID reception and comparison: read the serial status register (SSR), check that RDRF is set to 1, then read data from the receive data register (RDR) and compare with the processor's own ID. If the ID does not match the receive data, set MPIE to 1 again and clear RDRF to 0. If the ID matches the receive data, clear RDRF to 0.
- Receive error handling: if a receive error occurs (figure 13.12 (cont)), read the ORER and FER bits in SSR to identify the error. After executing the necessary error handling, clear both ORER and FER to 0. Receiving cannot resume if ORER or FER remains set to 1. When a framing error occurs, the RxD pin can be read to detect the break state.
- SCI status check and data receiving: read SSR, check that RDRF is set to 1, then read data from the receive data register (RDR).



Note: Circled numbers refer to the preceding description of the procedure in the text.

Figure 13.12 Sample Flowchart for Receiving Multiprocessor Serial Data

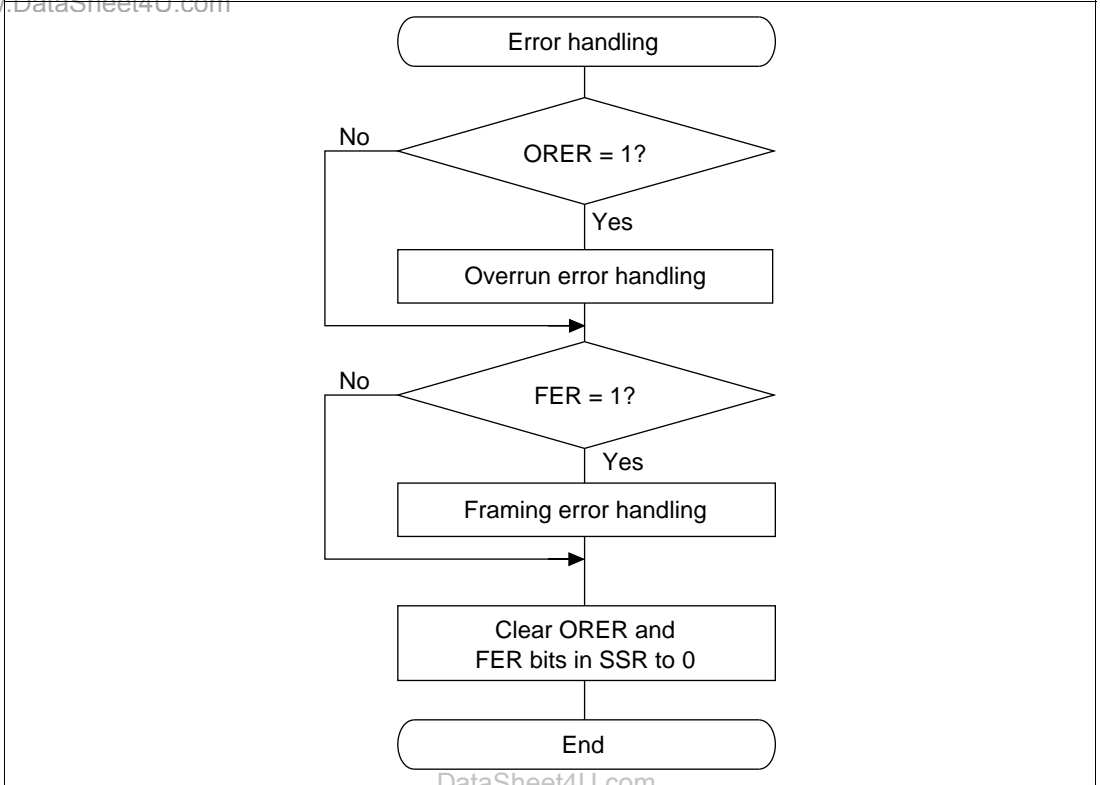

DataSheet4U.com

Figure 13.12 Sample Flowchart for Receiving Multiprocessor Serial Data (cont)

Figure 13.13 shows an example of SCI receive operation using a multiprocessor format.

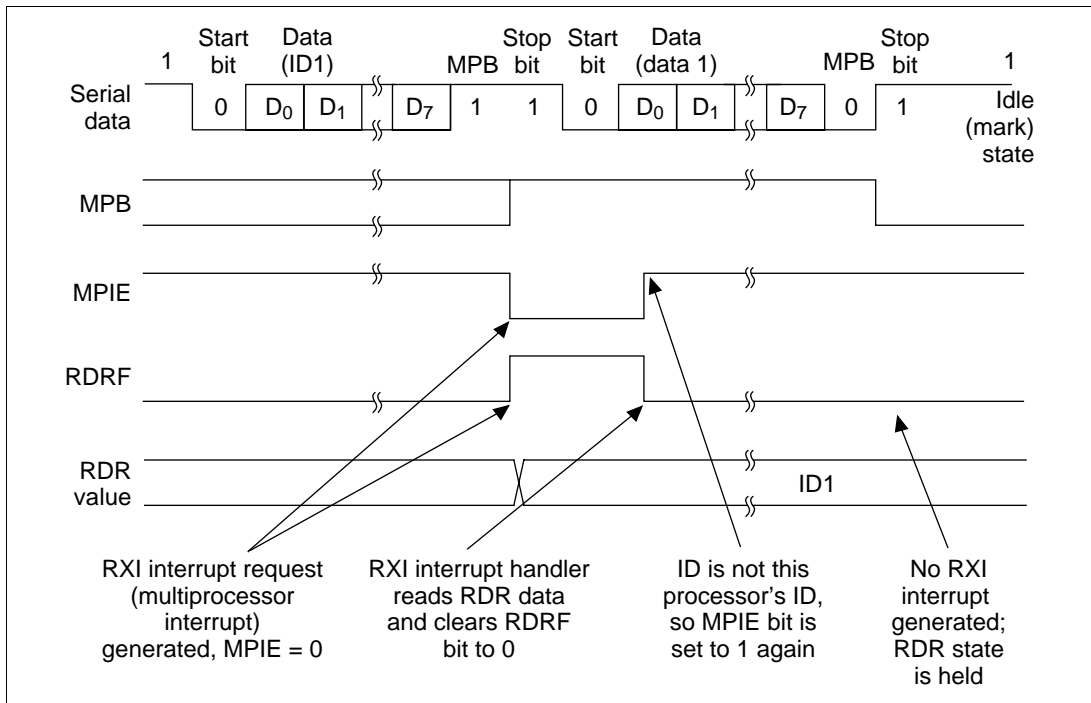

Figure 13.13 Example of SCI Receive Operation

(Own ID Does Not Match Data, 8-Bit Data with Multiprocessor Bit and One Stop Bit)

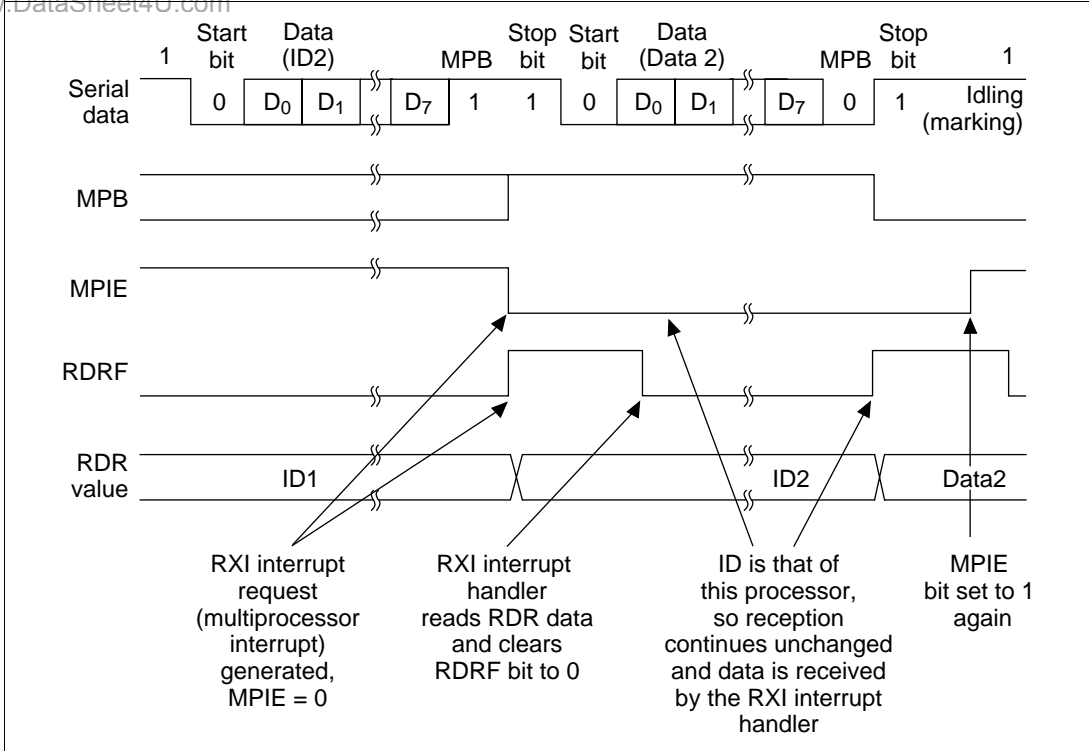

Figure 13.13 Example of SCI Receive Operation (Own ID Matches Data, 8-Bit Data with Multiprocessor Bit and One Stop Bit) (cont)

13.3.4 Clocked Synchronous Operation

In clocked synchronous mode, the SCI transmits and receives data in synchronization with clock pulses. This mode is suitable for high-speed serial communication.

The SCI transmitter and receiver are independent, so full duplex communication is possible while sharing the same clock. The transmitter and receiver are also double buffered, so continuous transmitting or receiving is possible by reading or writing data while transmitting or receiving is in progress.

Figure 13.14 shows the general format in clocked synchronous serial communication.

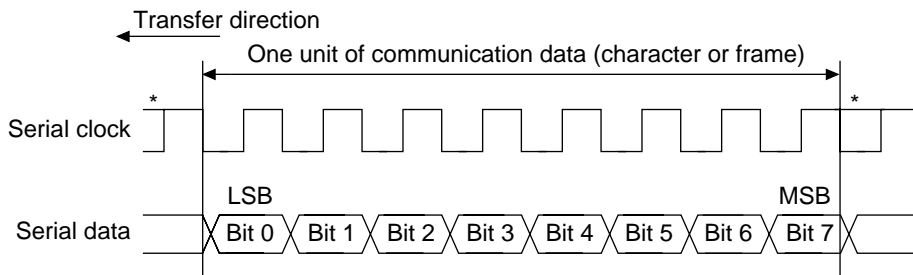

Note: High except in continuous transmitting or receiving.

Figure 13.14 Data Format in Clocked Synchronous Communication

In clocked synchronous serial communication, each data bit is output on the communication line from one falling edge of the serial clock to the next. Data is guaranteed valid at the rising edge of the serial clock. In each character, the serial data bits are transmitted in order from LSB (first) to MSB (last). After output of the MSB, the communication line remains in the state of the MSB. In clocked synchronous mode, the SCI transmits or receives data by synchronizing with the falling edge of the serial clock.

Communication Format: The data length is fixed at eight bits. No parity bit or multiprocessor bit can be added.

DataSheet4U.com

Clock: An internal clock generated by the built-in baud rate generator or an external clock input from the SCK pin can be selected as the SCI transmit/receive clock. The clock source is selected by the C/A bit in the serial mode register (SMR) and bits CKE1 and CKE0 in the serial control register (SCR). See table 13.9.

When the SCI operates on an internal clock, it outputs the clock signal at the SCK pin. Eight clock pulses are output per transmitted or received character. When the SCI is not transmitting or receiving, the clock signal remains in the high state.

Figure 13.15 shows an example of SCI transmit operation. In transmitting serial data, the SCI operates as follows.

1. The SCI monitors the TDRE bit in SSR. When TDRE is cleared to 0 the SCI recognizes that the transmit data register (TDR) contains new data and loads this data from TDR into the transmit shift register (TSR).
2. After loading the data from TDR into TSR, the SCI sets the TDRE bit to 1 and starts transmitting. If the transmit-data-empty interrupt enable bit (TIE) in SCR is set to 1, the SCI requests a transmit-data-empty interrupt (TXI) at this time.

If clock output mode is selected, the SCI outputs eight synchronous clock pulses. If an external clock source is selected, the SCI outputs data in synchronization with the input clock. Data is output from the TxD pin in order from LSB (bit 0) to MSB (bit 7).

- The SCI checks the TDRE bit when it outputs the MSB (bit 7). If TDRE is 0, the SCI loads data from TDR into TSR, transmits the MSB, then begins serial transmission of the next frame. If TDRE is 1, the SCI sets the TEND bit in SSR to 1, transmits the MSB, then holds the transmit data pin (TxD) in the MSB state. If the transmit-end interrupt enable bit (TEIE) in SCR is set to 1, a transmit-end interrupt (TEI) is requested at this time.
- After the end of serial transmission, the SCK pin is held in the high state.

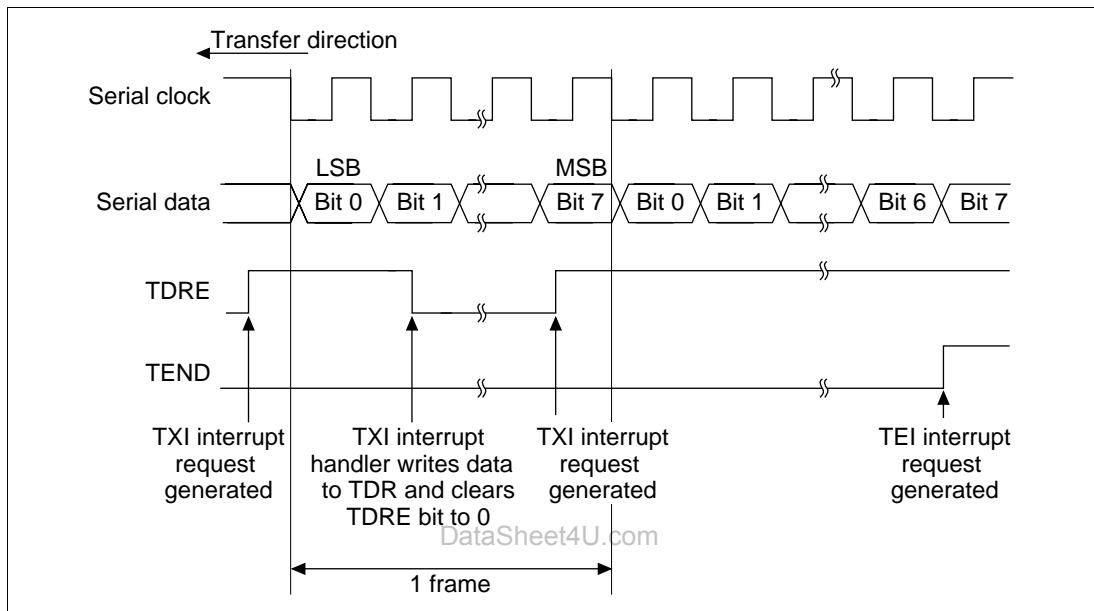

Figure 13.15 Example of SCI Transmit Operation

Transmitting and Receiving Data

SCI Initialization (Clocked Synchronous Mode): Before transmitting or receiving, software must clear the TE and RE bits to 0 in the serial control register (SCR), then initialize the SCI as follows.

When changing the mode or communication format, always clear the TE and RE bits to 0 before following the procedure given below. Clearing TE to 0 sets TDRE to 1 and initializes the transmit shift register (TSR). Clearing RE to 0, however, does not initialize the RDRF, PER, FER, and ORER flags and receive data register (RDR), which retain their previous contents.

Figure 13.16 shows a sample flowchart for initializing the SCI. The procedure for initializing the SCI is as follows.

- Select the communication format in the serial mode register (SMR).
- Write the value corresponding to the bit rate in the bit rate register (BRR) unless an external clock is used.

- www.DataSheet4U.com
- Select the clock source in the serial control register (SCR). Leave RIE, TIE, TEIE, MPIE, TE and RE cleared to 0.
 - Wait for at least the interval required to transmit or receive one bit, then set TE or RE in the serial control register (SCR) to 1. Also set RIE, TIE, TEIE and MPIE.

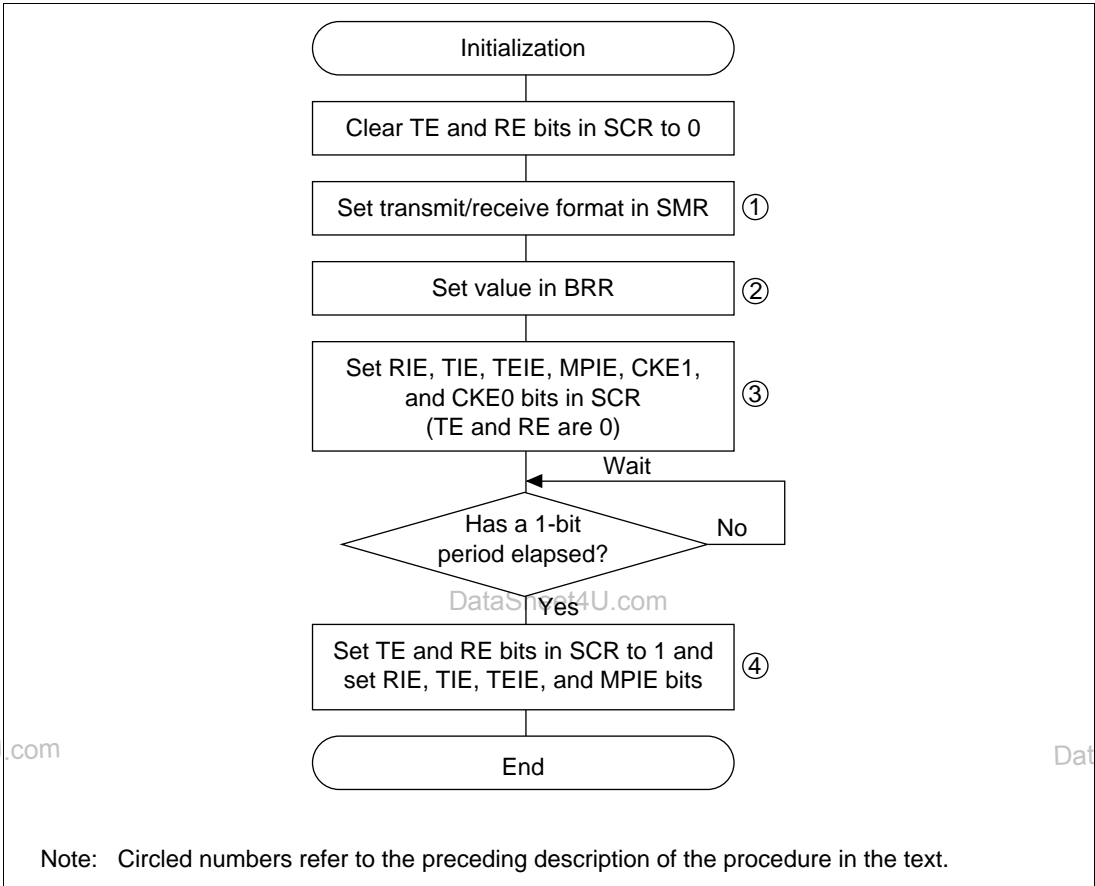
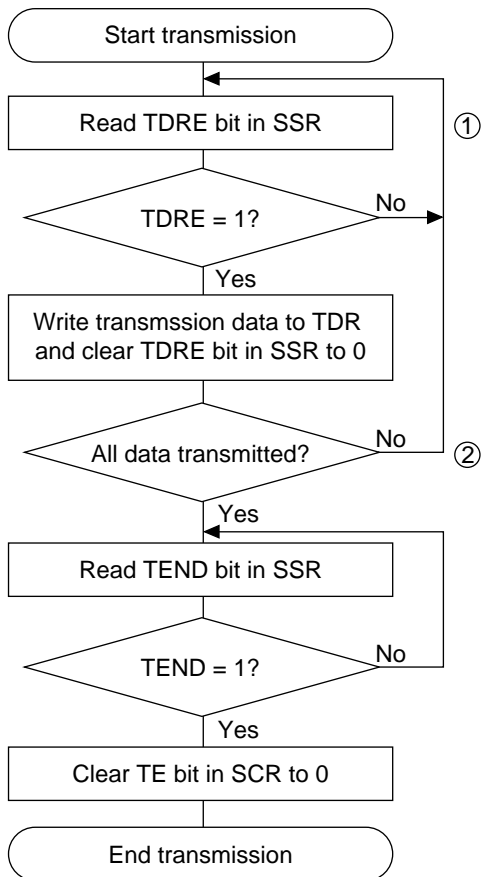

Figure 13.16 Sample Flowchart for SCI Initialization

Transmitting Serial Data (Clocked Synchronous Mode): Figure 13.17 shows a sample flowchart for transmitting serial data. The procedure for transmitting serial data is as follows.

- SCI status check and transmit data write: read the serial status register (SSR), check that the TDRE bit is 1, then write transmit data in the transmit data register (TDR) and clear TDRE to 0.
- To continue transmitting serial data, read the TDRE bit to check whether it is safe to write (if it reads 1); if so, write data in TDR, then clear TDRE to 0. When the DMAC is started by a transmit-data-empty interrupt request (TXI) to write data in TDR, the TDRE bit is checked and cleared automatically.



Note: Circled numbers refer to the preceding description of the procedure in the text.

Figure 13.17 Sample Flowchart for Serial Transmitting

Receiving Serial Data (Clocked Synchronous Mode): Figure 13.18 shows a sample flowchart for receiving serial data. When switching from asynchronous mode to clocked synchronous mode, make sure that ORER, PER, and FER are cleared to 0. If PER or FER is set to 1, the RDRF bit will not be set and both transmitting and receiving will be disabled. Figure 13.19 shows an example of the SCI receive operation.

The procedure for receiving serial data is as follows:

1. Receive error handling: if a receive error occurs, read the ORER bit in SSR to identify the error. After executing the necessary error handling, clear ORER to 0. Transmitting/receiving cannot resume if ORER remains set to 1.

2. SCI status check and receive data read: read the serial status register (SSR), check that RDRF is set to 1, then read receive data from the receive data register (RDR) and clear RDRF to 0. The RXI interrupt can also be used to determine if the RDRF bit has changed from 0 to 1.
3. To continue receiving serial data: read RDR, and clear RDRF to 0 before the MSB (bit 7) of the current frame is received. If the DMAC is started by a receive-data-full interrupt (RXI) to read RDR, the RDRF bit is cleared automatically so this step is unnecessary.

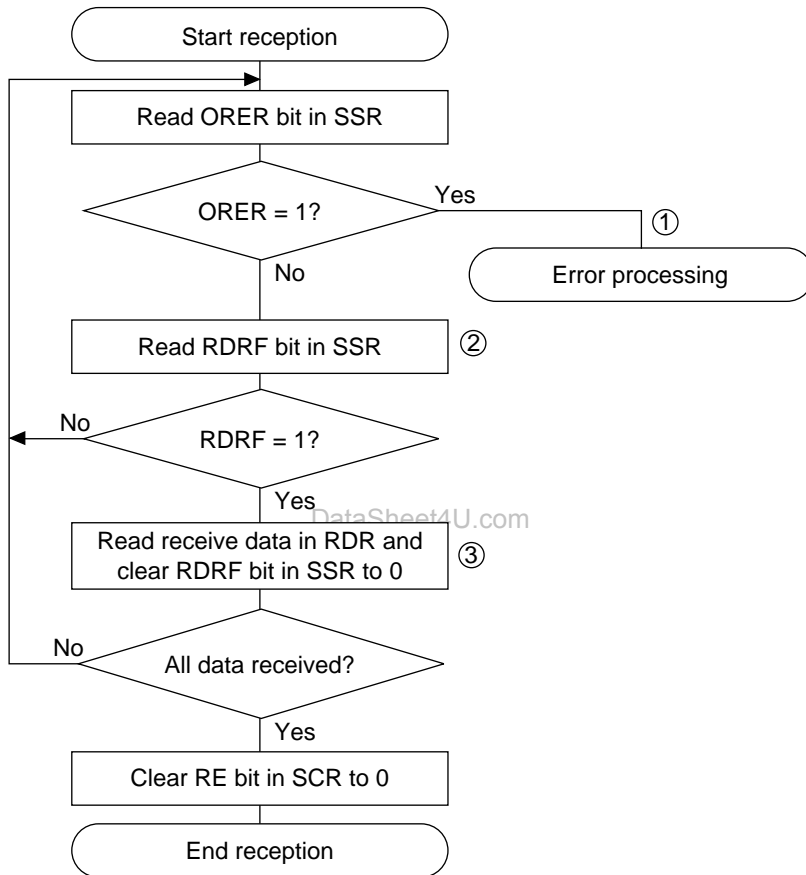

Note: Circled numbers refer to the preceding description of the procedure in the text.

Figure 13.18 Sample Flowchart for Serial Receiving

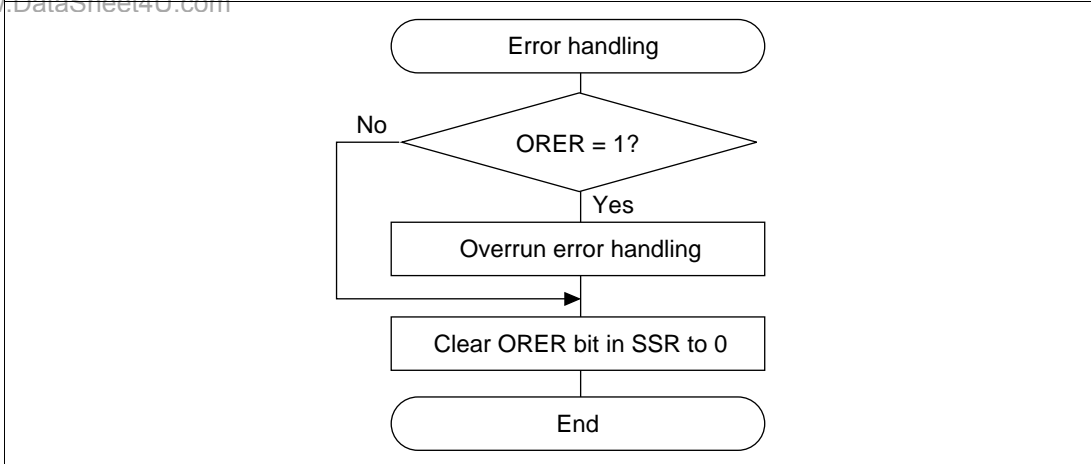

Figure 13.18 Sample Flowchart for Serial Receiving (cont)

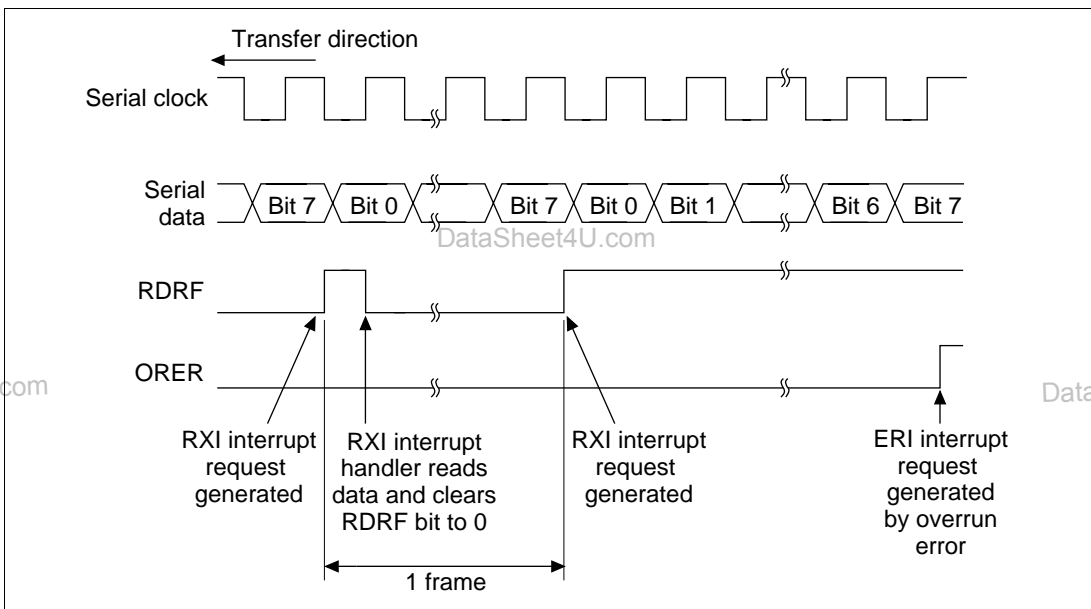

Figure 13.19 Example of SCI Receive Operation

In receiving, the SCI operates as follows:

1. The SCI synchronizes with serial clock input or output and initializes internally.
2. Receive data is shifted into RSR in order from LSB to MSB. After receiving the data, the SCI checks that RDRF is 0 so that receive data can be loaded from RSR into RDR. If this check passes, the SCI sets RDRF to 1 and stores the received data in RDR. If the check does not pass (receive error), the SCI operates as indicated in table 13.8. The RDRF bit is not set to 1. Be sure to clear the error flag.
3. After setting RDRF to 1, if the receive-data-full interrupt enable bit (RIE) is set to 1 in SCR, the SCI requests a receive-data-full interrupt (RXI). If the ORER bit is set to 1 and the receive-data-full interrupt enable bit (RIE) in SCR is also set to 1, the SCI requests a receive-error interrupt (ERI).

Transmitting and Receiving Serial Data Simultaneously (Clocked Synchronous Mode):

Figure 13.20 shows a sample flowchart for transmitting and receiving serial data simultaneously. The procedure for transmitting and receiving serial data simultaneously is as follows:

1. SCI status check and transmit data write: read the serial status register (SSR), check that the TDRE bit is 1, then write transmit data in the transmit data register (TDR) and clear TDRE to 0. The TXI interrupt can also be used to determine if the TDRE bit has changed from 0 to 1.
2. Receive error handling: if a receive error occurs, read the ORER bit in SSR to identify the error. After executing the necessary error handling, clear ORER to 0. Transmitting/receiving cannot resume if ORER remains set to 1.
3. SCI status check and receive data read: read the serial status register (SSR), check that RDRF is set to 1, then read receive data from the receive data register (RDR) and clear RDRF to 0. The RXI interrupt can also be used to determine if the RDRF bit has changed from 0 to 1.
4. To continue transmitting and receiving serial data: read the RDRF bit and RDR, and clear RDRF to 0 before the MSB (bit 7) of the current frame is received. Also read the TDRE bit to check whether it is safe to write (if it reads 1); if so, write data in TDR, then clear TDRE to 0 before the MSB (bit 7) of the current frame is transmitted. When the DMAC is started by a transmit-data-empty interrupt request (TXI) to write data in TDR, the TDRE bit is checked and cleared automatically. When the DMAC is started by a receive-data-full interrupt (RXI) to read RDR, the RDRF bit is cleared automatically.

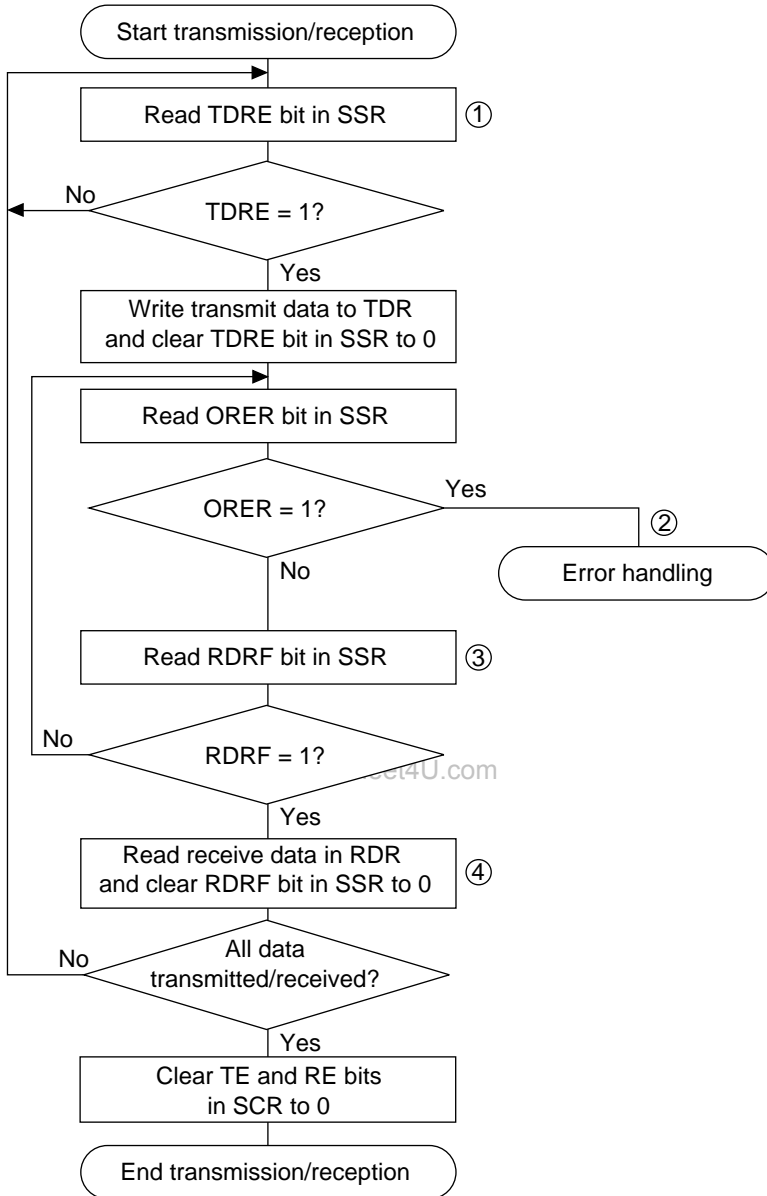

Note: When switching from transmitting or receiving to simultaneous transmitting and receiving, clear both TE and RE to 0, then set both TE and RE to 1.
Circled numbers refer to the preceding description of the procedure in the text.

Figure 13.20 Sample Flowchart for Serial Transmitting

13.4 SCI Interrupt Sources and the DMAC

The SCI has four interrupt sources in each channel: transmit-end (TEI), receive-error (ERI), receive-data-full (RXI), and transmit-data-empty (TXI). Table 13.13 lists the interrupt sources and indicates their priority. These interrupts can be enabled and disabled by the TIE, RIE, and TEIE bits in the serial control register (SCR). Each interrupt request is sent separately to the interrupt controller.

TXI is requested when the TDRE bit in SSR is set to 1. TXI can start the direct memory access controller (DMAC) to transfer data. TDRE is automatically cleared to 0 when the DMAC writes data in the transmit data register (TDR).

RXI is requested when the RDRF bit in SSR is set to 1. RXI can start the DMAC to transfer data. RDRF is automatically cleared to 0 when the DMAC reads the receive data register (RDR).

ERI is requested when the ORER, PER, or FER bit in SSR is set to 1. ERI cannot start the DMAC.

TEI is requested when the TEND bit in SSR is set to 1. TEI cannot start the DMAC. Where the TXI interrupt indicates that transmit data writing is enabled, the TEI interrupt indicates that the transmit operation is complete.

Table 13.13 SCI Interrupt Sources

Interrupt Source	Description	DMAC Availability	Priority
ERI	Receive error (ORER, PER, or FER)	No	High
RXI	Receive data register full (RDRF)	Yes	↑
TXI	Transmit data register empty (TDRE)	Yes	↓
TEI	Transmit end (TEND)	No	Low

See section 4, Exception Handling, for information on the priority order and relationship to non-SCI interrupts.

13.5 Usage Notes

Note the following points when using the SCI.

TDR Write and TDRE Flag: The TDRE bit in the serial status register (SSR) is a status flag indicating loading of transmit data from TDR into TSR. The SCI sets TDRE to 1 when it transfers data from TDR to TSR. Data can be written to TDR regardless of the TDRE bit status. If new data is written in TDR when TDRE is 0, however, the old data stored in TDR will be lost because the data has not yet been transferred to TSR. Before writing transmit data to TDR, be sure to check that TDRE is set to 1.

Simultaneous Multiple Receive Errors: Table 13.14 indicates the state of the SSR status flags when multiple receive errors occur simultaneously. When an overrun error occurs, the RSR contents cannot be transferred to RDR, so receive data is lost.

Table 13.14 SSR Status Flags and Transfer of Receive Data

Receive Error Status	SSR Status Flags				Receive Data Transfer
	RDRF	ORER	FER	PER	RSR → RDR
Overrun error	1	1	0	0	X
Framing error	0	0	1	0	O
Parity error	0	0	0	1	O
Overrun error + framing error	1	1	1	0	X
Overrun error + parity error	1	1	0	1	X
Framing error + parity error	0	0	1	1	O
Overrun error + framing error + parity error	1	1	1	1	X

O: Receive data is transferred from RSR to RDR.

X: Receive data is not transferred from RSR to RDR.

Break Detection and Processing: In the break state, the input from the RxD pin consists of all 0s, so FER is set and the parity error flag (PER) may also be set. In the break state, the SCI receiver continues to operate, so if the FER bit is cleared to 0, it will be set to 1 again.

Receive Error Flags and Transmitter Operation (Clocked Synchronous Mode Only): When a receive error flag (ORER, PER, or FER) is set to 1, the SCI will not start transmitting even if TDRE is set to 1. Be sure to clear the receive error flags to 0 before starting to transmit. Note that clearing RE to 0 does not clear the receive error flags.

Receive Data Sampling Timing and Receive Margin in Asynchronous Mode: In asynchronous mode, the SCI operates on a base clock of 16 times the bit rate frequency. In receiving, the SCI synchronizes internally with the falling edge of the start bit, which it samples on the base clock. Receive data is latched on the rising edge of the eighth base clock pulse. See figure 13.21.

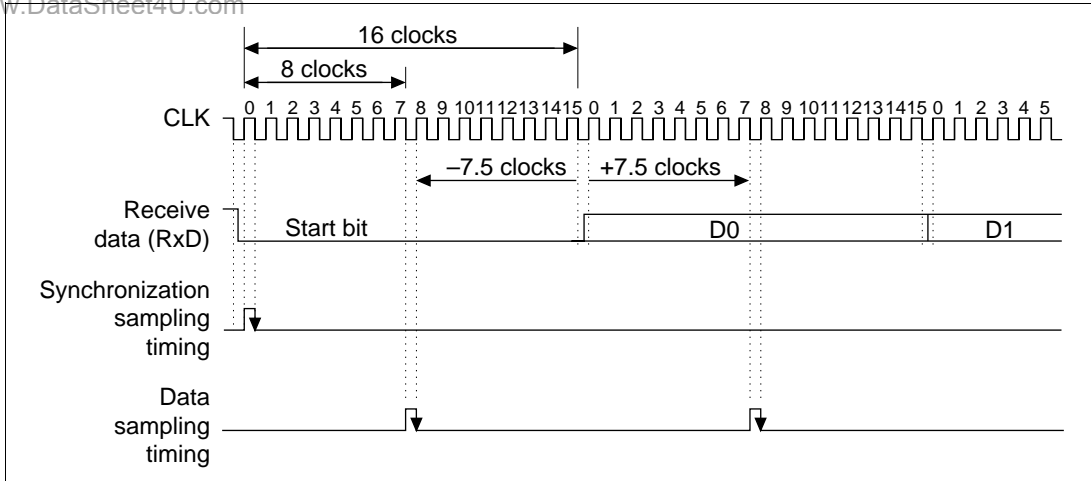

Figure 13.21 Receive Data Sampling Timing in Asynchronous Mode

The receive margin in asynchronous mode can therefore be expressed as in equation 1.

Equation 1:

$$M = \left| \left(0.5 - \frac{1}{2N} - 1 \right) - (L - 0.5) F - \frac{|D - 0.5|}{N} (1 + F) \right| \times 100\%$$

M : Receive margin (%)

DataSheet4U.com

N : Ratio of clock frequency to bit rate (N = 16)

D : Clock duty cycle (D = 0–1.0)

L : Frame length (L = 9–12)

F : Absolute deviation of clock frequency

et4U.com

DataShee

From equation (1), if F = 0 and D = 0.5 the receive margin is 46.875%, as given by equation 2.

Equation 2:

$$D = 0.5, F = 0$$

$$M = (0.5 - 1/(2 \times 16)) \times 100\%$$

$$= 46.875\%$$

This is a theoretical value. A reasonable margin to allow in system designs is 20–30%.

Constraints on DMAC Use:

- When using an external clock source for the serial clock, update TDR with the DMAC, and then after twenty system clock cycles or more elapse, input a transmit clock. If a transmit clock is input in the first four states after TDR is written, an error may occur (figure 13.22).
- Before reading the receive data register (RDR) with the DMAC, select the receive-data-full interrupt of the SCI as an activation source using the resource select bit (RS) in the channel control register (CHCR).

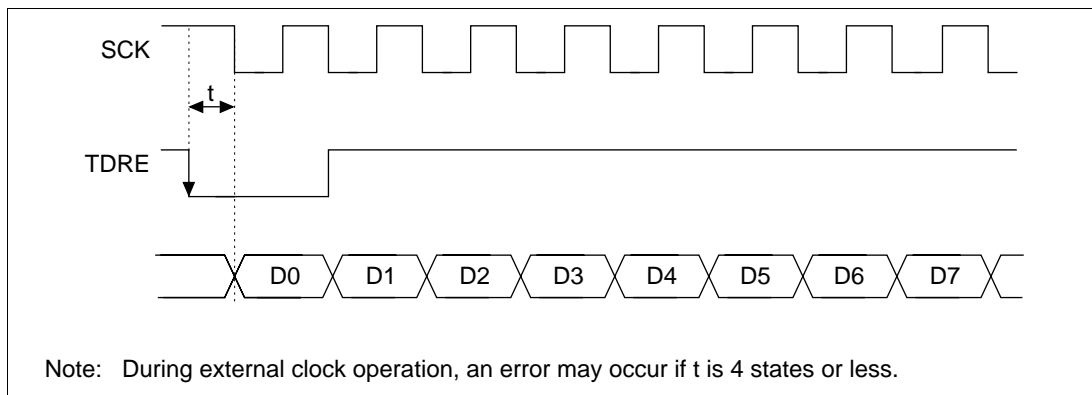

Figure 13.22 Example of Clocked Synchronous Transmission with DMAC

Cautions for Clocked Synchronous External Clock Mode:

- Set $TE = RE = 1$ only when external clock SCK is 1.
- Do not set $TE = RE = 1$ until at least four clock cycles after external clock SCK has changed from 0 to 1.
- When receiving, RDRF is set to 1 when RE is cleared to 0 2.5–3.5 clocks after the rising edge of the RxD D7 bit SCK input, but it cannot be copied to RDR.

Caution for Clocked Synchronous Internal Clock Mode: When receiving, RDRF is set to 1 when RE is cleared to 0 1.5 clocks after the rising edge of the RxD D7 bit SCK output, but it cannot be copied to RDR.

DataSheet4U.com

et4U.com

DataShee

DataSheet4U.com

www.DataSheet4U.com

Section 14 Power-Down Modes

14.1 Overview

The SH7604 has a module standby function (which selectively halts operation of some on-chip peripheral modules), a sleep mode (which halts CPU function), and a standby mode (which halts all functions).

14.1.1 Power-Down Modes

In addition to the sleep mode and standby mode, the SH7604 also has a third power-down mode, the module standby function, which halts the DMAC, multiplication unit, division unit, free-running timer, and SCI on-chip peripheral modules.

Table 14.1 shows the transition conditions for entering the modes from the program execution state, as well as the CPU and peripheral module states in each mode and the procedures for canceling each mode.

DataSheet4U.com

et4U.com

DataShee

DataSheet4U.com

www.DataSheet4U.com

DataSheet4U.com

Table 14.1 Power-Down Modes

Mode	Transition Condition	State					Canceling Procedure
		Clock	CPU, MULT, Cache	UBC, BSC	FRT, SCI, DMAC, DIV, INTC, WDT, Pins		
Sleep mode	SLEEP instruction executed with SBY bit set to 0 in SBYCR	Runs	Halted	Runs	Runs	Runs	<ol style="list-style-type: none"> 1. Interrupt 2. DMA address error 3. Power-on reset 4. Manual reset
Standby mode	SLEEP instruction executed with SBY bit set to 1 in SBYCR	Halted	Halted	Held	Halted	Held or high impedance	<ol style="list-style-type: none"> 1. NMI interrupt 2. Power-on reset 3. Manual reset
Module standby function	MSTP bit for relevant module is set to 1	Runs	Run (MULT is held)	Runs	When MSTP bit is 1, the supply of the clock to the relevant module is halted.	FRT and SCI pins are initialized, and others operate.	Clear MSTP bit to 0

14.1.2 Register

Table 14.2 shows the register configuration.

Table 14.2 Register Configuration

Name	Abbreviation	R/W	Initial Value	Address
Standby control register	SBYCR	R/W	H'60	H'FFFFFFE91

14.2 Description of Register

14.2.1 Standby Control Register (SBYCR)

The standby control register (SBYCR) is an 8-bit read/write register that sets the power-down mode. SBYCR is initialized to H'00 by a reset.

Bit:	7	6	5	4	3	2	1	0
Bit name:	SBY	HIZ	—	MSTP4	MSTP3	MSTP2	MSTP1	MSTP0
Initial value:	0	0	0	0	0	0	0	0
R/W:	R/W	R/W	—	R/W	R/W	R/W	R/W	R/W

- Bit 7—Standby (SBY): Specifies transition to standby mode. The SBY bit cannot be set to 1 while the watchdog timer is running (when the TME bit in the WDT's WTCSR register is 1). To enter the standby mode, halt the WDT (set the TME bit in WTCSR to 0) and set the SBY bit.

Bit 7: SBY	Description
0	Executing a SLEEP instruction puts the chip into sleep mode (Initial value)
1	Executing a SLEEP instruction puts the chip into standby mode

DataSheet4U.com

- Bit 6—Port High Impedance (HIZ): Selects whether output pins are set to high impedance or retain the output state in standby mode. When HIZ = 0 (initial state), the specified pin retains its output state. When HIZ = 1, the pin goes to the high-impedance state. See Appendix A.1, Pin States during Resets, Power-Down States and Bus Release State, for which pins are controlled.

Bit 6: HIZ	Description
0	Pin state retained in standby mode (Initial value)
1	Pin goes to high impedance in standby mode

- Bit 5—Reserved: This bit always reads 0. The write value should always be 0.
- Bit 4: Module stop 4 (MSTP4): Specifies halting the clock supply to the DMAC. When MSTP4 bit is set to 1, the supply of the clock to the DMAC is halted. When the clock halts, the DMAC retains its pre-halt state. When MSTP4 is cleared to 0 and the DMAC begins running again, it starts operating from its pre-halt state. Set this bit while the DMAC is halted; this bit cannot be set while the DMAC is operating (transferring data).

Bit 4: MSTP4	Description	
0	DMAC running	(Initial value)
1	Clock supply to DMAC halted	

- Bit 3—Module Stop 3 (MSTP3): Specifies halting the clock supply to the multiplication unit (MULT). When the MSTP3 bit is set to 1, the supply of the clock to MULT is halted. When the clock halts, MULT retains its pre-halt state. This bit should be set when the MULT is halted.

Bit 3: MSTP3	Description	
0	MULT running	(Initial value)
1	Clock supply to MULT halted	

- Bit 2—Module Stop 2 (MSTP2): Specifies halting the clock supply to the division unit (DIVU). When the MSTP2 bit is set to 1, the supply of the clock to DIVU is halted. When the clock halts, the DIVU registers retain their pre-halt state. This bit should be set when the DIVU is halted.

Bit 2: MSTP2	Description	
0	DIVU running	(Initial value)
1	Clock supply to DIVU halted	

- Bit 1—Module Stop 1 (MSTP1): Specifies halting the clock supply to the 16-bit free-running timer (FRT). When the MSTP1 bit is set to 1, the supply of the clock to the FRT is halted. When the clock halts, all FRT registers are initialized except the FRT interrupt vector register in INTC, which holds its previous value. When MSTP1 is cleared to 0 and the FRT begins running again, it starts operating from its initial state.

Bit 1: MSTP1	Description	
0	FRT running	(Initial value)
1	Clock supply to FRT halted	

- Bit 0—Module Stop 0 (MSTP0): Specifies halting the clock supply to the serial communication interface (SCI). When the MSTP0 bit is set to 1, the supply of the clock to the SCI is halted. When the clock halts, all SCI registers are initialized except the SCI interrupt vector register in INTC, which holds its previous value. When MSTP0 is cleared to 0 and the SCI begins running again, it starts operating from its initial state.

Bit 0: MSTP0	Description	
0	SCI running	(Initial value)
1	Clock supply to SCI halted	

14.3 Sleep Mode

14.3.1 Transition to Sleep Mode

Executing the SLEEP instruction when the SBY bit in SBYCR is 0 causes a transition from the program execution state to sleep mode. Although the CPU halts immediately after executing the SLEEP instruction, the contents of its internal registers remain unchanged. The on-chip peripheral modules continue to run in sleep mode.

14.3.2 Canceling Sleep Mode

Sleep mode is canceled by an interrupt, DMA address error, power-on reset, or manual reset.

Cancellation by an Interrupt: When an interrupt occurs, sleep mode is canceled and interrupt exception handling is executed. Sleep mode is not canceled if the interrupt cannot be accepted because its priority level is equal to or less than the mask level set in the CPU's status register (SR) or if an interrupt by an on-chip peripheral module is disabled at the peripheral module.

Cancellation by a DMA Address Error: If a DMA address error occurs, sleep mode is canceled and DMA address error exception handling is executed.

Cancellation by a Power-On Reset: A power-on reset cancels sleep mode.

Cancellation by a Manual Reset: A manual reset cancels sleep mode.

14.4 Standby Mode

14.4.1 Transition to Standby Mode

To enter standby mode, set the SBY bit to 1 in SBYCR, then execute the SLEEP instruction. The chip switches from the program execution state to standby mode. The NMI interrupt cannot be accepted when the SLEEP instruction is executed, or for the following five cycles. In standby mode, power consumption is greatly reduced by halting not only the CPU, but the clock and on-chip peripheral modules as well. CPU register contents are held, and some on-chip peripheral modules are initialized.

Table 14.3 Register States in Standby Mode

Module	Registers Initialized	Registers that Retain Data	Registers with Undefined Contents
Interrupt controller (INTC)	—	All registers	—
User break controller (UBC)	—	All registers	—
Bus state controller (BSC)	—	All registers	—
DMAC	DMA channel control register 0 DMA channel control register 1 DMA operation register	All registers except DMA channel control register 0, DMA channel control register 1, and DMA operation register	—
DIVU	—	—	All registers
Watchdog timer (WDT)	Bits 7–5 of the timer control/status register Reset control/status register	Bits 2–0 of the timer control/status register Timer counter	—
16-bit free-running timer (FRT)	All registers	—	—
Serial communication interface (SCI)	All registers	—	—
Others	—	Standby control register Frequency modification register	—

14.4.2 Canceling Standby Mode

Standby mode is canceled by an NMI interrupt, a power-on reset, or a manual reset.

Cancellation by an NMI: When a rising edge or falling edge is detected in the NMI signal, after the elapse of the time set in the WDT timer control/status register, clocks are supplied to the entire chip, standby mode is canceled, and NMI exception handling begins.

Cancellation by a Power-On Reset: A power-on reset cancels standby mode.

Cancellation by a Manual Reset: A manual reset cancels standby mode.

14.4.3 Standby Mode Cancellation by NMI

The following example describes moving to the standby mode upon the fall of the NMI signal and clearing the standby when the NMI signal rises. Figure 14.1 shows the timing.

When the NMI pin level changes from high to low after the NMI edge select bit (NMIE) of the interrupt control register (ICR) has been set to 0 (detect falling edge), an NMI interrupt is accepted. When the NMIE bit is set to 1 (detect rising edge) by the NMI exception service routine, the standby bit (SBY) of the standby control register (SBYCR) is set to 1 and a SLEEP instruction is executed, the standby mode is entered. The standby mode is cleared the next time the NMI pin level changes from low level to high level.

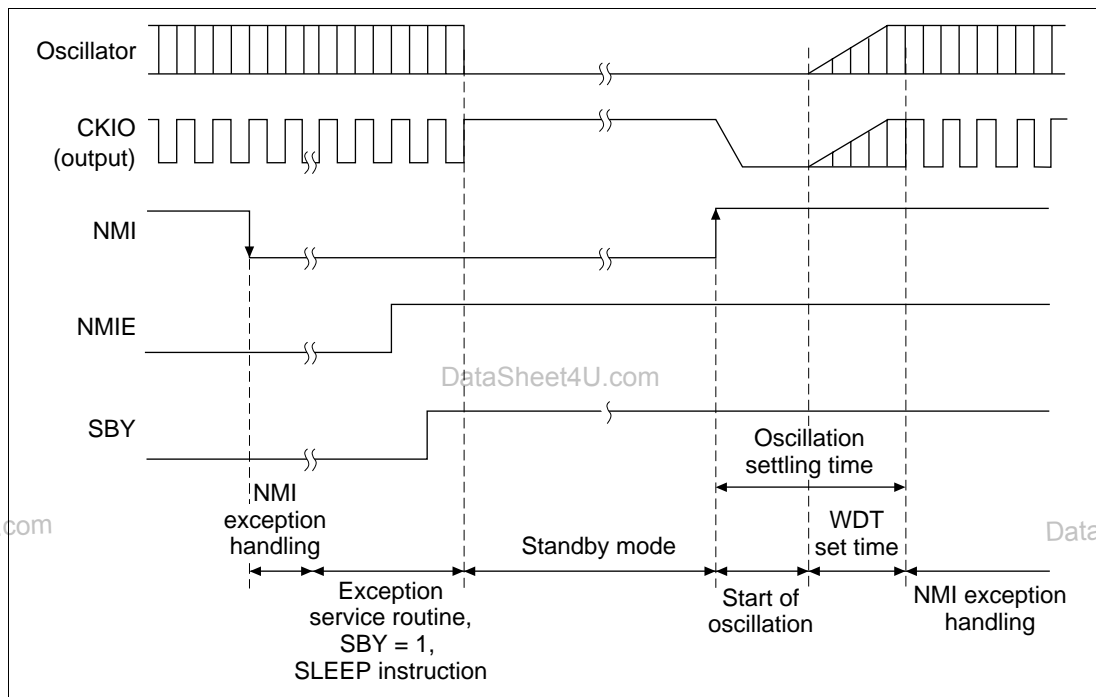

Figure 14.1 Standby Mode Cancellation by NMI

14.4.4 Clock Pause Function

When the clock is input from the CKIO pin, the clock frequency can be modified or the clock stopped. The SH7604 has a $\overline{\text{CKPREQ}}/\text{CKM}$ pin for this purpose. The clock pause function is used as described below. Note that clock pauses are not accepted while the watchdog timer (WDT) is operating (i.e. when the timer enable bit (TME) in the WDT's timer control/status register (WTCSR) is 1).

1. Set the TME bit in the watchdog timer's WTCSR register to 0.
2. Set the overflow time in bits CKS2 to CKS0 bits in the watchdog timer's WTCSR register (overflow time should be calculated using the clock frequency after modification).
3. After the SLEEP instruction is executed and standby mode is entered, apply a low level from the $\overline{\text{CKPREQ/CKM}}$ pin.
4. When the chip is internally ready to modify the operating clock, a low level is output from the $\overline{\text{CKPACK}}$ pin.
5. After the $\overline{\text{CKPACK}}$ pin goes low, the clocks are stopped and the frequency is modified. The internal chip state is the same as in standby mode.
6. When the clock pause state (standby) is canceled, the WDT starts to count up at the falling edge or rising edge of the NMI pin (when the NMIE bit of INTC is set).
7. When a frequency is modified, the $\overline{\text{CKPACK}}$ pin goes high after the time set by the WDT, and the clock pause function gives external notification that the chip can again be operated (standby mode is canceled).
8. When a clock is halted, the clock is applied again to the CKIO pin and NMI input is generated. After the time set by the WDT, the $\overline{\text{CKPACK}}$ pin goes high, and the clock pause function gives external notification that the chip can again be operated (standby mode is canceled).

The standby state, all internal functions and all pin states during clock pause are equivalent to those of the normal standby mode. Figure 14.2 shows the timing chart for the clock pause function.

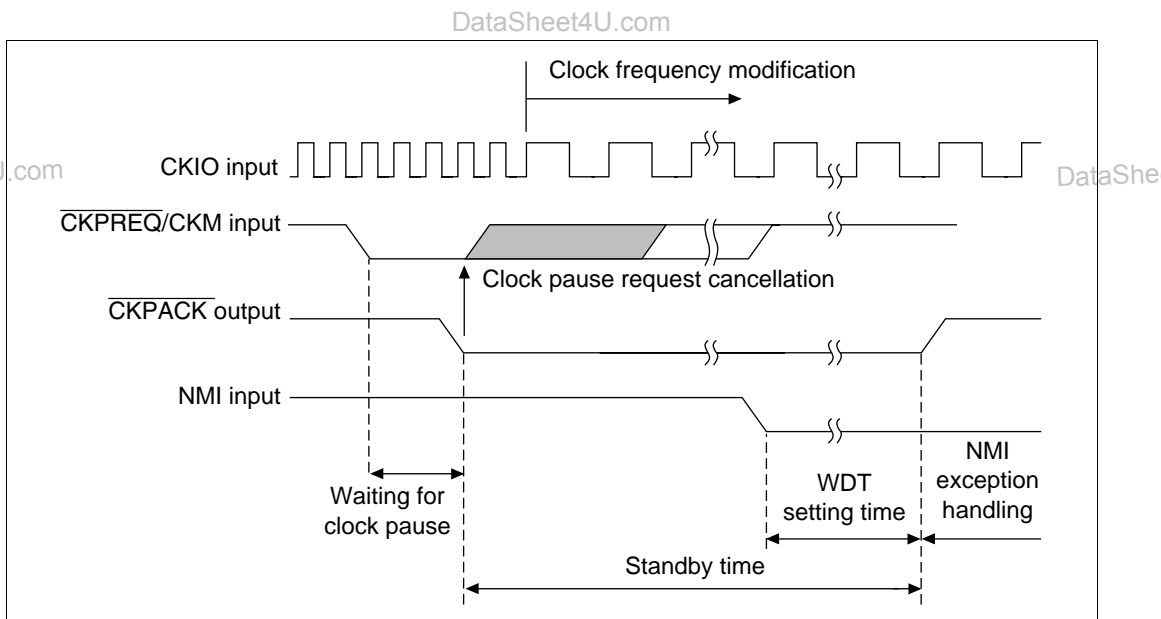

Figure 14.2 Clock Pause Function Timing

14.4.5 Notes on Standby Mode

1. When the SH7604 enters standby mode during use of the cache, disable the cache before making the mode transition. Initialize the cache beforehand when the cache is used after returning to standby mode. The contents of the on-chip RAM are not retained in standby mode when cache is used as on-chip RAM.
2. If an on-chip peripheral register is written in the 10 clock cycles before the SH7604 transits to standby mode, read the register before executing the SLEEP instruction.
3. When using clock mode 0, 1, or 2, the CKIO pin is the clock output pin. Note the following when standby mode is used in these clock modes. When standby mode is canceled by NMI, an unstable clock is output from the CKIO pin during the oscillation settling time after NMI input. This also applies to clock output in the case of cancellation by a power-on reset or manual reset. Power-on reset and manual reset input should be continued for a period at least equal to for the oscillation settling time.

14.5 Module Standby Function

14.5.1 Transition to Module Standby Function

By setting one of standby control register bits MSTP4–MSTP0 to 1, the supply of the clock to the corresponding on-chip peripheral module can be halted. This function can be used to reduce the power consumption in sleep mode. Do not perform read/write operations for a module in module standby mode.

The external pins and registers of the DMAC, MULT, and DIVU on-chip peripheral modules retain their states prior to halting. The external pins of the FRT and SCI are reset and all their registers are initialized.

Do not switch on-chip peripheral modules to module standby mode while they are running.

14.5.2 Clearing the Module Standby Function

Clear the module standby function by clearing the MSTP4–MSTP0 bits, or by a power-on reset or manual reset.

To effect a module stop, halt the relevant module or disable interrupts.

DataSheet4U.com

et4U.com

DataShee

DataSheet4U.com

www.DataSheet4U.com

Section 15 Electrical Characteristics (5V Version)

15.1 Absolute Maximum Ratings

Table 15.1 shows the absolute maximum ratings.

Table 15.1 Absolute Maximum Ratings

Item	Symbol	Rating	Unit
Power supply voltage	V_{CC}	-0.3 to +7.0	V
Input voltage	V_{in}	-0.3 to $V_{CC} + 0.3$	V
Operating temperature	T_{opr}	-20 to +75	°C
Storage temperature	T_{stg}	-55 to +125	°C

Caution: Operating the chip in excess of the absolute maximum rating may result in permanent damage.

DataSheet4U.com

et4U.com

DataShee

DataSheet4U.com

www.DataSheet4U.com

DataSheet4U.com

15.2 DC Characteristics

Tables 15.2 and 15.3 list DC characteristics.

Table 15.2 DC Characteristics (Conditions: $V_{CC} = 5.0\text{ V} \pm 10\%$, $T_a = -20$ to $+75^\circ\text{C}$)

Item	Symbol	Min	Typ	Max	Unit	Test Conditions	
Input high-level voltage	$\overline{\text{RES}}$, NMI, MD5–MD0	V_{IH}	$V_{CC} - 0.5$	—	$V_{CC} + 0.3$	V	During standby
			$V_{CC} - 0.7$	—	$V_{CC} + 0.3$	V	Normal operation
	EXTAL, CKIO	$V_{CC} - 0.7$	—	$V_{CC} + 0.3$	V		
	Other input pins	2.2	—	$V_{CC} + 0.3$	V		
Input low-level voltage	$\overline{\text{RES}}$, NMI, MD5–MD0	V_{IL}	-0.3	—	0.5	V	During standby
			-0.3	—	0.8	V	Normal operation
	Other input pins	-0.3	—	0.8	V		
Input leak current	$\overline{\text{RES}}$	$ I_{in} $	—	—	1.0	μA	$V_{in} = 0.5$ to $V_{CC} - 0.5\text{ V}$
	NMI, MD5–MD0		—	—	1.0	μA	$V_{in} = 0.5$ to $V_{CC} - 0.5\text{ V}$
	Other input pins		—	—	1.0	μA	$V_{in} = 0.5$ to $V_{CC} - 0.5\text{ V}$
3-state leak current (while off)	A26–A0, D31–D0, $\overline{\text{BS}}$, CS3–CS0, RD/ $\overline{\text{WR}}$, $\overline{\text{RAS}}$, $\overline{\text{CAS}}$, WE3–WE0, $\overline{\text{RD}}$, IVECF	$ I_{ST} $	—	—	1.0	μA	$V_{in} = 0.5$ to $V_{CC} - 0.5\text{ V}$
Output high-level voltage	All output pins	V_{OH}	$V_{CC} - 0.5$	—	—	V	$I_{OH} = -200\ \mu\text{A}$
			3.5	—	—	V	$I_{OH} = -1\ \text{mA}$
Output low-level voltage	All output pins	V_{OL}	—	—	0.4	V	$I_{OL} = 1.6\ \text{mA}$
Input capacitance	$\overline{\text{RES}}$	Cin	—	—	15	pF	$V_{in} = 0\ \text{V}$
	NMI		—	—	15	pF	$f = 1\ \text{MHz}$
	All other input pins (including D31–D0)		—	—	15	pF	$T_a = 25^\circ\text{C}$

Table 15.2 DC Characteristics (Conditions: $V_{CC} = 5.0\text{ V} \pm 10\%$, $T_a = -20$ to $+75^\circ\text{C}$) (cont)

Item	Symbol	Min	Typ	Max	Unit	Test Conditions
Current consumption	Normal operation	I_{CC}	—	60	80	mA $f = 8\text{ MHz}$
			—	80	100	mA $f = 16\text{ MHz}$
			—	110	160	mA $f = 28.7\text{ MHz}$
	Sleep	—	—	30	55	mA $f = 8\text{ MHz}$
			—	50	70	mA $f = 16\text{ MHz}$
			—	80	100	mA $f = 28.7\text{ MHz}$
Standby	—	—	1	15	μA $T_a \leq 50^\circ\text{C}$	
		—	—	60	μA $50^\circ\text{C} < T_a$	

- Notes: 1. When no PLL is used, do not leave the PLLV_{CC} and PLLV_{SS} pins open. Connect PLLV_{CC} to V_{CC} and PLLV_{SS} to V_{SS}.
2. Current consumption values shown are the values at which all output pins are without load under conditions of $V_{IH\text{ min}} = V_{CC} - 0.5\text{ V}$, $V_{IL\text{ max}} = 0.5\text{ V}$.

Table 15.3 Permitted Output Current Values (Conditions: $V_{CC} = 5.0\text{ V} \pm 10\%$, $T_a = -20$ to $+75^\circ\text{C}$)

Item	Symbol	Min	Typ	Max	Unit
Output low-level permissible current (per pin)	I_{OL}	—	—	2.0	mA
Output low-level permissible current (total)	ΣI_{OL}	—	—	80	mA
Output high-level permissible current (per pin)	$-I_{OH}$	—	—	2.0	mA
Output high-level permissible current (total)	$\Sigma(-I_{OH})$	—	—	25	mA

Caution: To ensure chip reliability, do not exceed the output current values given in table 15.3.

15.3 AC Characteristics

15.3.1 Clock Timing

Table 15.4 Clock Timing (Conditions: $V_{CC} = 5.0\text{ V} \pm 10\%$, $T_a = -20$ to $+75^\circ\text{C}$)

Item	Symbol	Min	Max	Unit	Figures
Operating frequency	f_{OP}	4	28.7	MHz	15.1
Clock cycle time	t_{cyc}	35	143^{*1} or 250^{*2}	ns	
Clock high pulse width	t_{CH}	8^{*1} or 15^{*2}	—	ns	
Clock low pulse width	t_{CL}	8^{*1} or 15^{*2}	—	ns	
Clock rise time	t_{CR}	—	5	ns	
Clock fall time	t_{CF}	—	5	ns	
EXTAL clock input frequency	f_{EX}	4	8	MHz	15.2
EXTAL clock input cycle time	t_{EXcyc}	125	250	ns	
EXTAL clock input low-level pulse width	t_{EXL}	50	—	ns	
EXTAL clock input high-level pulse width	t_{EXH}	50	—	ns	
EXTAL clock input rise time	t_{EXR}	—	5	ns	
EXTAL clock input clock fall time	t_{EXF}	—	5	ns	
Power-on oscillation settling time	t_{OSC1}	10	—	ms	15.3
Software standby oscillation settling time 1	t_{OSC2}	10	—	ms	15.4
Software standby oscillation settling time 2	t_{OSC3}	10	—	ms	15.5
PLL synchronization settling time	t_{PLL}	1	—	μs	15.6

Notes: 1. With PLL circuit 1 operating.
2. With PLL circuit 1 not used.

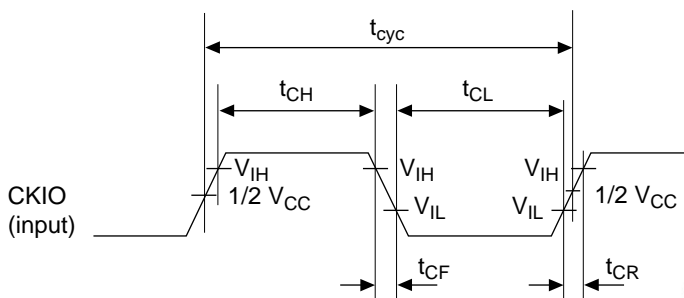
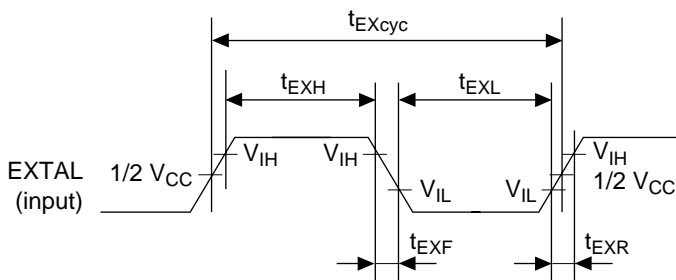
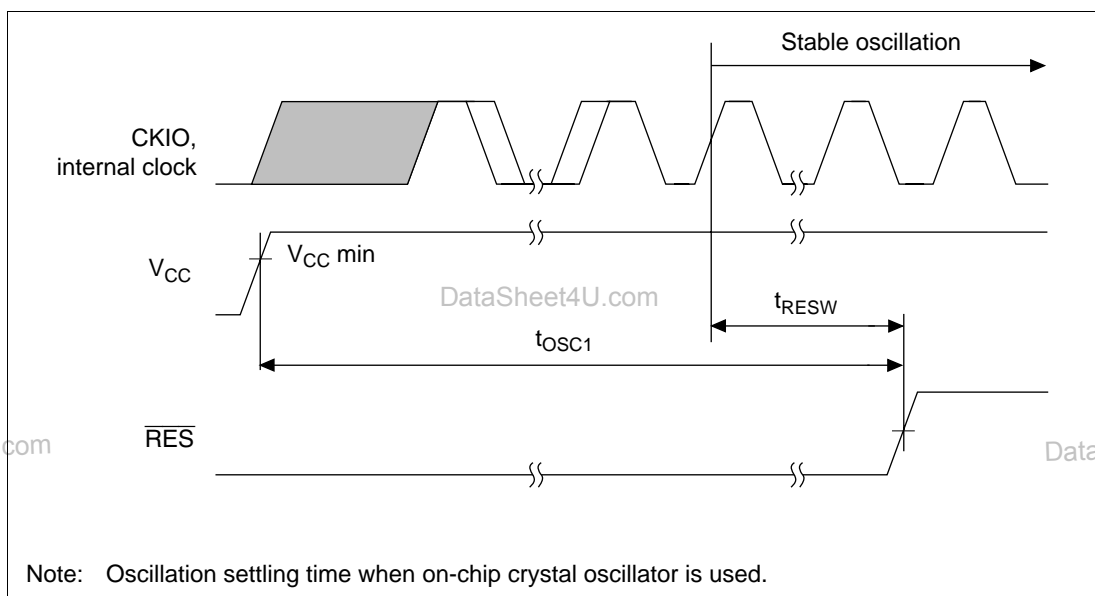

Figure 15.1 CKIO Input Timing



Note: External clock input from EXTAL pin.

Figure 15.2 EXTERNAL CLOCK INPUT Timing



Note: Oscillation settling time when on-chip crystal oscillator is used.

Figure 15.3 Oscillation Settling Time at Power-On

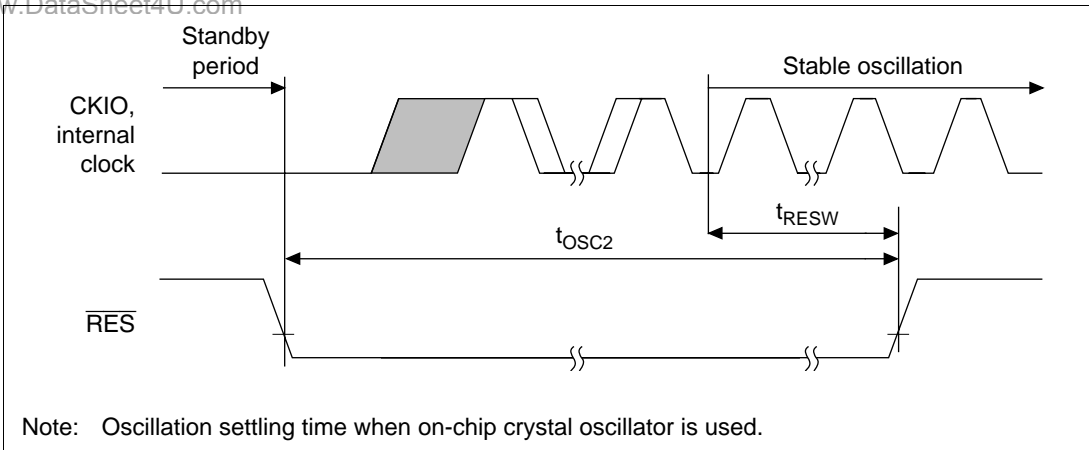

Figure 15.4 Oscillation Settling Time at Standby Return (via \overline{RES})

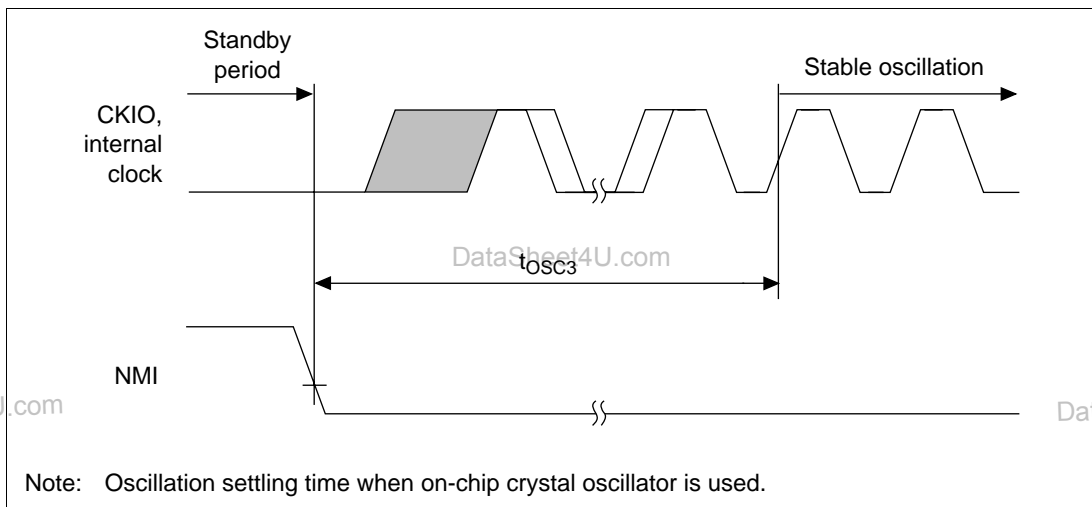

Figure 15.5 Oscillation Settling Time at Standby Return (via NMI)

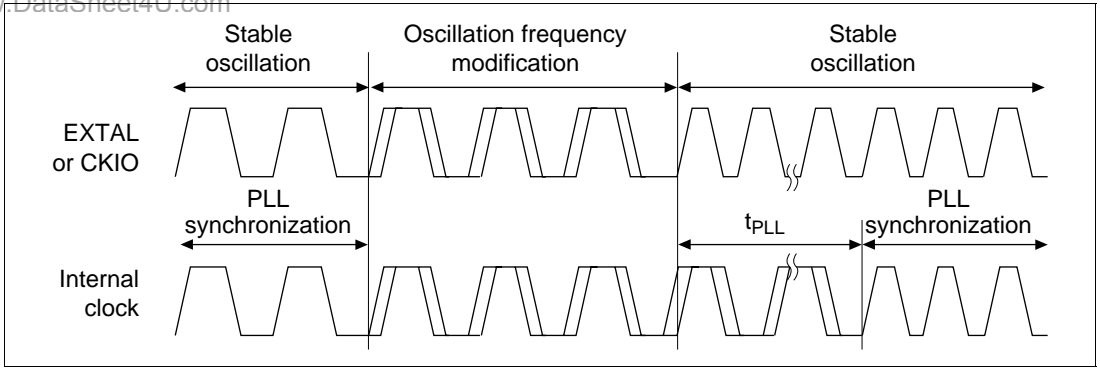

Figure 15.6 PLL Synchronization Settling Time

DataSheet4U.com

et4U.com

DataShee

DataSheet4U.com

www.DataSheet4U.com

DataSheet4U.com

Table 15.5 Control Signal Timing (Conditions: $V_{CC} = 5.0 \text{ V} \pm 10\%$, $T_a = -20$ to $+75^\circ\text{C}$)

Item	Symbol	Min	Max	Unit	Figure
$\overline{\text{RES}}$ rise, fall	t_{RESr} , t_{RESf}	—	200	ns	15.7
$\overline{\text{RES}}$ pulse width	t_{RESW}	20	—	t_{cyc}	
NMI reset setup time	t_{NMIRS}	$t_{\text{cyc}} + 10$	—	ns	
NMI reset hold time	t_{NMIRH}	$t_{\text{cyc}} + 10$	—	ns	
NMI rise, fall	t_{NMIr} , t_{NMIf}	—	200	ns	
NMI minimum pulse width	t_{IRQES}	3	—	t_{cyc}	
$\overline{\text{RES}}$ setup time*	t_{RESS}	30	—	ns	15.8,
NMI setup time*	t_{NMIS}	30	—	ns	15.9
$\overline{\text{IRL3}}\text{--}\overline{\text{IRL0}}$ setup time*	t_{IRLS}	30	—	ns	
$\overline{\text{RES}}$ hold time	t_{RESH}	10	—	ns	15.8,
NMI hold time	t_{NMIH}	10	—	ns	15.9
$\overline{\text{IRL3}}\text{--}\overline{\text{IRL0}}$ hold time	t_{IRLH}	10	—	ns	
$\overline{\text{BRLS}}$ setup time 1 (PLL on)	t_{BLSS1}	$1/2 t_{\text{cyc}} + 9$	—	ns	15.10
$\overline{\text{BRLS}}$ hold time 1 (PLL on)	t_{BLSH1}	$9 - 1/2 t_{\text{cyc}}$	—	ns	
$\overline{\text{BGR}}$ delay time 1 (PLL on)	t_{BGRD1}	—	$1/2 t_{\text{cyc}} + 18$	ns	
$\overline{\text{BRLS}}$ setup time 1 (PLL on, 1/4 cycle delay)	t_{BLSS1}	$1/4 t_{\text{cyc}} + 9$	—	ns	15.10
$\overline{\text{BRLS}}$ hold time 1 (PLL on, 1/4 cycle delay)	t_{BLSH1}	$9 - 1/4 t_{\text{cyc}}$	—	ns	
$\overline{\text{BGR}}$ delay time 1 (PLL on, 1/4 cycle delay)	t_{BGRD1}	—	$3/4 t_{\text{cyc}} + 18$	ns	
$\overline{\text{BRLS}}$ setup time 2 (PLL off)	t_{BLSS2}	9	—	ns	15.11
$\overline{\text{BRLS}}$ hold time 2 (PLL off)	t_{BLSH2}	19	—	ns	
$\overline{\text{BGR}}$ delay time 2 (PLL off)	t_{BGRD2}	—	28	ns	

Note: The $\overline{\text{RES}}$, NMI and $\overline{\text{IRL3}}\text{--}\overline{\text{IRL0}}$ signals are asynchronous inputs, but when the setup times shown here are observed, the signals are considered to have changed at clock fall. If the setup times are not observed, recognition may be delayed until the next clock fall.

Table 15.5 Control Signal Timing (Conditions: $V_{CC} = 5.0\text{ V} \pm 10\%$, $T_a = -20\text{ to }+75^\circ\text{C}$)
(cont)

Item	Symbol	Min	Max	Unit	Figure
$\overline{\text{BREQ}}$ delay time 1 (PLL on)	t_{BRQD1}	—	$1/2\text{ tcyc} + 18$	ns	15.12
$\overline{\text{BACK}}$ setup time 1 (PLL on)	t_{BAKS1}	$1/2\text{ tcyc} + 9$	—	ns	
$\overline{\text{BACK}}$ hold time 1 (PLL on)	t_{BAKH1}	$9 - 1/2\text{ tcyc}$	—	ns	
$\overline{\text{BREQ}}$ delay time 1 (PLL on, 1/4 cycle delay)	t_{BRQD1}	—	$3/4\text{ tcyc} + 18$	ns	15.12
$\overline{\text{BACK}}$ setup time 1 (PLL on, 1/4 cycle delay)	t_{BAKS1}	$1/4\text{ tcyc} + 9$	—	ns	
$\overline{\text{BACK}}$ hold time 1 (PLL on, 1/4 cycle delay)	t_{BAKH1}	$9 - 1/4\text{ tcyc}$	—	ns	
$\overline{\text{BREQ}}$ delay time 2 (PLL off)	t_{BRQD2}	—	28	ns	15.13
$\overline{\text{BACK}}$ setup time 2 (PLL off)	t_{BAKS2}	9	—	ns	
$\overline{\text{BACK}}$ hold time 2 (PLL off)	t_{BAKH2}	19	—	ns	
Bus tri-state delay time 1 (PLL on)	t_{BOFF1}	0	25	ns	15.10,
Bus buffer on time 1 (PLL on)	t_{BON1}	0	18	ns	15.12
Bus tri-state delay time 1 (PLL on, 1/4 cycle delay)	t_{BOFF1}	$1/4\text{ tcyc}$	$1/4\text{ tcyc} + 25$	ns	15.10,
Bus buffer on time 1 (PLL on, 1/4 cycle delay)	t_{BON1}	$1/4\text{ tcyc}$	$1/4\text{ tcyc} + 18$	ns	15.12
Bus tri-state delay time 1 (PLL off)	t_{BOFF1}	0	30	ns	15.11,
Bus buffer on time 1 (PLL off)	t_{BON1}	0	25	ns	15.13
Bus tri-state delay time 2 (PLL on)	t_{BOFF2}	$1/2\text{ tcyc}$	$1/2\text{ tcyc} + 25$	ns	15.10,
Bus buffer on time 2 (PLL on)	t_{BON2}	$1/2\text{ tcyc}$	$1/2\text{ tcyc} + 18$	ns	15.12
Bus tri-state delay time 2 (PLL on, 1/4 cycle delay)	t_{BOFF2}	$3/4\text{ tcyc}$	$3/4\text{ tcyc} + 25$	ns	15.10,
Bus buffer on time 2 (PLL on, 1/4 cycle delay)	t_{BON2}	$3/4\text{ tcyc}$	$3/4\text{ tcyc} + 18$	ns	15.12
Bus tri-state delay time 3 (PLL off)	t_{BOFF3}	0	30	ns	15.11,
Bus buffer on time 3 (PLL off)	t_{BON3}	0	25	ns	15.13

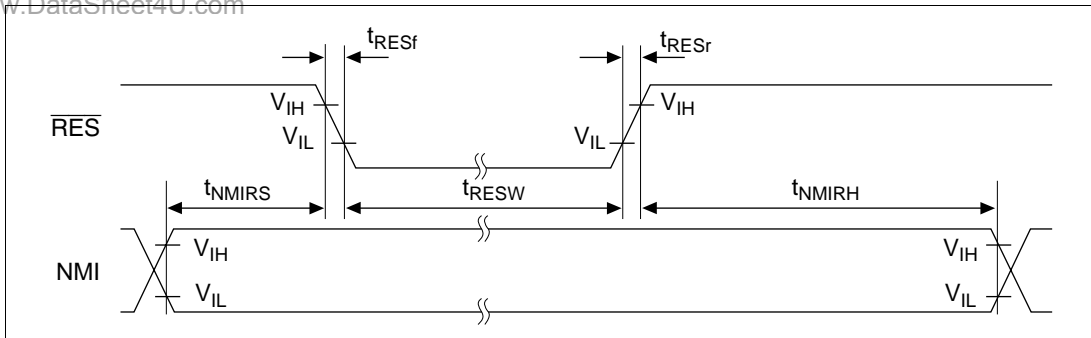

Figure 15.7 Reset Input Timing

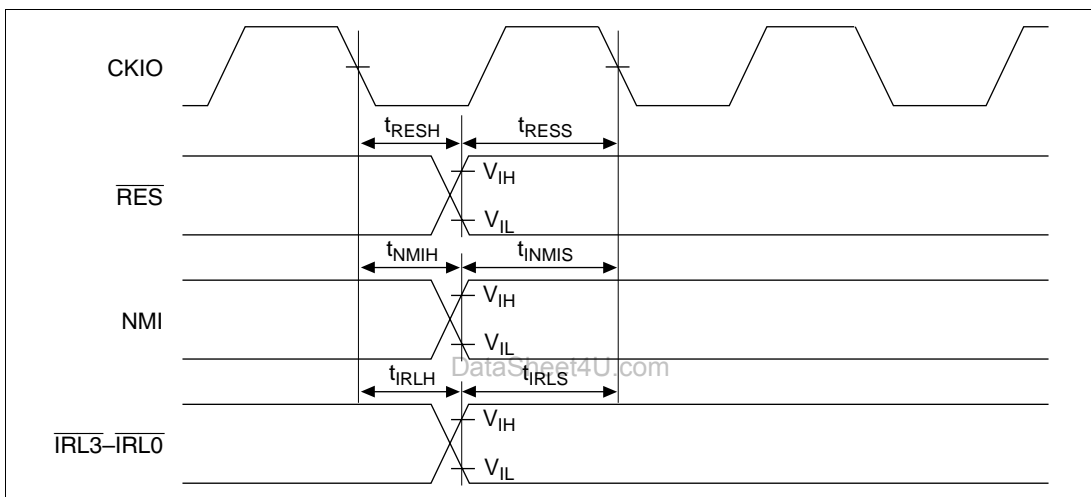

Figure 15.8 Interrupt Signal Input Timing (With PLL1 Off)

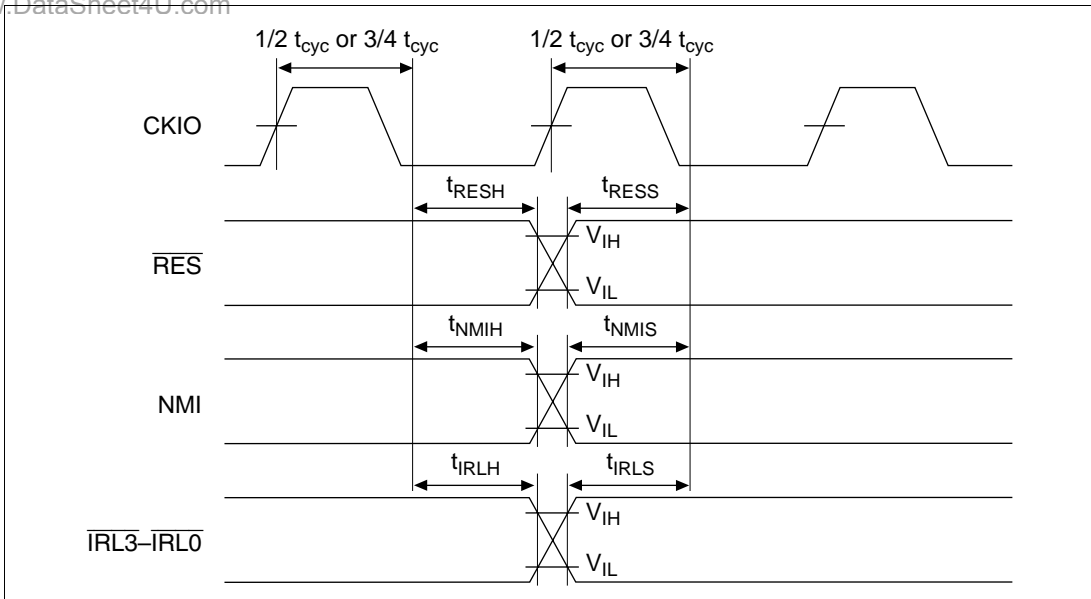

Figure 15.9 Interrupt Signal Input Timing (PLL1 On)

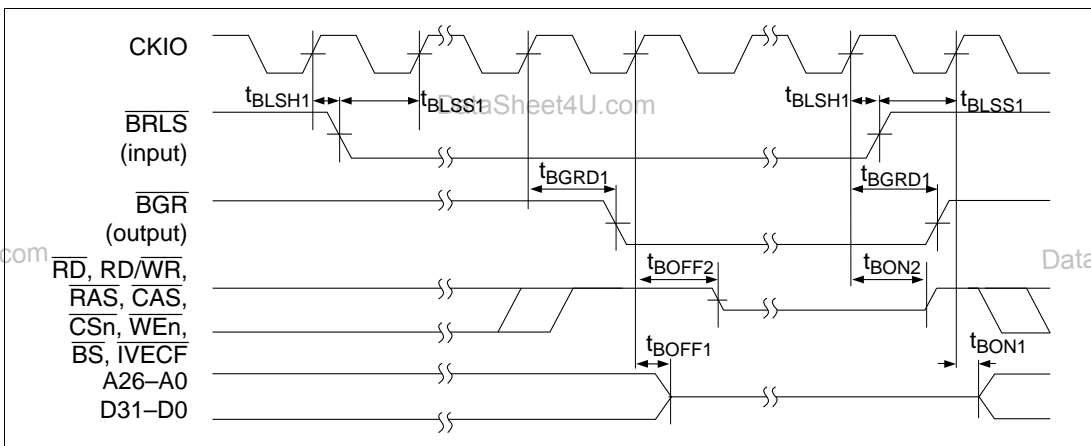

Figure 15.10 Bus Release Timing (Master Mode, PLL1 On)

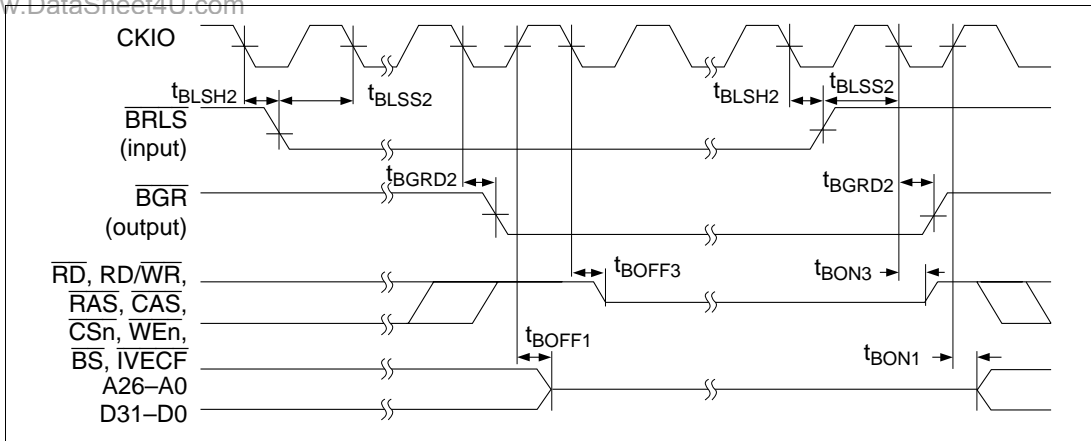

Figure 15.11 Bus Release Timing (Master Mode, PLL1 Off)

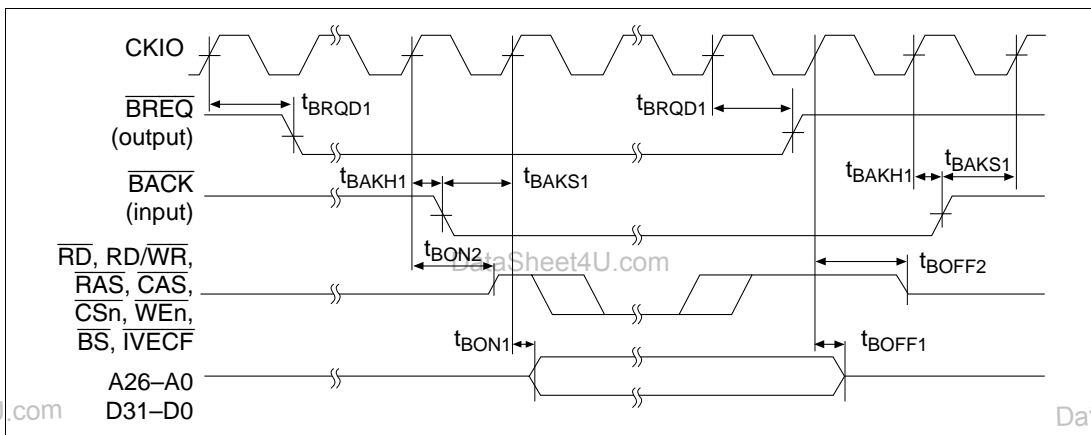

Figure 15.12 Bus Release Timing (Slave Mode, PLL1 On)

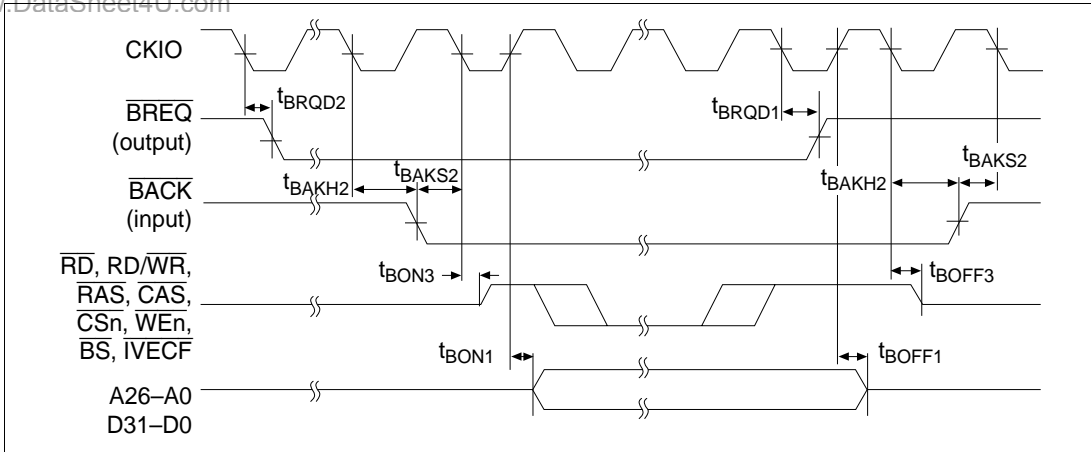

Figure 15.13 Bus Release Timing (Slave Mode, PLL1 Off)

DataSheet4U.com

et4U.com

DataShee

DataSheet4U.com

www.DataSheet4U.com

DataSheet4U.com

**Table 15.6 Bus Timing With PLL On [Mode 0, 4] (Conditions: $V_{CC} = 5.0\text{ V} \pm 10\%$,
 $T_a = -20$ to $+75^\circ\text{C}$)**

Item	Symbol	Min	Max	Unit	Figures
Address delay time	t_{AD}	3	18	ns	15.14, 15.20, 15.40, 15.52, 15.66, 15.68
\overline{BS} delay time	t_{BSD}	—	21	ns	15.14, 15.20, 15.40, 15.52, 15.66
\overline{CS} delay time 1	t_{CSD1}	—	21	ns	15.14, 15.20, 15.40, 15.52, 15.66
\overline{CS} delay time 2	t_{CSD2}	—	$1/2 t_{cyc} + 21$	ns	15.14, 15.66
Read/write delay time	t_{RWD}	3	18	ns	15.14, 15.20, 15.40, 15.52, 15.66
Read strobe delay time 1	t_{RSD1}	—	$1/2 t_{cyc} + 16$	ns	15.14, 15.40, 15.52, 15.66, 15.68
Read data setup time 1	t_{RDS1}	$1/2 t_{cyc} + 10$	—	ns	15.14, 15.40, 15.52, 15.66, 15.68
Read data setup time 3 (SDRAM)	t_{RDS3}	$1/2 t_{cyc} + 8$	—	ns	15.20
Read data hold time 2	t_{RDH2}	0	—	ns	15.14, 15.66
Read data hold time 4 (SDRAM)	t_{RDH4}	0	—	ns	15.20
Read data hold time 5 (DRAM)	t_{RDH5}	0	—	ns	15.40
Read data hold time 6 (PSRAM)	t_{RDH6}	0	—	ns	15.52
Read data hold time 7 (interrupt vector)	t_{RDH7}	0	—	ns	15.68
Write enable delay time	t_{WED1}	$1/2 t_{cyc} + 3$	$1/2 t_{cyc} + 18$	ns	15.14, 15.15, 15.52, 15.53
Write data delay time 1	t_{WDD}	3	18	ns	15.15, 15.27, 15.41, 15.53
Write data hold time 1	t_{WDH1}	3	—	ns	15.15, 15.27, 15.41, 15.53
Data buffer on time	t_{DON}	—	18	ns	15.15, 15.27, 15.41, 15.53
Data buffer off time	t_{DOF}	—	18	ns	15.15, 15.27, 15.41, 15.53

Table 15.6 Bus Timing With PLL On [Mode 0, 4] (cont)(Conditions: $V_{CC} = 5.0\text{ V} \pm 10\%$, $T_a = -20\text{ to }+75^\circ\text{C}$)

Item	Symbol	Min	Max	Unit	Figures
DACK delay time 1	t_{DACD1}	—	18	ns	15.14, 15.20, 15.40, 15.52, 15.66
DACK delay time 2	t_{DACD2}	—	$1/2\text{ }t_{cyc} + 18$	ns	15.14, 15.20, 15.40, 15.52, 15.66
WAIT setup time	t_{WTS}	20	—	ns	15.19, 15.43, 15.55, 15.66, 15.70
WAIT hold time	t_{WTH}	5	—	ns	15.19, 15.43, 15.55, 15.66, 15.70
$\overline{\text{RAS}}$ delay time 1 (SDRAM)	t_{RASD1}	—	18	ns	15.20
$\overline{\text{RAS}}$ delay time 2 (DRAM)	t_{RASD2}	$1/2\text{ }t_{cyc} + 3$	$1/2\text{ }t_{cyc} + 18$	ns	15.40
$\overline{\text{CAS}}$ delay time 1 (SDRAM)	t_{CASD1}	—	18	ns	15.20
$\overline{\text{CAS}}$ delay time 2 (DRAM)	t_{CASD2}	$1/2\text{ }t_{cyc} + 3$	$1/2\text{ }t_{cyc} + 18$	ns	15.40
DQM delay time	t_{DQMD}	—	18	ns	15.20
CKE delay time	t_{CKED}	—	21	ns	15.37
$\overline{\text{CE}}$ delay time 1	t_{CED1}	$1/2\text{ }t_{cyc} + 3$	$1/2\text{ }t_{cyc} + 18$	ns	15.52
$\overline{\text{OE}}$ delay time 1	t_{OED1}	—	$1/2\text{ }t_{cyc} + 18$	ns	15.52
$\overline{\text{IVECF}}$ delay time	t_{IVD}	—	18	ns	15.68
Address input setup time	t_{ASIN}	14	—	ns	15.71
Address input hold time	t_{AHIN}	3	—	ns	15.71
$\overline{\text{BS}}$ input setup time	t_{BSS}	15	—	ns	15.71
$\overline{\text{BS}}$ input hold time	t_{BSH}	3	—	ns	15.71
Read/write input setup time	t_{RWS}	15	—	ns	15.71
Read/write input hold time	t_{RWH}	3	—	ns	15.71
Address hold time 1	t_{AH1}	5	—	ns	15.15

Table 15.7 Bus Timing With PLL On and 1/4 Cycle Delay [Mode 1, 5](Conditions: $V_{CC} = 5.0\text{ V} \pm 10\%$, $T_a = -20\text{ to }+75^\circ\text{C}$)

Item	Symbol	Min	Max	Unit	Figures
Address delay time	t_{AD}	$1/4\text{ tcyc} + 3$	$1/4\text{ tcyc} + 18$	ns	15.14, 15.20, 15.40, 15.52, 15.66, 15.68
\overline{BS} delay time	t_{BSD}	—	$1/4\text{ tcyc} + 21$	ns	15.14, 15.20, 15.40, 15.52, 15.66
\overline{CS} delay time 1	t_{CSD1}	—	$1/4\text{ tcyc} + 21$	ns	15.14, 15.20, 15.40, 15.52, 15.66
\overline{CS} delay time 2	t_{CSD2}	—	$3/4\text{ tcyc} + 21$	ns	15.14, 15.66
Read/write delay time	t_{RWD}	$1/4\text{ tcyc} + 3$	$1/4\text{ tcyc} + 18$	ns	15.14, 15.20, 15.40, 15.52, 15.66
Read strobe delay time 1	t_{RSD1}	—	$3/4\text{ tcyc} + 16$	ns	15.14, 15.40, 15.52, 15.66, 15.68
Read data setup time 1	t_{RDS1}	$1/4\text{ tcyc} + 10$	—	ns	15.14, 15.40, 15.52, 15.66, 15.68
Read data setup time 3 (SDRAM)	t_{RDS3}	$1/4\text{ tcyc} + 8$	—	ns	15.20
Read data hold time 2	t_{RDH2}	0	—	ns	15.14, 15.66
Read data hold time 4 (SDRAM)	t_{RDH4}	0	—	ns	15.20
Read data hold time 5 (DRAM)	t_{RDH5}	0	—	ns	15.40
Read data hold time 6 (PSRAM)	t_{RDH6}	0	—	ns	15.52
Read data hold time 7 (interrupt vector)	t_{RDH7}	0	—	ns	15.68
Write enable delay time	t_{WED1}	$3/4\text{ tcyc} + 3$	$3/4\text{ tcyc} + 18$	ns	15.14, 15.15, 15.52, 15.53
Write data delay time 1	t_{WDD}	$1/4\text{ tcyc} + 3$	$1/4\text{ tcyc} + 18$	ns	15.15, 15.27, 15.41, 15.53
Write data hold time 1	t_{WDH1}	$1/4\text{ tcyc} + 3$	—	ns	15.15, 15.27, 15.41, 15.53
Data buffer on time	t_{DON}	—	$1/4\text{ tcyc} + 18$	ns	15.15, 15.27, 15.41, 15.53
Data buffer off time	t_{DOF}	—	$1/4\text{ tcyc} + 18$	ns	15.15, 15.27, 15.41, 15.53

Table 15.7 Bus Timing With PLL On and 1/4 Cycle Delay [Mode 1, 5] (cont)(Conditions: $V_{CC} = 5.0\text{ V} \pm 10\%$, $T_a = -20\text{ to }+75^\circ\text{C}$)

Item	Symbol	Min	Max	Unit	Figures
DACK delay time 1	t_{DACD1}	—	$1/4\text{ tcyc} + 18$	ns	15.14, 15.20, 15.40, 15.52, 15.66
DACK delay time 2	t_{DACD2}	—	$3/4\text{ tcyc} + 18$	ns	15.14, 15.20, 15.40, 15.52, 15.66
$\overline{\text{WAIT}}$ setup time	t_{WTS}	$20 - 1/4\text{ tcyc}$	—	ns	15.19, 15.43, 15.55, 15.66, 15.70
$\overline{\text{WAIT}}$ hold time	t_{WTH}	$1/4\text{ tcyc} + 5$	—	ns	15.19, 15.43, 15.55, 15.66, 15.70
$\overline{\text{RAS}}$ delay time 1 (SDRAM)	t_{RASD1}	—	$1/4\text{ tcyc} + 18$	ns	15.20
$\overline{\text{RAS}}$ delay time 2 (DRAM)	t_{RASD2}	$3/4\text{ tcyc} + 3$	$3/4\text{ tcyc} + 18$	ns	15.40
$\overline{\text{CAS}}$ delay time 1 (SDRAM)	t_{CASD1}	—	$1/4\text{ tcyc} + 18$	ns	15.20
$\overline{\text{CAS}}$ delay time 2 (DRAM)	t_{CASD2}	$3/4\text{ tcyc} + 3$	$3/4\text{ tcyc} + 18$	ns	15.40
DQM delay time	t_{DQMD}	—	$1/4\text{ tcyc} + 18$	ns	15.20
CKE delay time	t_{CKED}	—	$1/4\text{ tcyc} + 21$	ns	15.37
$\overline{\text{CE}}$ delay time 1	t_{CED1}	$3/4\text{ tcyc} + 3$	$3/4\text{ tcyc} + 18$	ns	15.52
$\overline{\text{OE}}$ delay time 1	t_{OED1}	—	$3/4\text{ tcyc} + 18$	ns	15.52
$\overline{\text{IVECF}}$ delay time	t_{IVD}	—	$1/4\text{ tcyc} + 18$	ns	15.68
Address input setup time	t_{ASIN}	$14 - 1/4\text{ tcyc}$	—	ns	15.71
Address input hold time	t_{AHIN}	$1/4\text{ tcyc} + 3$	—	ns	15.71
$\overline{\text{BS}}$ input setup time	t_{BSS}	$15 - 1/4\text{ tcyc}$	—	ns	15.71
$\overline{\text{BS}}$ input hold time	t_{BSH}	$1/4\text{ tcyc} + 3$	—	ns	15.71
Read/write input setup time	t_{RWS}	$15 - 1/4\text{ tcyc}$	—	ns	15.71
Read/write input hold time	t_{RWH}	$1/4\text{ tcyc} + 3$	—	ns	15.71
Address hold time 1	t_{AH1}	5	—	ns	15.15

Table 15.8 Bus Timing With PLL Off (CKIO Input) [Mode 6]
 (Conditions: $V_{CC} = 5.0\text{ V} \pm 10\%$, $T_a = -20\text{ to }+75^\circ\text{C}$)

Item	Symbol	Min	Max	Unit	Figures
Address delay time	t_{AD}	13	28	ns	15.16, 15.38, 15.47, 15.60, 15.67, 15.69
\overline{BS} delay time	t_{BSD}	—	30	ns	15.16, 15.38, 15.47, 15.60, 15.67
\overline{CS} delay time 1	t_{CSD1}	—	30	ns	15.16, 15.38, 15.47, 15.60, 15.67
\overline{CS} delay time 3	t_{CSD3}	—	28	ns	15.16, 15.67
Read write delay time	t_{RWD}	13	28	ns	15.16, 15.38, 15.47, 15.60, 15.67
Read strobe delay time 2	t_{RSD2}	—	26	ns	15.16, 15.47, 15.60, 15.67, 15.69
Read data setup time 2	t_{RDS2}	10	—	ns	15.16, 15.38, 15.47, 15.60, 15.67, 15.69
Read data hold time 2	t_{RDH2}	0	—	ns	15.16, 15.67
Read data hold time 3	t_{RDH3}	15	—	ns	15.38
Read data hold time 5 (DRAM)	t_{RDH5}	0	—	ns	15.47
Read data hold time 6 (PSRAM)	t_{RDH6}	0	—	ns	15.60
Read data hold time 7 (interrupt vector)	t_{RDH7}	0	—	ns	15.69
Write enable delay time 2	t_{WED2}	10	25	ns	15.17, 15.61
Write data delay time	t_{WDD}	10	25	ns	15.17, 15.39, 15.48, 15.61
Write data hold time 1	t_{WDH1}	3	—	ns	15.17, 15.39, 15.48, 15.61
Write data hold time 2	t_{WDH2}	5	—	ns	15.17
Write data hold time 3	t_{WDH3}	3	—	ns	15.61
DACK delay time 1	t_{DACD1}	—	25	ns	15.16, 15.38, 15.47, 15.60, 15.67
DACK delay time 3	t_{DACD3}	—	25	ns	15.16, 15.38, 15.47, 15.60, 15.67

Table 15.8 Bus Timing With PLL Off (CKIO Input) [Mode 6] (cont)
(Conditions: $V_{CC} = 5.0\text{ V} \pm 10\%$, $T_a = -20$ to $+75^\circ\text{C}$)

Item	Symbol	Min	Max	Unit	Figures
WAIT setup time	t_{WTS}	20	—	ns	15.19, 15.43, 15.55, 15.67, 15.70
WAIT hold time	t_{WTH}	15	—	ns	15.19, 15.43, 15.55, 15.67, 15.70
$\overline{\text{RAS}}$ delay time 1 (SDRAM)	t_{RASD1}	—	25	ns	15.38
$\overline{\text{RAS}}$ delay time 3 (DRAM)	t_{RASD3}	10	25	ns	15.47
$\overline{\text{CAS}}$ delay time 1 (SDRAM)	t_{CASD1}	—	25	ns	15.38
$\overline{\text{CAS}}$ delay time 3 (DRAM)	t_{CASD3}	10	25	ns	15.47
DQM delay time	t_{DQMD}	—	25	ns	15.38
CKE delay time	t_{CKED}	—	25	ns	15.37
$\overline{\text{CE}}$ delay time 2	t_{CED2}	10	25	ns	15.60
$\overline{\text{OE}}$ delay time 2	t_{OED2}	—	25	ns	15.60
$\overline{\text{IVECF}}$ delay time	t_{IVD}	—	25	ns	15.69
$\overline{\text{WE}}$ setup time	t_{WES1}	0	—	ns	15.16
Address setup time 1	t_{AS1}	0	—	ns	15.17
Address setup time 2	t_{AS2}	3	—	ns	15.60
Address hold time 2	t_{AH2}	0	—	ns	15.17
Row address setup time	t_{ASR}	3	—	ns	15.47
Column address setup time	t_{ASC}	3	—	ns	15.47
Write command setup time	t_{WCS}	3	—	ns	15.48
Write data setup time	t_{WDS}	3	—	ns	15.48
Address input setup time*	t_{ASIN}	15	—	ns	15.71
Address input hold time*	t_{AHIN}	10	—	ns	15.71
$\overline{\text{BS}}$ input setup time*	t_{BSS}	15	—	ns	15.71
$\overline{\text{BS}}$ input hold time*	t_{BSH}	10	—	ns	15.71
Read/write input setup time*	t_{RWS}	15	—	ns	15.71
Read/write input hold time*	t_{RWH}	10	—	ns	15.71
Data buffer on time	t_{DON}	—	25	ns	15.17, 15.39, 15.48, 15.61
Data buffer off time	t_{DOF}	—	25	ns	15.17, 15.39, 15.48, 15.61

Note: When the external addresses monitor function is used, the PLL must be on.

Table 15.9 Bus Timing With PLL Off (CKIO Output) [Mode 2](Conditions: $V_{CC} = 5.0\text{ V} \pm 10\%$, $T_a = -20\text{ to }+75^\circ\text{C}$)

Item	Symbol	Min	Max	Unit	Figures
Address delay time	t_{AD}	3	18	ns	15.16, 15.38, 15.47, 15.60, 15.67, 15.69
\overline{BS} delay time	t_{BSD}	—	21	ns	15.16, 15.38, 15.47, 15.60, 15.67
\overline{CS} delay time 1	t_{CSD1}	—	21	ns	15.16, 15.38, 15.47, 15.60, 15.67
\overline{CS} delay time 3	t_{CSD3}	—	21	ns	15.16, 15.67
Read write delay time	t_{RWD}	3	18	ns	15.16, 15.38, 15.47, 15.60, 15.67
Read strobe delay time 2	t_{RSD2}	—	16	ns	15.16, 15.47, 15.60, 15.67, 15.69
Read data setup time 2	t_{RDS2}	12	—	ns	15.16, 15.38, 15.47, 15.60, 15.67, 15.69
Read data hold time 2	t_{RDH2}	0	—	ns	15.16, 15.67
Read data hold time 3 (SDRAM)	t_{RDH3}	1/2 tcyc	—	ns	15.38
Read data hold time 5 (DRAM)	t_{RDH5}	0	—	ns	15.47
Read data hold time 6 (PSRAM)	t_{RDH6}	0	—	ns	15.60
Read data hold time 7 (interrupt vector)	t_{RDH7}	0	—	ns	15.69
Write enable delay time 2	t_{WED2}	3	18	ns	15.17, 15.61
Write data delay time	t_{WDD}	3	18	ns	15.17, 15.39, 15.48, 15.61
Write data hold time 1	t_{WDH1}	3	—	ns	15.17, 15.39, 15.48, 15.61
Write data hold time 2	t_{WDH2}	5	—	ns	15.17
Write data hold time 3	t_{WDH3}	3	—	ns	15.61
DACK delay time 1	t_{DACD1}	—	18	ns	15.16, 15.38, 15.47, 15.60, 15.67
DACK delay time 3	t_{DACD3}	—	18	ns	15.16, 15.38, 15.47, 15.60, 15.67

Table 15.9 Bus Timing With PLL Off (CKIO Output) [Mode 2] (cont)**(Conditions: $V_{CC} = 5.0\text{ V} \pm 10\%$, $T_a = -20\text{ to }+75^\circ\text{C}$)**

Item	Symbol	Min	Max	Unit	Figures
WAIT setup time	t_{WTS}	22	—	ns	15.19, 15.43, 15.55, 15.67, 15.70
WAIT hold time	t_{WTH}	5	—	ns	15.19, 15.43, 15.55, 15.67, 15.70
$\overline{\text{RAS}}$ delay time 1 (SDRAM)	t_{RASD1}	—	18	ns	15.38
$\overline{\text{RAS}}$ delay time 3 (DRAM)	t_{RASD3}	3	18	ns	15.47
$\overline{\text{CAS}}$ delay time 1 (SDRAM)	t_{CASD1}	—	18	ns	15.38
$\overline{\text{CAS}}$ delay time 3 (DRAM)	t_{CASD3}	3	18	ns	15.47
DQM delay time	t_{DQMD}	—	18	ns	15.38
CKE delay time	t_{CKED}	—	21	ns	15.37
$\overline{\text{CE}}$ delay time 2	t_{CED2}	3	18	ns	15.60
$\overline{\text{OE}}$ delay time 2	t_{OED2}	—	18	ns	15.60
$\overline{\text{IVECF}}$ delay time	t_{IVD}	—	18	ns	15.69
Address input setup time*	t_{ASIN}	14	—	ns	15.71
Address input hold time*	t_{AHIN}	3	—	ns	15.71
$\overline{\text{BS}}$ input setup time*	t_{BSS}	15	—	ns	15.71
$\overline{\text{BS}}$ input hold time*	t_{BSH}	3	—	ns	15.71
Read/write input setup time*	t_{RWS}	15	—	ns	15.71
Read/write input hold time*	t_{RWH}	3	—	ns	15.71
Data buffer on time	t_{DON}	—	18	ns	15.17, 15.39, 15.48, 15.61
Data buffer off time	t_{DOF}	—	18	ns	15.17, 15.39, 15.48, 15.61
Address hold time 2	t_{AH2}	5	—	ns	15.17

Note: When the external addresses monitor function is used, the PLL must be on.

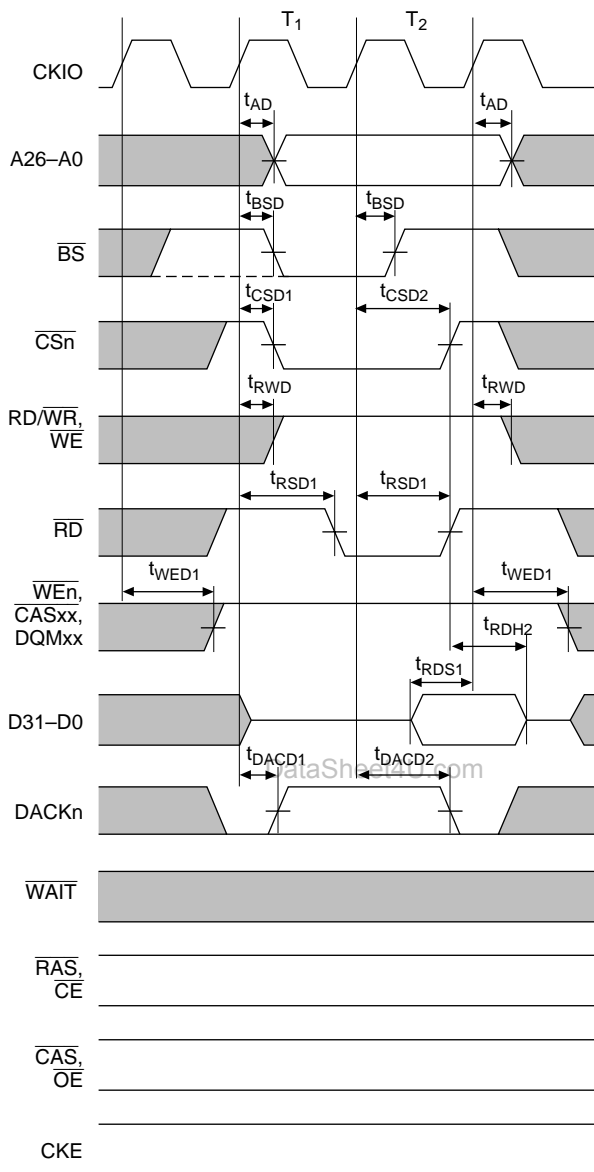

- Notes:
1. The dotted line shows the waveform when synchronous DRAM is connected.
 2. t_{RDH2} is specified from the rise of \overline{CSn} or \overline{RD} , whichever is first.
 3. The $DACKn$ waveform shown is for the case where active-high has been specified.

Figure 15.14 Basic Read Cycle (No Waits, PLL On)

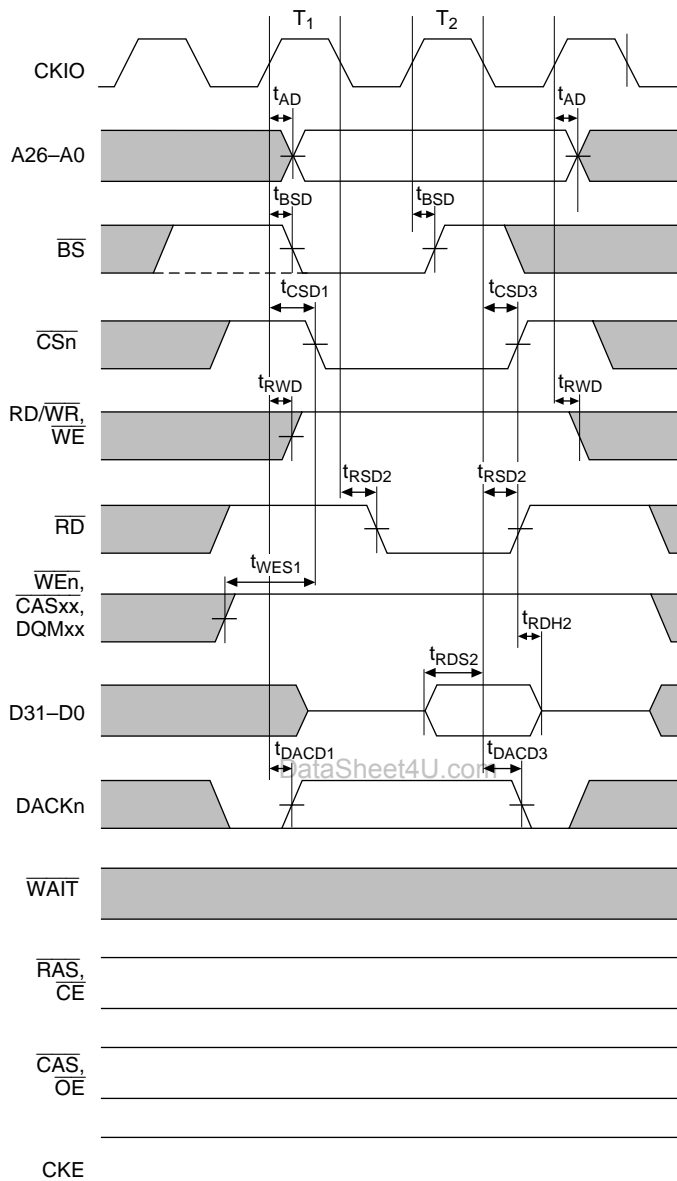

- Notes:
1. The dotted line shows the waveform when synchronous DRAM is connected.
 2. t_{RDH2} is specified from the rise of \overline{CSn} or \overline{RD} , whichever is first.
 3. The \overline{DACKn} waveform shown is for the case where active-high has been specified.

Figure 15.16 Basic Read Cycle (No Waits, PLL Off)

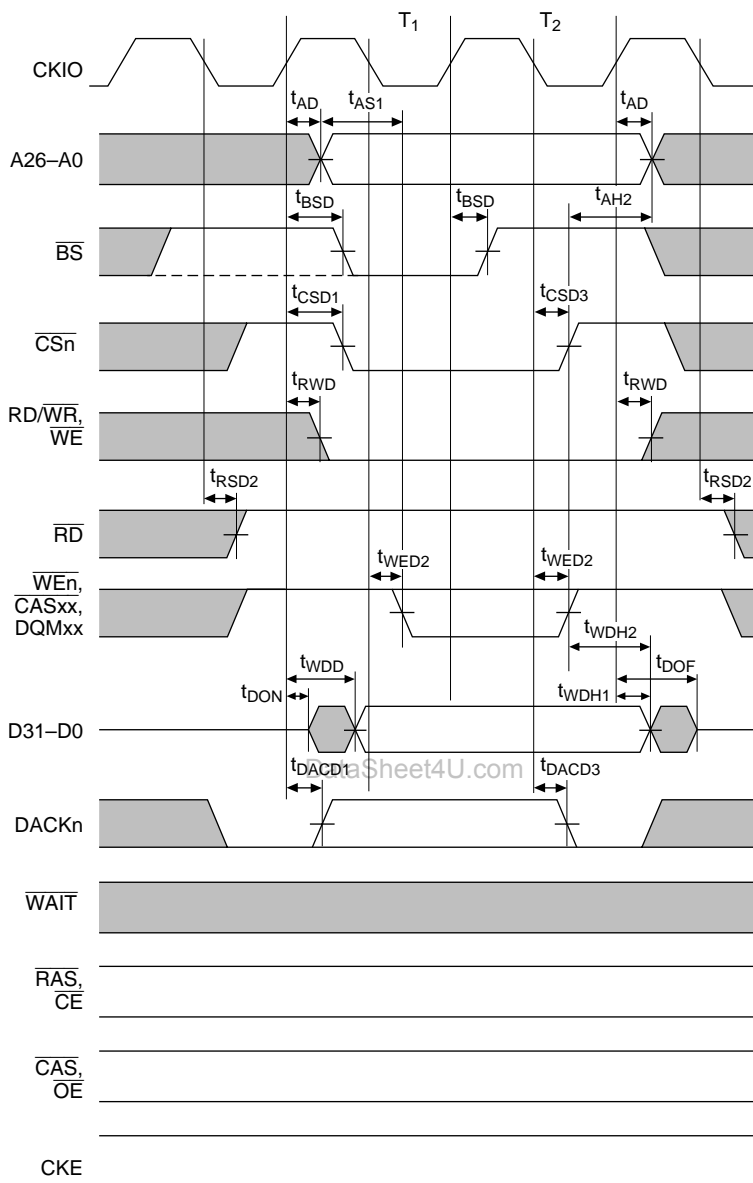

- Notes: 1. The dotted line shows the waveform when synchronous DRAM is connected.
 2. The DACKn waveform shown is for the case where active-high has been specified.

Figure 15.17 Basic Write Cycle (No Waits, PLL Off)

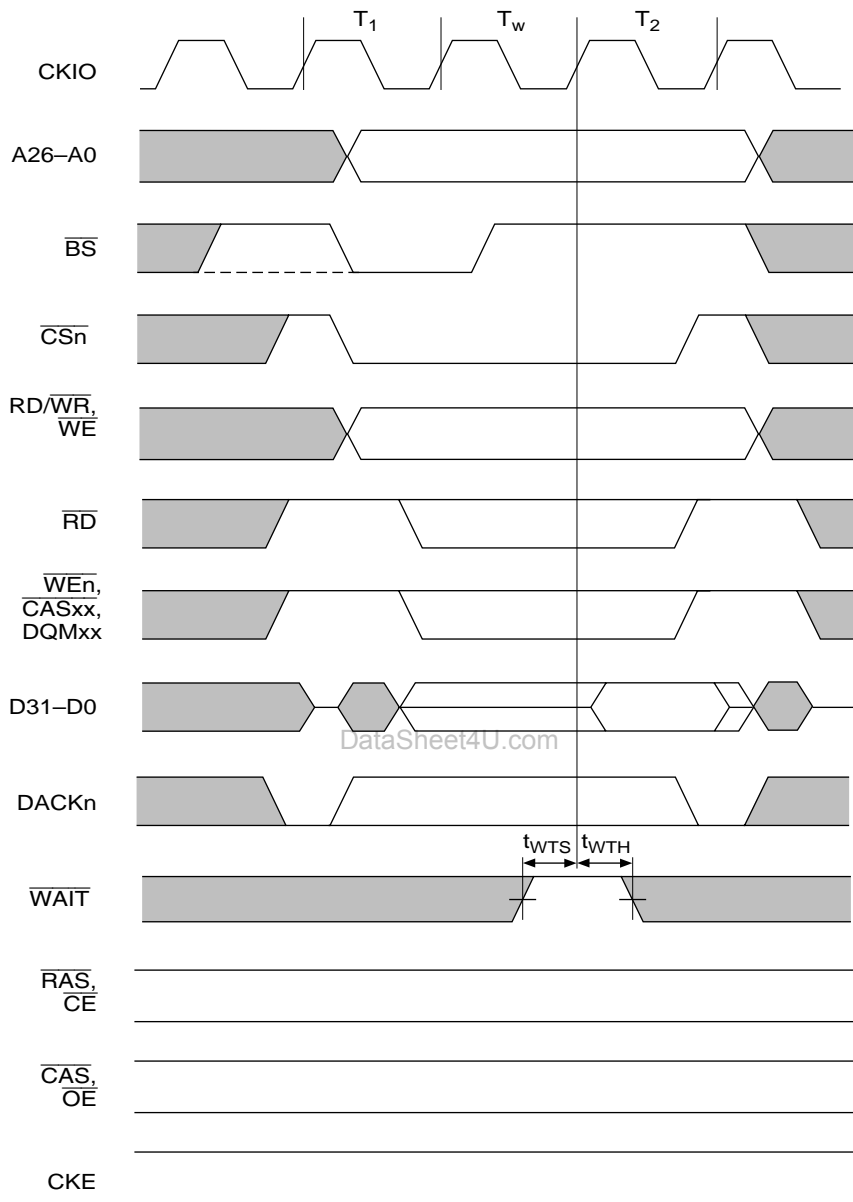

- Notes: 1. The dotted line shows the waveform when synchronous DRAM is connected.
 2. The DACKn waveform shown is for the case where active-high has been specified.

Figure 15.18 Basic Bus Cycle (1 Wait Cycle)

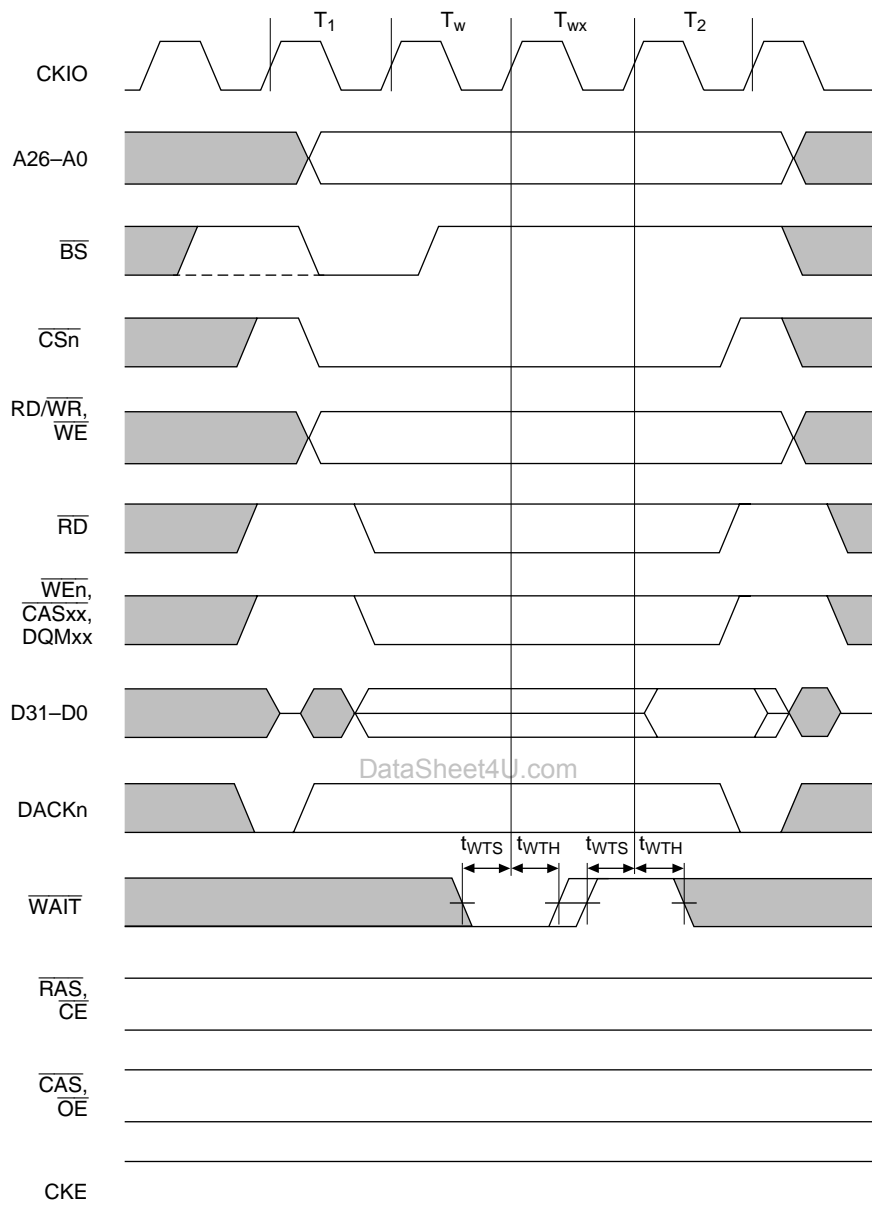

- Notes: 1. The dotted line shows the waveform when synchronous DRAM is connected.
 2. The DACKn waveform shown is for the case where active-high has been specified.

Figure 15.19 Basic Bus Cycle (External Wait Input)

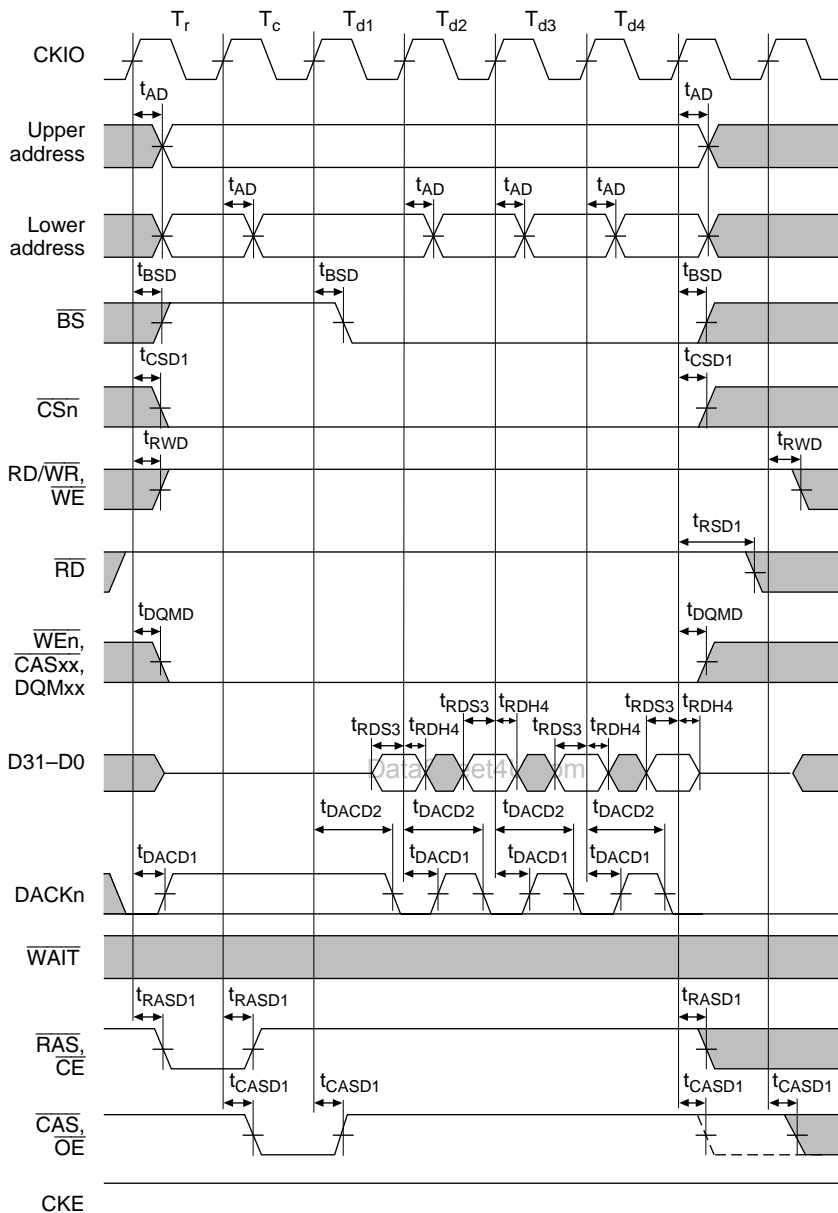

- Notes: 1. The dotted line shows the waveform when synchronous DRAM in another CS space is accessed.
 2. The DACKn waveform shown is for the case where active-high has been specified.

Figure 15.20 Synchronous DRAM Read Bus Cycle
 (RCD = 1 Cycle, CAS Latency = 1 Cycle, Bursts = 4, PLL On)

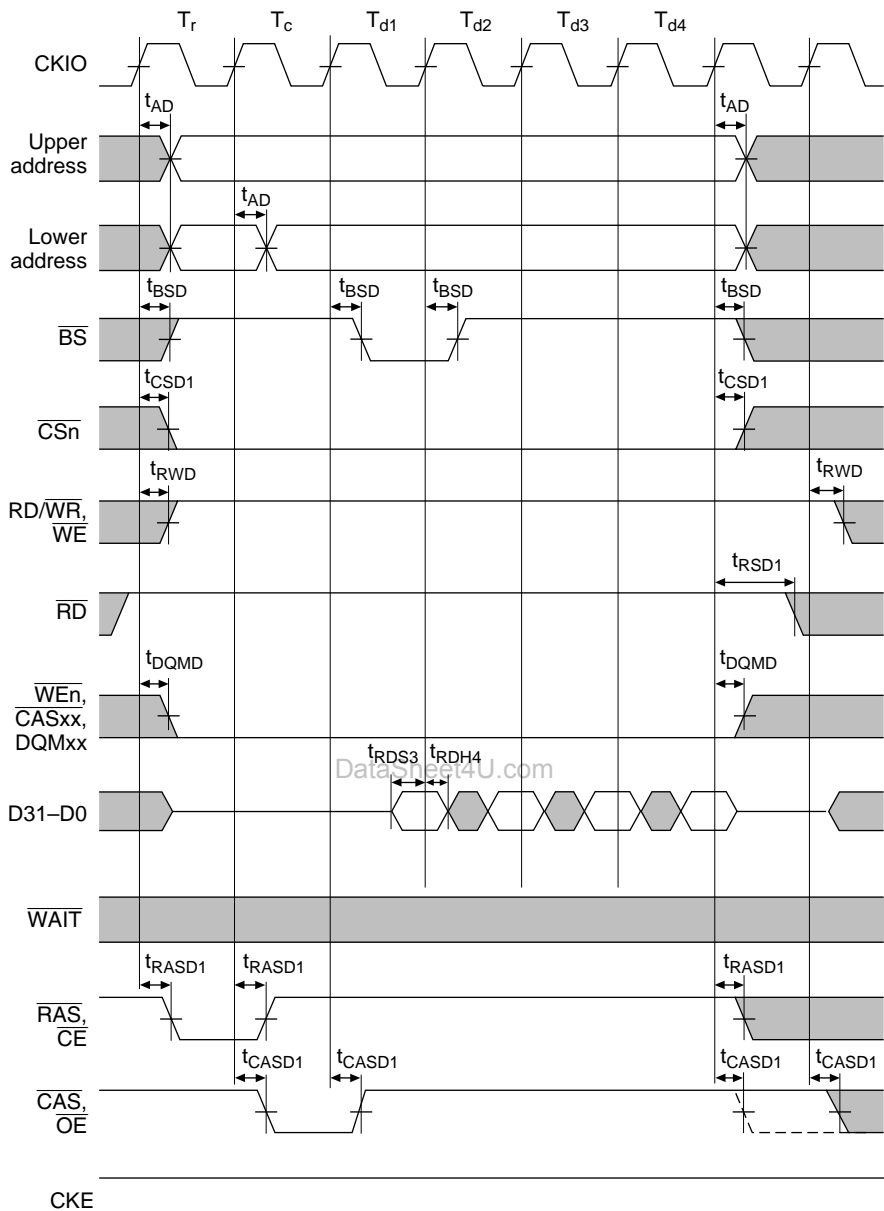

Note: The dotted line shows the waveform when synchronous DRAM in another CS space is accessed.

Figure 15.21 Synchronous DRAM Single Read Bus Cycle
(RCD = 1 Cycle, CAS Latency = 1 Cycle, Bursts = 4, PLL On)

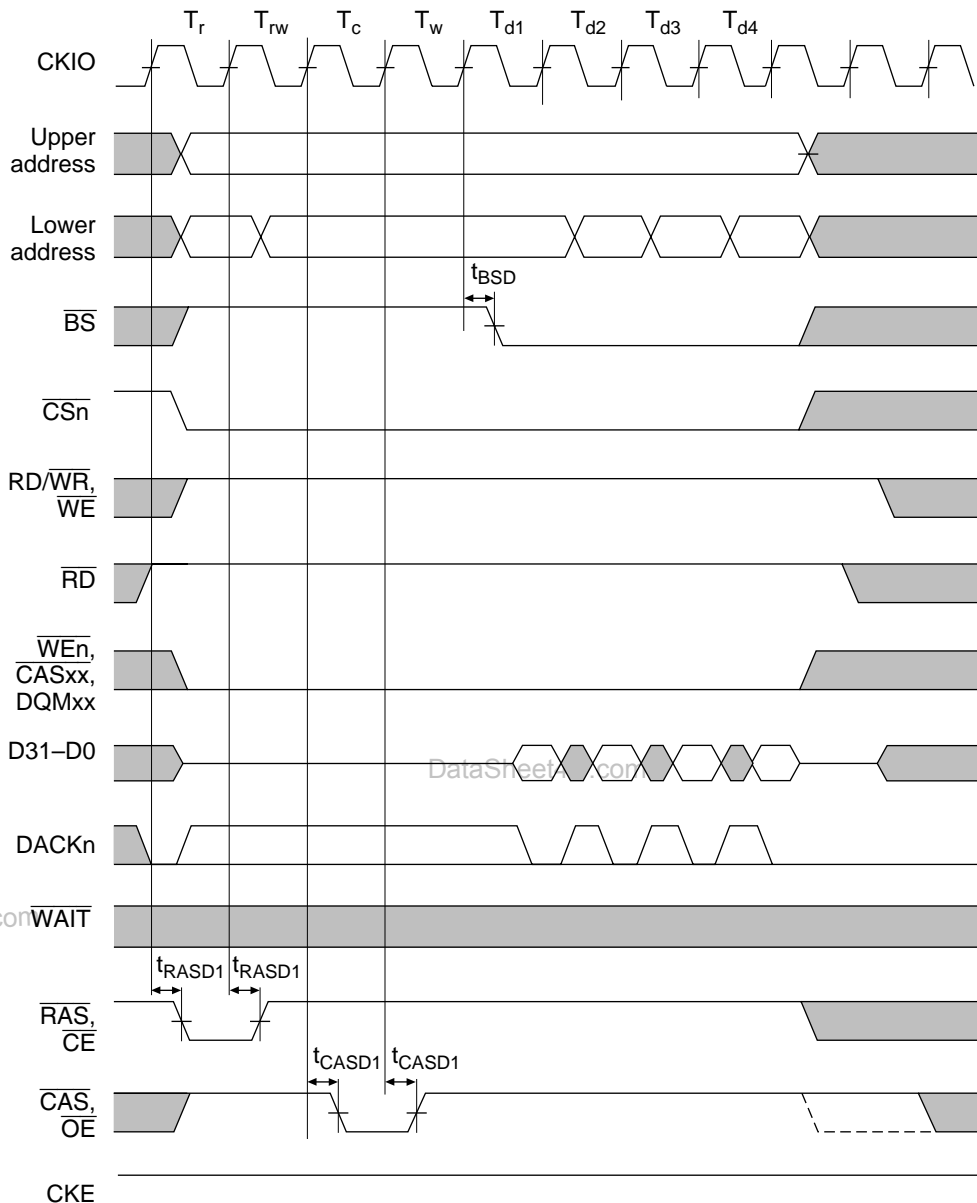

- Notes: 1. The dotted line shows the waveform when synchronous DRAM in another CS space is accessed.
 2. The DACKn waveform shown is for the case where active-high has been specified.

Figure 15.22 Synchronous DRAM Read Bus Cycle
(RCD = 2 Cycles, CAS Latency = 2 Cycles, Bursts = 4)

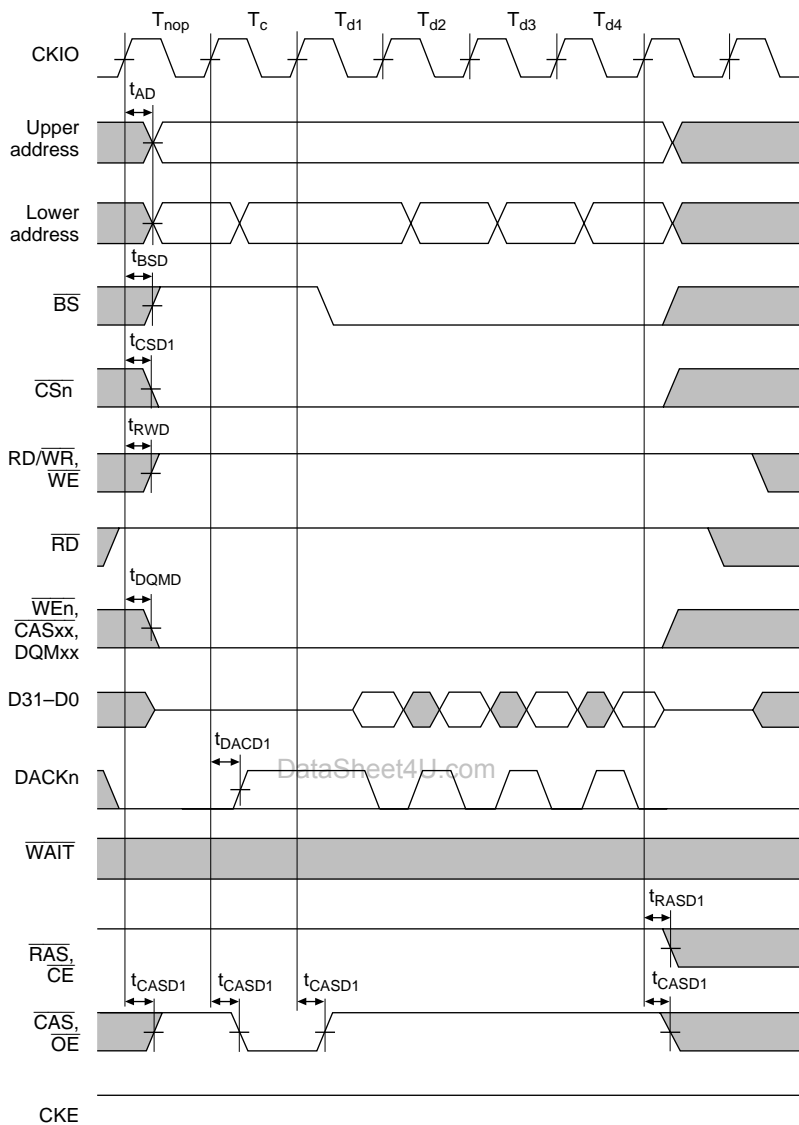

Note: The DACKn waveform shown is for the case where active-high has been specified.

**Figure 15.23 Synchronous DRAM Read Bus Cycle
(Bank Active, Same Row Access, CAS Latency = 1 Cycle)**

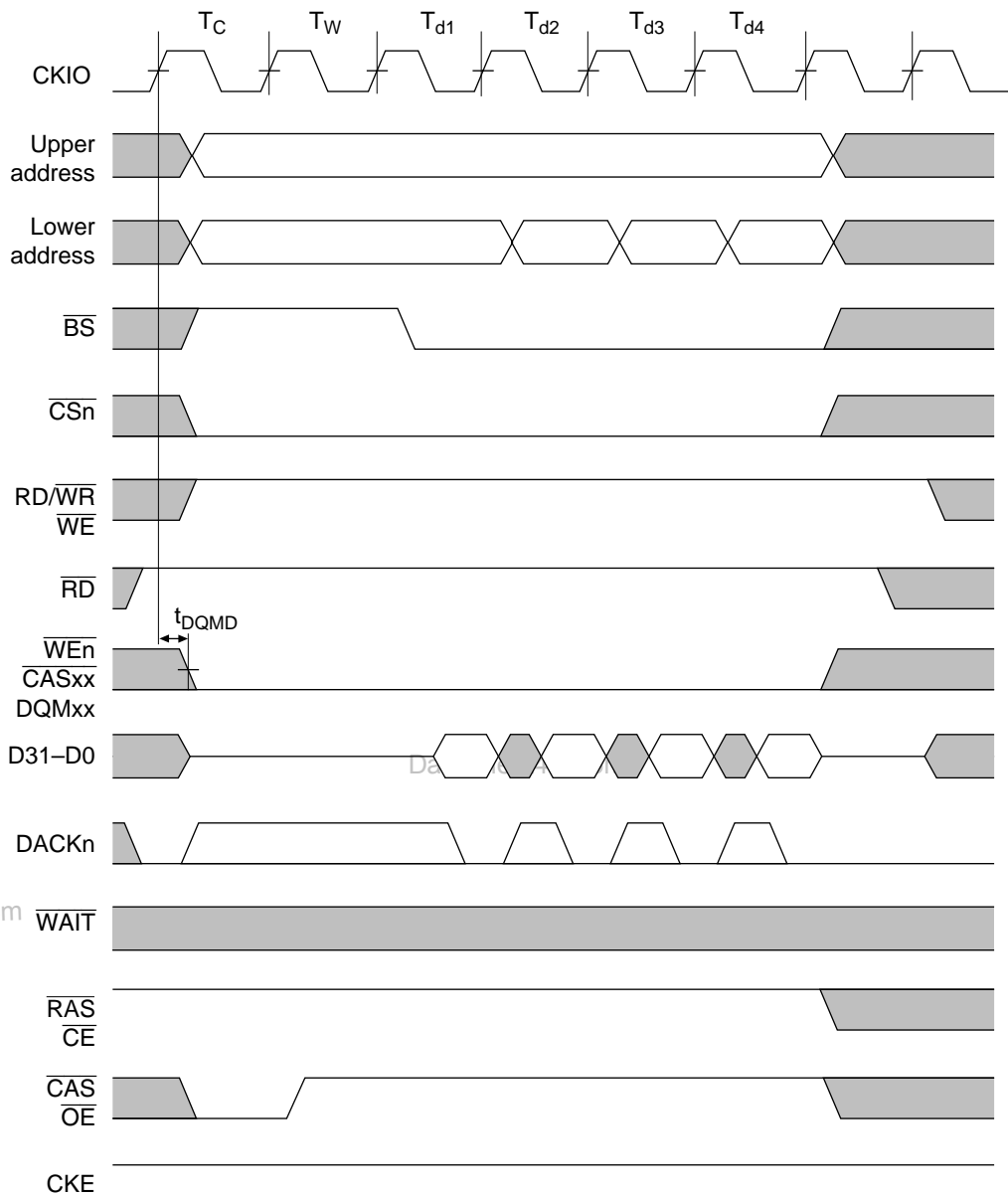

Note: The DACKn waveform shown is for the case where active-high has been specified.

**Figure 15.24 Synchronous DRAM Read Bus Cycle
(Bank Active, Same Row Access, CAS Latency = 2 Cycles)**

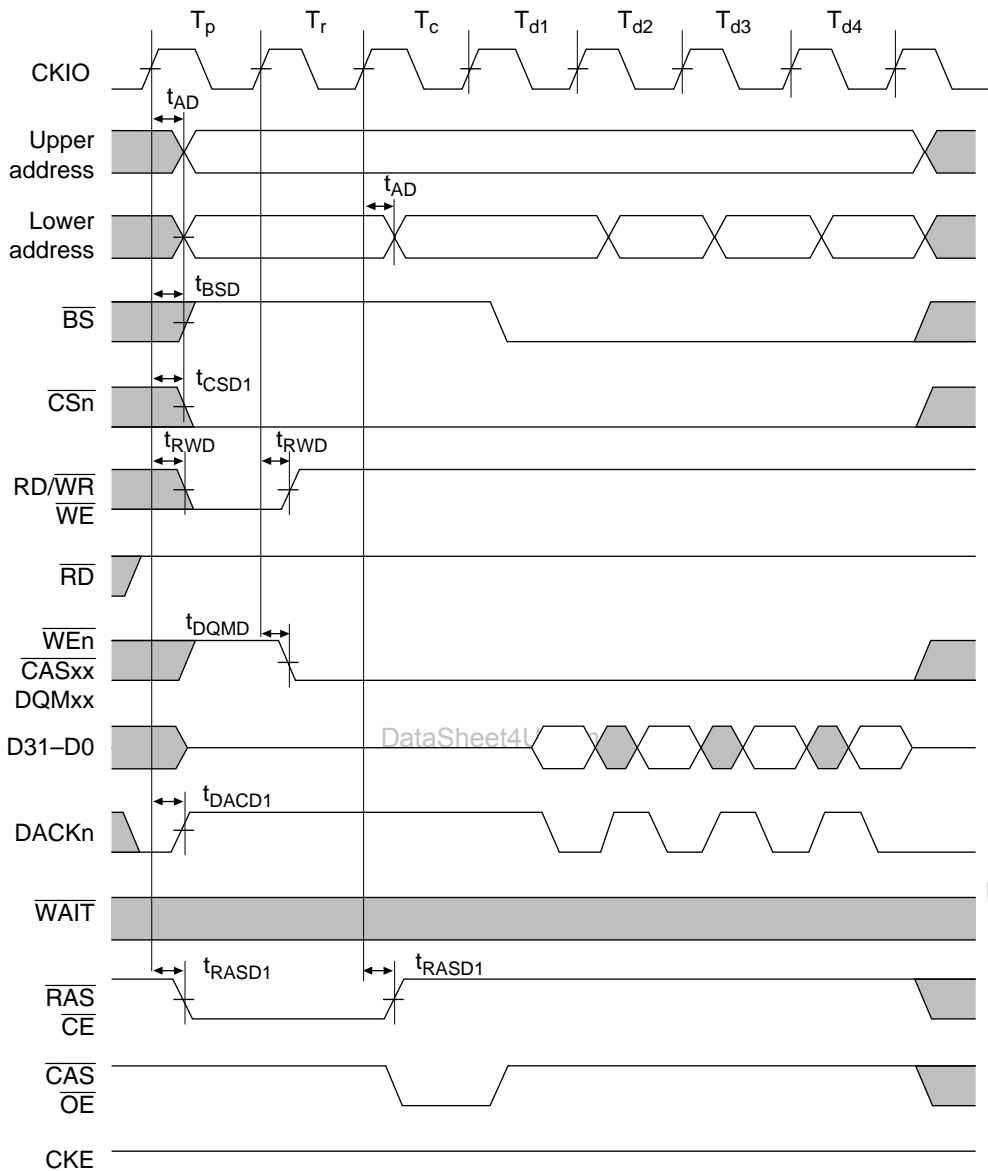

Note: The DACKn waveform shown is for the case where active-high has been specified.

Figure 15.25 Synchronous DRAM Read Bus Cycle (Bank Active, Different Row Access, TRP = 1 Cycle, RCD = 1 Cycle, CAS Latency = 1 Cycle)

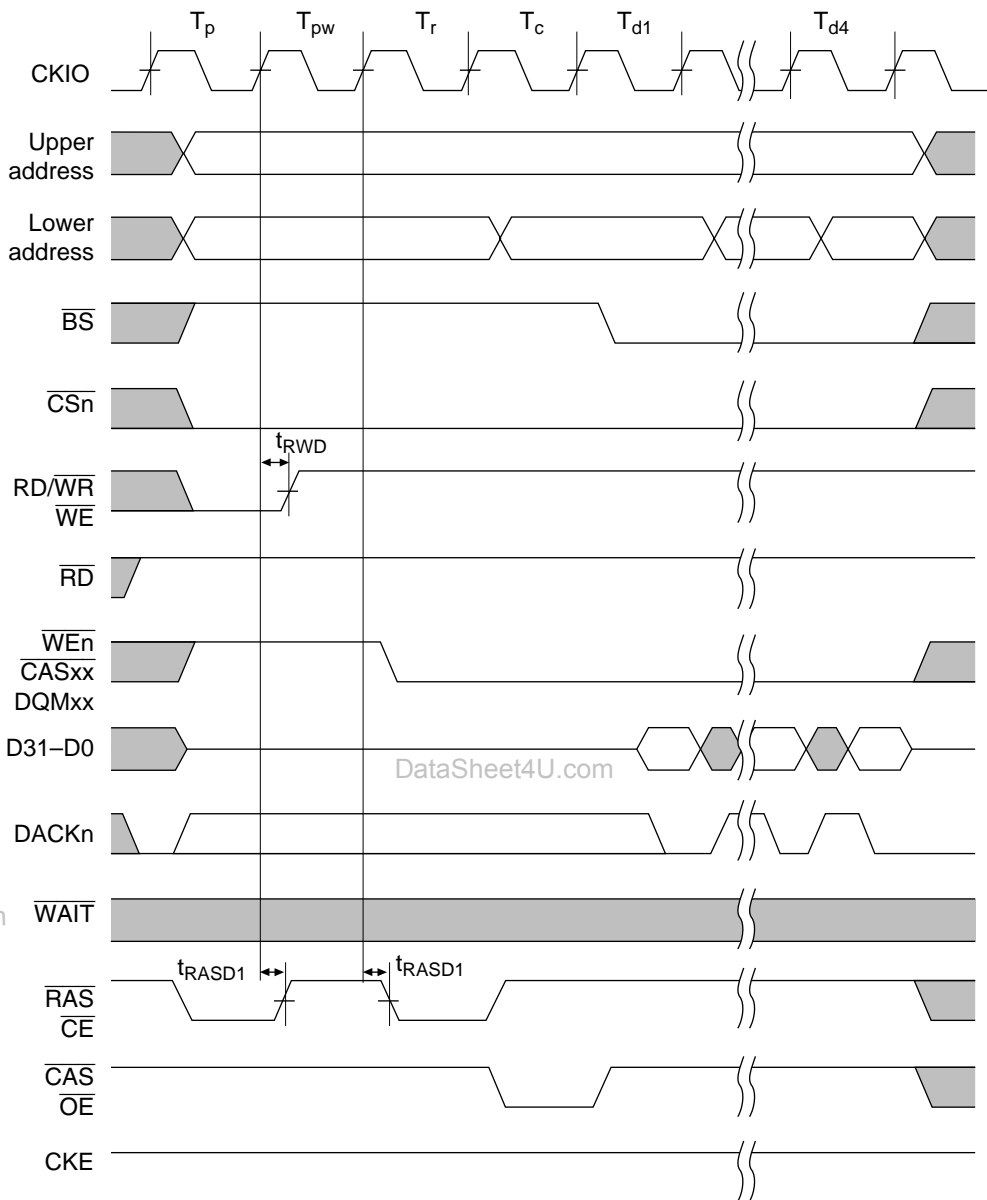

Note: The DACKn waveform shown is for the case where active-high has been specified.

Figure 15.26 Synchronous DRAM Read Bus Cycle (Bank Active, Different Row Access, TRP = 2 Cycles, RCD = 1 Cycle, CAS Latency = 1 Cycle)

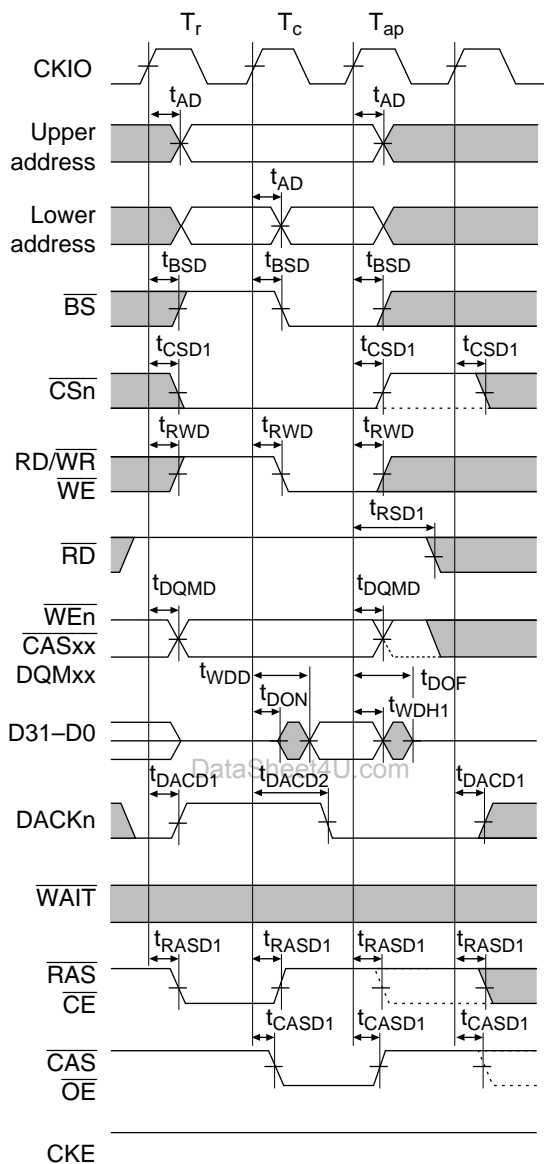

- Notes: 1. Dotted lines show the waveforms when synchronous DRAM in another CS space is accessed.
 2. The DACKn waveform shown is for the case where active-high has been specified.

Figure 15.27 Synchronous DRAM Write Bus Cycle
 (RCD = 1 Cycle, TRWL = 1 Cycle, PLL On)

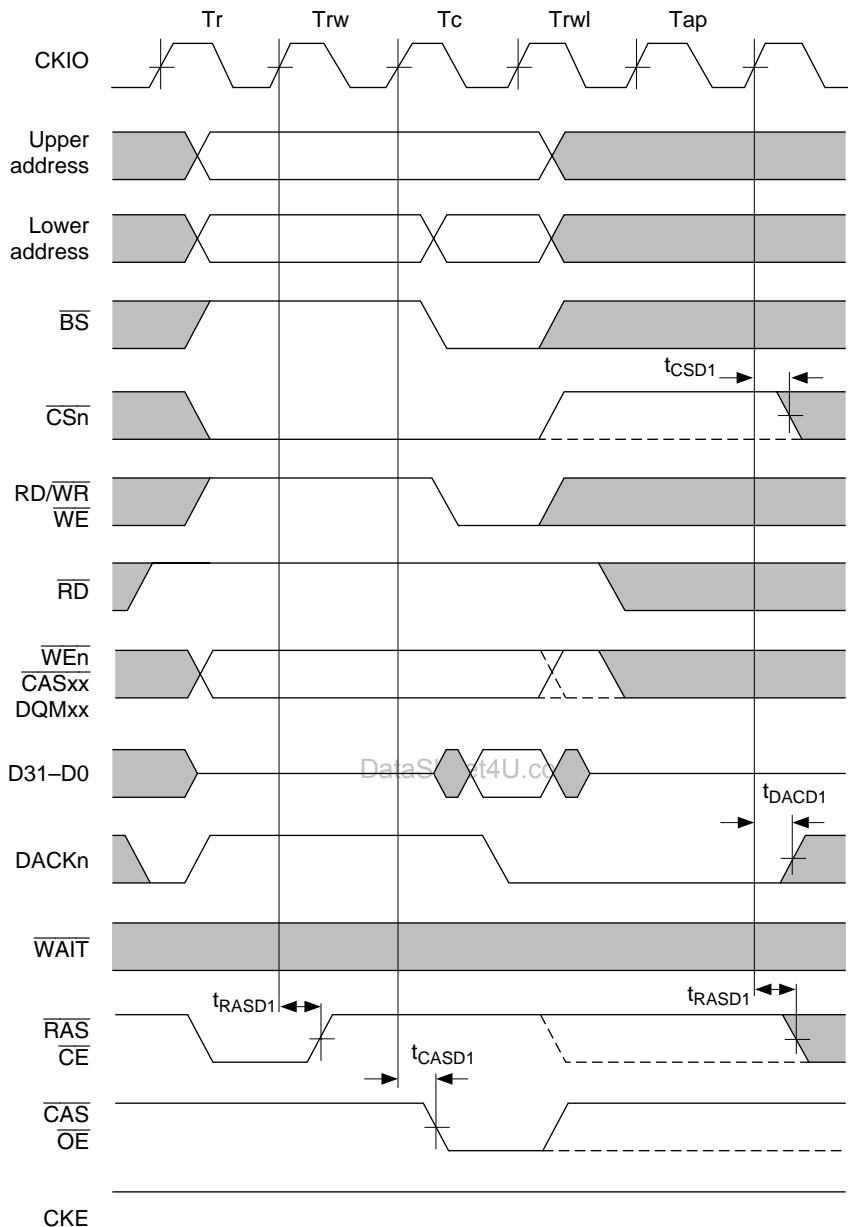

- Notes:
1. Dotted lines show the waveforms when synchronous DRAM in another CS space is accessed.
 2. The DACK_n waveform shown is for the case where active-high has been specified.

Figure 15.28 Synchronous DRAM Write Bus Cycle
(RCD = 2 Cycles, TRWL = 2 Cycles)

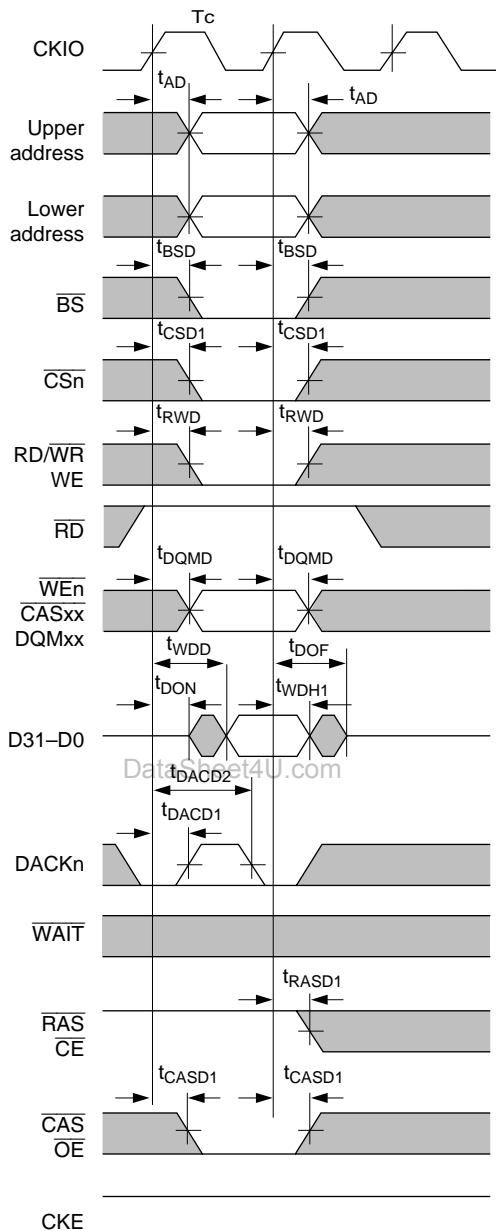

Note: The DACKn waveform shown is for the case where active-high has been specified.

Figure 15.29 Synchronous DRAM Write Bus Cycle (Bank Active, Same Row Access)

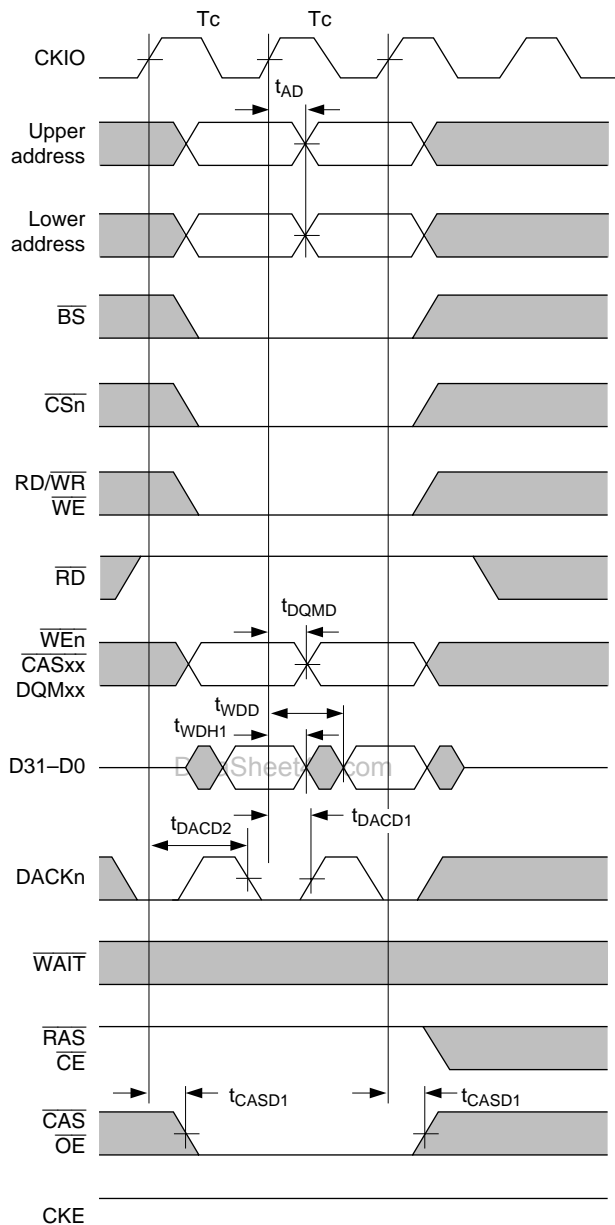

Note: The DACKn waveform shown is for the case where active-high has been specified.

Figure 15.30 Synchronous DRAM Consecutive Write Cycles (Bank Active, Same Row Access)

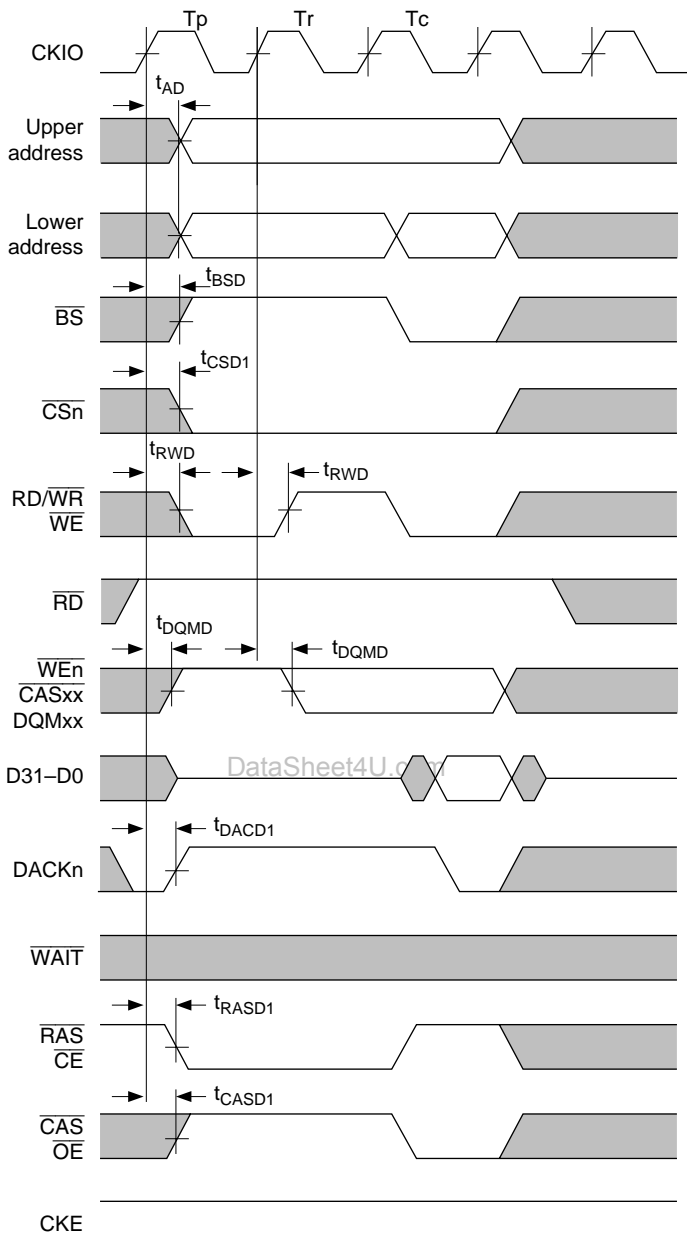

Note: The DACKn waveform shown is for the case where active-high has been specified.

**Figure 15.31 Synchronous DRAM Write Bus Cycle
(Bank Active, Different Row Access, TRP = 1 Cycle, RCD = 1 Cycle)**

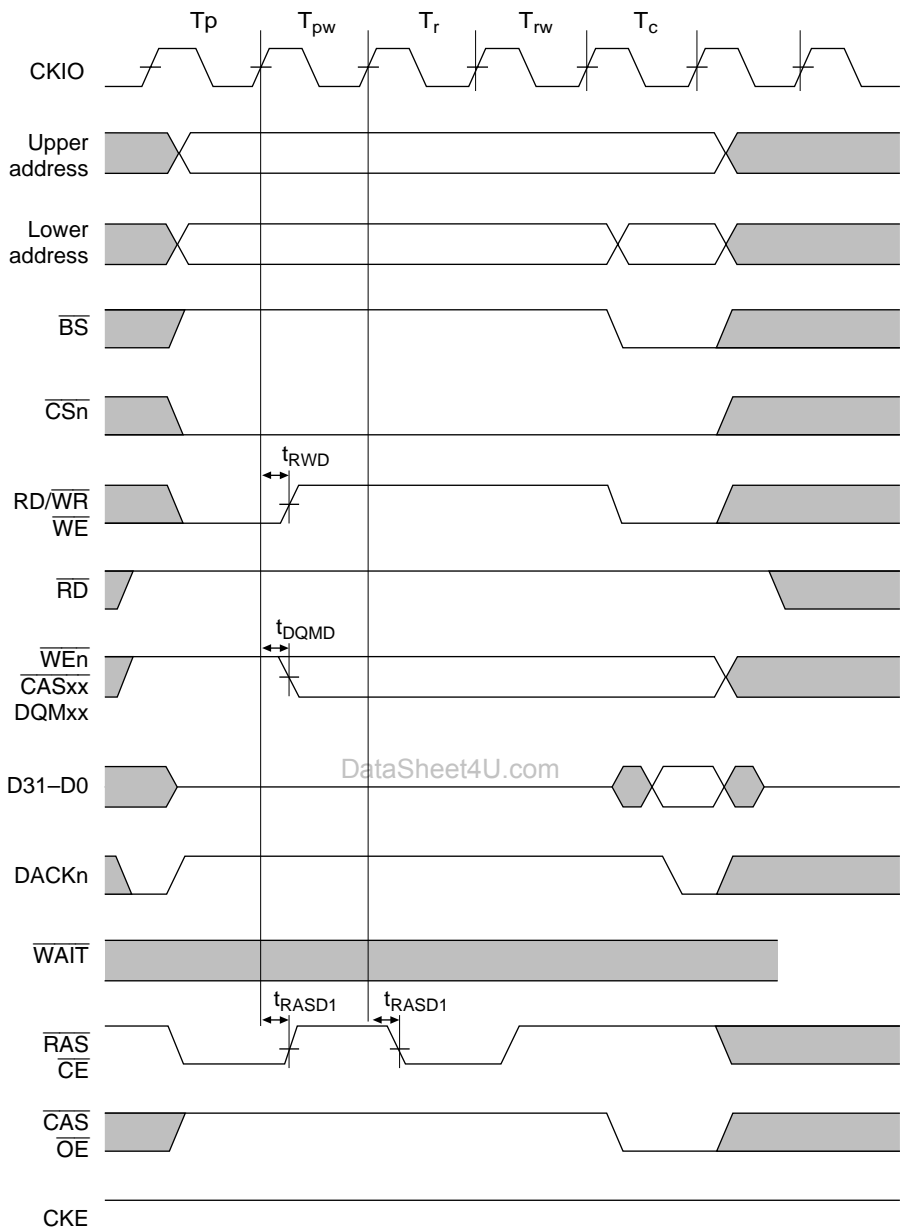

Note: The DACKn waveform shown is for the case where active-high has been specified.

Figure 15.32 Synchronous DRAM Write Bus Cycle
(Bank Active, Different Row Access, TRP = 2 Cycles, RCD = 2 Cycles)

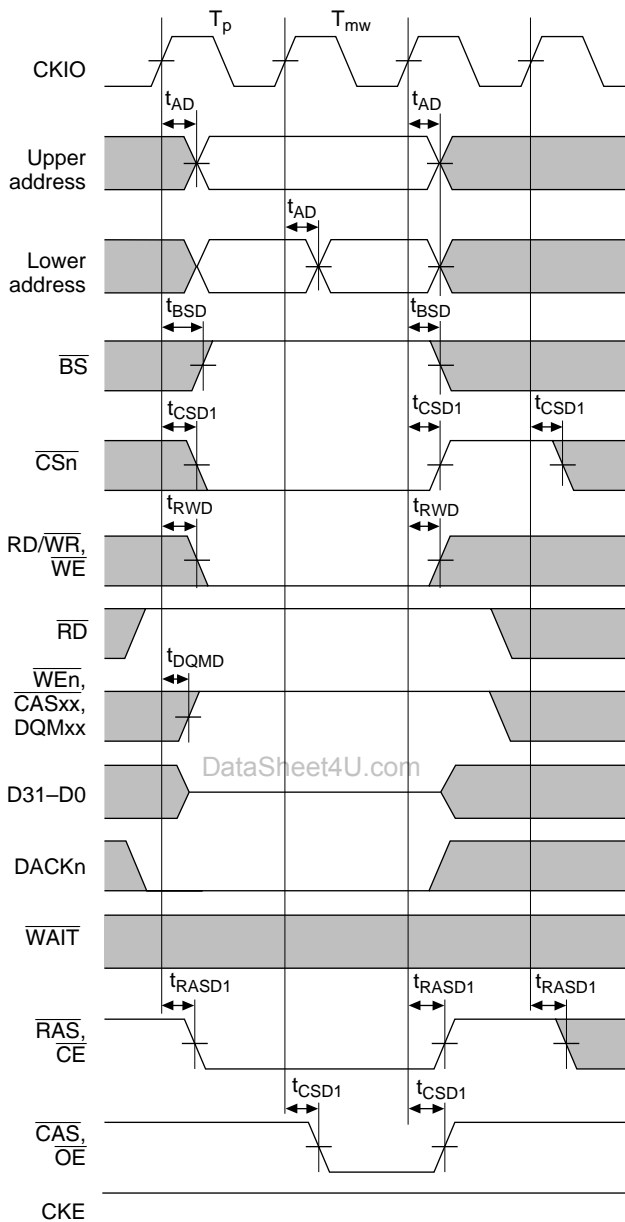

Figure 15.33 Synchronous DRAM Mode Register Write Cycle (TRP = 1 Cycle)

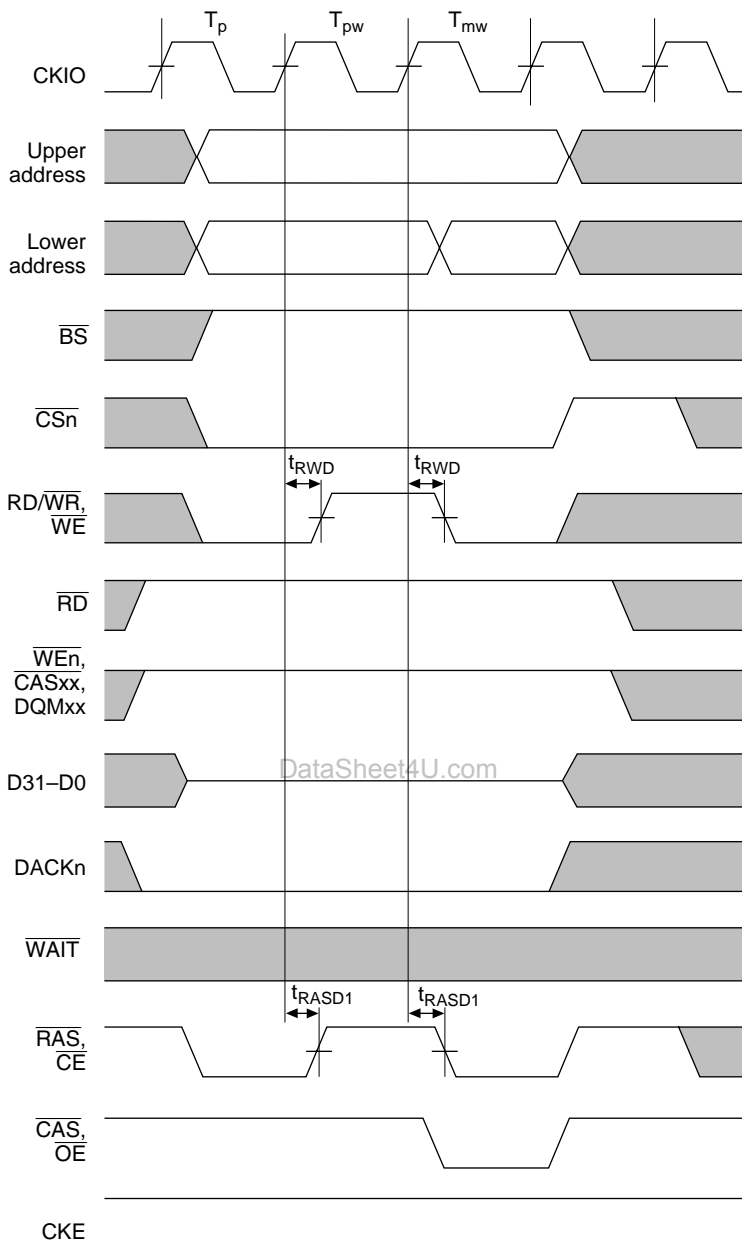
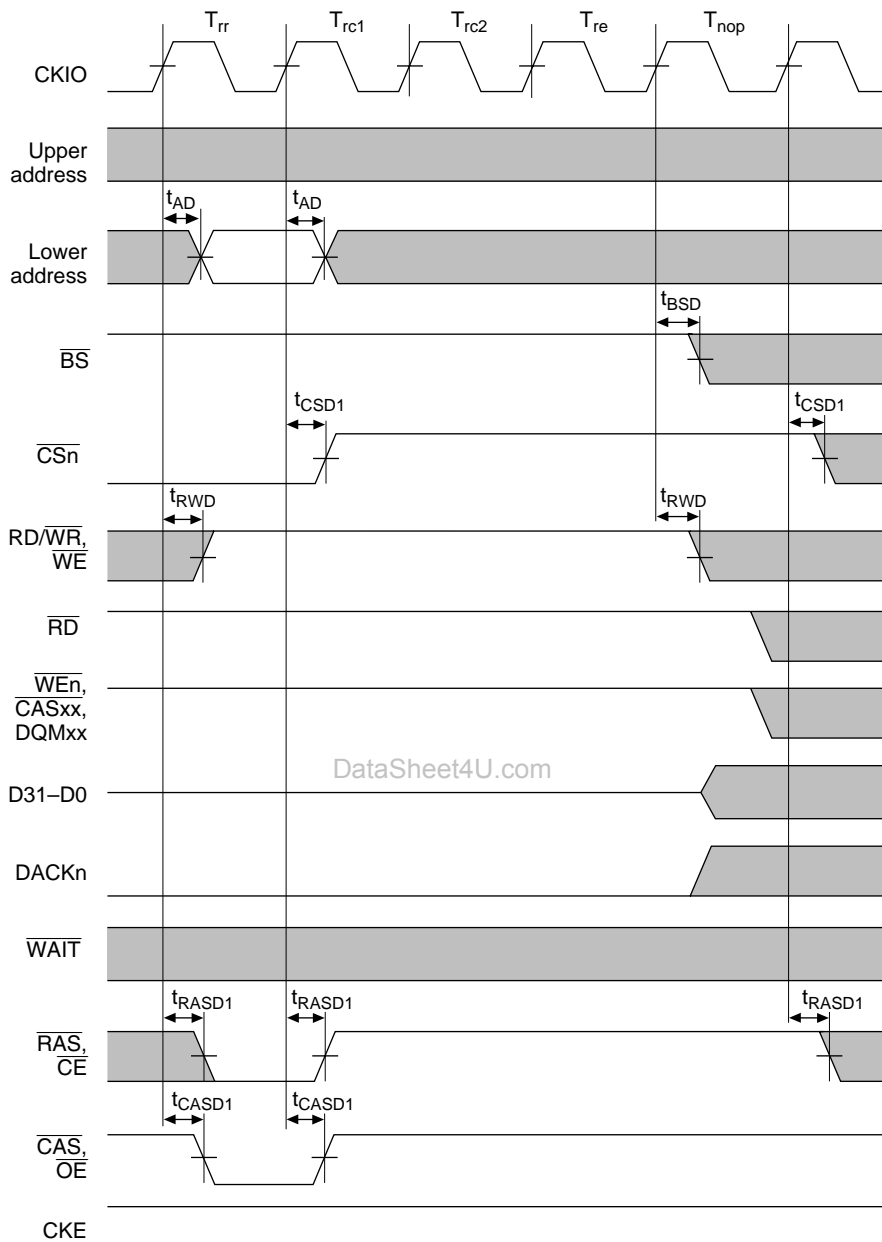

Figure 15.34 Synchronous DRAM Mode Register Write Cycle (TRP = 2 Cycles)



Note: A precharge cycle always precedes the auto-refresh cycle by the number of cycles specified by TRP.

Figure 15.35 Synchronous DRAM Auto-Refresh Cycle ($TRAS = 2$ Cycles)

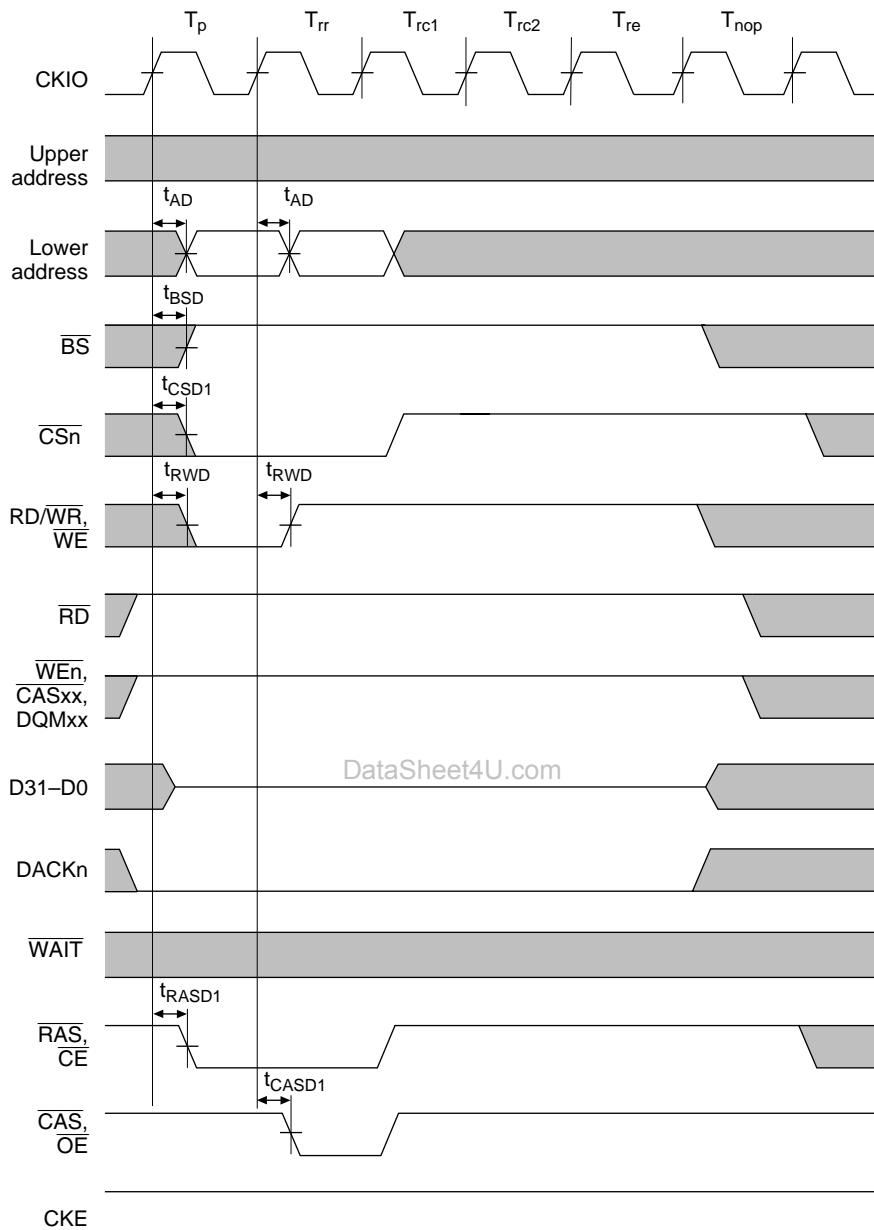
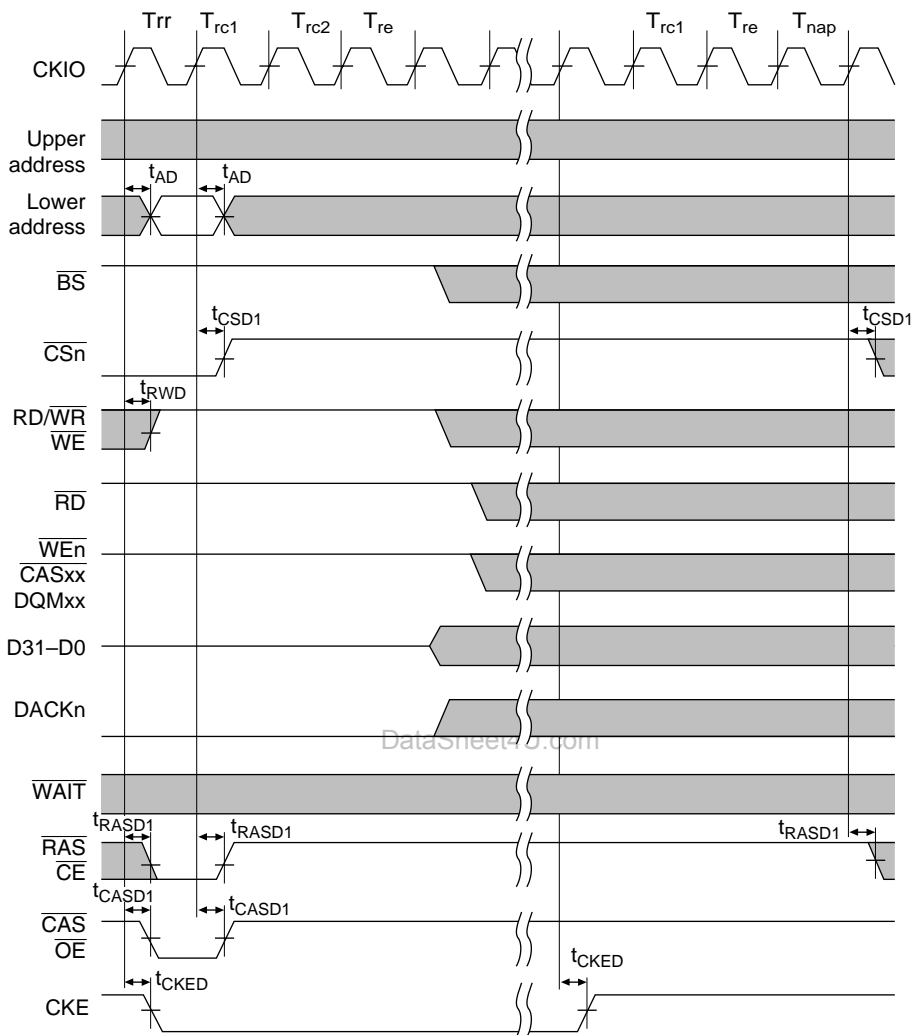
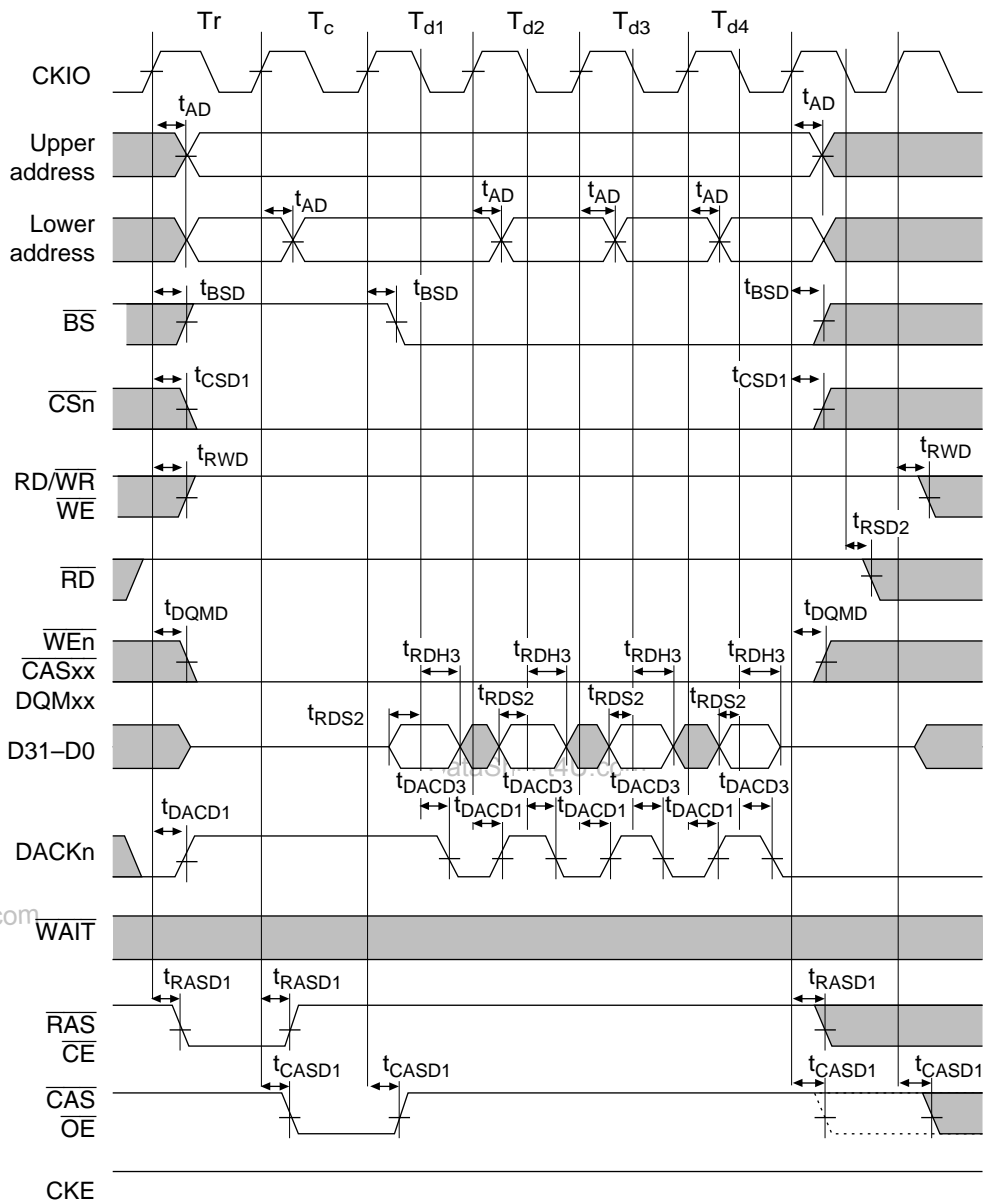

Figure 15.36 Synchronous DRAM Auto-Refresh Cycle
 (Shown From Precharge Cycle, $TRP = 1$ Cycle, $TRAS = 2$ Cycles)



Note: A precharge cycle always precedes the self-refresh cycle by the number of cycles specified by TRP.

Figure 15.37 Synchronous DRAM Self-Refresh Cycle ($TRAS = 2$)



- Notes: 1. The dotted line shows the waveform when synchronous DRAM in another CS space is accessed.
 2. The DACKn waveform shown is for the case where active-high has been specified.

Figure 15.38 Synchronous DRAM Read Bus Cycle

(RCD = 1 Cycle, CAS Latency = 1 Cycle, TRP = 1 Cycle, Bursts = 4, PLL Off)

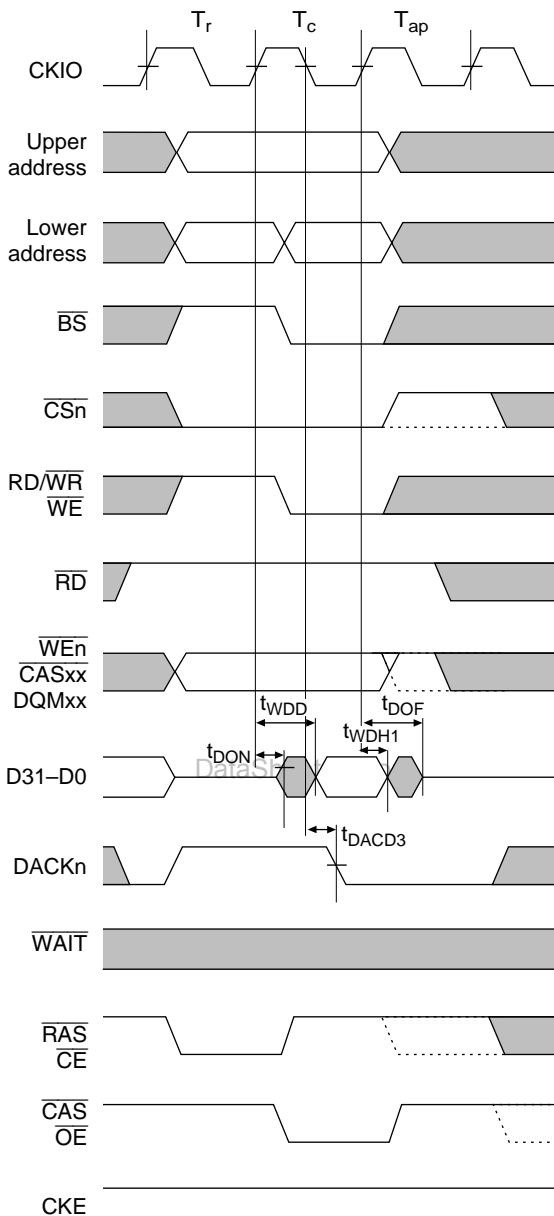

- Notes:
1. Dotted lines show the waveforms when synchronous DRAM in another CS space is accessed.
 2. The DACKn waveform shown is for the case where active-high has been specified.

Figure 15.39 Synchronous DRAM Write Bus Cycle
(RCD = 1 Cycle, TRWL = 1 Cycle, PLL Off)

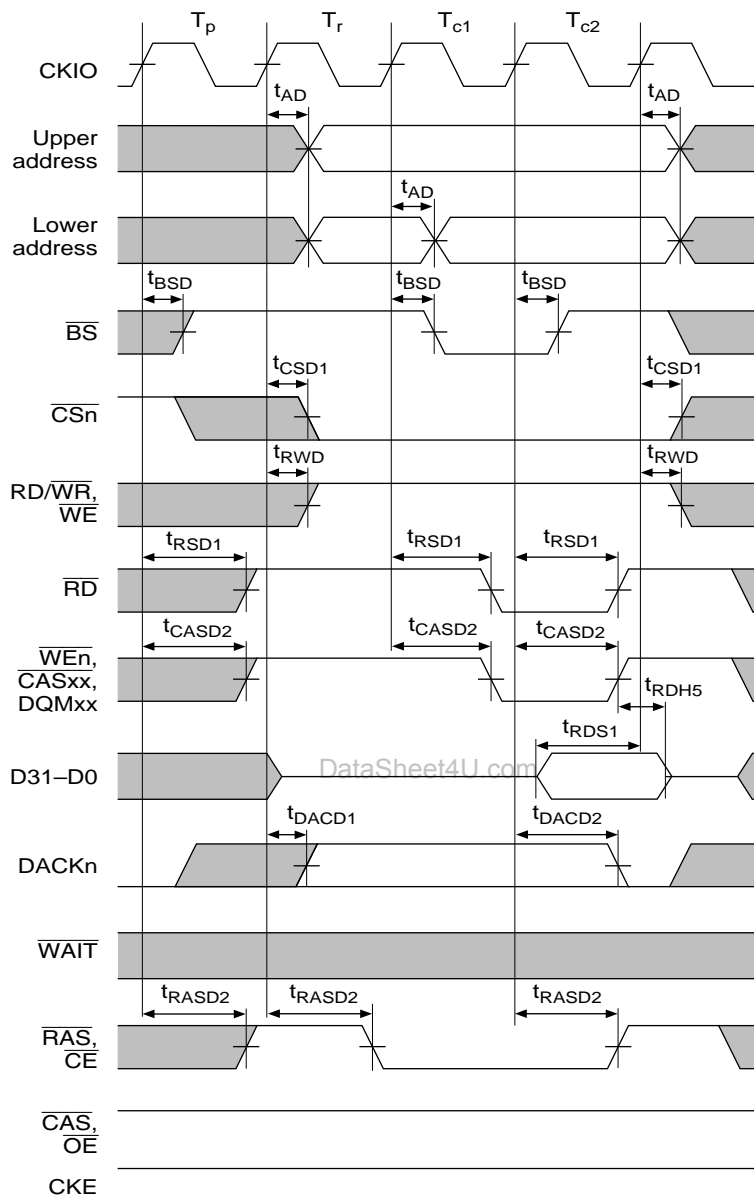

- Notes: 1. t_{RDH5} is specified from the rise of \overline{RD} or \overline{CASxx} , whichever is first.
 2. The $DACKn$ waveform shown is for the case where active-high has been specified.

Figure 15.40 DRAM Read Cycle (TRP = 1 Cycle, RCD = 1 Cycle, No Waits, PLL On)

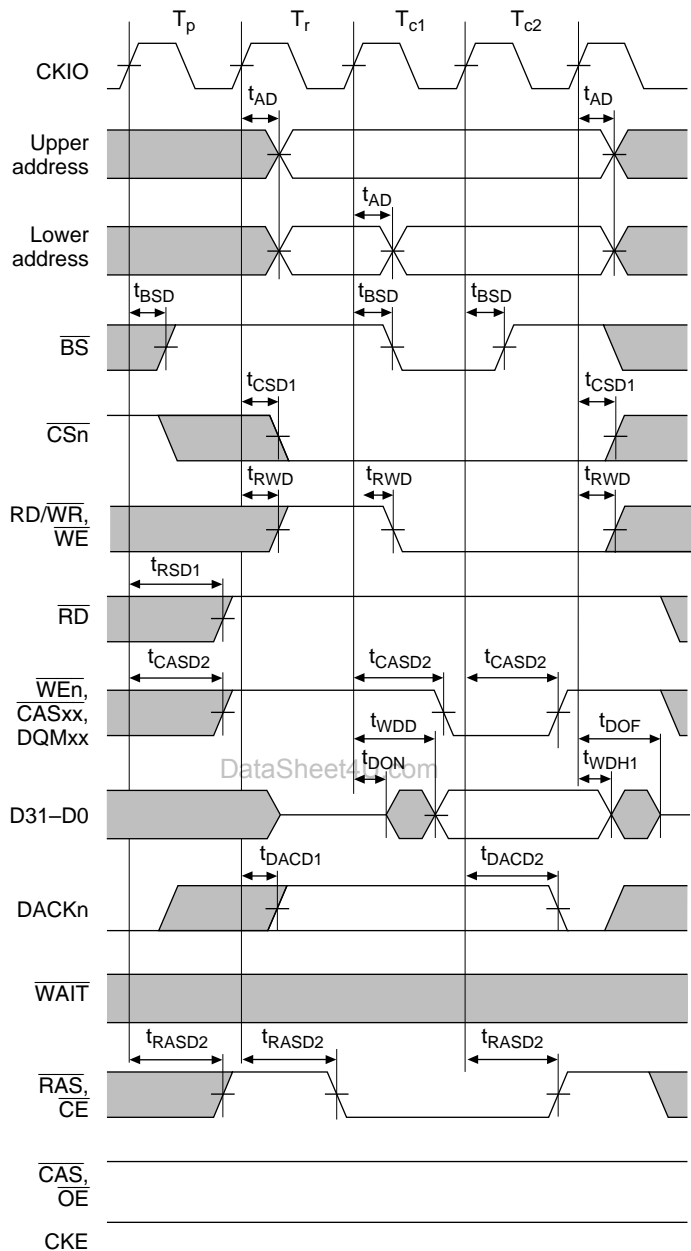

Note: The $DACK_n$ waveform shown is for the case where active-high has been specified.

Figure 15.41 DRAM Write Cycle
(TRP = 1 Cycle, RCD = 1 Cycle, No Waits, PLL On)

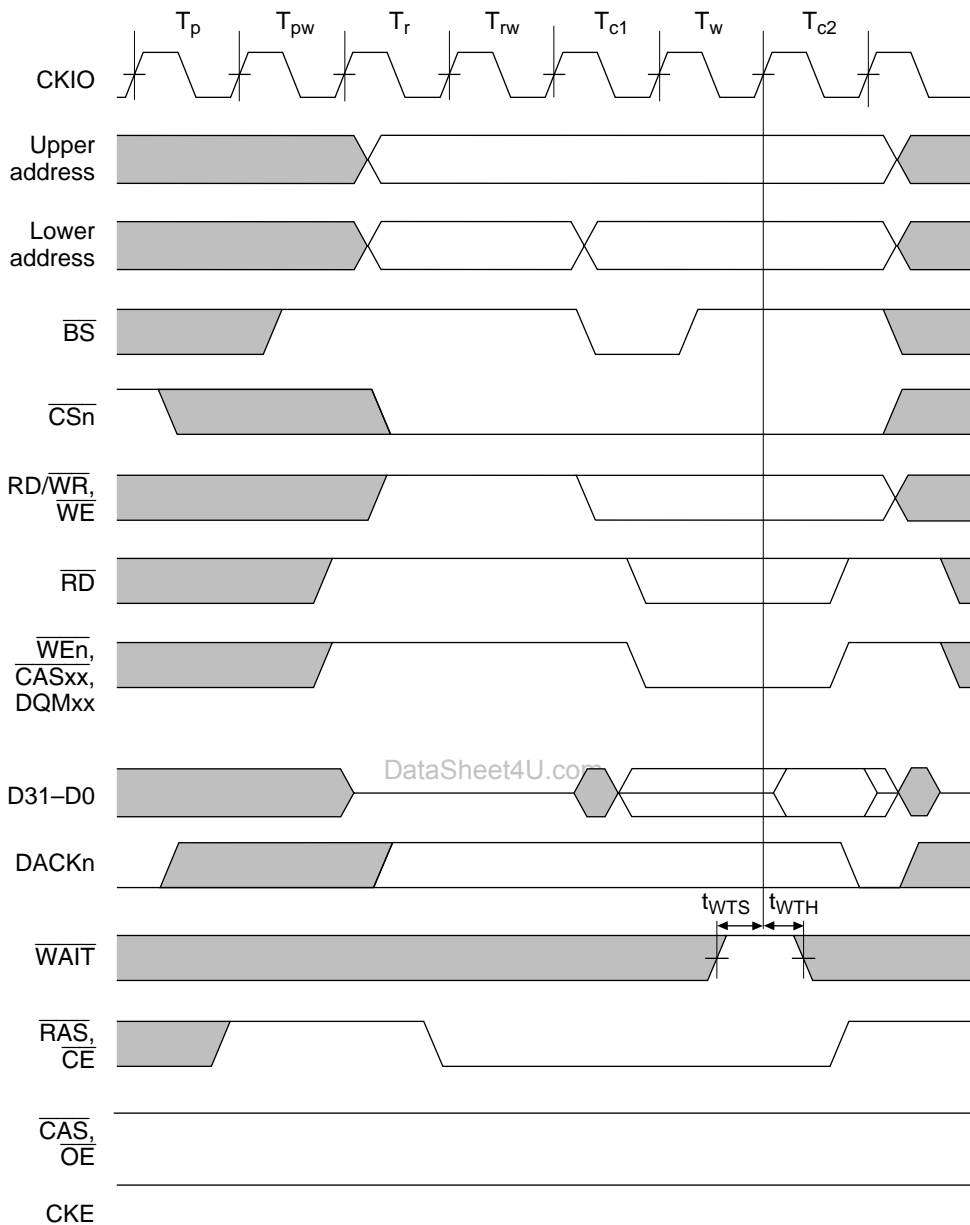

Note: The DACKn waveform shown is for the case where active-high has been specified.

Figure 15.42 DRAM Bus Cycle (TRP = 2 Cycles, RCD = 2 Cycles, 1 Wait)

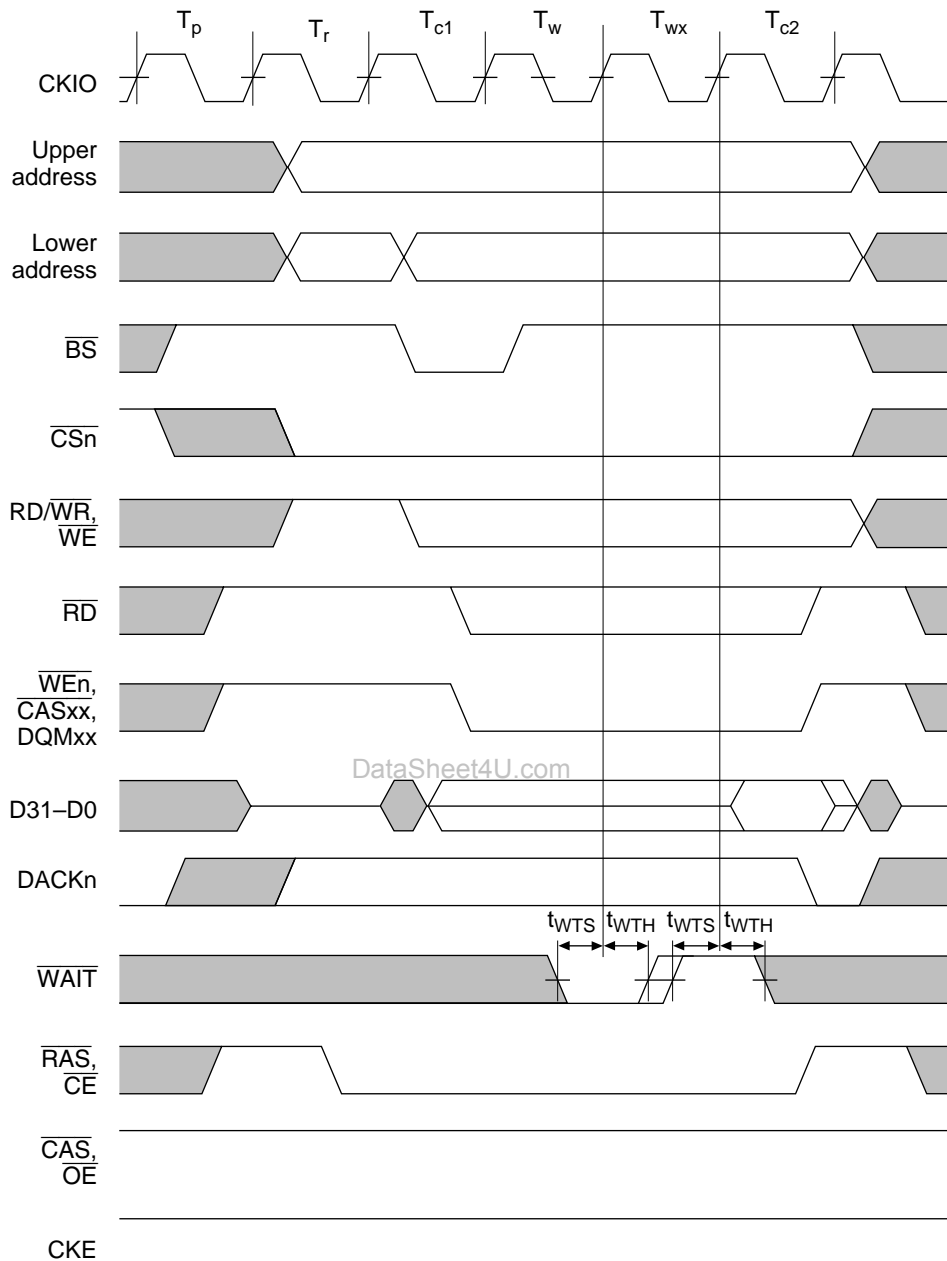

Note: The DACKn waveform shown is for the case where active-high has been specified.

Figure 15.43 DRAM Bus Cycle (TRP = 1 Cycle, RCD = 1 Cycle, External Wait Input)

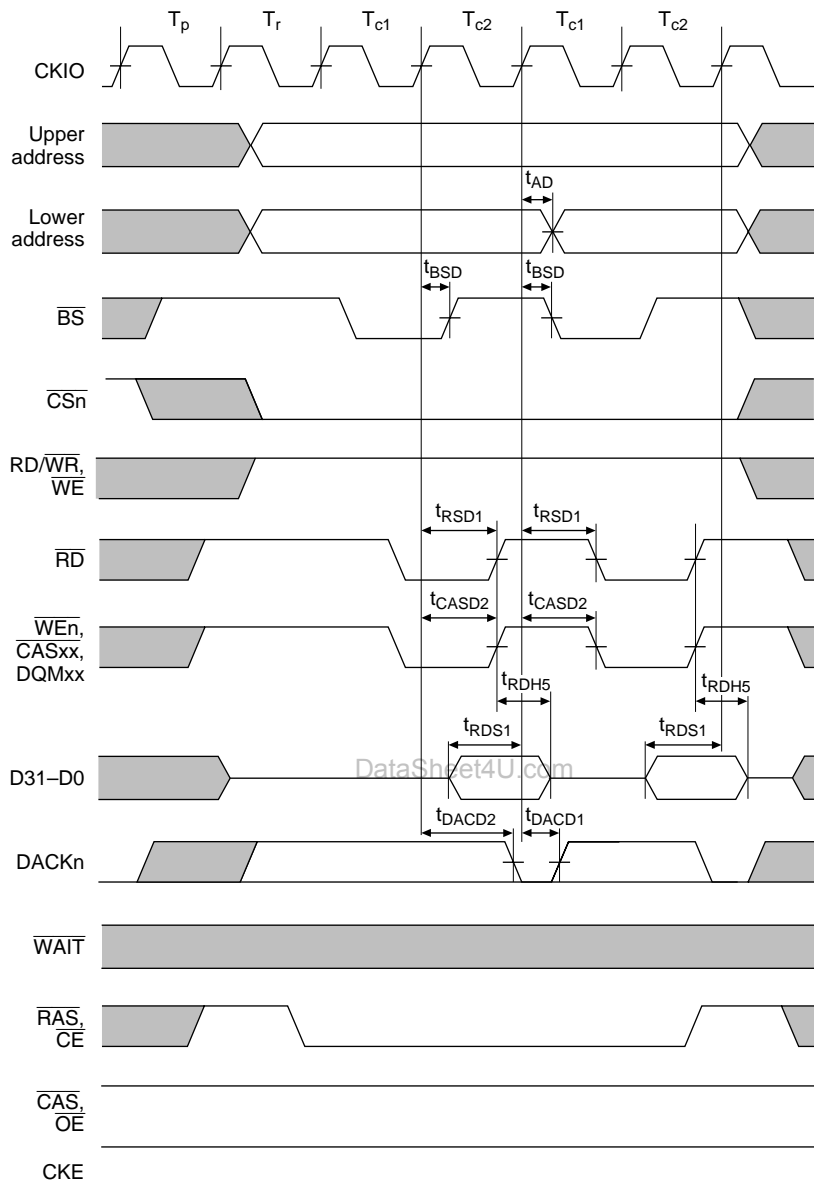

- Notes: 1. t_{RDH5} is specified from the rise of \overline{RD} or \overline{CASxx} , whichever is first.
 2. The \overline{DACKn} waveform shown is for the case where active-high has been specified.

Figure 15.44 DRAM Burst Read Cycle
 (TRP = 1 Cycle, RCD = 1 Cycle, No Waits, PLL On)

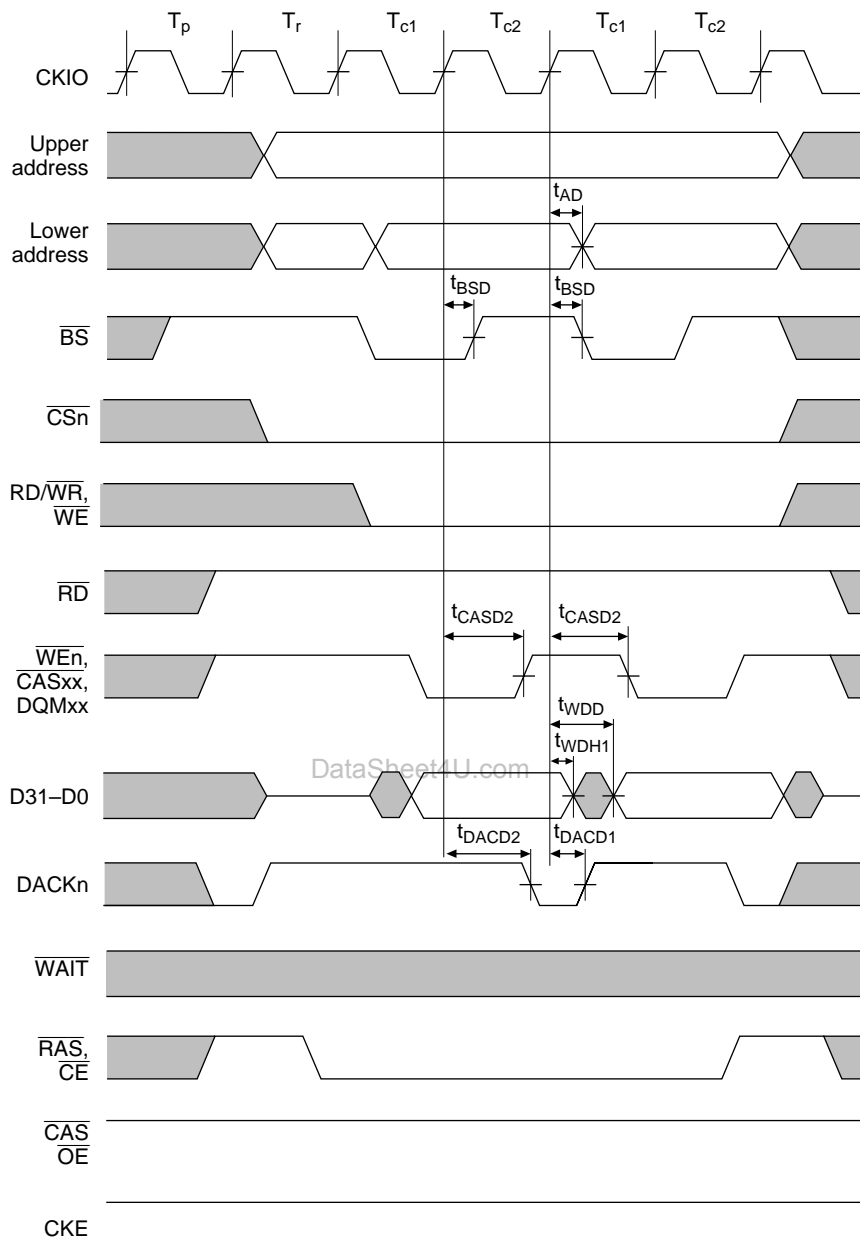

Note: The DACKn waveform shown is for the case where active-high has been specified.

Figure 15.45 DRAM Burst Write Cycle
(TRP = 1 Cycle, RCD = 1 Cycle, No Waits, PLL On)

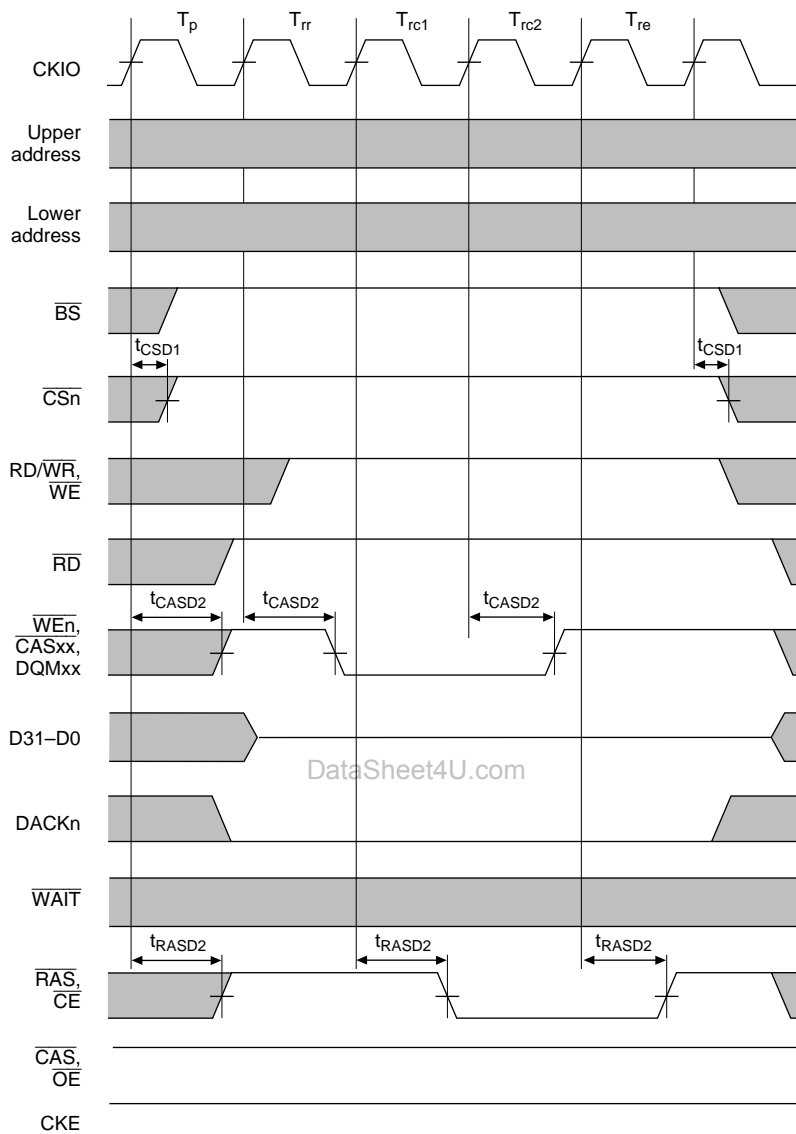
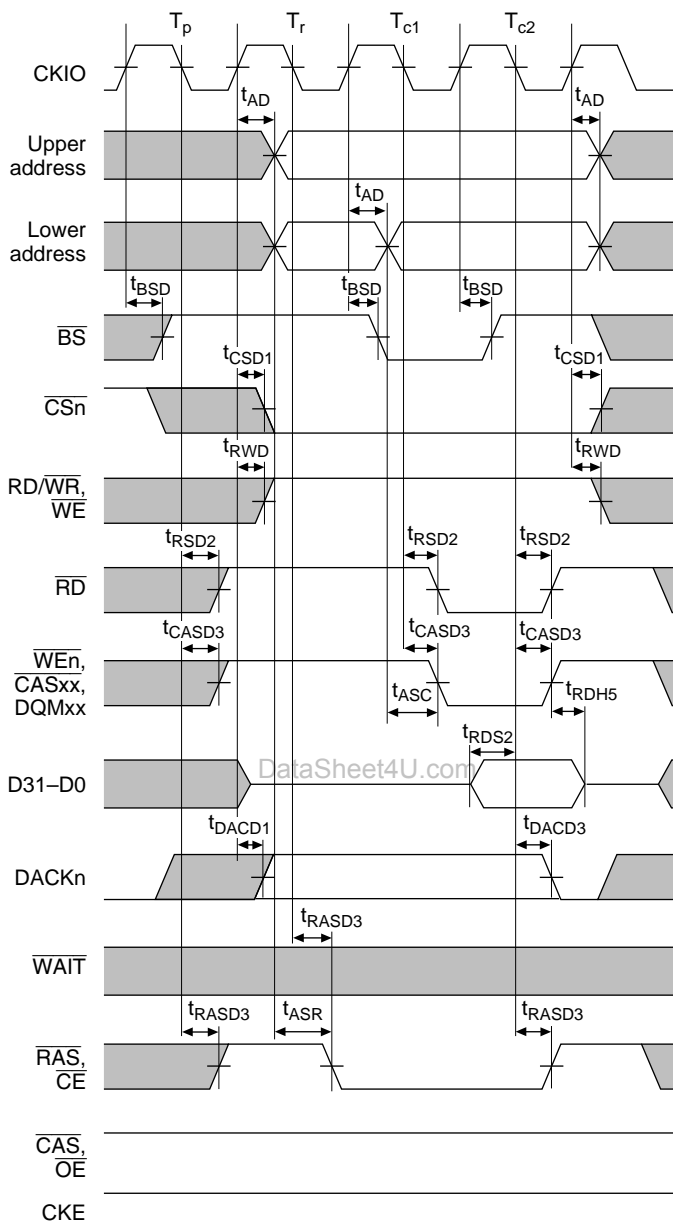
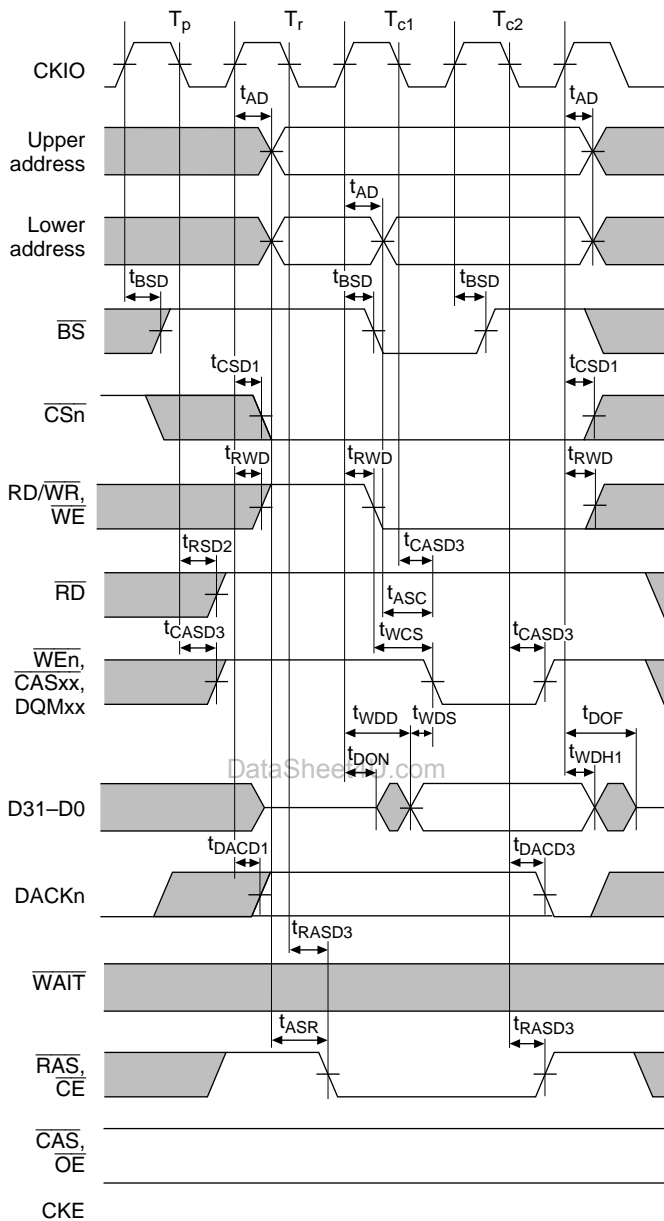

Figure 15.46 DRAM CAS-Before-RAS Refresh Cycle
 (TRP = 1 Cycle, TRAS = 2 Cycles, PLL On)



- Notes: 1. t_{RDH5} is specified from the rise of \overline{RD} or \overline{CASxx} , whichever is first.
 2. The \overline{DACKn} waveform shown is for the case where active-high has been specified.

Figure 15.47 DRAM Read Cycle (TRP = 1 Cycle, RCD = 1 Cycle, No Waits, PLL Off)



Note: The DACKn waveform shown is for the case where active-high has been specified.

Figure 15.48 DRAM Write Cycle (TRP = 1 Cycle, RCD = 1 Cycle, No Waits, PLL Off)

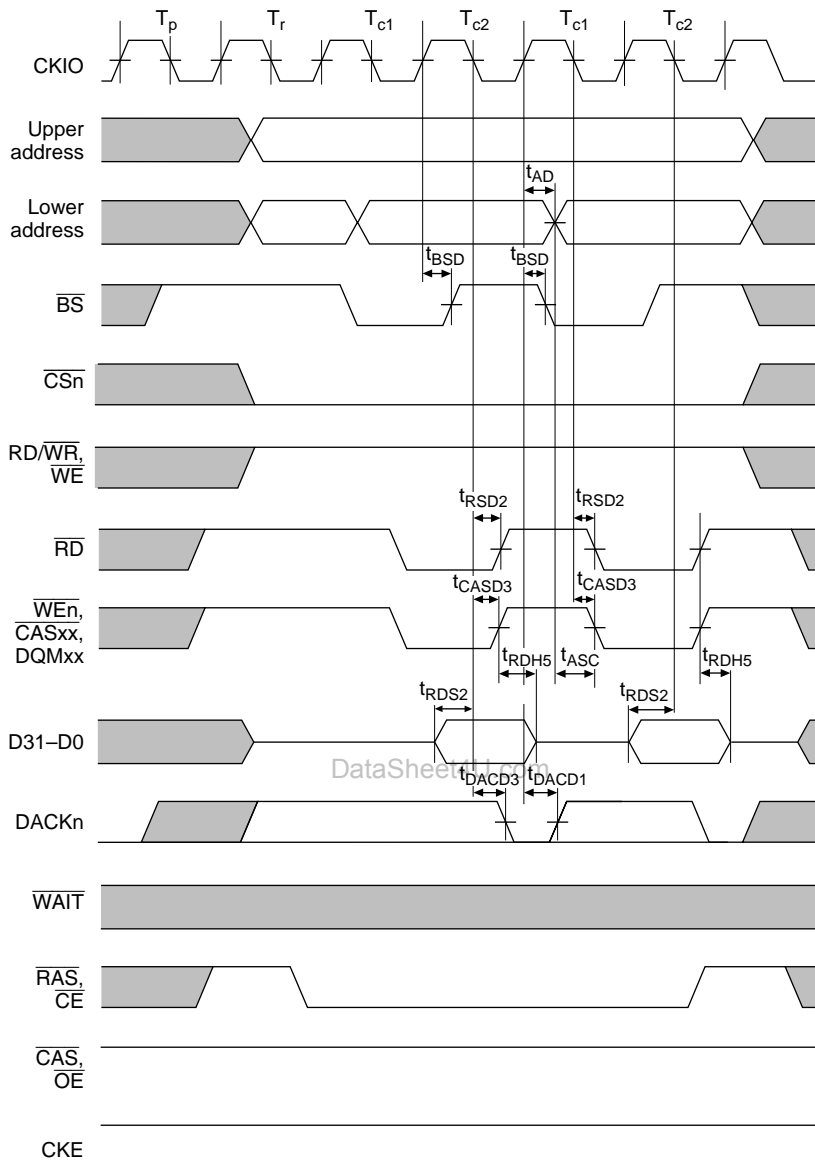

- Notes: 1. t_{RDH5} is specified from the rise of \overline{RD} or \overline{CASxx} , whichever is first.
 2. The DACKn waveform shown is for the case where active-high has been specified.

Figure 15.49 DRAM Burst Read Cycle
 (TRP = 1 Cycle, RCD = 1 Cycle, No Waits, PLL Off)

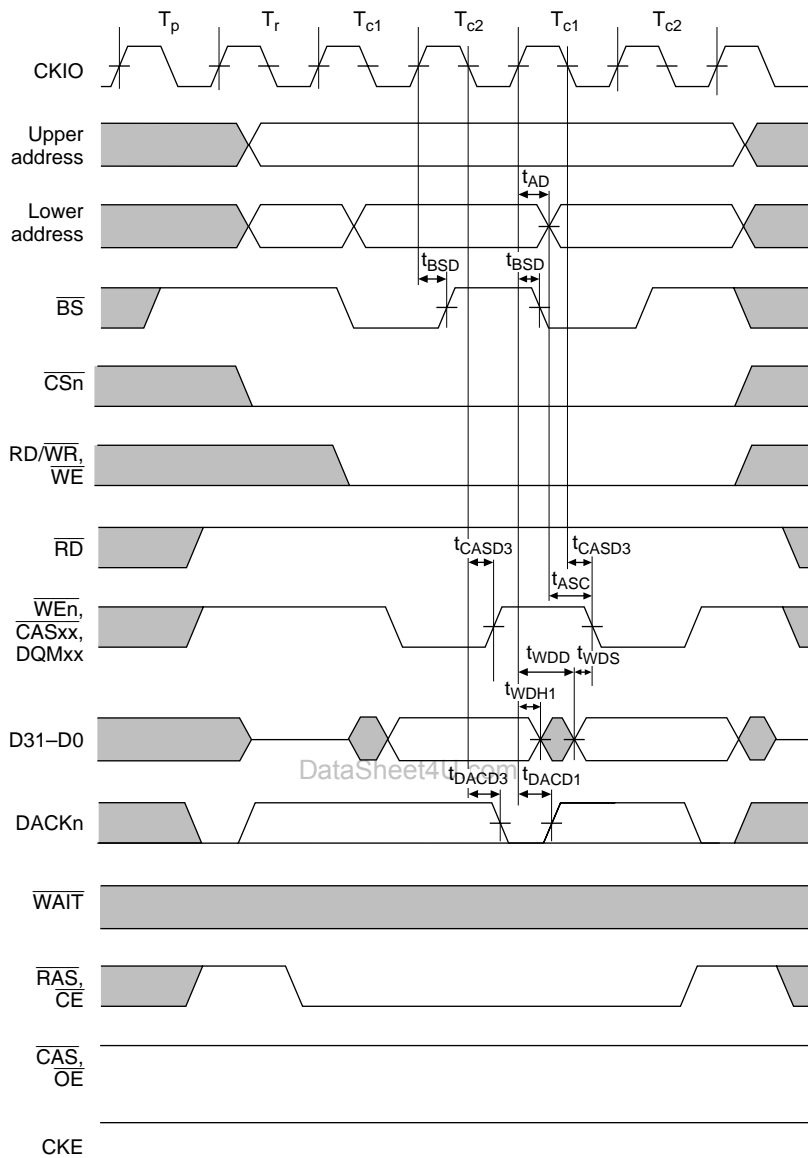

Note: The DACKn waveform shown is for the case where active-high has been specified.

Figure 15.50 DRAM Burst Write Cycle
(TRP = 1 Cycle, RCD = 1 Cycle, No Waits, PLL Off)

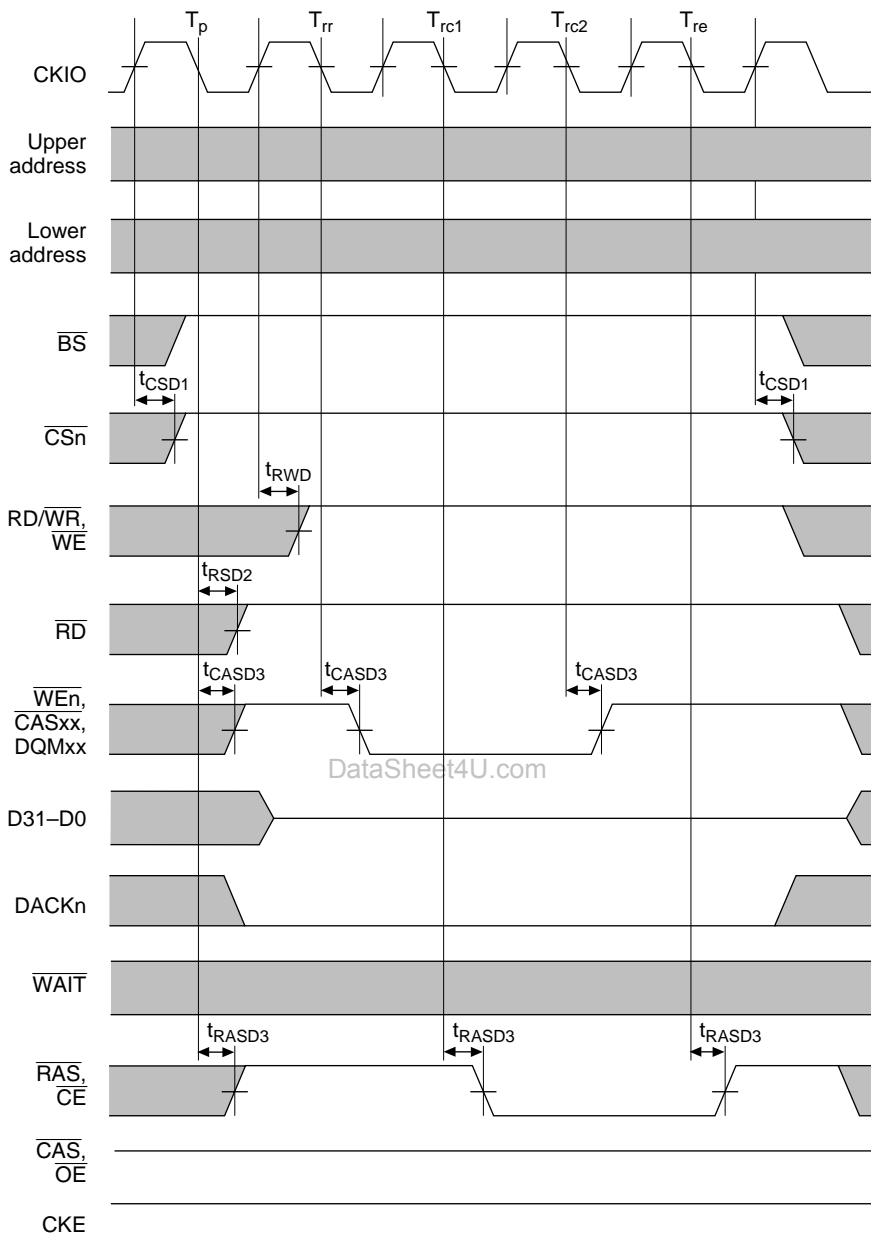
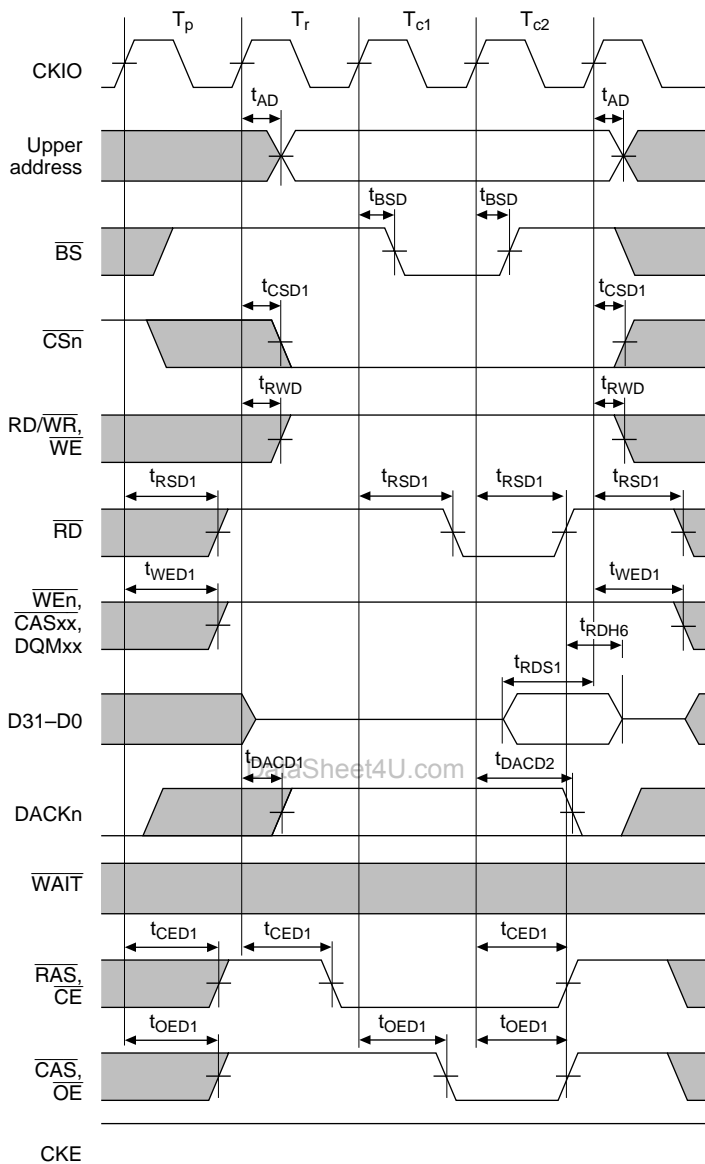
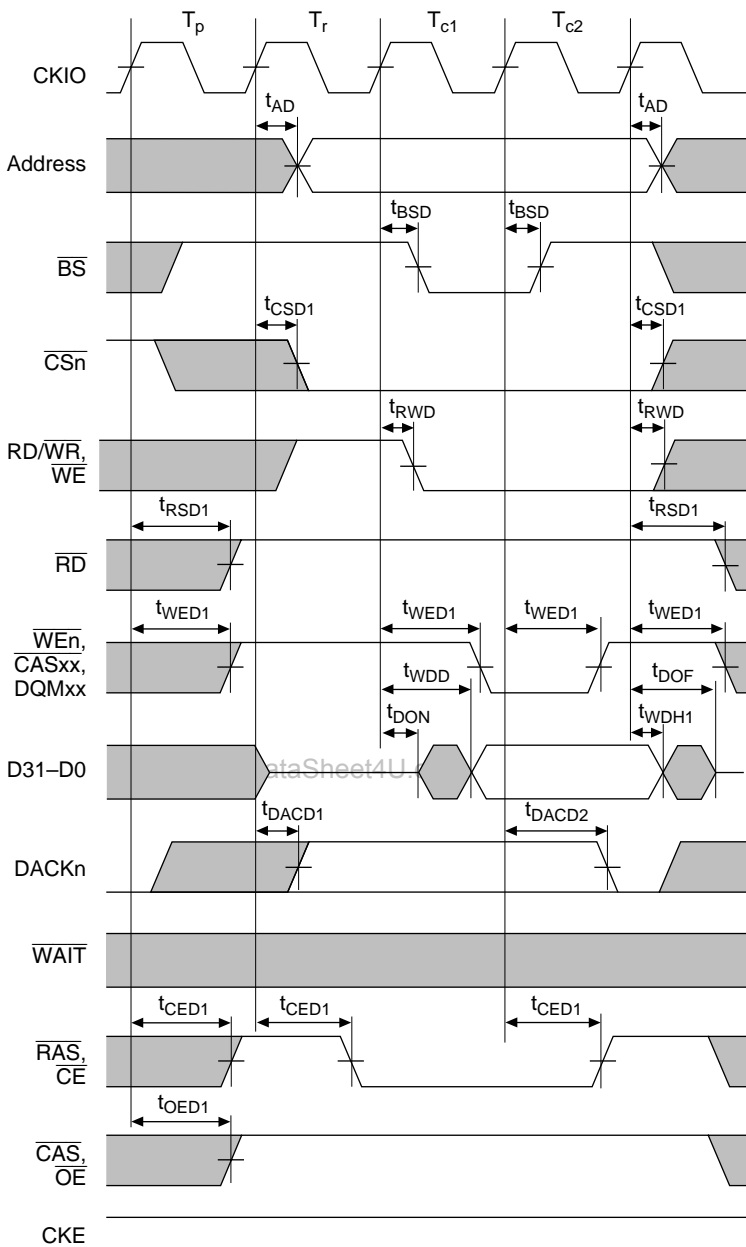

Figure 15.51 DRAM CAS-Before-RAS Refresh Cycle
(TRP = 1 Cycle, TRAS = 2 Cycles, PLL Off)



Note: The DACKn waveform shown is for the case where active-high has been specified.

Figure 15.52 Pseudo-SRAM Read Cycle
(PLL On, TRP = 1 Cycle, RCD = 1 Cycle, No Waits)



Note: The DACKn waveform shown is for the case where active-high has been specified.

Figure 15.53 Pseudo-SRAM Write Cycle
 (PLL On, TRP = 1 Cycle, RCD = 1 Cycle, No Waits)

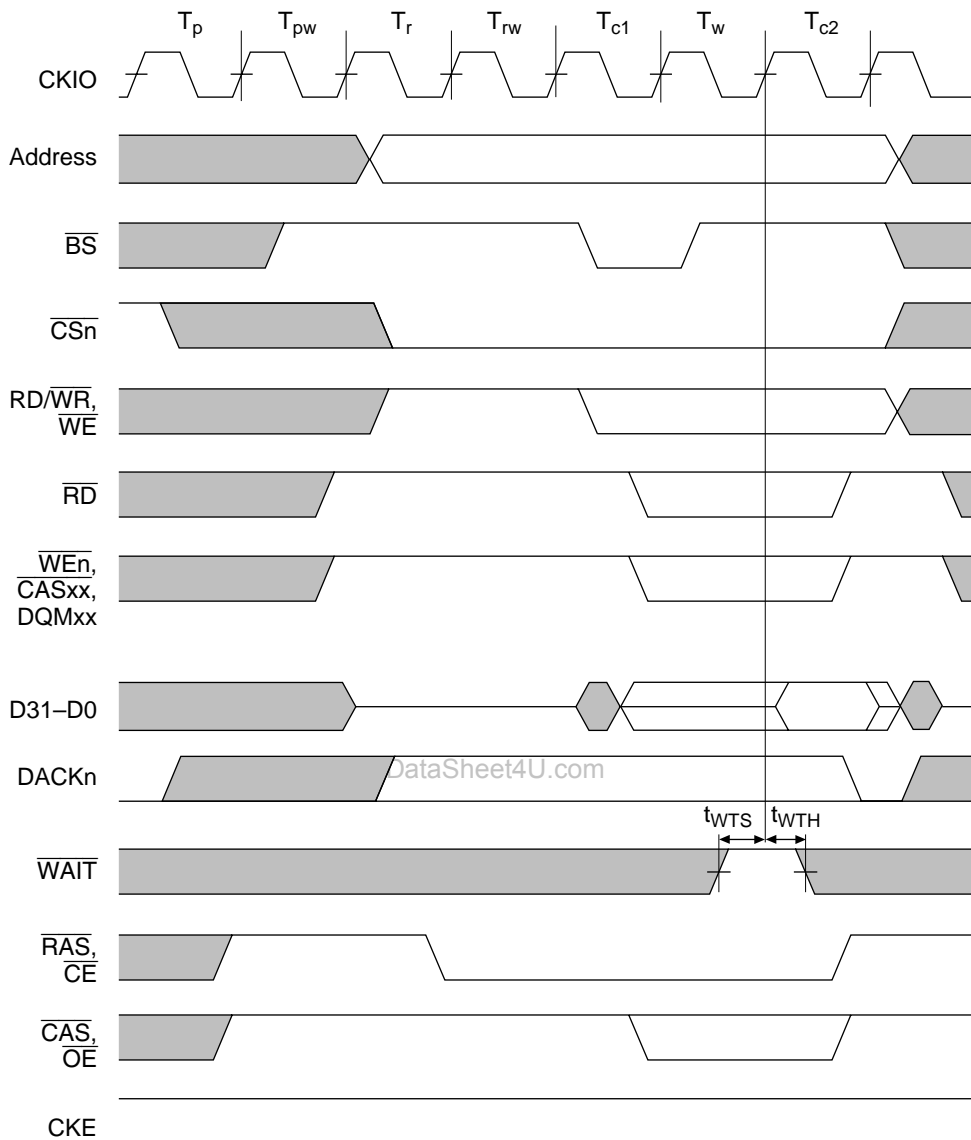

Note: The DACKn waveform shown is for the case where active-high has been specified.

Figure 15.54 Pseudo-SRAM Bus Cycle (TRP = 2 Cycles, RCD = 2 Cycles, 1 Wait)

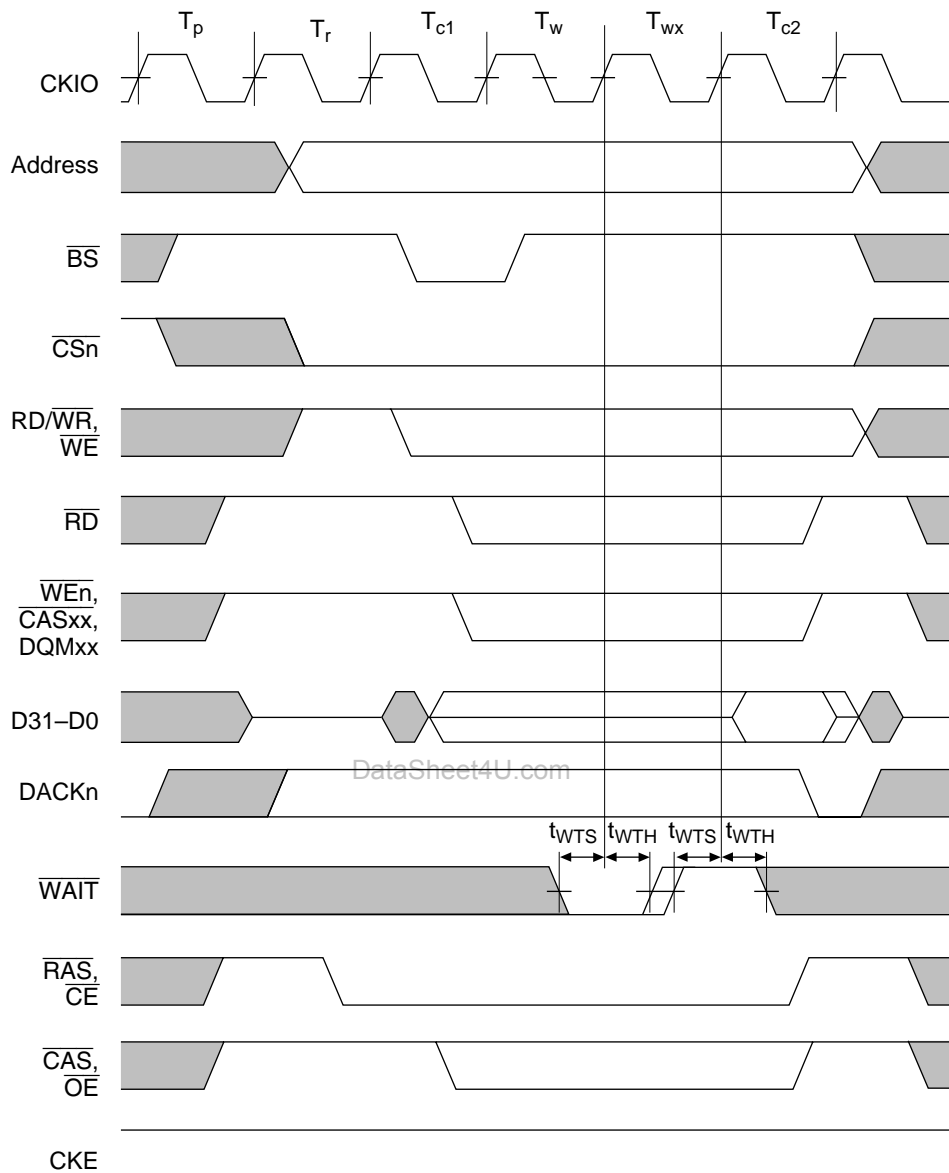

Note: The DACK_n waveform shown is for the case where active-high has been specified.

Figure 15.55 Pseudo-SRAM Bus Cycle
 (TRP = 1 Cycle, RCD = 1 Cycle, External Wait Input)

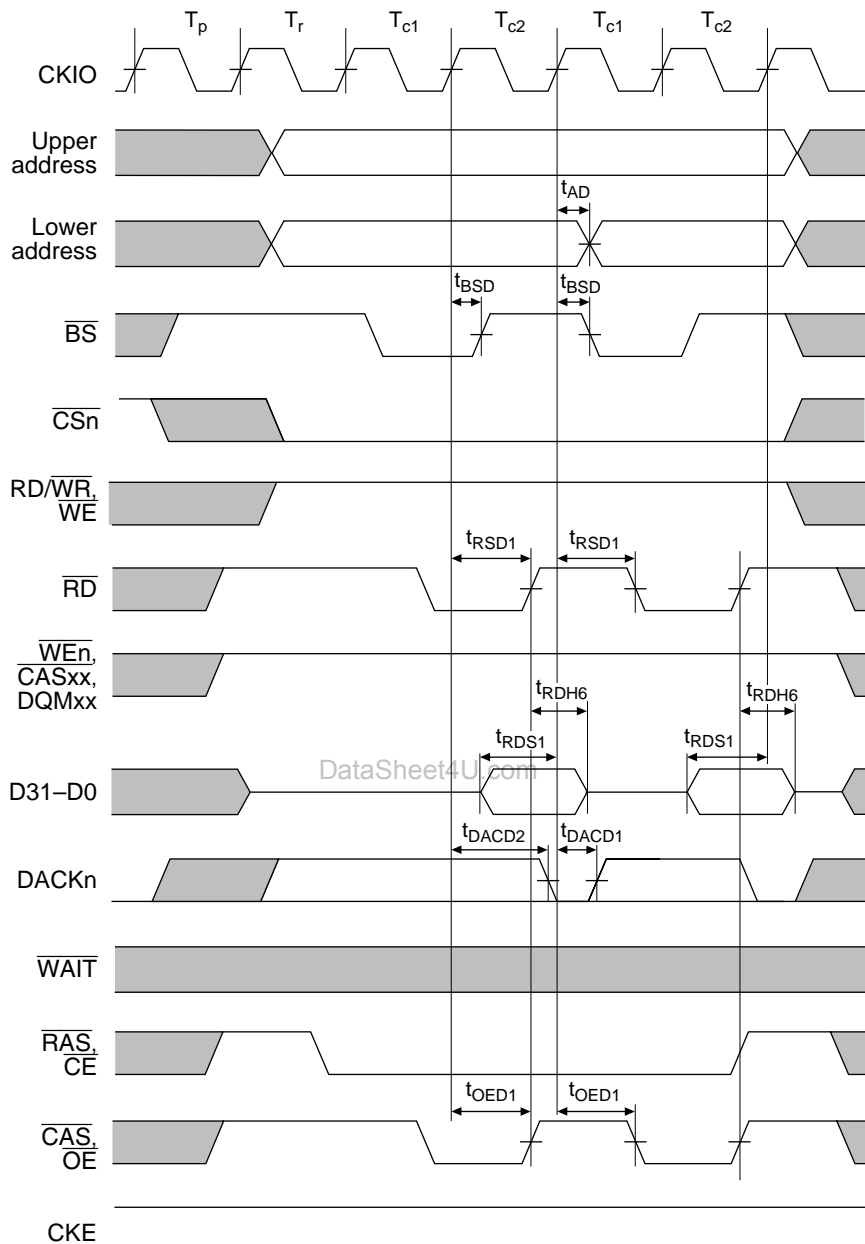

Note: The DACKn waveform shown is for the case where active-high has been specified.

Figure 15.56 Pseudo-SRAM Read Cycle
 (Static Column Mode, PLL On, TRP = 1 Cycle, RCD = 1 Cycle, No Waits)

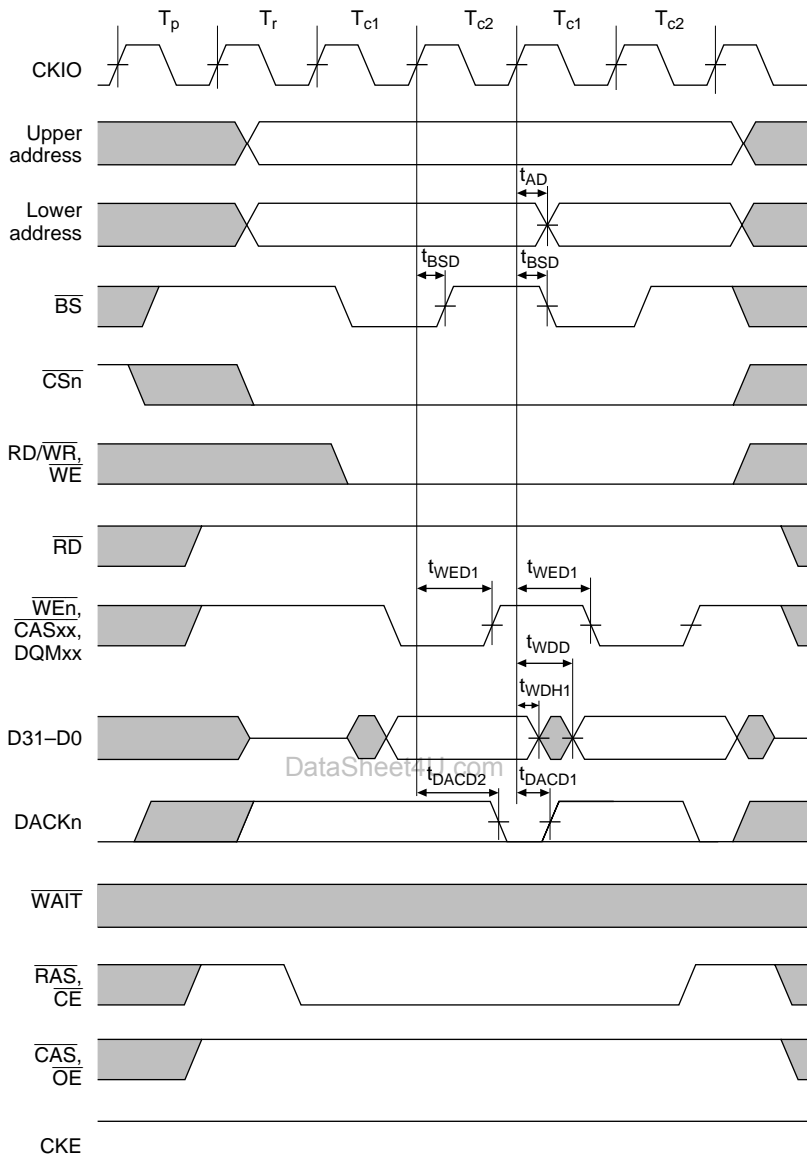

Note: The DACKn waveform shown is for the case where active-high has been specified.

Figure 15.57 Pseudo-SRAM Write Cycle
 (Static Column Mode, PLL On, TRP = 1 Cycle, RCD = 1 Cycle, No Waits)

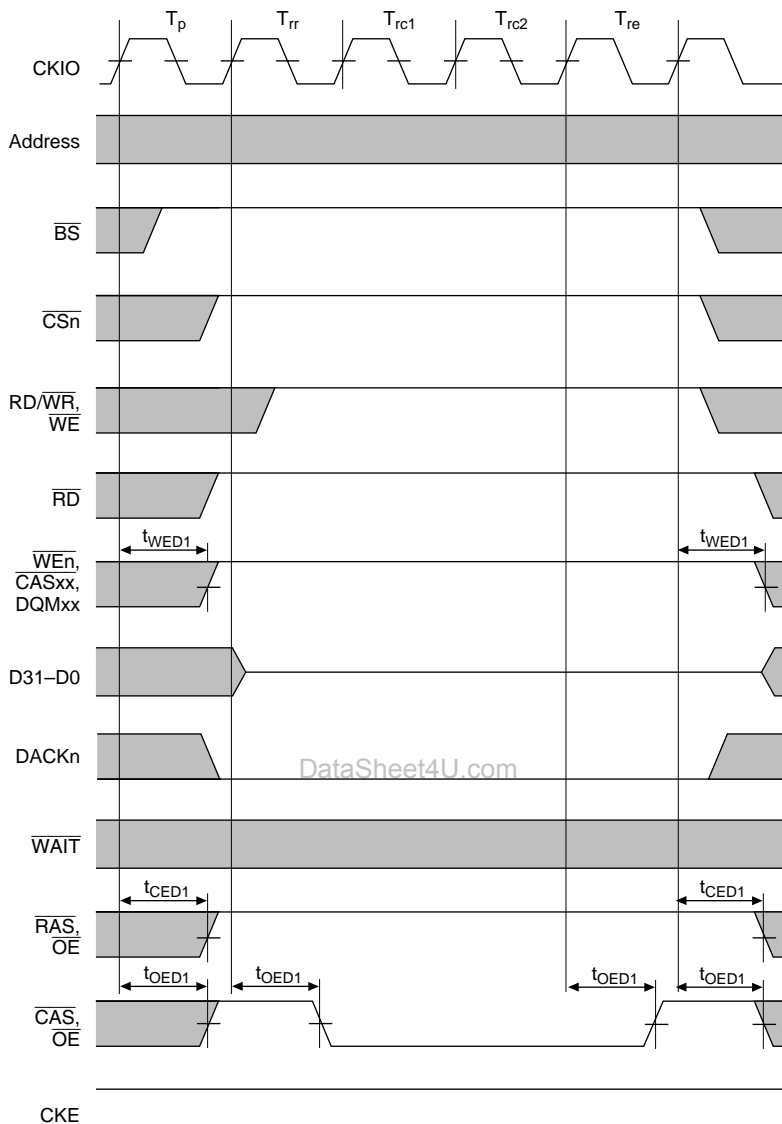

**Figure 15.58 Pseudo-SRAM Auto-Refresh Cycle
(PLL On, TRP = 1 Cycle, TRAS = 2 Cycles)**

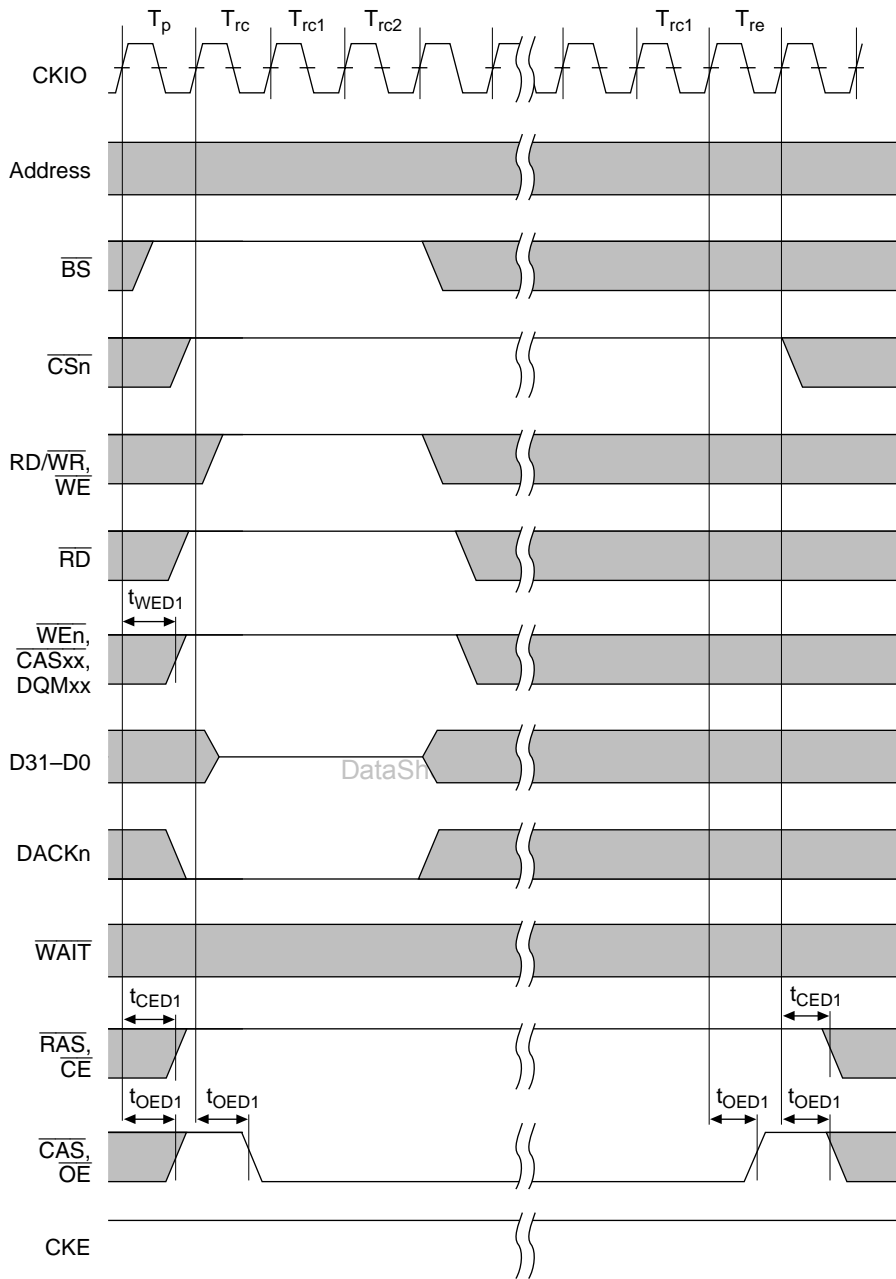
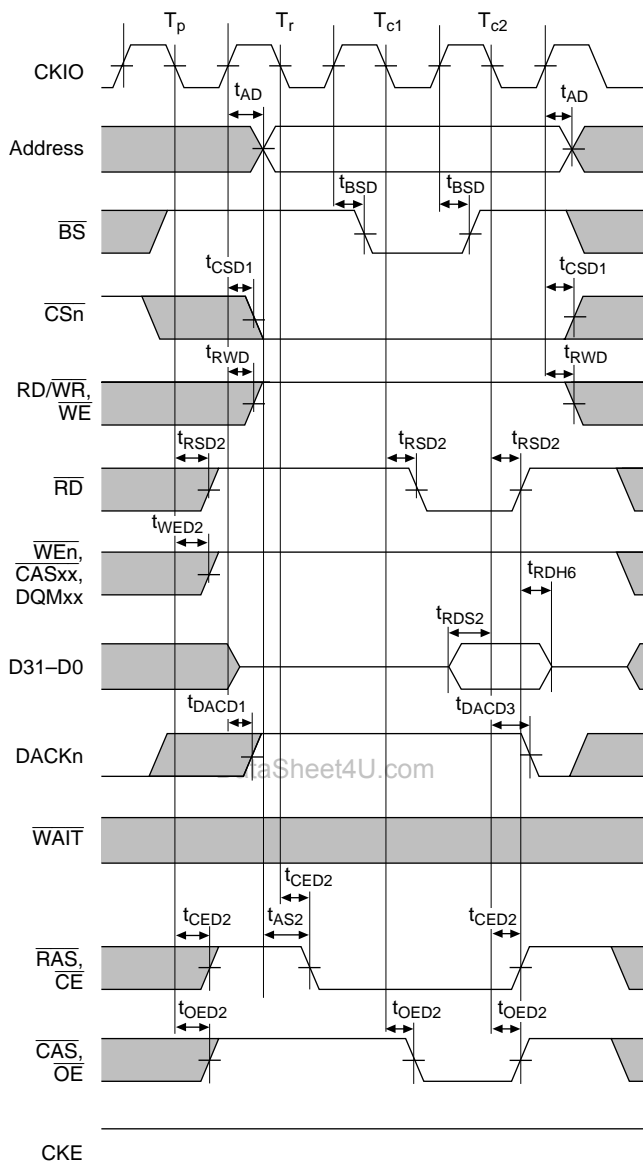
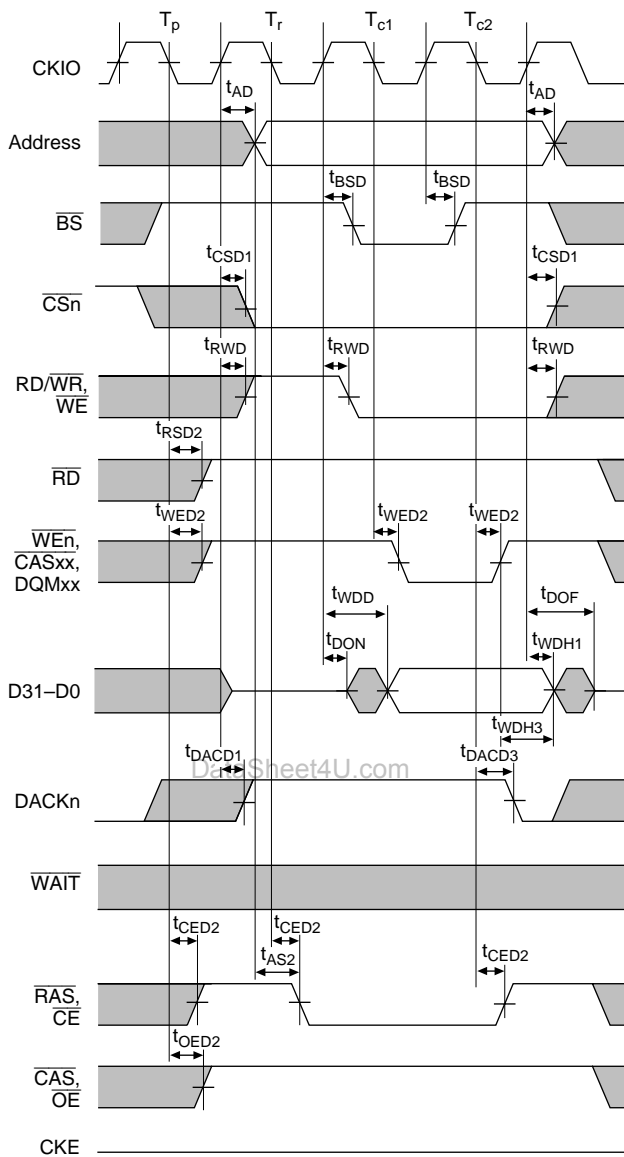

Figure 15.59 Pseudo-SRAM Self-Refresh Cycle
 (PLL On, TRP = 1 Cycle, TRAS = 2 Cycles)



Note: The DACKn waveform shown is for the case where active-high has been specified.

Figure 15.60 Pseudo-SRAM Read Cycle
(PLL Off, TRP = 1 Cycle, RCD = 1 Cycle, No Waits)



Note: The DACKn waveform shown is for the case where active-high has been specified.

Figure 15.61 Pseudo-SRAM Write Cycle
(PLL Off, TRP = 1 Cycle, RCD = 1 Cycle, No Waits)

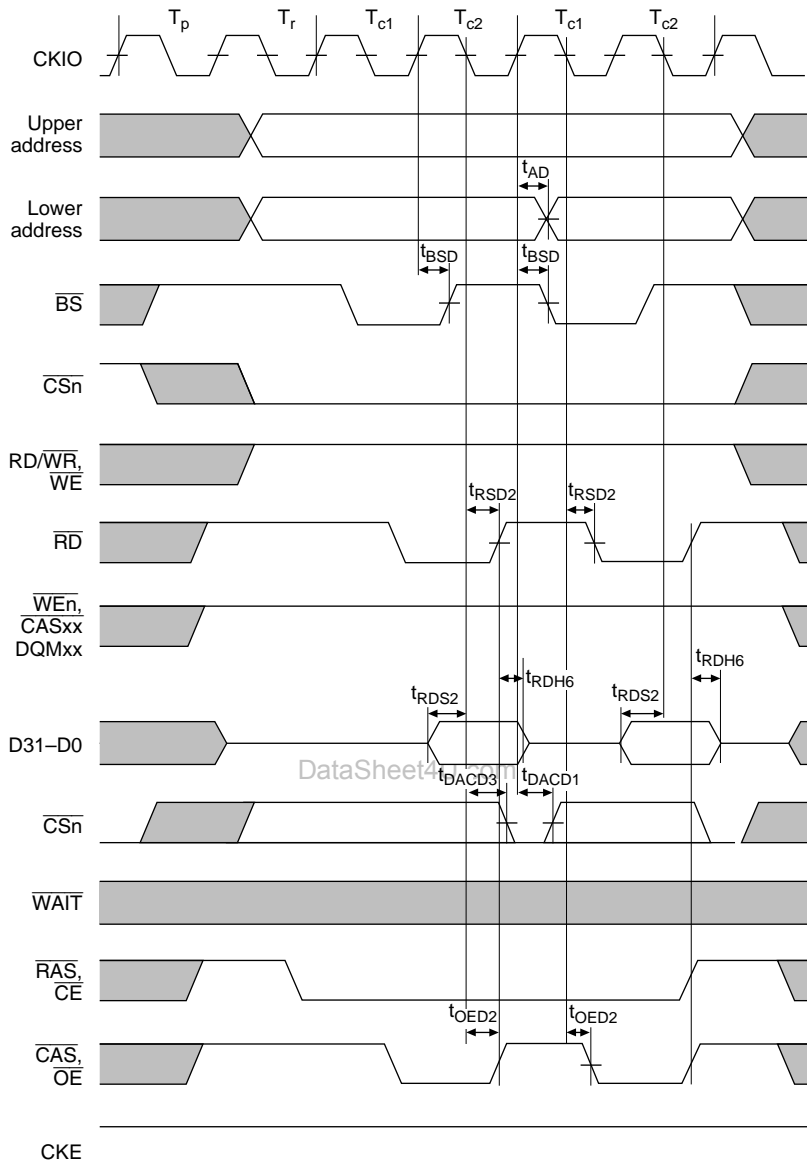

Note: The DACKn waveform shown is for the case where active-high has been specified.

Figure 15.62 Pseudo-SRAM Read Cycle
 (Static Column Mode, PLL Off, TRP = 1 Cycle, RCD = 1 Cycle, No Waits)

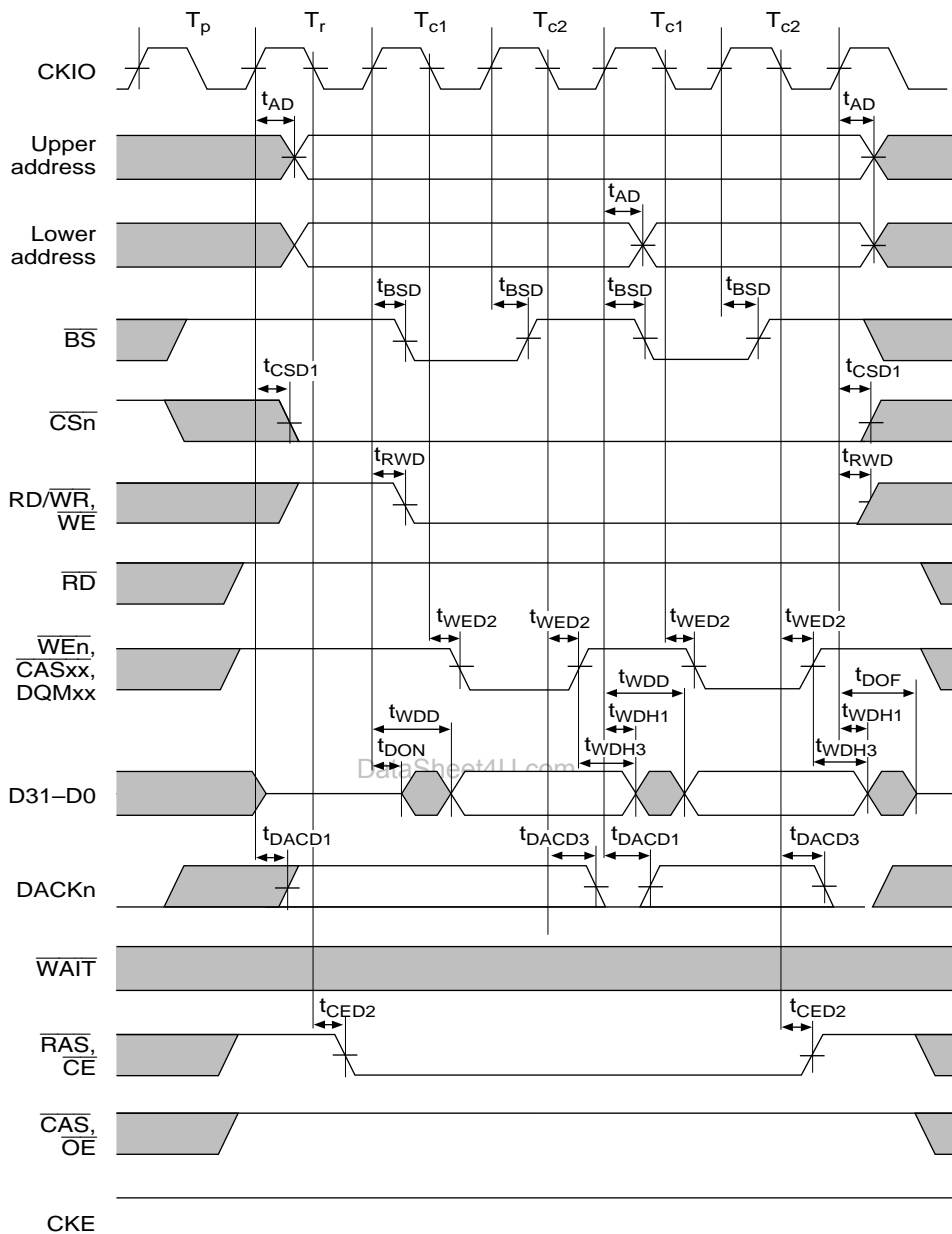

Note: The DACKn waveform shown is for the case where active-high has been specified.

Figure 15.63 Pseudo-SRAM Write Cycle

(Static Column Mode, PLL Off, TRP = 1 Cycle, RCD = 1 Cycle, No Waits)

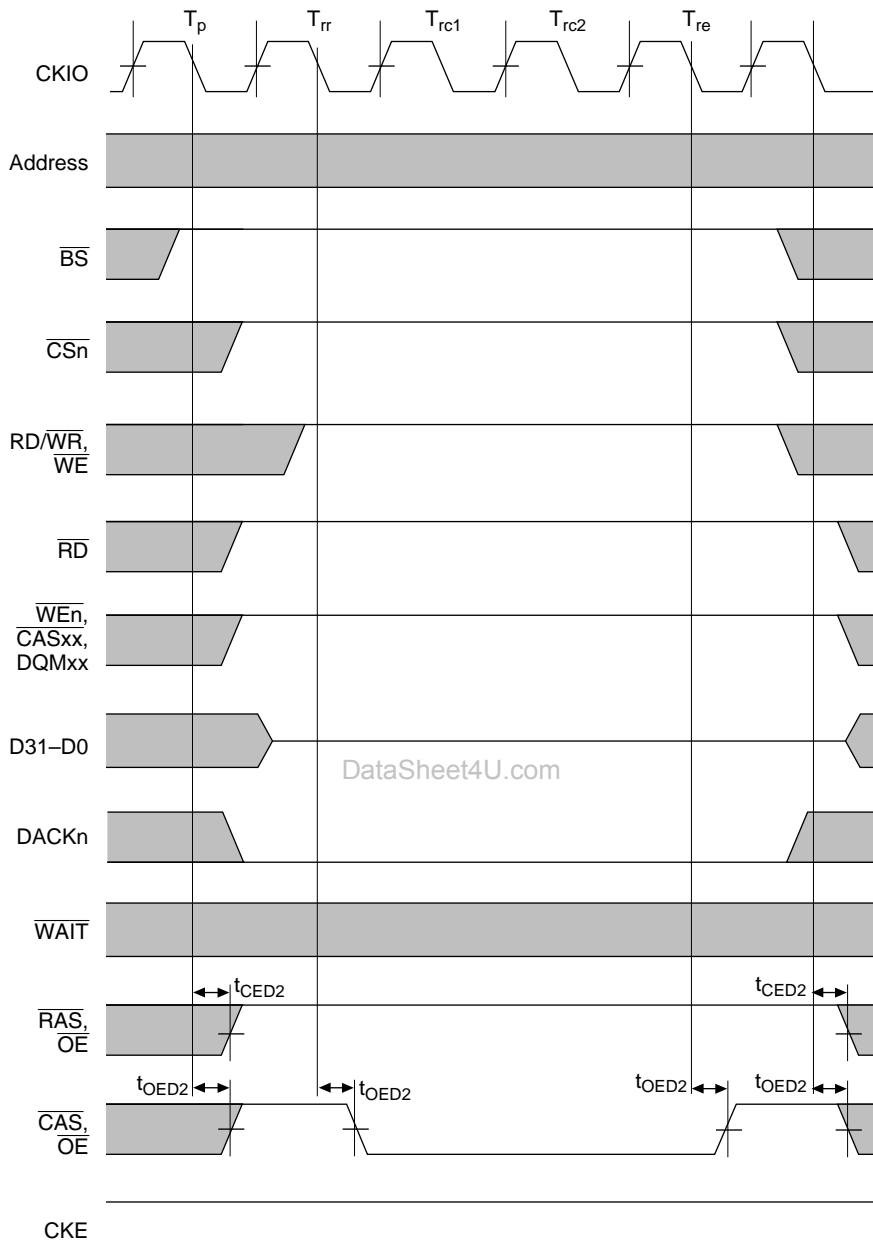

Figure 15.64 Pseudo-SRAM Auto-Refresh Cycle
 (PLL Off, TRP = 1 Cycle, TRAS = 2 Cycles)

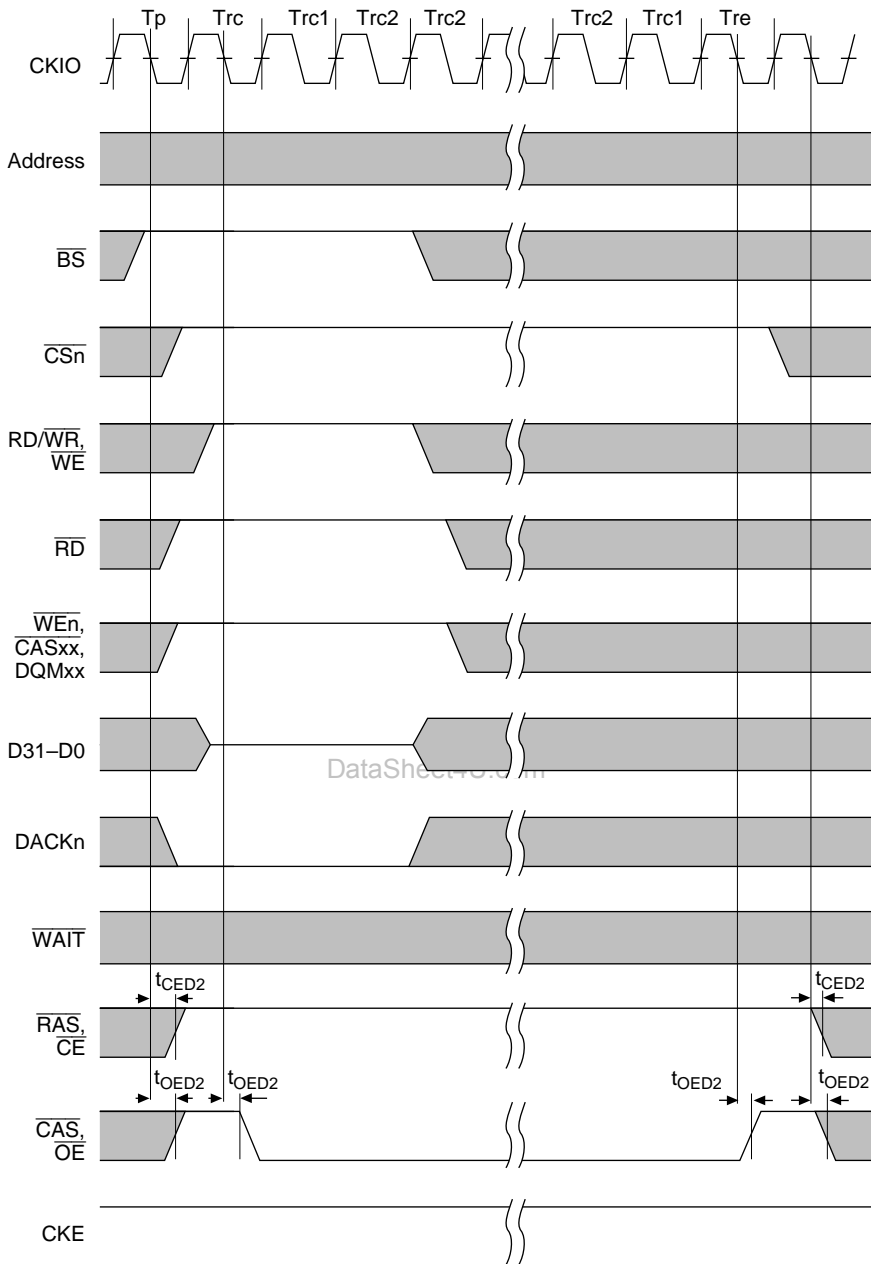
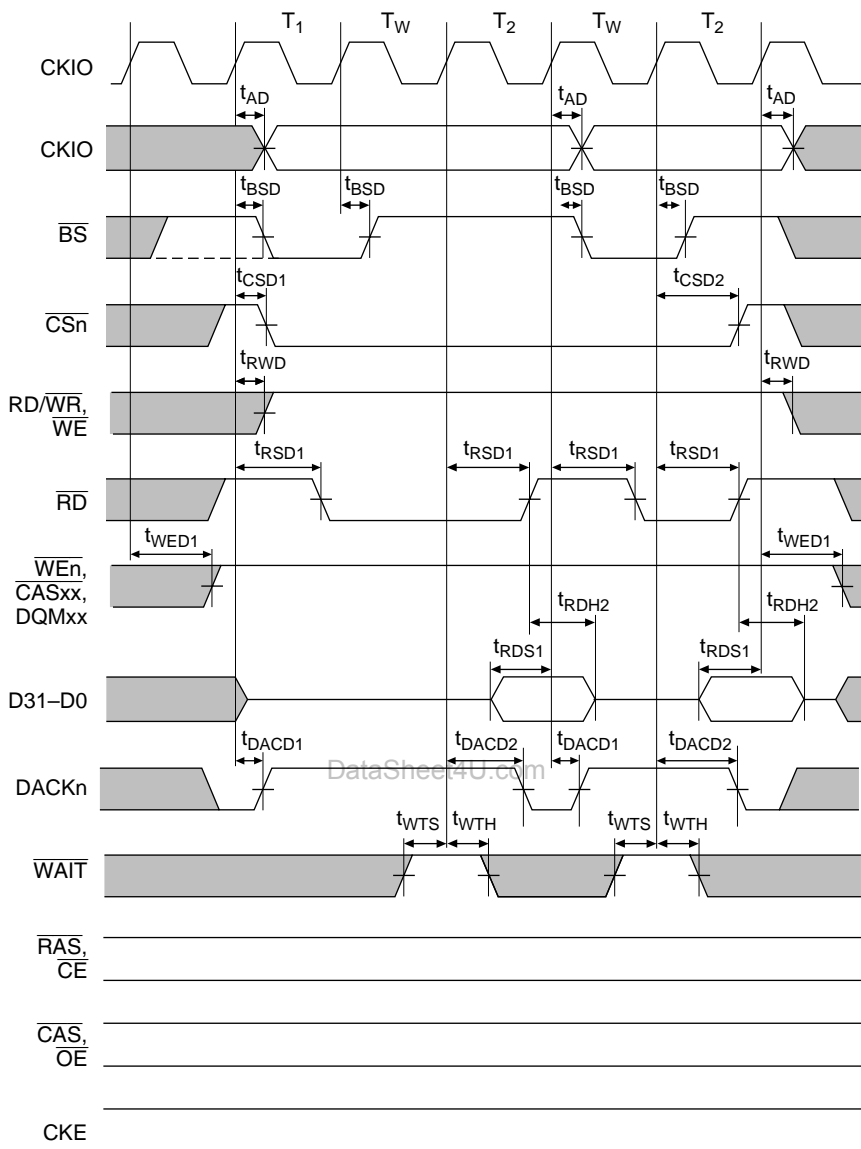
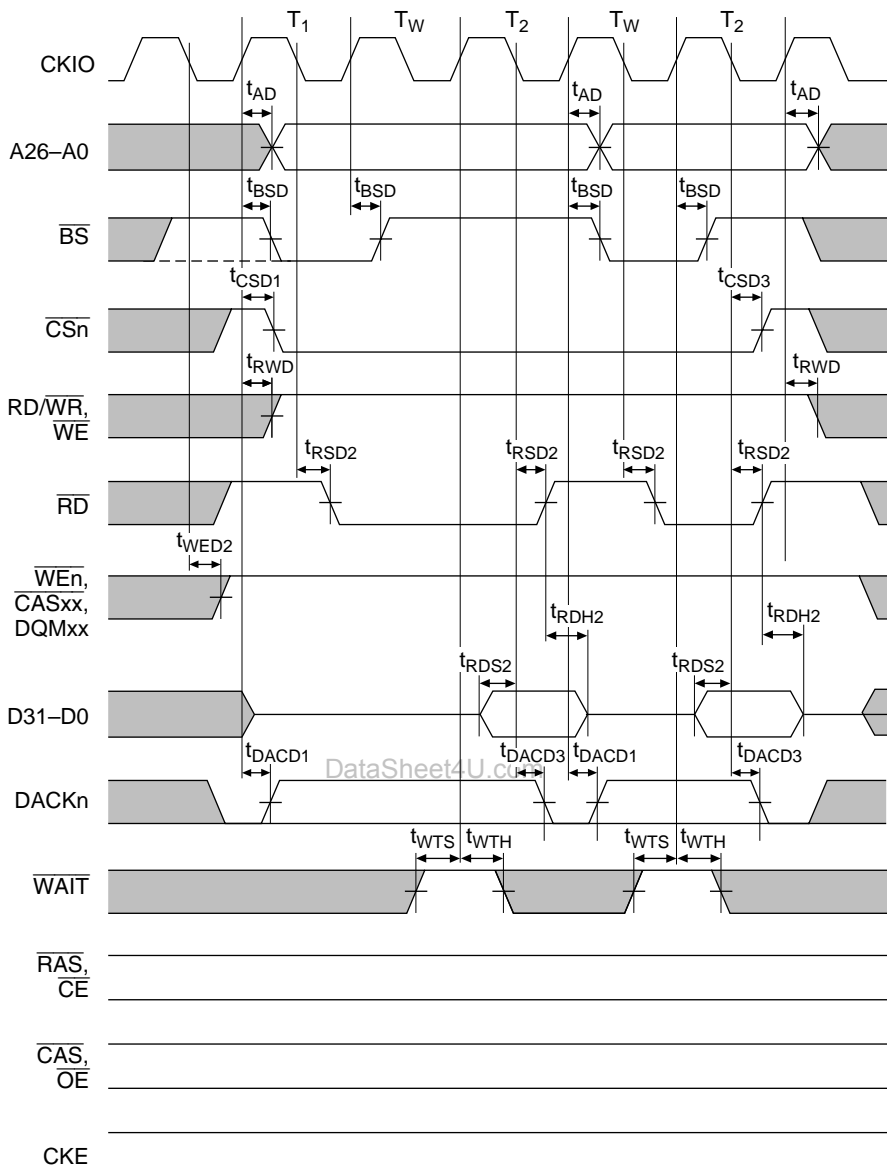

Figure 15.65 Pseudo-SRAM Self-Refresh Cycle
 (PLL Off, TRP = 1 Cycle, TRAS = 2 Cycles)



Note: The DACK_n waveform shown is for the case where active-high has been specified.

Figure 15.66 Burst ROM Read Cycle (PLL On, 1 Wait)



Note: The DACKn waveform shown is for the case where active-high has been specified.

Figure 15.67 Burst ROM Read Cycle (PLL Off, 1 Wait)

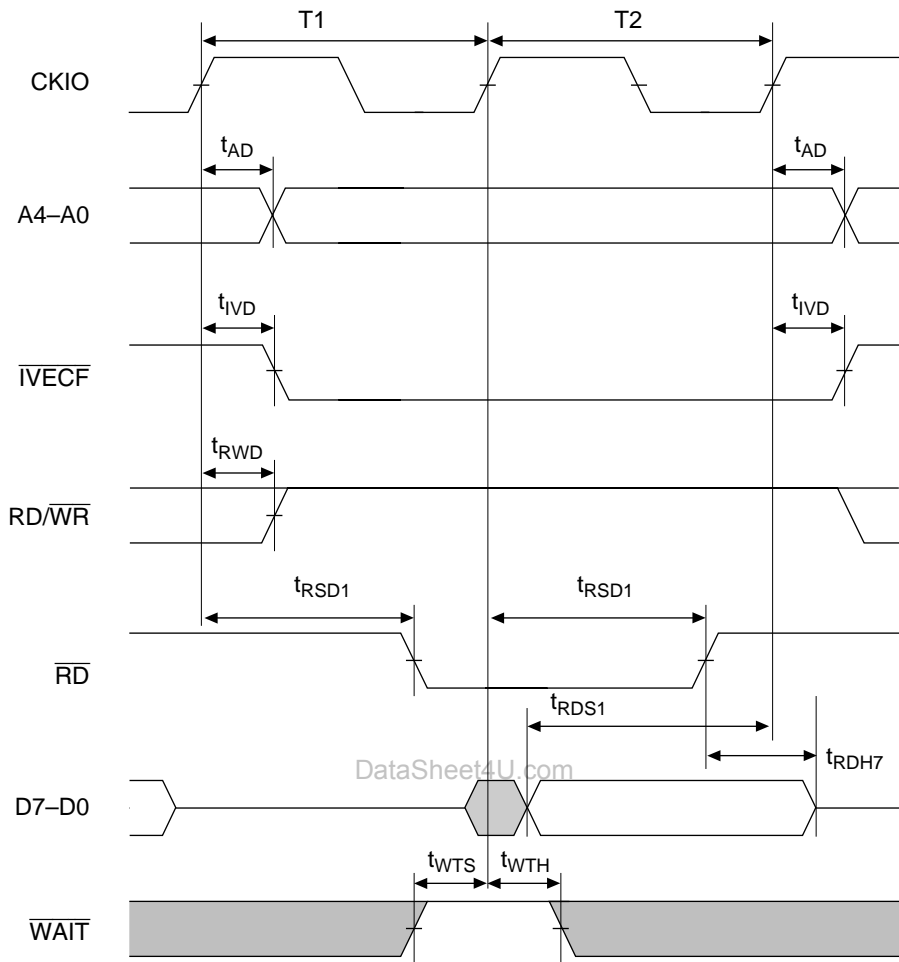

Figure 15.68 Interrupt Vector Fetch Cycle (PLL On, No Waits)

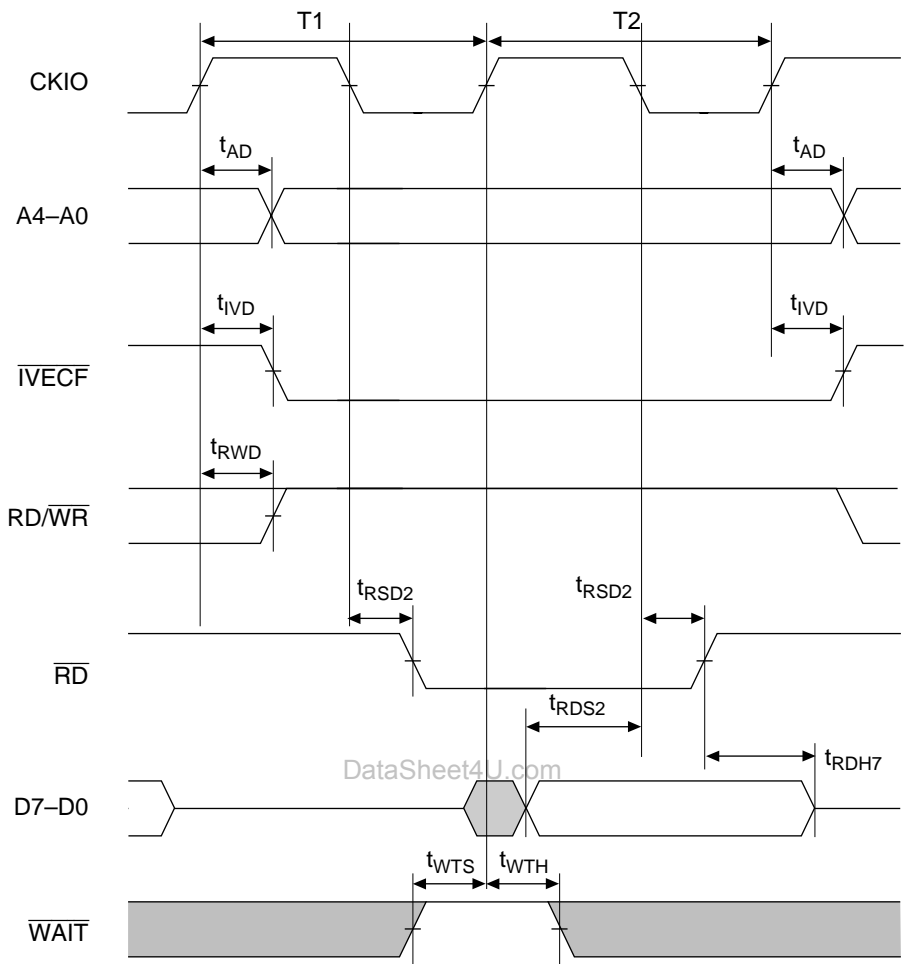

Figure 15.69 Interrupt Vector Fetch Cycle (PLL Off, No Waits)

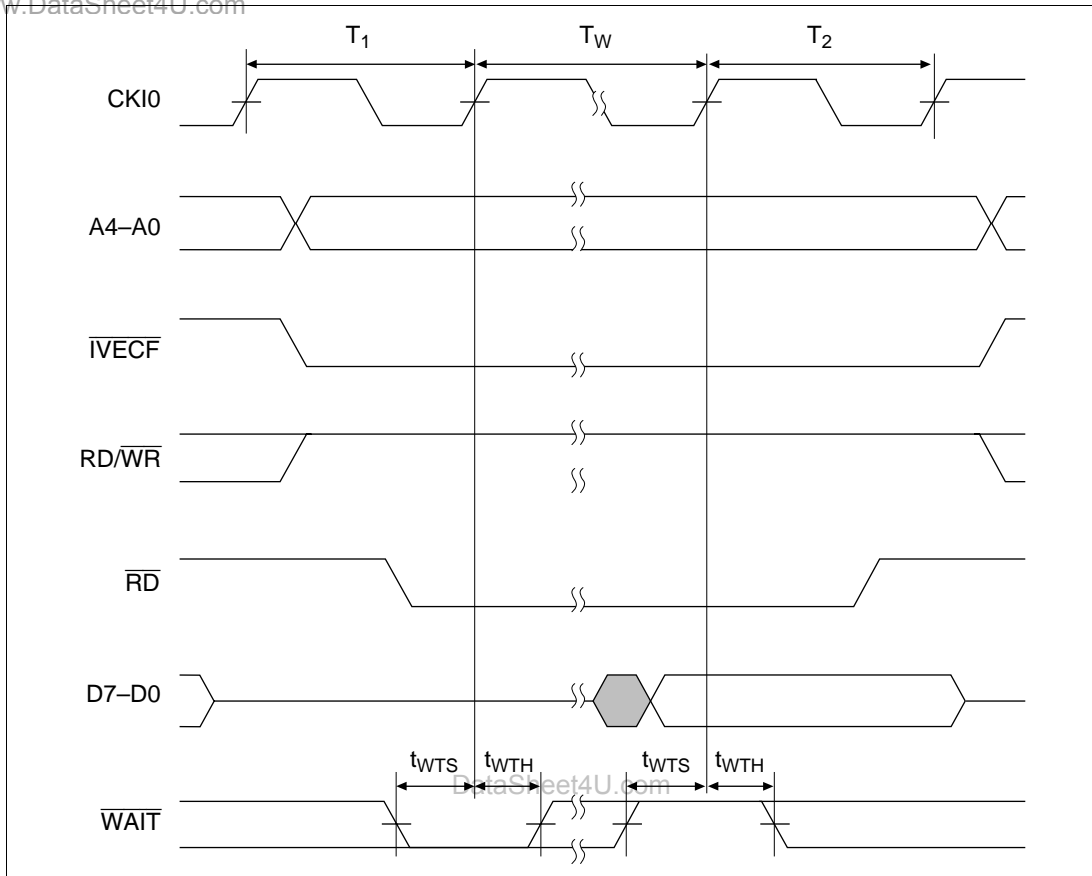

Figure 15.70 Interrupt Vector Fetch Cycle (1 External Wait Cycle)

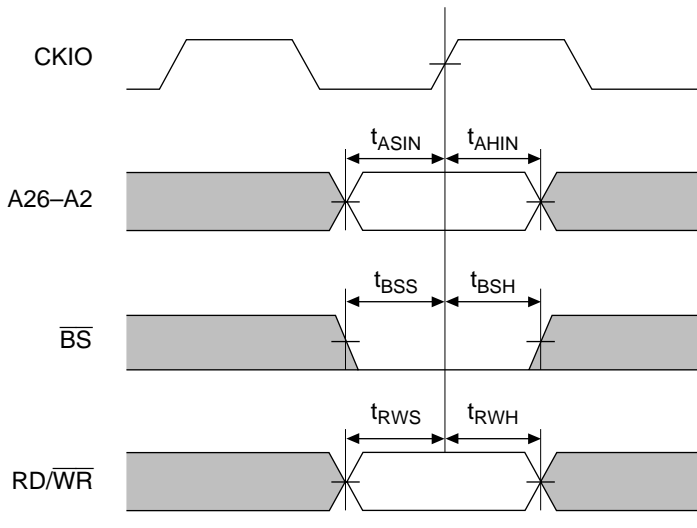

Figure 15.71 Address Monitor Cycle

Table 15.10 DMAC Timing (Conditions: $V_{CC} = 5.0\text{ V} \pm 10\%$, $T_a = -20$ to $+75^\circ\text{C}$)

Item	Symbol	Min	Max	Unit	Figure
DREQ0, DREQ1 setup time (PLL Off, On)	t_{DRQS}	30	—	ns	15.72
DREQ0, DREQ1 setup time (PLL On, 1/4 cycle delay)	t_{DRQS}	$30 - 1/4\ t_{cyc}$	—	ns	
DREQ0, DREQ1 hold time (PLL Off, On)	t_{DRQH}	15	—	ns	
DREQ0, DREQ1 hold time (PLL On, 1/4 cycle delay)	t_{DRQH}	$1/4\ t_{cyc} + 15$	—	ns	
DREQ0, DREQ1 low level width	t_{DRQW}	1.5	—	t_{cyc}	

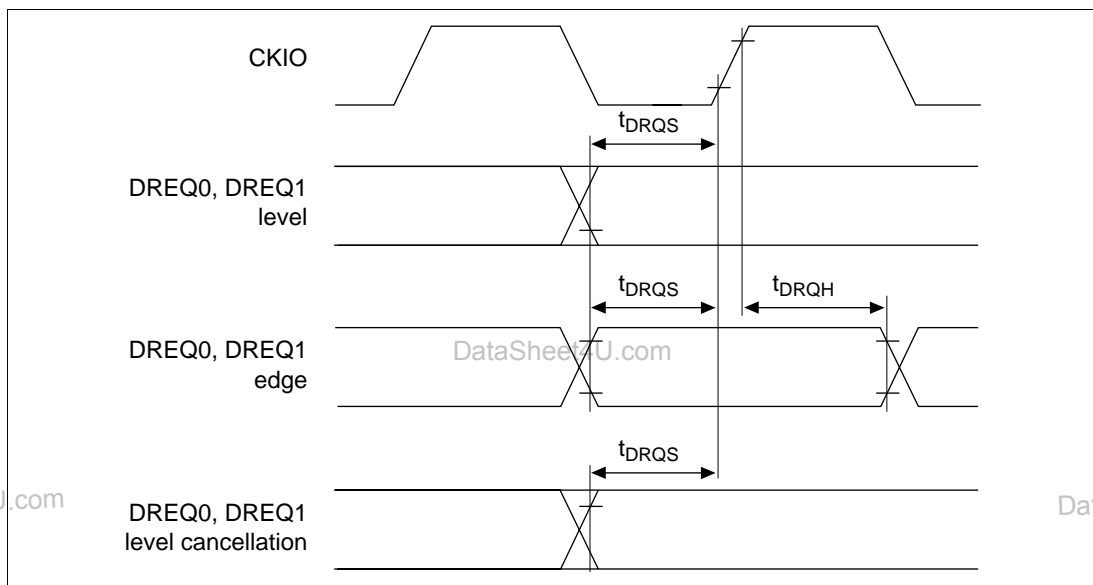

Figure 15.72 DREQ0, DREQ1 Input Timing

15.3.5 Free-Running Timer Timing

Table 15.11 Free-Running Timer Timing (Conditions: $V_{CC} = 5.0\text{ V} \pm 10\%$, $T_a = -20$ to $+75^\circ\text{C}$)

Item	Symbol	Min	Max	Unit	Figure
Output compare output delay time (PLL Off, On)	t_{TOCD}	—	160	ns	15.73
Output compare output delay time (PLL On, 1/4 cycle delay)	t_{TOCD}	—	$1/4\text{ }t_{cyc} + 160$	ns	
Input capture input setup time (PLL Off, On)	t_{TICS}	80	—	ns	
Input capture input setup time (PLL On, 1/4 cycle delay)	t_{TICS}	$80 - 1/4\text{ }t_{cyc}$	—	ns	
Timer clock input setup time (PLL Off, On)	t_{TCKS}	80	—	ns	15.74
Timer clock input setup time (PLL On, 1/4 cycle delay)	t_{TCKS}	$80 - 1/4\text{ }t_{cyc}$	—	ns	
Timer clock pulse width (single edge)	t_{TCKWH}	4.5	—	t_{cyc}	
Timer clock pulse width (both edges)	t_{TCKWL}	8.5	—	t_{cyc}	

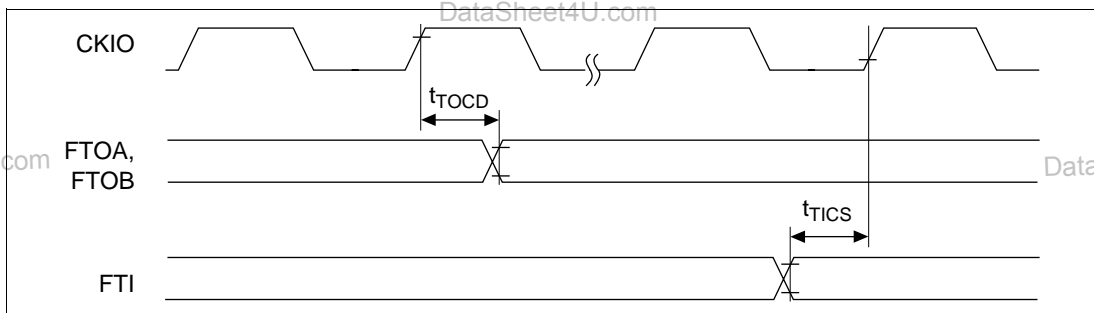

Figure 15.73 FRT Input/Output Timing

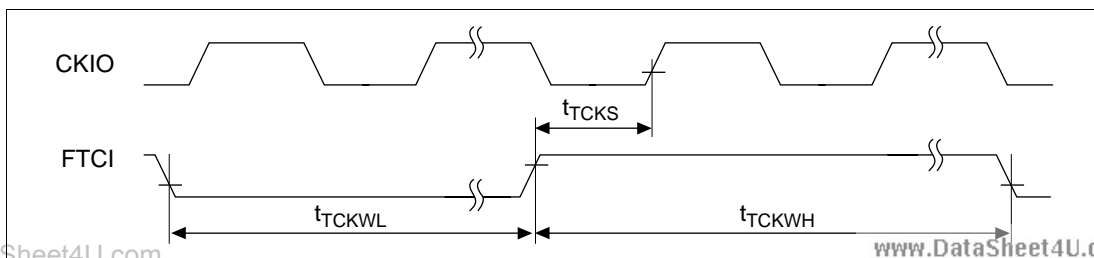

Figure 15.74 FRT Clock Input Timing

15.3.6 Watchdog Timer Timing

Table 15.12 Watchdog Timer Timing (Conditions: $V_{CC} = 5.0\text{ V} \pm 10\%$, $T_a = -20$ to $+75^\circ\text{C}$)

Item	Symbol	Min	Max	Unit	Figure
WDTOVF delay time (PLL Off, On)	t_{WDOVD}	—	70	ns	15.75
WDTOVF delay time (PLL On, 1/4 cycle delay)	t_{WDOVD}	—	$1/4\text{ tcyc} + 70$	ns	

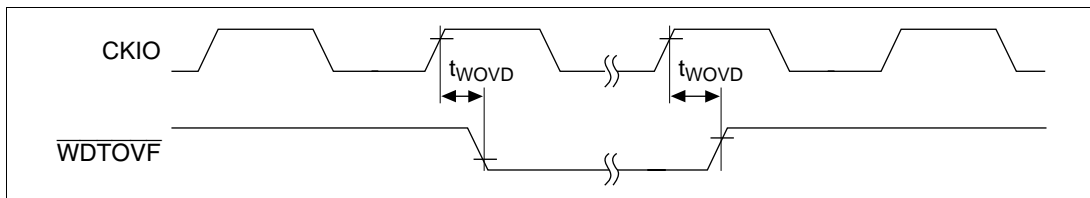

Figure 15.75 Watchdog Timer Output Timing

DataSheet4U.com

et4U.com

DataShee

DataSheet4U.com

www.DataSheet4U.com

15.3.7 Serial Communication Interface Timing

Table 15.13 Serial Communication Interface Timing

 (Conditions: $V_{CC} = 5.0\text{ V} \pm 10\%$, $T_a = -20\text{ to }+75^\circ\text{C}$)

Item	Symbol	Min	Max	Unit	Figure
Input clock cycle	t_{scyc}	16	—	t_{cyc}	15.76
Input clock cycle (clocked synchronous mode)	t_{scyc}	24	—	t_{cyc}	
Input clock pulse width	t_{sckw}	0.4	0.6	t_{scyc}	
Transmit data delay time (clocked synchronous mode)	t_{TXD}	—	70	ns	15.77
Receive data setup time (clocked synchronous mode)	t_{RXS}	70	—	ns	
Receive data hold time (clocked synchronous mode)	t_{RXH}	70	—	ns	

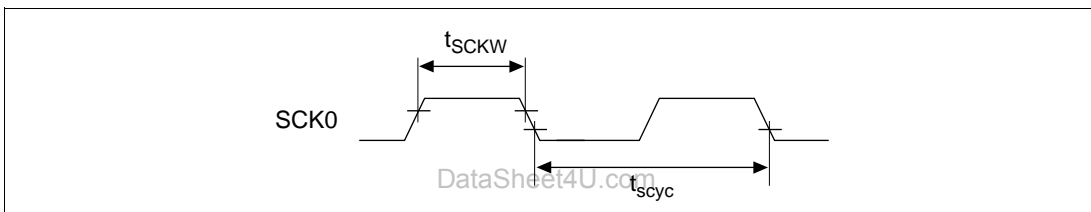
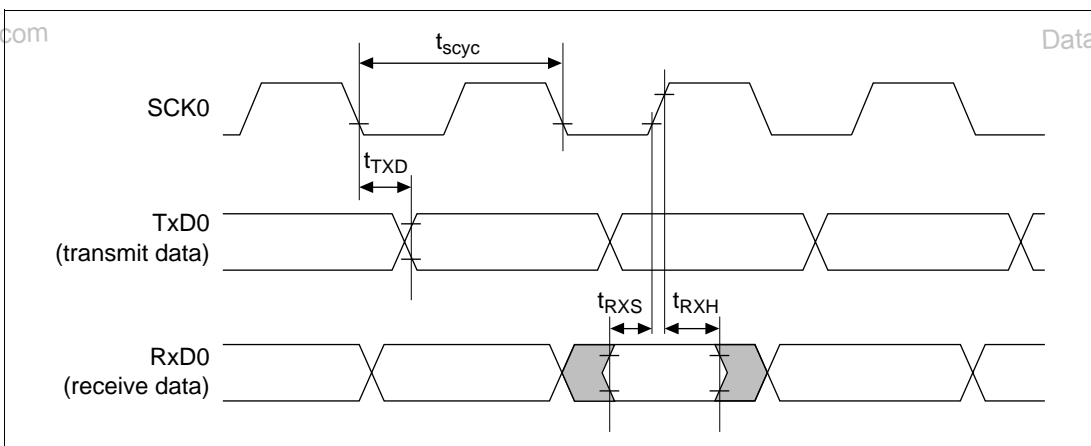
Figure 15.76 Input Clock Input/Output Timing

Figure 15.77 SCI Input/Output Timing (Clocked Synchronous Mode)

15.3.8 AC Characteristics Measurement Conditions

- I/O signal reference level: 1.5 V
- Input pulse level: V_{SS} to 3.0 V (where RES, NMI, CKIO and MD5-MD0 are within the range V_{SS} to V_{CC})
- Input rise and fall times: 1 ns

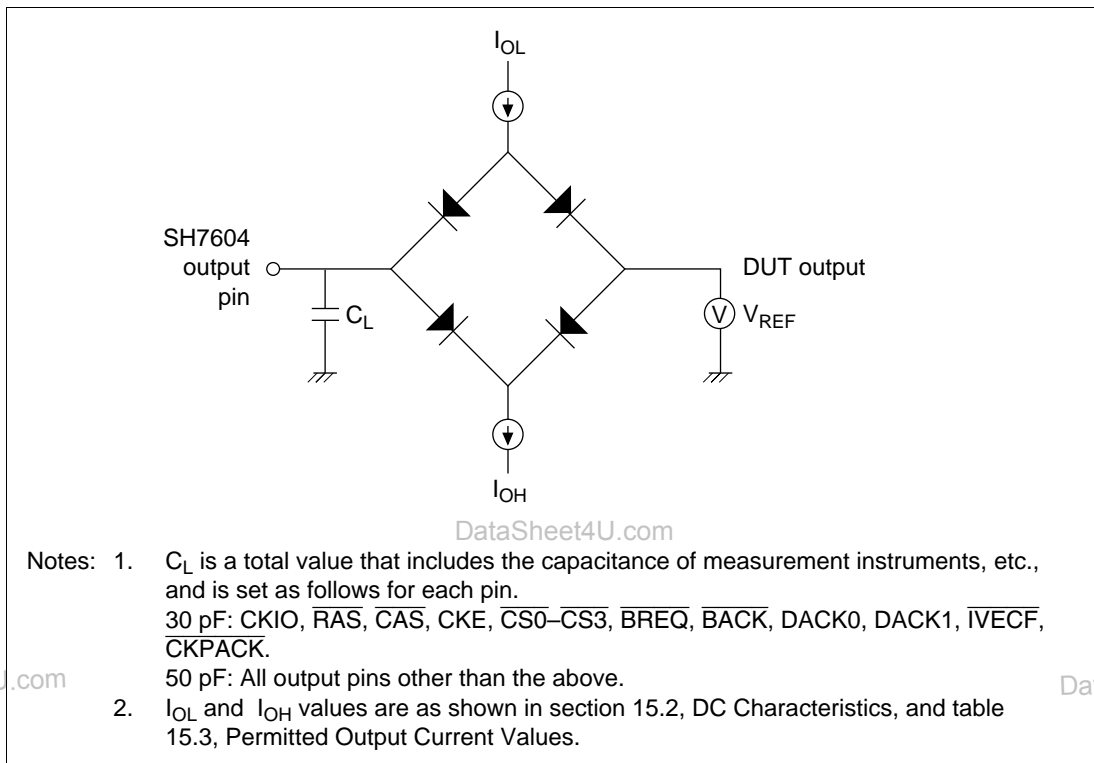

Figure 15.78 Output Load Circuit

Section 16 Electrical Characteristics (3V Version)

16.1 Absolute Maximum Ratings

Table 16.1 shows the absolute maximum ratings.

Table 16.1 Absolute Maximum Ratings

Item	Symbol	Rating	Unit
Power supply voltage	V_{CC}	-0.3 to +7.0	V
Input voltage	V_{in}	-0.3 to $V_{CC} + 0.3$	V
Operating temperature	T_{opr}	-20 to +75	°C
Storage temperature	T_{stg}	-55 to +125	°C

Caution: Operating the chip in excess of the absolute maximum rating may result in permanent damage.

DataSheet4U.com

et4U.com

DataShee

DataSheet4U.com

www.DataSheet4U.com

DataSheet4U.com

16.2 DC Characteristics

Tables 16.2 and 16.3 list DC characteristics.

Table 16.2 DC Characteristics (Conditions: $V_{CC} = 3.0$ to 5.5 V, $T_a = -20$ to $+75^\circ$ C)

Item	Symbol	Min	Typ	Max	Unit	Test Conditions	
Input high-level voltage	\overline{RES} , NMI, MD5–MD0	V_{IH}	$V_{CC} \times 0.9$	—	$V_{CC} + 0.3$	V	During standby
			$V_{CC} \times 0.9$	—	$V_{CC} + 0.3$	V	Normal operation
	EXTAL, CKIO		$V_{CC} \times 0.9$	—	$V_{CC} + 0.3$	V	
	Other input pins		$V_{CC} \times 0.7$	—	$V_{CC} + 0.3$	V	
Input low-level voltage	\overline{RES} , NMI, MD5–MD0	V_{IL}	–0.3	—	$V_{CC} \times 0.1$	V	During standby
			–0.3	—	$V_{CC} \times 0.1$	V	Normal operation
	Other input pins		–0.3	—	$V_{CC} \times 0.1$	V	
Input leak current	\overline{RES}	$ I_{in} $	—	—	1.0	μ A	$V_{in} = 0.5$ to $V_{CC} - 0.5$ V
	NMI, MD5–MD0		—	—	1.0	μ A	$V_{in} = 0.5$ to $V_{CC} - 0.5$ V
	Other input pins		—	—	1.0	μ A	$V_{in} = 0.5$ to $V_{CC} - 0.5$ V
3-state leak current (while off)	A26–A0, D31–D0, \overline{BS} , CS3–CS0, RD/ \overline{WR} , RAS, CAS, WE3–WE0, RD, IVECF	$ I_{ST} $	—	—	1.0	μ A	$V_{in} = 0.5$ to $V_{CC} - 0.5$ V
Output high-level voltage	All output pins	V_{OH}	$V_{CC} - 0.5$	—	—	V	$I_{OH} = -200$ μ A
			$V_{CC} - 1.0$	—	—	V	$I_{OH} = -1$ mA
Output low level voltage	All output pins	V_{OL}	—	—	0.4	V	$I_{OL} = 1.6$ mA
Input capacitance	\overline{RES}	C_{in}	—	—	15	pF	$V_{in} = 0$ V
	NMI		—	—	15	pF	$f = 1$ MHz
	All other input pins (including D31–D0)		—	—	15	pF	$T_a = 25^\circ$ C

Table 16.2 DC Characteristics (Conditions: $V_{CC} = 3.0$ to 5.5 V, $T_a = -20$ to $+75^\circ$ C) (cont)

Item	Symbol	Min	Typ	Max	Unit	Test Conditions
Current consumption	Normal operation	I_{CC}	—	25	30	mA $f = 8$ MHz
			—	45	55	mA $f = 16$ MHz
			—	60	70	mA $f = 28.7$ MHz
	Sleep	—	—	15	20	mA $f = 8$ MHz
			—	30	40	mA $f = 16$ MHz
			—	40	50	mA $f = 28.7$ MHz
Standby	—	—	1	5	μ A $T_a \leq 50^\circ$ C	
		—	—	20	μ A 50° C $< T_a$	

- Notes: 1. When no PLL is used, do not leave the PLLV_{CC} and PLLV_{SS} pins open. Connect PLLV_{CC} to V_{CC} and PLLV_{SS} to V_{SS}.
2. Current consumption values shown are the values at which all output pins are without load under conditions of $V_{IH\ min} = V_{CC} - 0.5$ V, $V_{IL\ max} = 0.5$ V.

Table 16.3 Permitted Output Current Values (Conditions: $V_{CC} = 5.0$ V \pm 10%, $T_a = -20$ to $+75^\circ$ C)

Item	Symbol	Min	Typ	Max	Unit
Output low-level permissible current (per pin)	I_{OL}	—	—	2.0	mA
Output low-level permissible current (total)	ΣI_{OL}	—	—	80	mA
Output high-level permissible current (per pin)	$-I_{OH}$	—	—	2.0	mA
Output high-level permissible current (total)	$\Sigma(-I_{OH})$	—	—	25	mA

Caution: To ensure chip reliability, do not exceed the output current values given in table 16.3.

16.3 AC Characteristics

16.3.1 Clock Timing

Table 16.4 Clock Timing (Conditions: $V_{CC} = 3.0$ to 0.5 V, $T_a = -20$ to $+75^\circ\text{C}$)

Item	Symbol	Min	Max	Unit	Figures
Operating frequency	f_{OP}	4	20	MHz	16.1
Clock cycle time	t_{cyc}	50	143^{*1} or 250^{*2}	ns	
Clock high pulse width	t_{CH}	8^{*1} or 15^{*2}	—	ns	
Clock low pulse width	t_{CL}	8^{*1} or 15^{*2}	—	ns	
Clock rise time	t_{CR}	—	5	ns	
Clock fall time	t_{CF}	—	5	ns	
EXTAL clock input frequency	f_{EX}	4	8	MHz	16.2
EXTAL clock input cycle time	t_{EXcyc}	125	250	ns	
EXTAL clock input low level pulse width	t_{EXL}	50	—	ns	
EXTAL clock input high level pulse width	t_{EXH}	50	—	ns	
EXTAL clock input rise time	t_{EXR}	—	5	ns	
EXTAL clock input clock fall time	t_{EXF}	—	5	ns	
Power-on oscillation settling time	t_{OSC1}	10	—	ms	16.3
Software standby oscillation settling time 1	t_{OSC2}	10	—	ms	16.4
Software standby oscillation settling time 2	t_{OSC3}	10	—	ms	16.5
PLL synchronization settling time	t_{PLL}	1	—	μs	16.6

Notes: 1. With PLL circuit 1 operating.

2. With PLL circuit 1 not used.

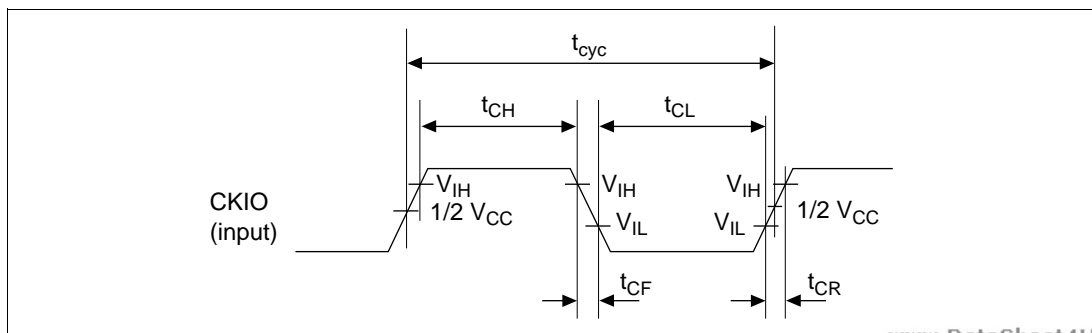
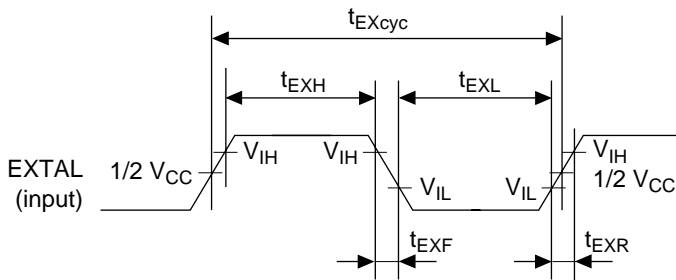
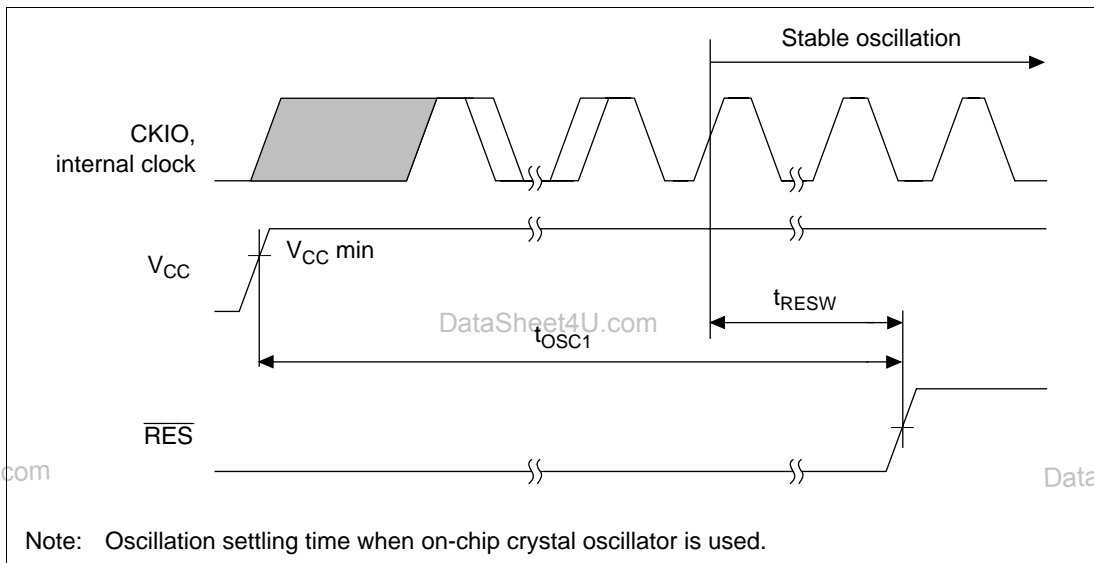

Figure 16.1 CKIO Input Timing



Note: External clock input from EXTAL pin.

Figure 16.2 EXTAL Clock Input Timing



Note: Oscillation settling time when on-chip crystal oscillator is used.

Figure 16.3 Oscillation Settling Time at Power-On

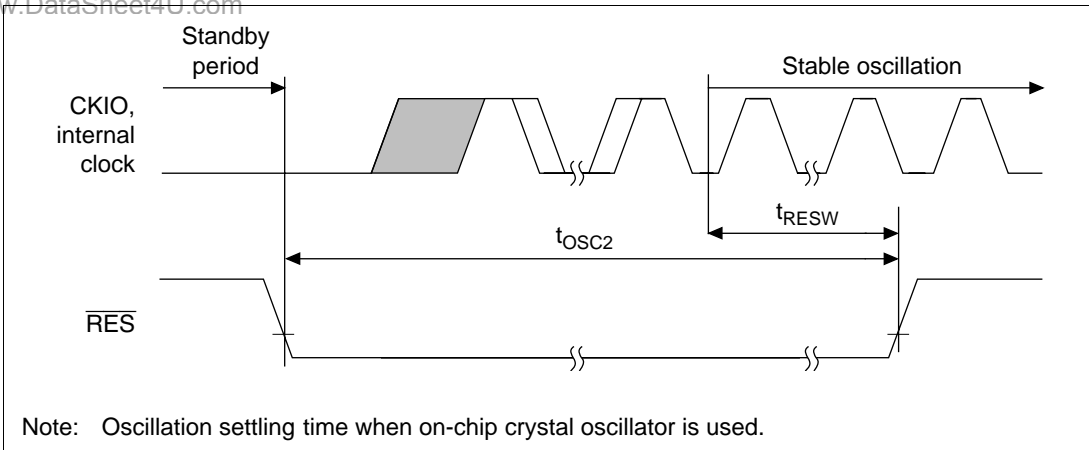

Figure 16.4 Oscillation Settling Time at Standby Return (via $\overline{\text{RES}}$)

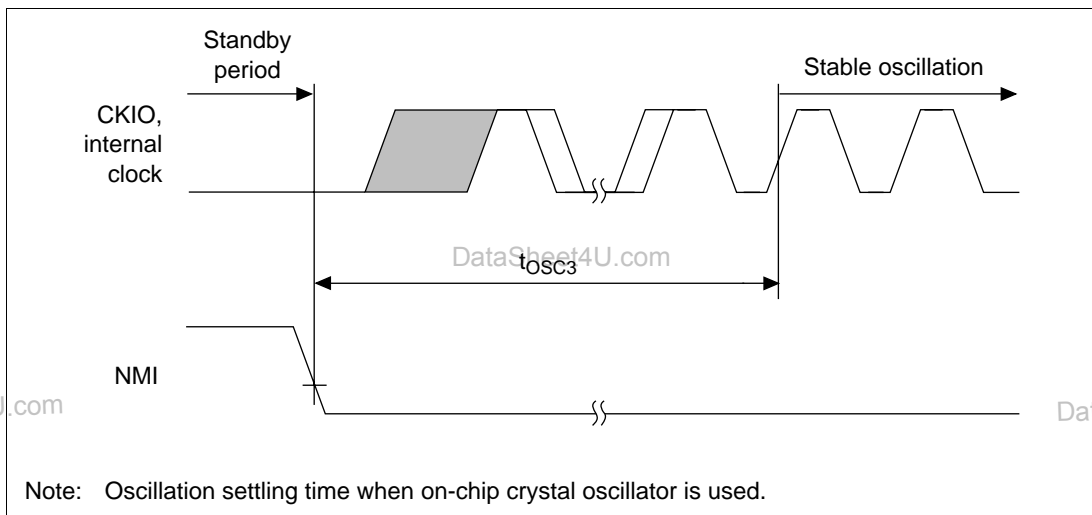

Figure 16.5 Oscillation Settling Time at Standby Return (via NMI)

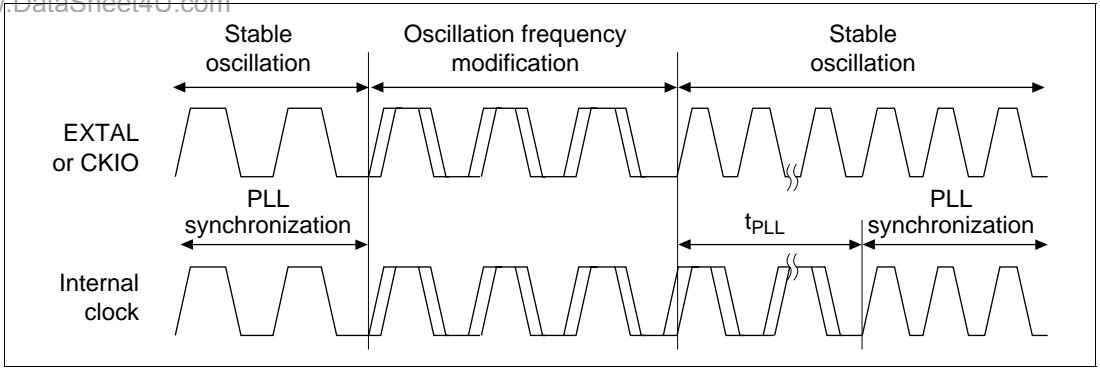

Figure 16.6 PLL Synchronization Settling Time

16.3.2 Control Signal Timing

Table 16.5 Control Signal Timing (Conditions: $V_{CC} = 3.0$ to 5.5 V, $T_a = -20$ to $+75^{\circ}\text{C}$)

Item	Symbol	Min	Max	Unit	Figure
$\overline{\text{RES}}$ rise, fall	t_{RESr} , t_{RESf}	—	200	ns	16.7
$\overline{\text{RES}}$ pulse width	t_{RESW}	20	—	t_{cyc}	
NMI reset setup time	t_{NMIRS}	$t_{\text{cyc}} + 10$	—	ns	
NMI reset hold time	t_{NMIRH}	$t_{\text{cyc}} + 10$	—	ns	
NMI rise, fall	t_{NMIr} , t_{NMIf}	—	200	ns	
NMI minimum pulse width	t_{IRQES}	3	—	t_{cyc}	
$\overline{\text{RES}}$ setup time*	t_{RESS}	40	—	ns	16.8,
NMI setup time*	t_{NMIS}	40	—	ns	16.9
$\overline{\text{IRL3}}\text{--}\overline{\text{IRL0}}$ setup time*	t_{IRLS}	40	—	ns	
$\overline{\text{RES}}$ hold time	t_{RESH}	20	—	ns	16.8,
NMI hold time	t_{NMIH}	20	—	ns	16.9
$\overline{\text{IRL3}}\text{--}\overline{\text{IRL0}}$ hold time	t_{IRLH}	20	—	ns	
$\overline{\text{BRLS}}$ setup time 1 (PLL on)	t_{BLSS1}	$1/2 t_{\text{cyc}} + 20$	—	ns	16.10
$\overline{\text{BRLS}}$ hold time 1 (PLL on)	t_{BLSH1}	$15 - 1/2 t_{\text{cyc}}$	—	ns	
$\overline{\text{BGR}}$ delay time 1 (PLL on)	t_{BGRD1}	—	$1/2 t_{\text{cyc}} + 25$	ns	
$\overline{\text{BRLS}}$ setup time 1 (PLL on, 1/4 cycle delay)	t_{BLSS1}	$1/4 t_{\text{cyc}} + 20$	—	ns	16.10
$\overline{\text{BRLS}}$ hold time 1 (PLL on, 1/4 cycle delay)	t_{BLSH1}	$15 - 1/4 t_{\text{cyc}}$	—	ns	
$\overline{\text{BGR}}$ delay time 1 (PLL on, 1/4 cycle delay)	t_{BGRD1}	—	$3/4 t_{\text{cyc}} + 25$	ns	
$\overline{\text{BRLS}}$ setup time 2 (PLL off)	t_{BLSS2}	20	—	ns	16.11
$\overline{\text{BRLS}}$ hold time 2 (PLL off)	t_{BLSH2}	30	—	ns	
$\overline{\text{BGR}}$ delay time 2 (PLL off)	t_{BGRD2}	—	40	ns	

Note: The $\overline{\text{RES}}$, NMI and $\overline{\text{IRL3}}\text{--}\overline{\text{IRL0}}$ signals are asynchronous inputs, but when the setup times shown here are observed, the signals are considered to have changed at clock fall. If the setup times are not observed, recognition may be delayed until the next clock fall.

Table 16.5 Control Signal Timing (cont)(Conditions: $V_{CC} = 3.0$ to 5.5 V, $T_a = -20$ to $+75^\circ\text{C}$)

Item	Symbol	Min	Max	Unit	Figure
$\overline{\text{BREQ}}$ delay time 1 (PLL on)	t_{BRQD1}	—	$1/2 t_{\text{cyc}} + 25$	ns	16.12
$\overline{\text{BACK}}$ setup time 1 (PLL on)	t_{BAKS1}	$1/2 t_{\text{cyc}} + 20$	—	ns	
$\overline{\text{BACK}}$ hold time 1 (PLL on)	t_{BAKH1}	$15 - 1/2 t_{\text{cyc}}$	—	ns	
$\overline{\text{BREQ}}$ delay time 1 (PLL on, 1/4 cycle delay)	t_{BRQD1}	—	$3/4 t_{\text{cyc}} + 25$	ns	16.12
$\overline{\text{BACK}}$ setup time 1 (PLL on, 1/4 cycle delay)	t_{BAKS1}	$1/4 t_{\text{cyc}} + 20$	—	ns	
$\overline{\text{BACK}}$ hold time 1 (PLL on, 1/4 cycle delay)	t_{BAKH1}	$15 - 1/4 t_{\text{cyc}}$	—	ns	
$\overline{\text{BREQ}}$ delay time 2 (PLL off)	t_{BRQD2}	—	40	ns	16.13
$\overline{\text{BACK}}$ setup time 2 (PLL off)	t_{BAKS2}	20	—	ns	
$\overline{\text{BACK}}$ hold time 2 (PLL off)	t_{BAKH2}	30	—	ns	
Bus tri-state delay time 1 (PLL on)	t_{BOFF1}	0	35	ns	16.10,
Bus buffer on time 1 (PLL on)	t_{BON1}	0	33	ns	16.12
Bus tri-state delay time 1 (PLL on, 1/4 cycle delay)	t_{BOFF1}	$1/4 t_{\text{cyc}}$	$1/4 t_{\text{cyc}} + 35$	ns	16.10,
Bus buffer on time 1 (PLL on, 1/4 cycle delay)	t_{BON1}	$1/4 t_{\text{cyc}}$	$1/4 t_{\text{cyc}} + 33$	ns	16.12
Bus tri-state delay time 1 (PLL off)	t_{BOFF1}	0	45	ns	16.11,
Bus buffer on time 1 (PLL off)	t_{BON1}	0	40	ns	16.13
Bus tri-state delay time 2 (PLL on)	t_{BOFF2}	$1/2 t_{\text{cyc}}$	$1/2 t_{\text{cyc}} + 35$	ns	16.10,
Bus buffer on time 2 (PLL on)	t_{BON2}	$1/2 t_{\text{cyc}}$	$1/2 t_{\text{cyc}} + 33$	ns	16.12
Bus tri-state delay time 2 (PLL on, 1/4 cycle delay)	t_{BOFF2}	$3/4 t_{\text{cyc}}$	$3/4 t_{\text{cyc}} + 35$	ns	16.10,
Bus buffer on time 2 (PLL on, 1/4 cycle delay)	t_{BON2}	$3/4 t_{\text{cyc}}$	$3/4 t_{\text{cyc}} + 33$	ns	16.12
Bus tri-state delay time 3 (PLL off)	t_{BOFF3}	0	45	ns	16.11,
Bus buffer on time 3 (PLL off)	t_{BON3}	0	40	ns	16.13

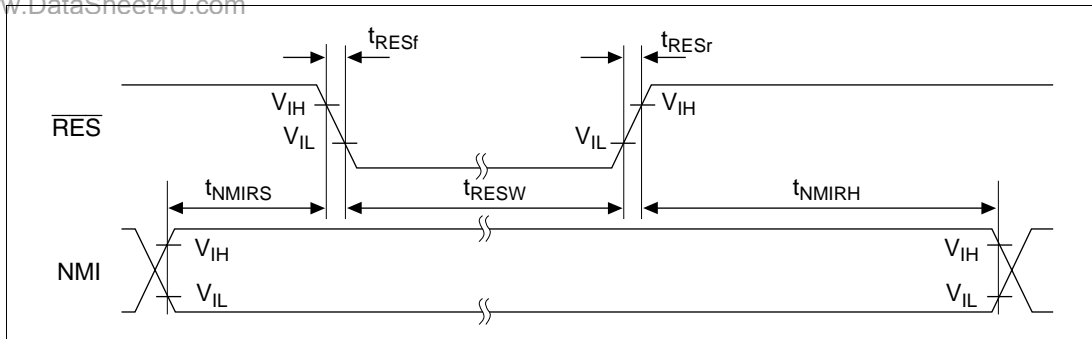

Figure 16.7 Reset Input Timing

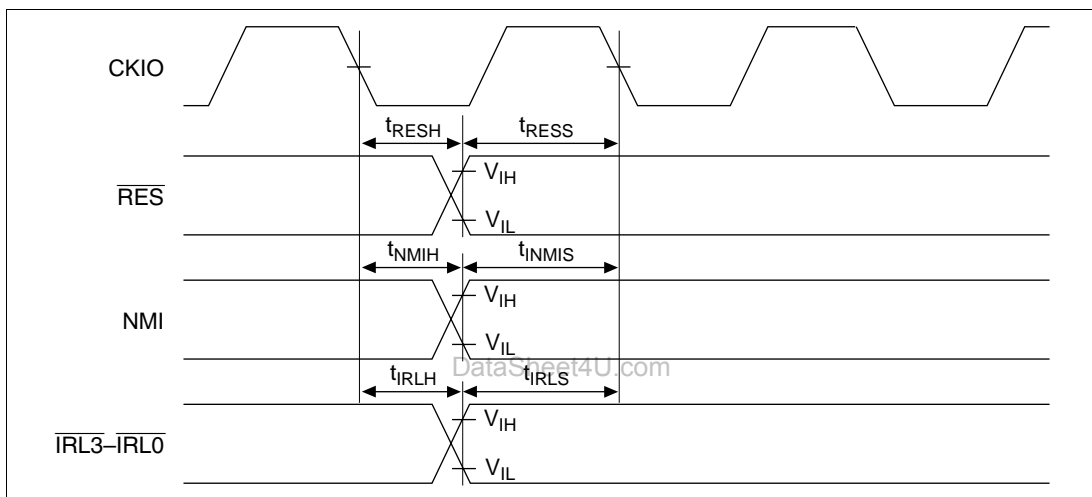

Figure 16.8 Interrupt Signal Input Timing (PLL1 Off)

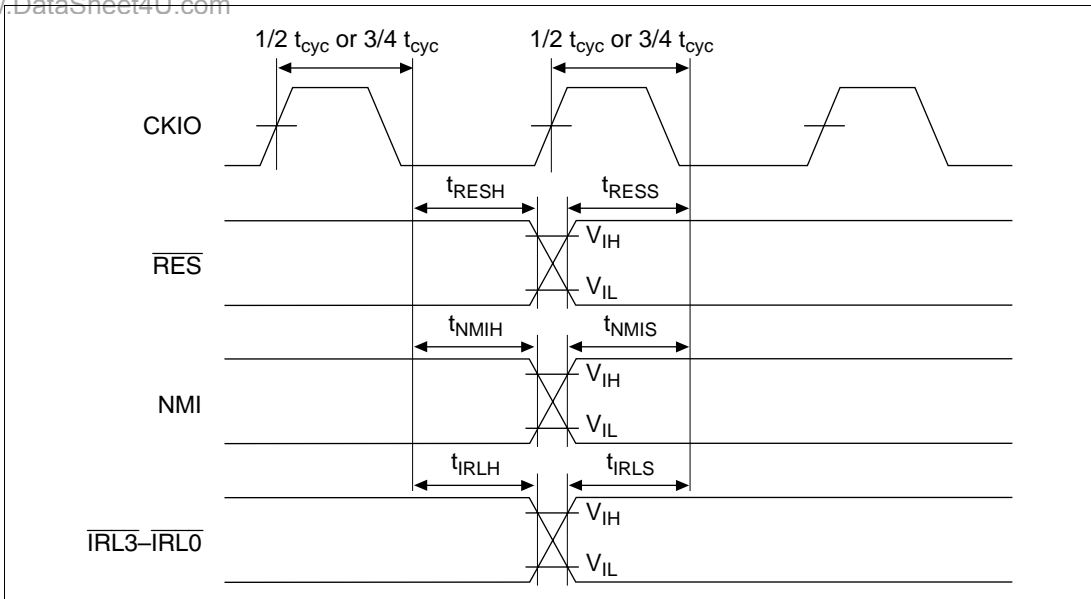

Figure 16.9 Interrupt Signal Input Timing (PLL1 On)

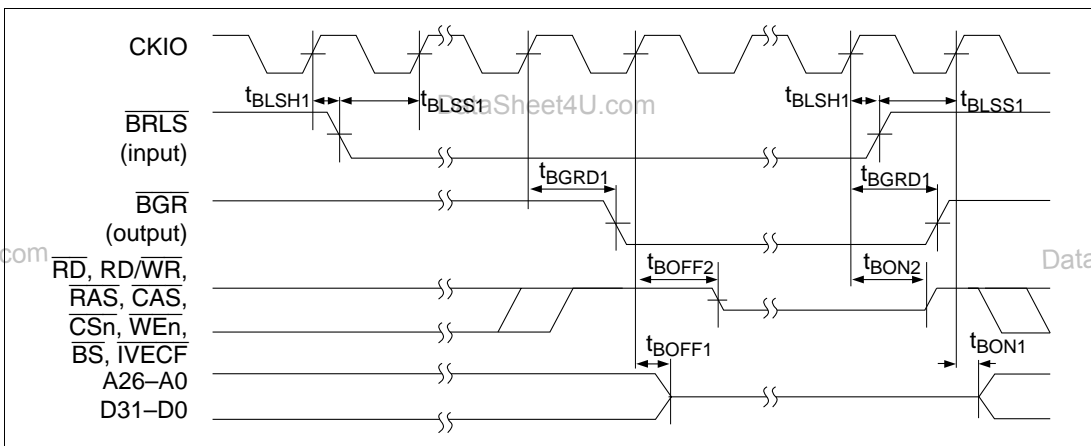

Figure 16.10 Bus Release Timing (Master Mode, PLL1 On)

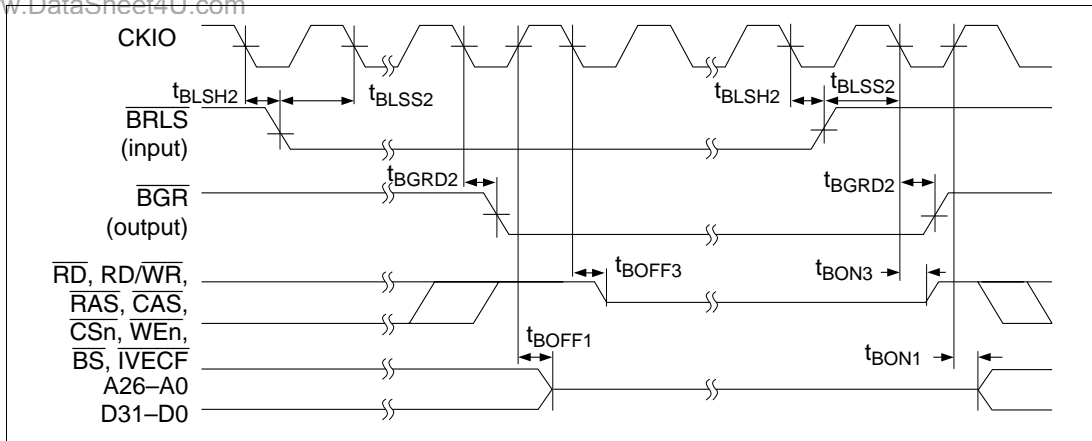

Figure 16.11 Bus Release Timing (Master Mode, PLL1 Off)

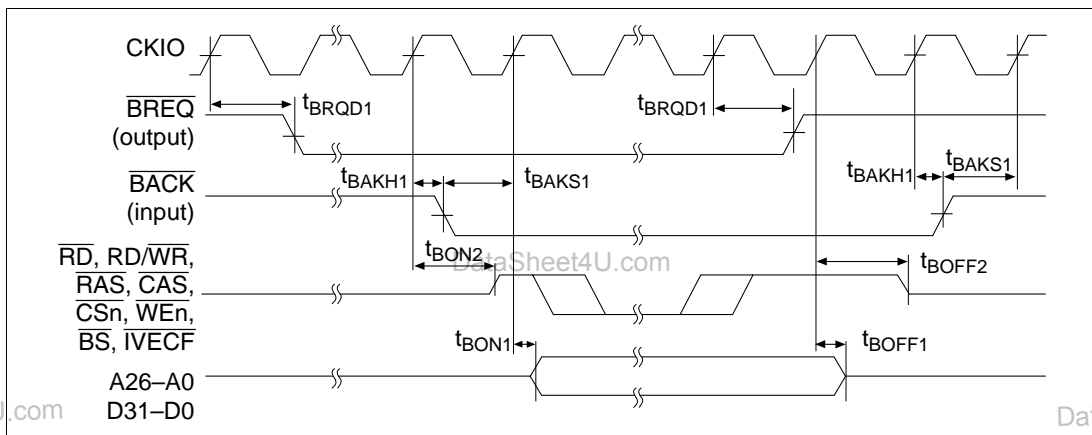

Figure 16.12 Bus Release Timing (Slave Mode, PLL1 On)

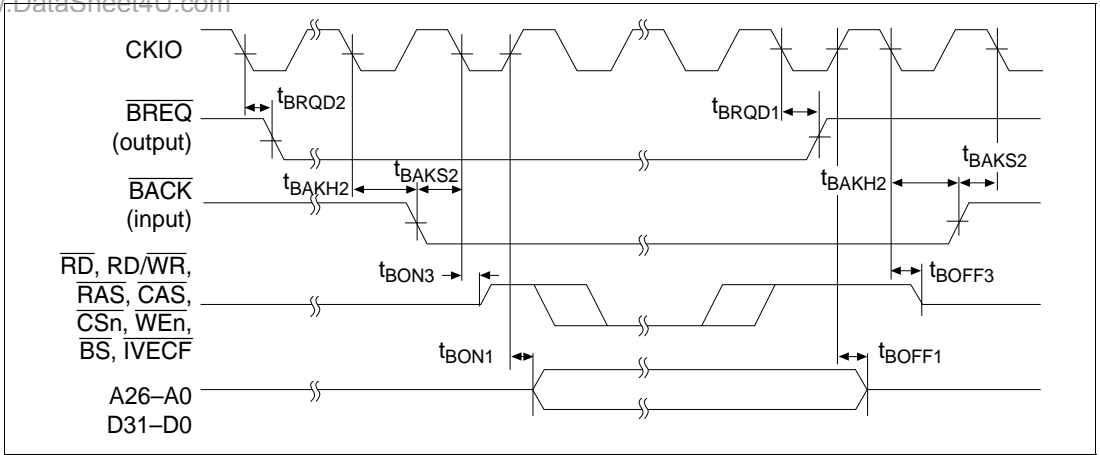

Figure 16.13 Bus Release Timing (Slave Mode, PLL1 Off)

DataSheet4U.com

et4U.com

DataShee

DataSheet4U.com

www.DataSheet4U.com

DataSheet4U.com

Table 16.6 Bus Timing With PLL On [Mode 0, 4]
 (Conditions: $V_{CC} = 3.0$ to 5.5 V, $T_a = -20$ to $+75^\circ\text{C}$)

Item	Symbol	Min	Max	Unit	Figures
Address delay time	t_{AD}	—	28	ns	16.14, 16.20, 16.40, 16.52, 16.66, 16.68
\overline{BS} delay time	t_{BSD}	—	25	ns	16.14, 16.20, 16.40, 16.52, 16.66
\overline{CS} delay time 1	t_{CSD1}	—	25	ns	16.14, 16.20, 16.40, 16.52, 16.66
\overline{CS} delay time 2	t_{CSD2}	—	$1/2 t_{cyc} + 25$	ns	16.14, 16.66
Read/write delay time	t_{RWD}	—	25	ns	16.14, 16.20, 16.40, 16.52, 16.66
Read strobe delay time 1	t_{RSD1}	—	$1/2 t_{cyc} + 25$	ns	16.14, 16.40, 16.52, 16.66, 16.68
Read data setup time 1	t_{RDS1}	$1/2 t_{cyc} + 10$	—	ns	16.14, 16.40, 16.52, 16.66, 16.68
Read data setup time 3 (SDRAM)	t_{RDS3}	$1/2 t_{cyc} + 10$	—	ns	16.20
Read data hold time 2	t_{RDH2}	0	—	ns	16.14, 16.66
Read data hold time 4 (SDRAM)	t_{RDH4}	0	—	ns	16.20
Read data hold time 5 (DRAM)	t_{RDH5}	0	—	ns	16.40
Read data hold time 6 (PSRAM)	t_{RDH6}	0	—	ns	16.52
Read data hold time 7 (interrupt vector)	t_{RDH7}	0	—	ns	16.68
Write enable delay time	t_{WED1}	$1/2 t_{cyc} + 3$	$1/2 t_{cyc} + 25$	ns	16.14, 16.15, 16.52, 16.53
Write data delay time 1	t_{WDD}	—	25	ns	16.15, 16.27, 16.41, 16.53
Write data hold time 1	t_{WDH1}	3	—	ns	16.15, 16.27, 16.41, 16.53
Data buffer on time	t_{DON}	—	25	ns	16.15, 16.27, 16.41, 16.53
Data buffer off time	t_{DOF}	—	25	ns	16.15, 16.27, 16.41, 16.53

Table 16.6 Bus Timing With PLL On [Mode 0, 4] (cont)(Conditions: $V_{CC} = 3.0$ to 5.5 V, $T_a = -20$ to $+75^\circ\text{C}$)

Item	Symbol	Min	Max	Unit	Figures
DACK delay time 1	t_{DACD1}	—	25	ns	16.14, 16.20, 16.40, 16.52, 16.66
DACK delay time 2	t_{DACD2}	—	$1/2 t_{cyc} + 25$	ns	16.14, 16.20, 16.40, 16.52, 16.66
$\overline{\text{WAIT}}$ setup time	t_{WTS}	20	—	ns	16.19, 16.43, 16.55, 16.66, 16.70
$\overline{\text{WAIT}}$ hold time	t_{WTH}	10	—	ns	16.19, 16.43, 16.55, 16.66, 16.70
$\overline{\text{RAS}}$ delay time 1 (SDRAM)	t_{RASD1}	—	25	ns	16.20
$\overline{\text{RAS}}$ delay time 2 (DRAM)	t_{RASD2}	$1/2 t_{cyc} + 3$	$1/2 t_{cyc} + 25$	ns	16.40
$\overline{\text{CAS}}$ delay time 1 (SDRAM)	t_{CASD1}	—	25	ns	16.20
$\overline{\text{CAS}}$ delay time 2 (DRAM)	t_{CASD2}	$1/2 t_{cyc} + 3$	$1/2 t_{cyc} + 25$	ns	16.40
DQM delay time	t_{DQMD}	—	25	ns	16.20
CKE delay time	t_{CKED}	—	33	ns	16.37
$\overline{\text{CE}}$ delay time 1	t_{CED1}	$1/2 t_{cyc} + 3$	$1/2 t_{cyc} + 25$	ns	16.52
$\overline{\text{OE}}$ delay time 1	t_{OED1}	—	$1/2 t_{cyc} + 25$	ns	16.52
$\overline{\text{IVECF}}$ delay time	t_{IVD}	—	25	ns	16.68
Address input setup time	t_{ASIN}	25	—	ns	16.71
Address input hold time	t_{AHIN}	10	—	ns	16.71
$\overline{\text{BS}}$ input setup time	t_{BSS}	25	—	ns	16.71
$\overline{\text{BS}}$ input hold time	t_{BSH}	10	—	ns	16.71
Read/write input setup time	t_{RWS}	25	—	ns	16.71
Read/write input hold time	t_{RWH}	10	—	ns	16.71

Table 16.7 Bus Timing With PLL On and 1/4 Cycle Delay [Mode 1, 5]**(Conditions: $V_{CC} = 3.0$ to 5.5 V, $T_a = -20$ to $+75^{\circ}\text{C}$)**

Item	Symbol	Min	Max	Unit	Figures
Address delay time	t_{AD}	—	$1/4 t_{cyc} + 28$	ns	16.14, 16.20, 16.40, 16.52, 16.66, 16.68
\overline{BS} delay time	t_{BSD}	—	$1/4 t_{cyc} + 25$	ns	16.14, 16.20, 16.40, 16.52, 16.66
\overline{CS} delay time 1	t_{CSD1}	—	$1/4 t_{cyc} + 25$	ns	16.14, 16.20, 16.40, 16.52, 16.66
\overline{CS} delay time 2	t_{CSD2}	—	$3/4 t_{cyc} + 25$	ns	16.14, 16.66
Read/write delay time	t_{RWD}	—	$1/4 t_{cyc} + 25$	ns	16.14, 16.20, 16.40, 16.52, 16.66
Read strobe delay time 1	t_{RSD1}	—	$3/4 t_{cyc} + 25$	ns	16.14, 16.40, 16.52, 16.66, 16.68
Read data setup time 1	t_{RDS1}	$1/4 t_{cyc} + 10$	—	ns	16.14, 16.40, 16.52, 16.66, 16.68
Read data setup time 3 (SDRAM)	t_{RDS3}	$1/4 t_{cyc} + 10$	—	ns	16.20
Read data hold time 2	t_{RDH2}	0	—	ns	16.14, 16.66
Read data hold time 4 (SDRAM)	t_{RDH4}	0	—	ns	16.20
Read data hold time 5 (DRAM)	t_{RDH5}	0	—	ns	16.40
Read data hold time 6 (PSRAM)	t_{RDH6}	0	—	ns	16.52
Read data hold time 7 (interrupt vector)	t_{RDH7}	0	—	ns	16.68
Write enable delay time	t_{WED1}	$3/4 t_{cyc} + 3$	$3/4 t_{cyc} + 25$	ns	16.14, 16.15, 16.52, 16.53
Write data delay time 1	t_{WDD}	—	$1/4 t_{cyc} + 25$	ns	16.15, 16.27, 16.41, 16.53
Write data hold time 1	t_{WDH1}	$1/4 t_{cyc} + 3$	—	ns	16.15, 16.27, 16.41, 16.53
Data buffer on time	t_{DON}	—	$1/4 t_{cyc} + 25$	ns	16.15, 16.27, 16.41, 16.53
Data buffer off time	t_{DOF}	—	$1/4 t_{cyc} + 25$	ns	16.15, 16.27, 16.41, 16.53

Table 16.7 Bus Timing With PLL On and 1/4 Cycle Delay [Mode 1, 5] (cont)
 (Conditions: $V_{CC} = 3.0$ to 5.5 V, $T_a = -20$ to $+75^\circ\text{C}$)

Item	Symbol	Min	Max	Unit	Figures
DACK delay time 1	t_{DACD1}	—	$1/4 t_{cyc} + 25$	ns	16.14, 16.20, 16.40, 16.52, 16.66
DACK delay time 2	t_{DACD2}	—	$3/4 t_{cyc} + 25$	ns	16.14, 16.20, 16.40, 16.52, 16.66
$\overline{\text{WAIT}}$ setup time	t_{WTS}	$20 - 1/4 t_{cyc}$	—	ns	16.19, 16.43, 16.55, 16.66, 16.70
$\overline{\text{WAIT}}$ hold time	t_{WTH}	$1/4 t_{cyc} + 10$	—	ns	16.19, 16.43, 16.55, 16.66, 16.70
$\overline{\text{RAS}}$ delay time 1 (SDRAM)	t_{RASD1}	—	$1/4 t_{cyc} + 25$	ns	16.20
$\overline{\text{RAS}}$ delay time 2 (DRAM)	t_{RASD2}	$3/4 t_{cyc} + 3$	$3/4 t_{cyc} + 25$	ns	16.40
$\overline{\text{CAS}}$ delay time 1 (SDRAM)	t_{CASD1}	—	$1/4 t_{cyc} + 25$	ns	16.20
$\overline{\text{CAS}}$ delay time 2 (DRAM)	t_{CASD2}	$3/4 t_{cyc} + 3$	$3/4 t_{cyc} + 25$	ns	16.40
DQM delay time	t_{DQMD}	—	$1/4 t_{cyc} + 25$	ns	16.20
CKE delay time	t_{CKED}	—	$1/4 t_{cyc} + 33$	ns	16.37
$\overline{\text{CE}}$ delay time 1	t_{CED1}	$3/4 t_{cyc} + 3$	$3/4 t_{cyc} + 25$	ns	16.52
$\overline{\text{OE}}$ delay time 1	t_{OED1}	—	$3/4 t_{cyc} + 25$	ns	16.52
$\overline{\text{IVECF}}$ delay time	t_{IVD}	—	$1/4 t_{cyc} + 25$	ns	16.68
Address input setup time	t_{ASIN}	$25 - 1/4 t_{cyc}$	—	ns	16.71
Address input hold time	t_{AHIN}	$1/4 t_{cyc} + 10$	—	ns	16.71
$\overline{\text{BS}}$ input setup time	t_{BSS}	$25 - 1/4 t_{cyc}$	—	ns	16.71
$\overline{\text{BS}}$ input hold time	t_{BSH}	$1/4 t_{cyc} + 10$	—	ns	16.71
Read/write input setup time	t_{RWS}	$25 - 1/4 t_{cyc}$	—	ns	16.71
Read/write input hold time	t_{RWH}	$1/4 t_{cyc} + 10$	—	ns	16.71

Table 16.8 Bus Timing With PLL Off (CKIO Input) [Mode 6]
 (Conditions: $V_{CC} = 3.0$ to 5.5 V, $T_a = -20$ to $+75^\circ\text{C}$)

Item	Symbol	Min	Max	Unit	Figures
Address delay time	t_{AD}	—	43	ns	16.16, 16.38, 16.47, 16.60, 16.67, 16.69
\overline{BS} delay time	t_{BSD}	—	40	ns	16.16, 16.38, 16.47, 16.60, 16.67
\overline{CS} delay time 1	t_{CSD1}	—	40	ns	16.16, 16.38, 16.47, 16.60, 16.67
\overline{CS} delay time 3	t_{CSD3}	—	40	ns	16.16, 16.67
Read write delay time	t_{RWD}	—	40	ns	16.16, 16.38, 16.47, 16.60, 16.67
Read strobe delay time 2	t_{RSD2}	—	40	ns	16.16, 16.47, 16.60, 16.67, 16.69
Read data setup time 2	t_{RDS2}	10	—	ns	16.16, 16.38, 16.47, 16.60, 16.67, 16.69
Read data hold time 2	t_{RDH2}	0	—	ns	16.16, 16.67
Read data hold time 3	t_{RDH3}	30	—	ns	16.38
Read data hold time 5 (DRAM)	t_{RDH5}	0	—	ns	16.47
Read data hold time 6 (PSRAM)	t_{RDH6}	0	—	ns	16.60
Read data hold time 7 (interrupt vector)	t_{RDH7}	0	—	ns	16.69
Write enable delay time 2	t_{WED2}	—	40	ns	16.17, 16.61
Write data delay time	t_{WDD}	—	40	ns	16.17, 16.39, 16.48, 16.61
Write data hold time 1	t_{WDH1}	3	—	ns	16.17, 16.39, 16.48, 16.61
Write data hold time 2	t_{WDH2}	5	—	ns	16.17
Write data hold time 3	t_{WDH3}	3	—	ns	16.61
DACK delay time 1	t_{DACD1}	—	40	ns	16.16, 16.38, 16.47, 16.60, 16.67
DACK delay time 3	t_{DACD3}	—	40	ns	16.16, 16.38, 16.47, 16.60, 16.67

Table 16.8 Bus Timing With PLL Off (CKIO Input) [Mode 6] (cont)
 (Conditions: $V_{CC} = 3.0$ to 5.5 V, $T_a = -20$ to $+75^\circ\text{C}$)

Item	Symbol	Min	Max	Unit	Figures
WAIT setup time	t_{WTS}	20	—	ns	16.19, 16.43, 16.55, 16.67, 16.70
WAIT hold time	t_{WTH}	25	—	ns	16.19, 16.43, 16.55, 16.67, 16.70
$\overline{\text{RAS}}$ delay time 1 (SDRAM)	t_{RASD1}	—	40	ns	16.38
$\overline{\text{RAS}}$ delay time 3 (DRAM)	t_{RASD3}	—	40	ns	16.47
$\overline{\text{CAS}}$ delay time 1 (SDRAM)	t_{CASD1}	—	40	ns	16.38
$\overline{\text{CAS}}$ delay time 3 (DRAM)	t_{CASD3}	—	40	ns	16.47
DQM delay time	t_{DQMD}	—	40	ns	16.38
CKE delay time	t_{CKED}	—	48	ns	16.37
$\overline{\text{CE}}$ delay time 2	t_{CED2}	—	40	ns	16.60
$\overline{\text{OE}}$ delay time 2	t_{OED2}	—	40	ns	16.60
$\overline{\text{IVECF}}$ delay time	t_{IVD}	—	40	ns	16.69
$\overline{\text{WE}}$ setup time	t_{WES1}	0	—	ns	16.16
Address setup time 1	t_{AS1}	0	—	ns	16.17
Address setup time 2	t_{AS2}	3	—	ns	16.60
Address hold time 2	t_{AH2}	0	—	ns	16.17
Row address setup time	t_{ASR}	3	—	ns	16.47
Column address setup time	t_{ASC}	3	—	ns	16.47
Write command setup time	t_{WCS}	3	—	ns	16.48
Write data setup time	t_{WDS}	3	—	ns	16.48
Address input setup time*	t_{ASIN}	20	—	ns	16.71
Address input hold time*	t_{AHIN}	25	—	ns	16.71
$\overline{\text{BS}}$ input setup time*	t_{BSS}	20	—	ns	16.71
$\overline{\text{BS}}$ input hold time*	t_{BSH}	25	—	ns	16.71
Read/write input setup time*	t_{RWS}	20	—	ns	16.71
Read/write input hold time*	t_{RWH}	25	—	ns	16.71
Data buffer on time	t_{DON}	—	40	ns	16.17, 16.39, 16.48, 16.61
Data buffer off time	t_{DOF}	—	40	ns	16.17, 16.39, 16.48, 16.61

Note: When the external addresses monitor function is used, the PLL must be on.

Table 16.9 Bus Timing With PLL Off (CKIO Output) [Mode 2](Conditions: $V_{CC} = 3.0$ to 5.5 V, $T_a = -20$ to $+75^{\circ}\text{C}$)

Item	Symbol	Min	Max	Unit	Figures
Address delay time	t_{AD}	—	28	ns	16.16, 16.38, 16.47, 16.60, 16.67, 16.69
\overline{BS} delay time	t_{BSD}	—	25	ns	16.16, 16.38, 16.47, 16.60, 16.67
\overline{CS} delay time 1	t_{CSD1}	—	25	ns	16.16, 16.38, 16.47, 16.60, 16.67
\overline{CS} delay time 3	t_{CSD3}	—	25	ns	16.16, 16.67
Read write delay time	t_{RWD}	—	25	ns	16.16, 16.38, 16.47, 16.60, 16.67
Read strobe delay time 2	t_{RSD2}	—	25	ns	16.16, 16.47, 16.60, 16.67, 16.69
Read data setup time 2	t_{RDS2}	10	—	ns	16.16, 16.38, 16.47, 16.60, 16.67, 16.69
Read data hold time 2	t_{RDH2}	0	—	ns	16.16, 16.67
Read data hold time 3 (SDRAM)	t_{RDH3}	$1/2 t_{cyc}$	—	ns	16.38
Read data hold time 5 (DRAM)	t_{RDH5}	0	—	ns	16.47
Read data hold time 6 (PSRAM)	t_{RDH6}	0	—	ns	16.60
Read data hold time 7 (interrupt vector)	t_{RDH7}	0	—	ns	16.69
Write enable delay time 2	t_{WED2}	3	25	ns	16.17, 16.61
Write data delay time	t_{WDD}	—	25	ns	16.17, 16.39, 16.48, 16.61
Write data hold time 1	t_{WDH1}	3	—	ns	16.17, 16.39, 16.48, 16.61
Write data hold time 2	t_{WDH2}	5	—	ns	16.17
Write data hold time 3	t_{WDH3}	3	—	ns	16.61
DACK delay time 1	t_{DACD1}	—	25	ns	16.16, 16.38, 16.47, 16.60, 16.67
DACK delay time 3	t_{DACD3}	—	25	ns	16.16, 16.38, 16.47, 16.60, 16.67

Table 16.9 Bus Timing With PLL Off (CKIO Output) [Mode 2] (cont)**(Conditions: $V_{CC} = 3.0$ to 5.5 V, $T_a = -20$ to $+75^{\circ}\text{C}$)**

Item	Symbol	Min	Max	Unit	Figures
WAIT setup time	t_{WTS}	20	—	ns	16.19, 16.43, 16.55, 16.67, 16.70
WAIT hold time	t_{WTH}	10	—	ns	16.19, 16.43, 16.55, 16.67, 16.70
$\overline{\text{RAS}}$ delay time 1 (SDRAM)	t_{RASD1}	—	25	ns	16.38
$\overline{\text{RAS}}$ delay time 3 (DRAM)	t_{RASD3}	3	25	ns	16.47
$\overline{\text{CAS}}$ delay time 1 (SDRAM)	t_{CASD1}	—	25	ns	16.38
$\overline{\text{CAS}}$ delay time 3 (DRAM)	t_{CASD3}	3	25	ns	16.47
DQM delay time	t_{DQMD}	—	25	ns	16.38
CKE delay time	t_{CKED}	—	33	ns	16.37
$\overline{\text{CE}}$ delay time 2	t_{CED2}	3	25	ns	16.60
$\overline{\text{OE}}$ delay time 2	t_{OED2}	—	25	ns	16.60
$\overline{\text{IVECF}}$ delay time	t_{IVD}	—	25	ns	16.69
Address input setup time*	t_{ASIN}	25	—	ns	16.71
Address input hold time*	t_{AHIN}	10	—	ns	16.71
$\overline{\text{BS}}$ input setup time*	t_{BSS}	25	—	ns	16.71
$\overline{\text{BS}}$ input hold time*	t_{BSH}	10	—	ns	16.71
Read/write input setup time*	t_{RWS}	25	—	ns	16.71
Read/write input hold time*	t_{RWH}	10	—	ns	16.71
Data buffer on time	t_{DON}	—	25	ns	16.17, 16.39, 16.48, 16.61
Data buffer off time	t_{DOF}	—	25	ns	16.17, 16.39, 16.48, 16.61

Note: When the external addresses monitor function is used, the PLL must be on.

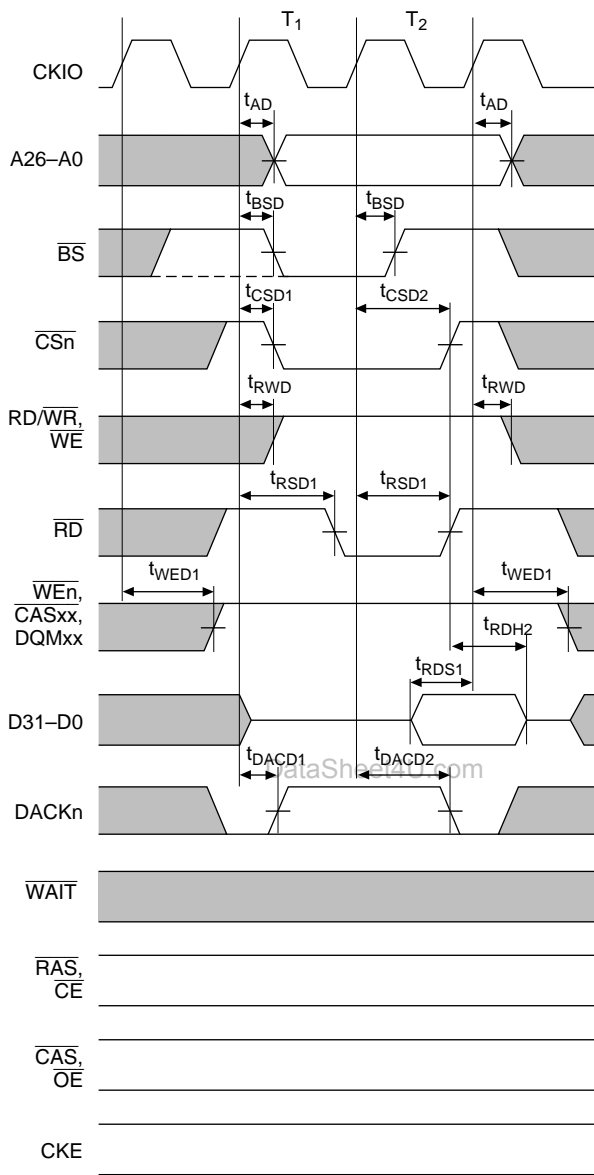

- Notes:
1. The dotted line shows the waveform when synchronous DRAM is connected.
 2. t_{RDH2} is specified from the rise of \overline{CS}_n or \overline{RD} , whichever is first.
 3. The DACK_n waveform shown is for the case where active-high has been specified.

Figure 16.14 Basic Read Cycle (No Waits, PLL On)

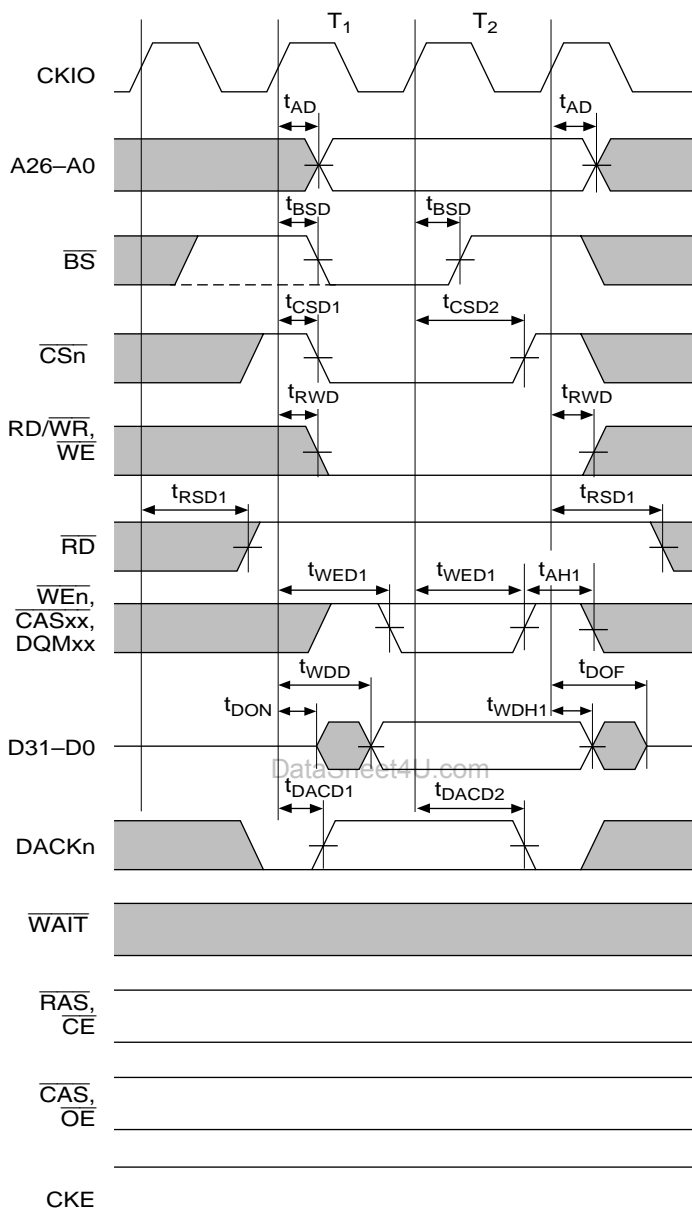

- Notes: 1. The dotted line shows the waveform when synchronous DRAM is connected.
 2. The DACK_n waveform shown is for the case where active-high has been specified.

Figure 16.15 Basic Write Cycle (No Waits, PLL On)

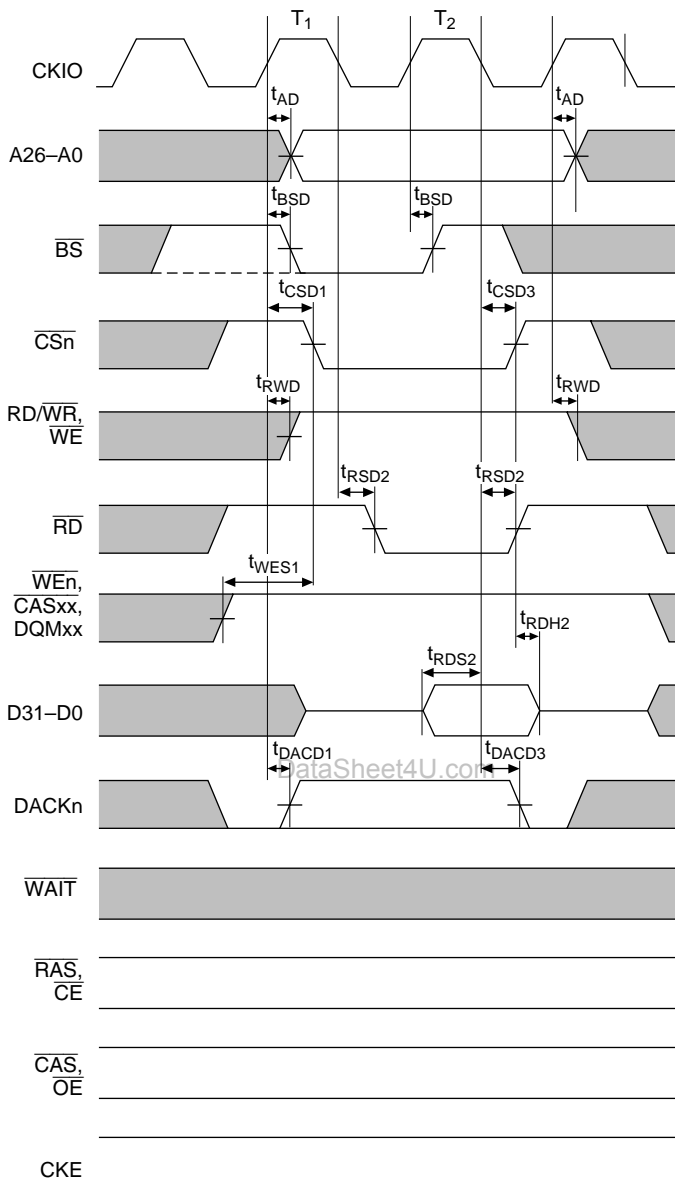

- Notes:
1. The dotted line shows the waveform when synchronous DRAM is connected.
 2. t_{RDH2} is specified from the rise of \overline{CSn} or \overline{RD} , whichever is first.
 3. The \overline{DACKn} waveform shown is for the case where active-high has been specified.

Figure 16.16 Basic Read Cycle (No Waits, PLL Off)

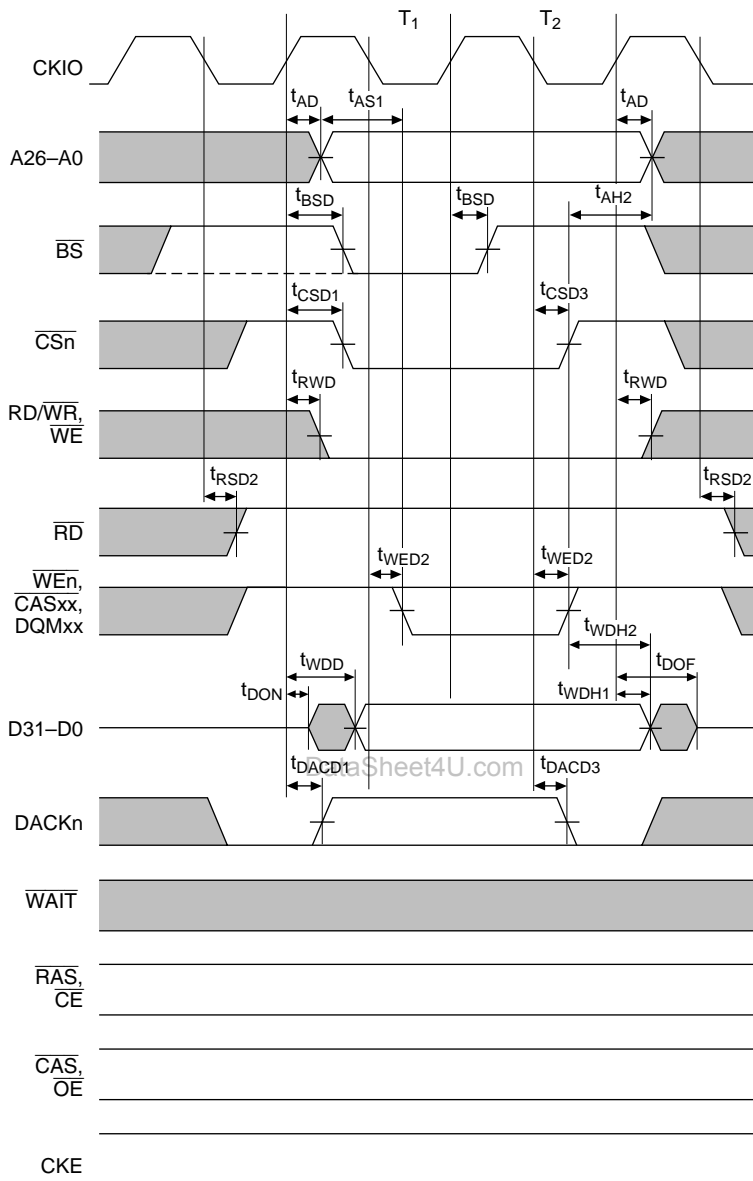

- Notes: 1. The dotted line shows the waveform when synchronous DRAM is connected.
 2. The DACKn waveform shown is for the case where active-high has been specified.

Figure 16.17 Basic Write Cycle (No Waits, PLL Off)

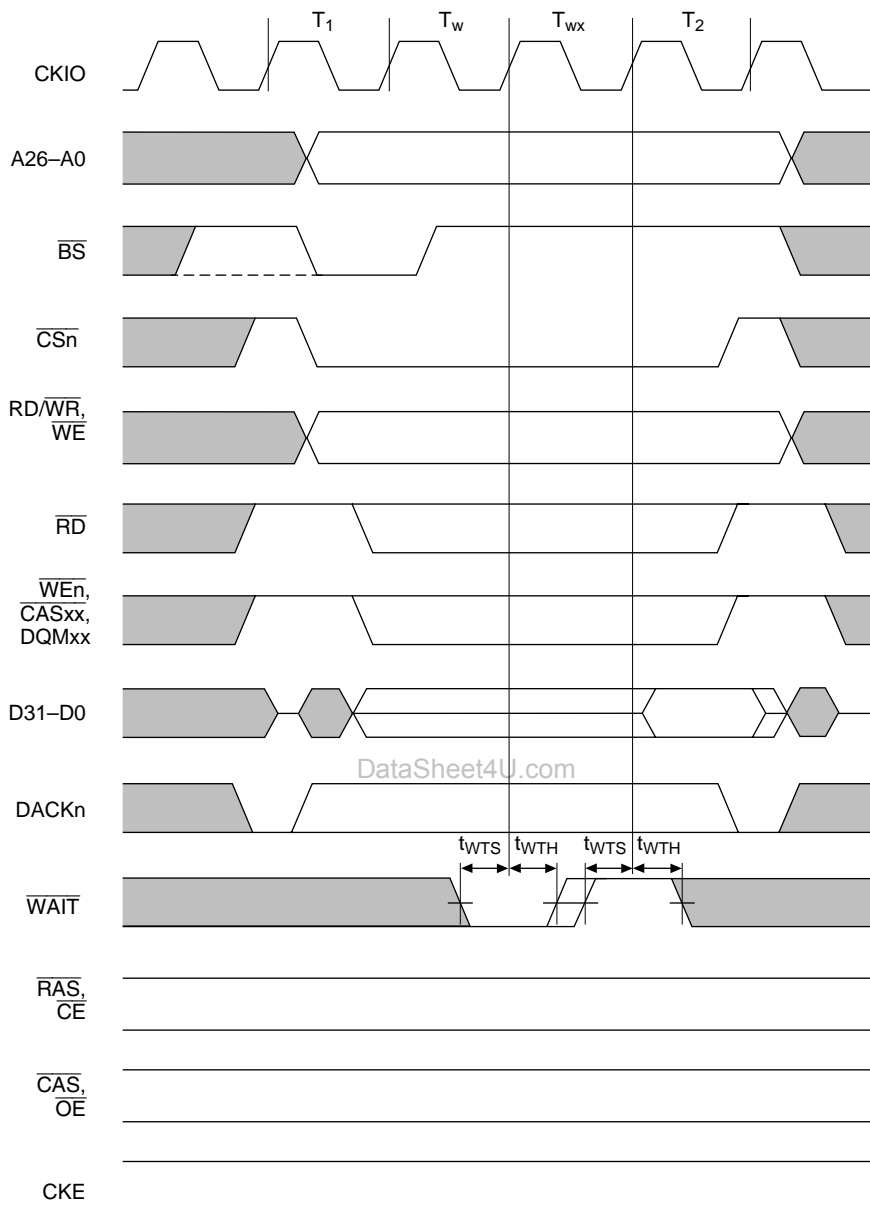

- Notes: 1. The dotted line shows the waveform when synchronous DRAM is connected.
 2. The DACKn waveform shown is for the case where active-high has been specified.

Figure 16.19 Basic Bus Cycle (External Wait Input)

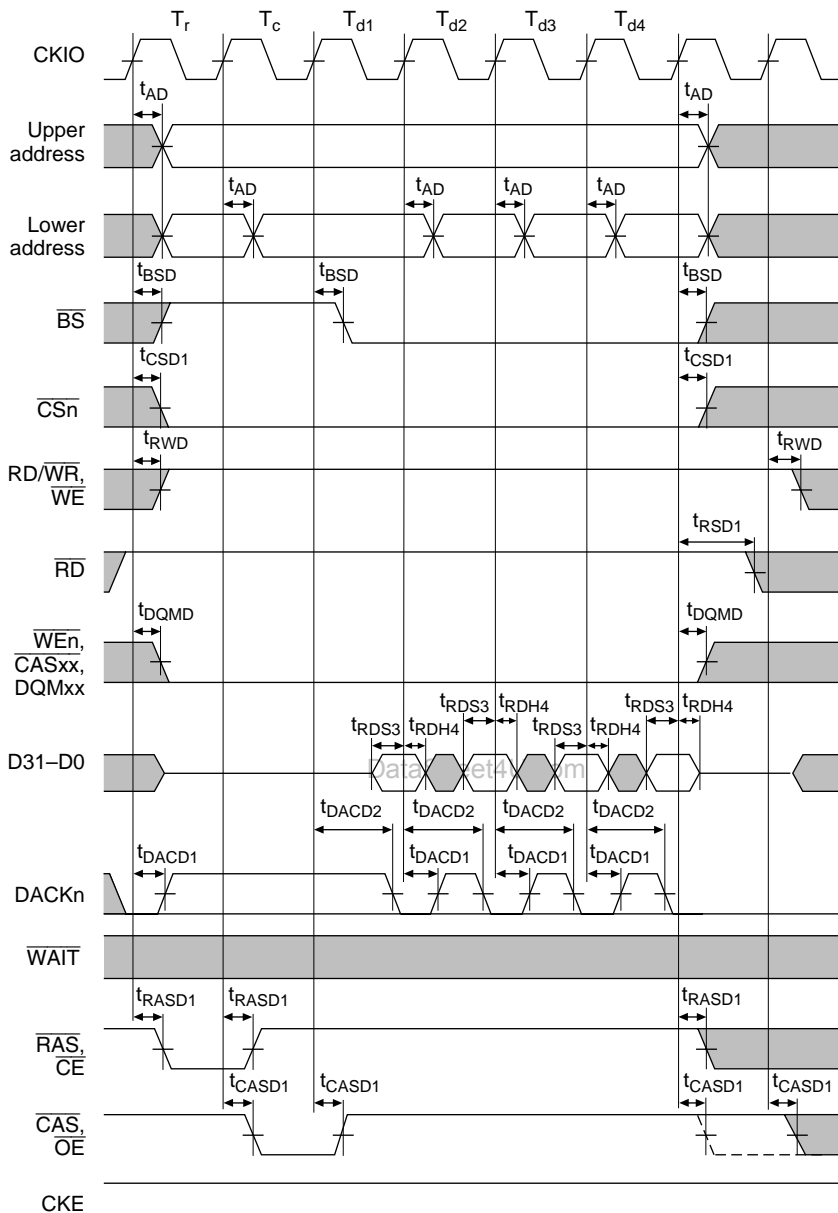

- Notes: 1. The dotted line shows the waveform when synchronous DRAM in another CS space is accessed.
 2. The DACKn waveform shown is for the case where active-high has been specified.

Figure 16.20 Synchronous DRAM Read Bus Cycle
 (RCD = 1 Cycle, CAS Latency = 1 Cycle, Bursts = 4, PLL On)

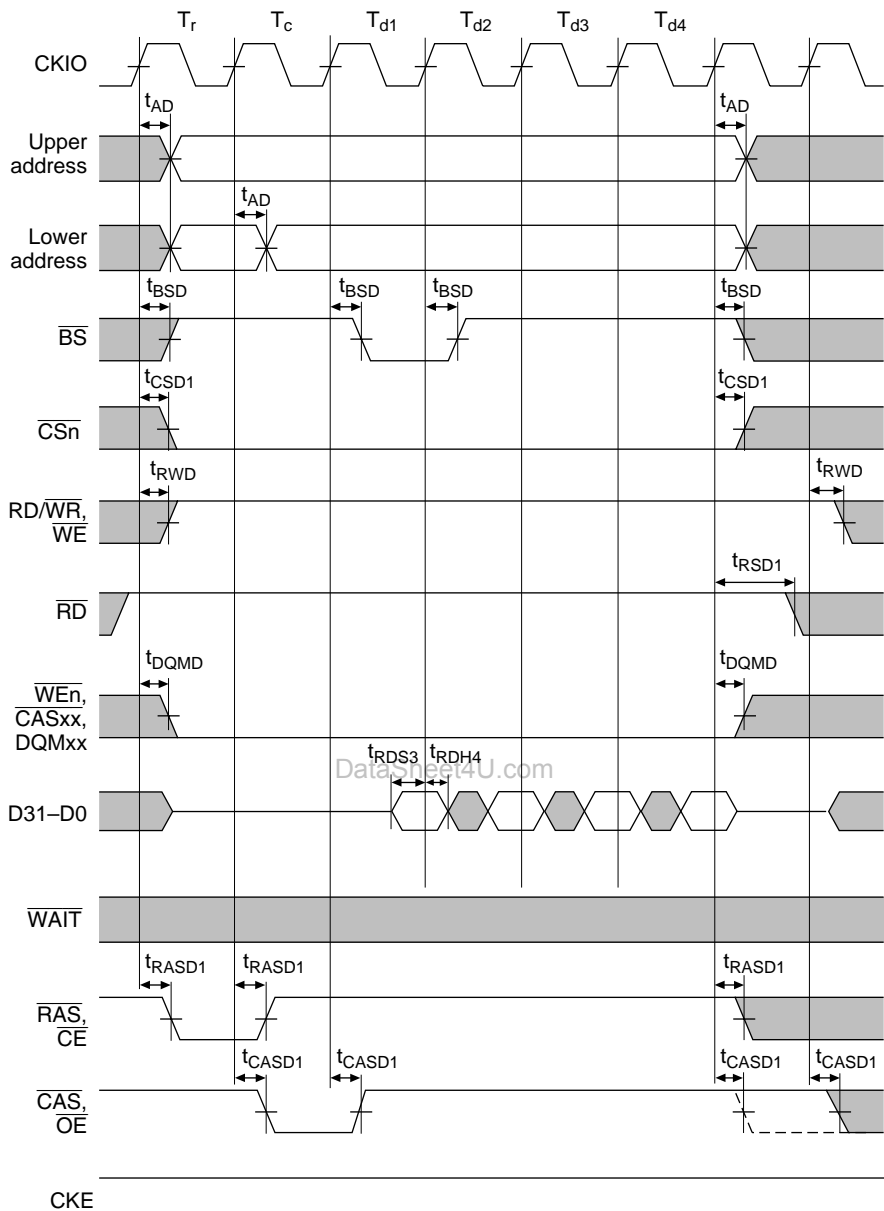

Note: The dotted line shows the waveform when synchronous DRAM in another CS space is accessed.

Figure 16.21 Synchronous DRAM Single Read Bus Cycle
(RCD = 1 Cycle, CAS Latency = 1 Cycle, Bursts = 4, PLL On)

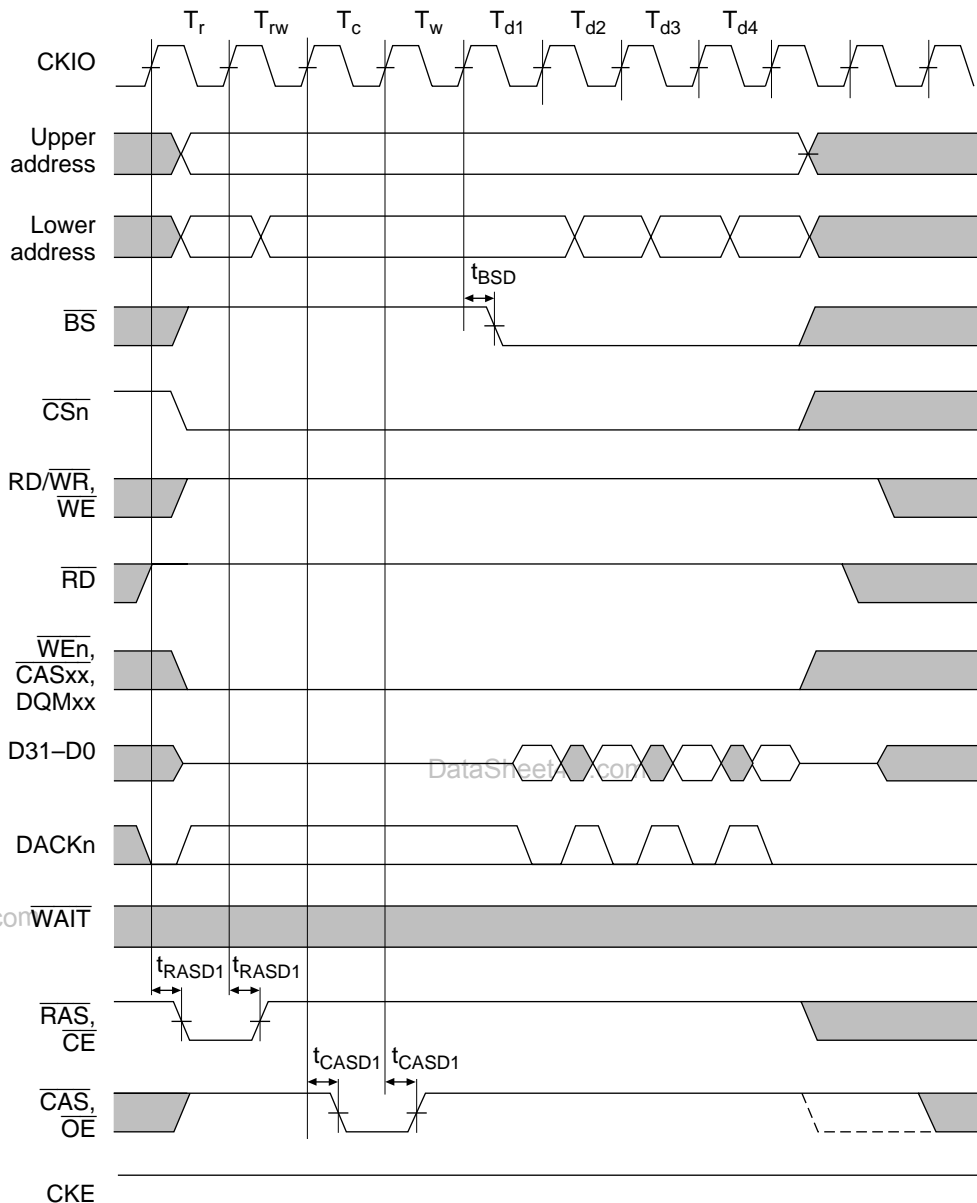

- Notes: 1. The dotted line shows the waveform when synchronous DRAM in another CS space is accessed.
 2. The DACKn waveform shown is for the case where active-high has been specified.

Figure 16.22 Synchronous DRAM Read Bus Cycle
(RCD = 2 Cycles, CAS Latency = 2 Cycles, Bursts = 4)

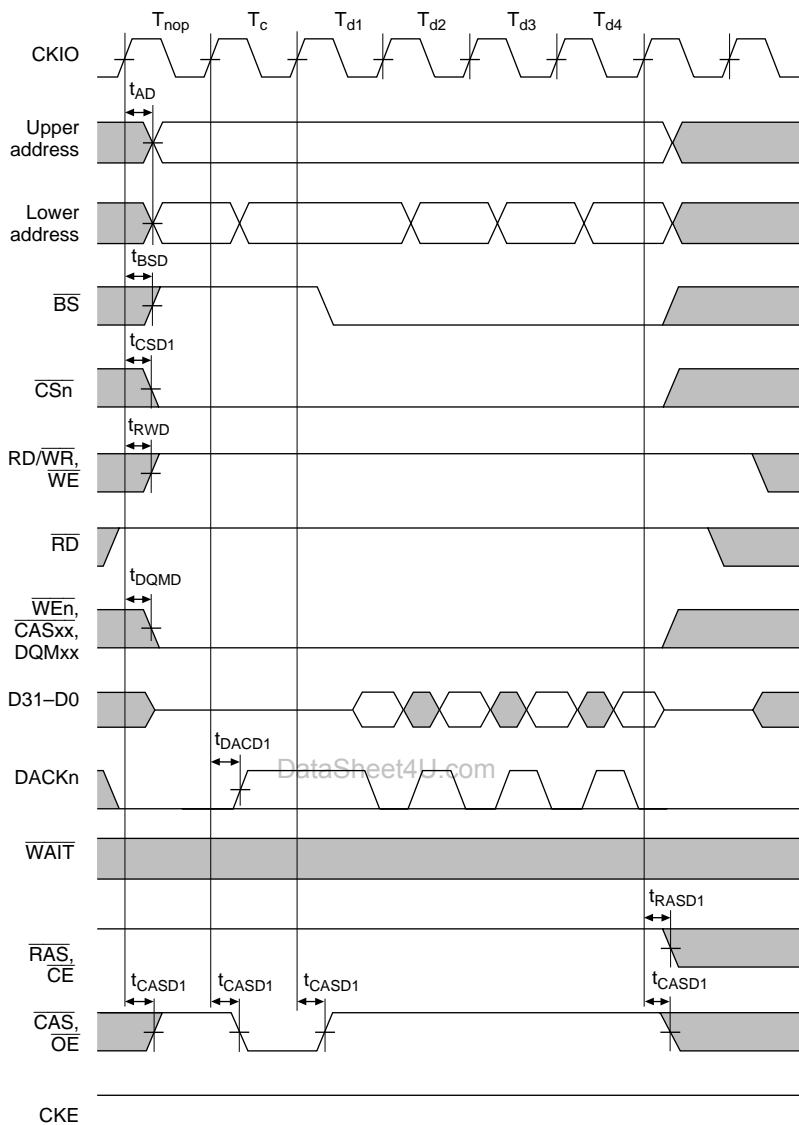

Note: The DACKn waveform shown is for the case where active-high has been specified.

**Figure 16.23 Synchronous DRAM Read Bus Cycle
(Bank Active, Same Row Access, CAS Latency = 1 Cycle)**

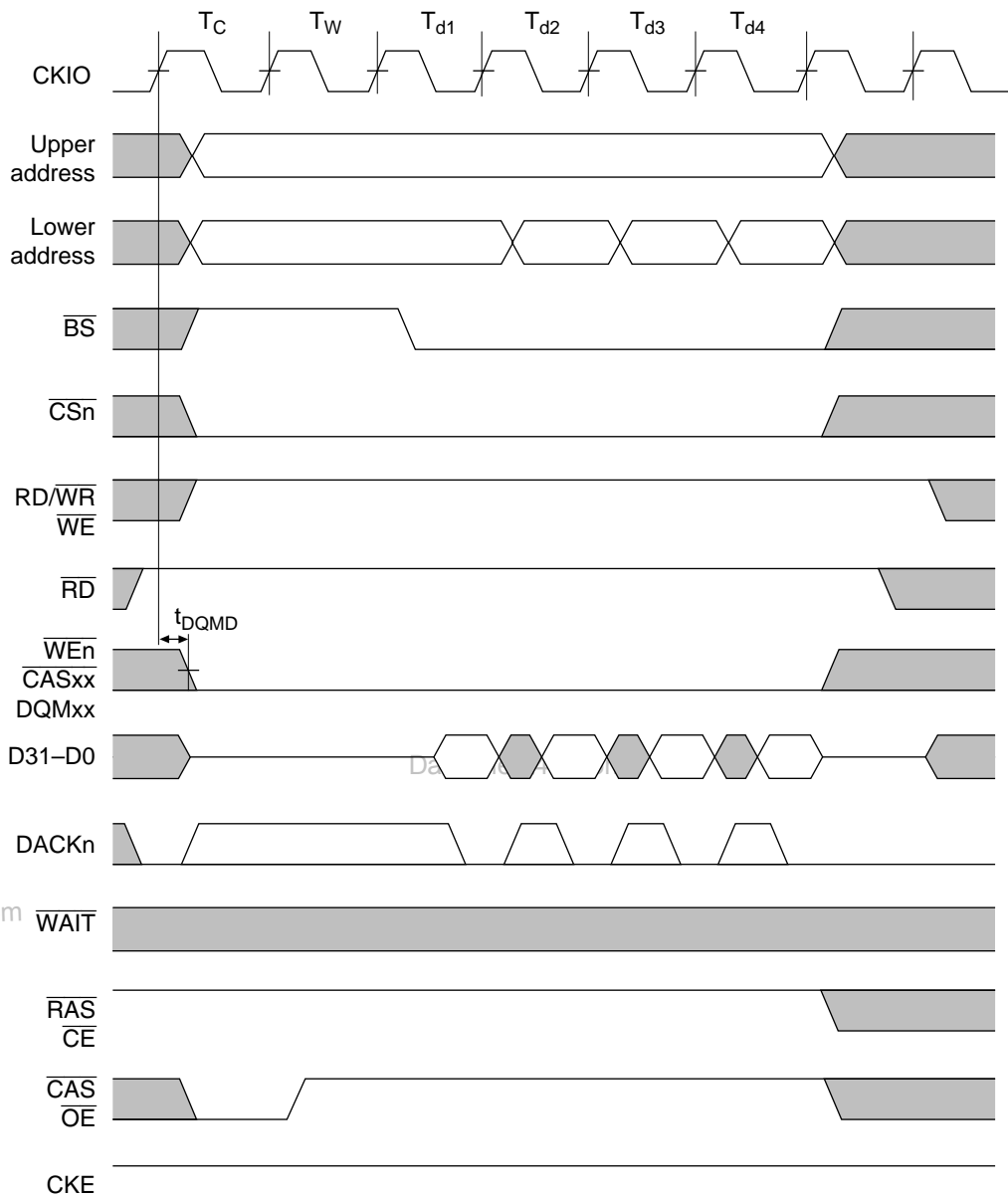

Note: The DACKn waveform shown is for the case where active-high has been specified.

**Figure 16.24 Synchronous DRAM Read Bus Cycle
(Bank Active, Same Row Access, CAS Latency = 2 Cycles)**

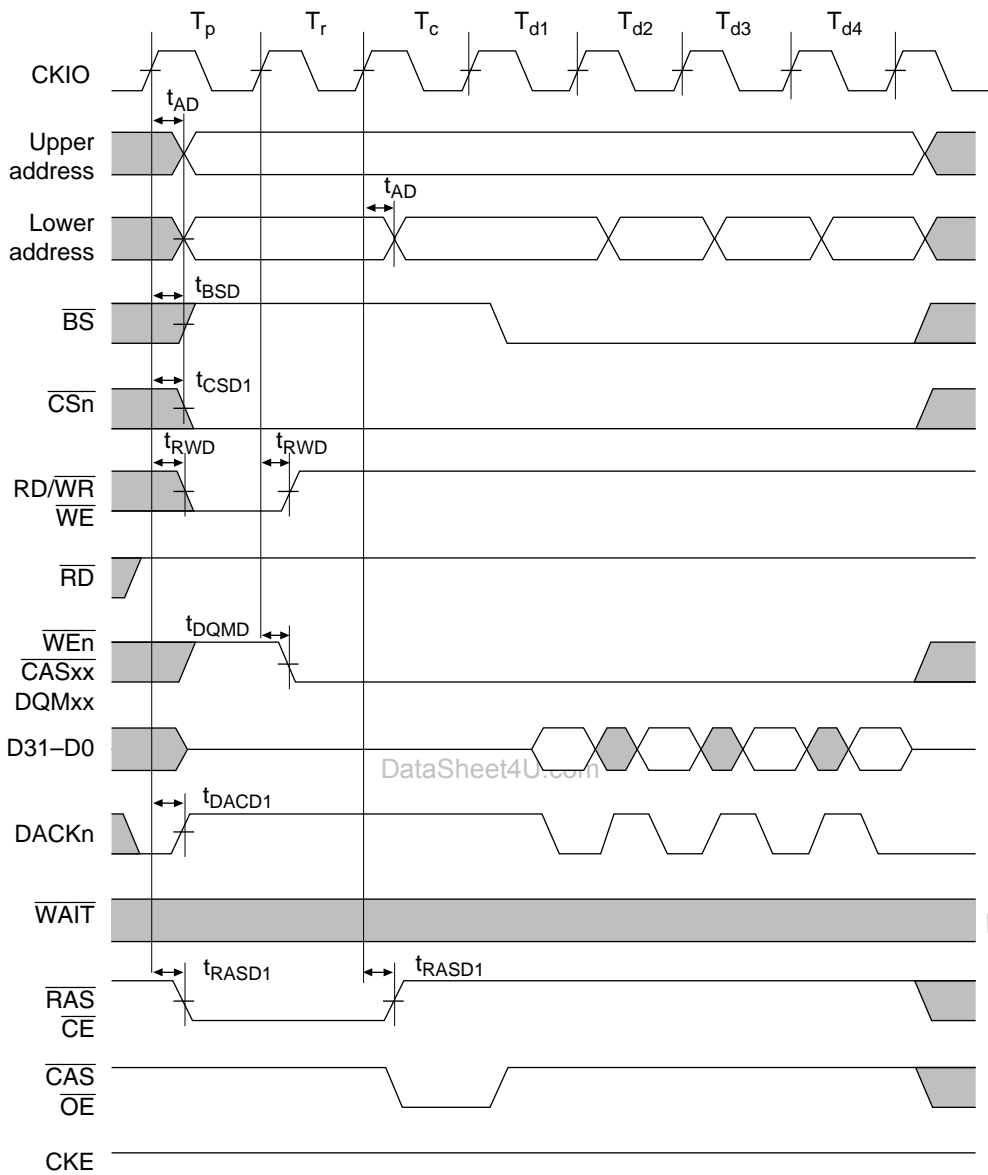

Note: The DACKn waveform shown is for the case where active-high has been specified.

Figure 16.25 Synchronous DRAM Read Bus Cycle (Bank Active, Different Row Access, TRP = 1 Cycle, RCD = 1 Cycle, CAS Latency = 1 Cycle)

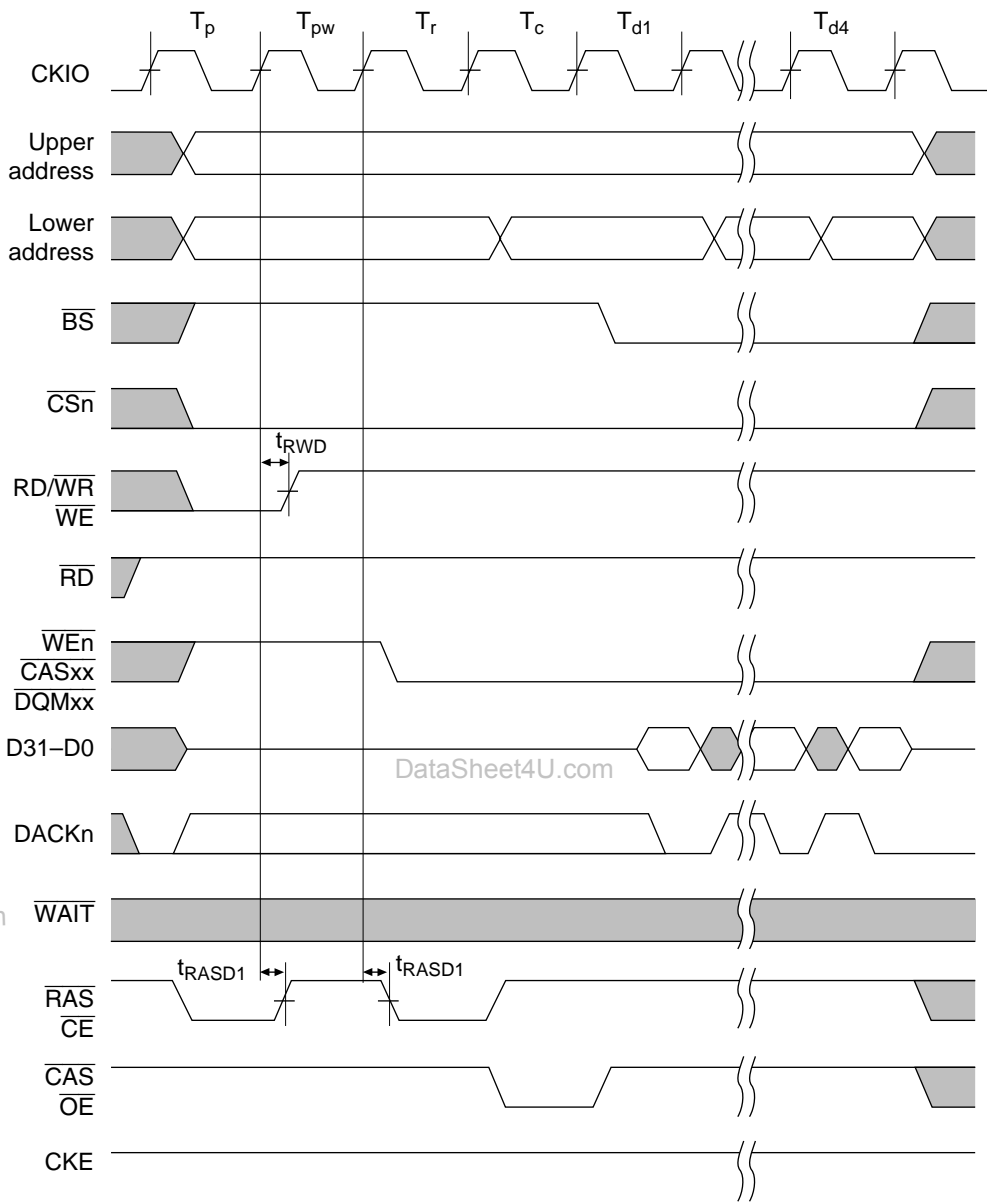

Note: The DACKn waveform shown is for the case where active-high has been specified.

Figure 16.26 Synchronous DRAM Read Bus Cycle (Bank Active, Different Row Access, TRP = 2 Cycles, RCD = 1 Cycle, CAS Latency = 1 Cycle)

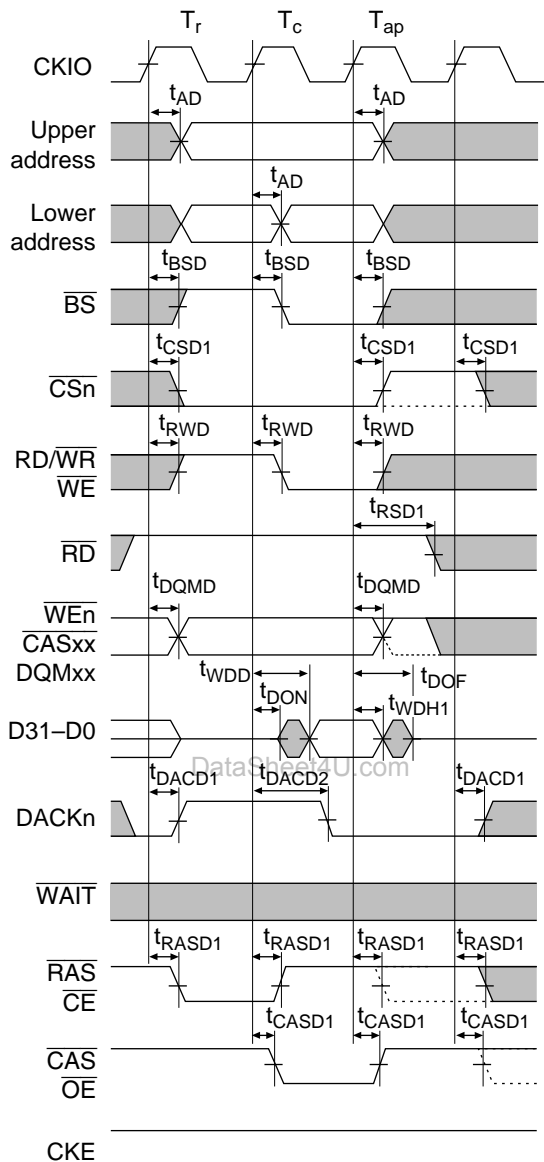

- Notes: 1. Dotted lines show the waveforms when synchronous DRAM in another CS space is accessed.
 2. The DACKn waveform shown is for the case where active-high has been specified.

Figure 16.27 Synchronous DRAM Write Bus Cycle
 (RCD = 1 Cycle, TRWL = 1 Cycle, PLL On)

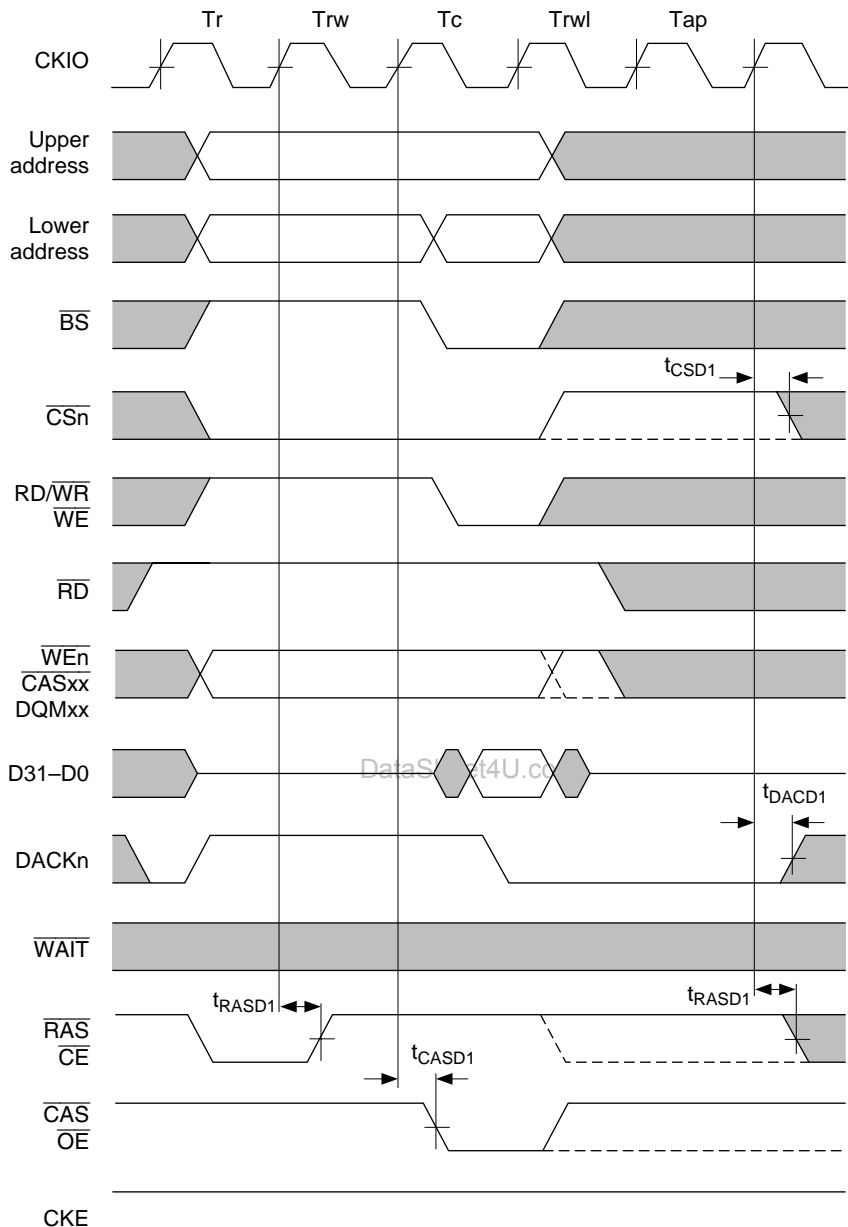

- Notes:
1. Dotted lines show the waveforms when synchronous DRAM in another CS space is accessed.
 2. The DACK_n waveform shown is for the case where active-high has been specified.

Figure 16.28 Synchronous DRAM Write Bus Cycle
(RCD = 2 Cycles, TRWL = 2 Cycles)

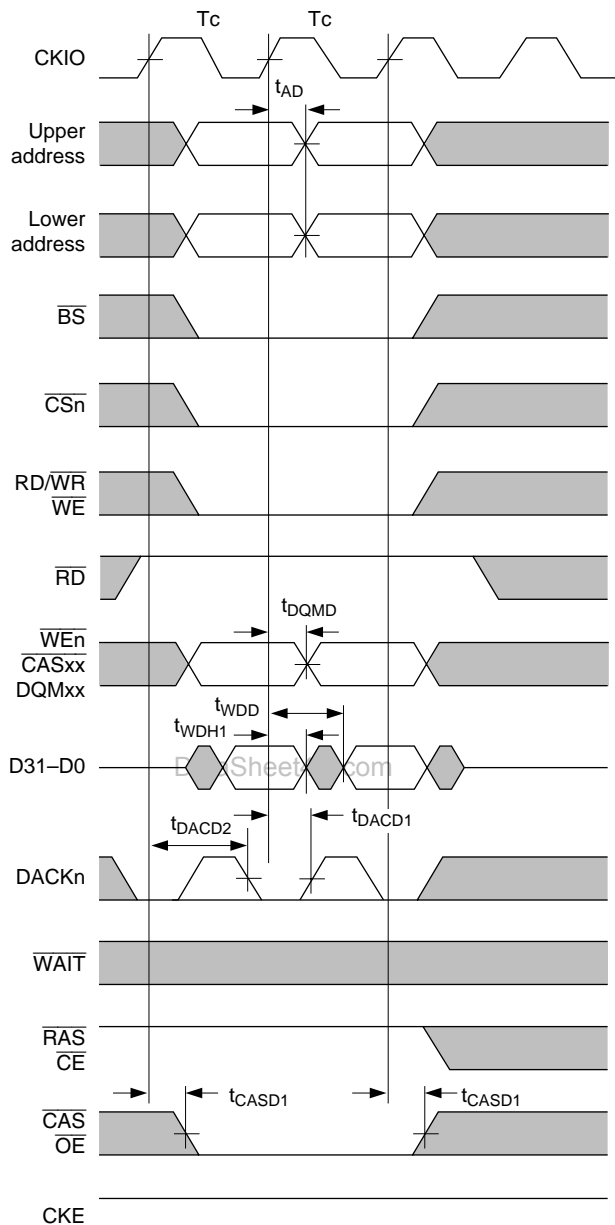

Note: The DACK $_n$ waveform shown is for the case where active-high has been specified.

Figure 16.30 Synchronous DRAM Consecutive Write Cycles (Bank Active, Same Row Access)

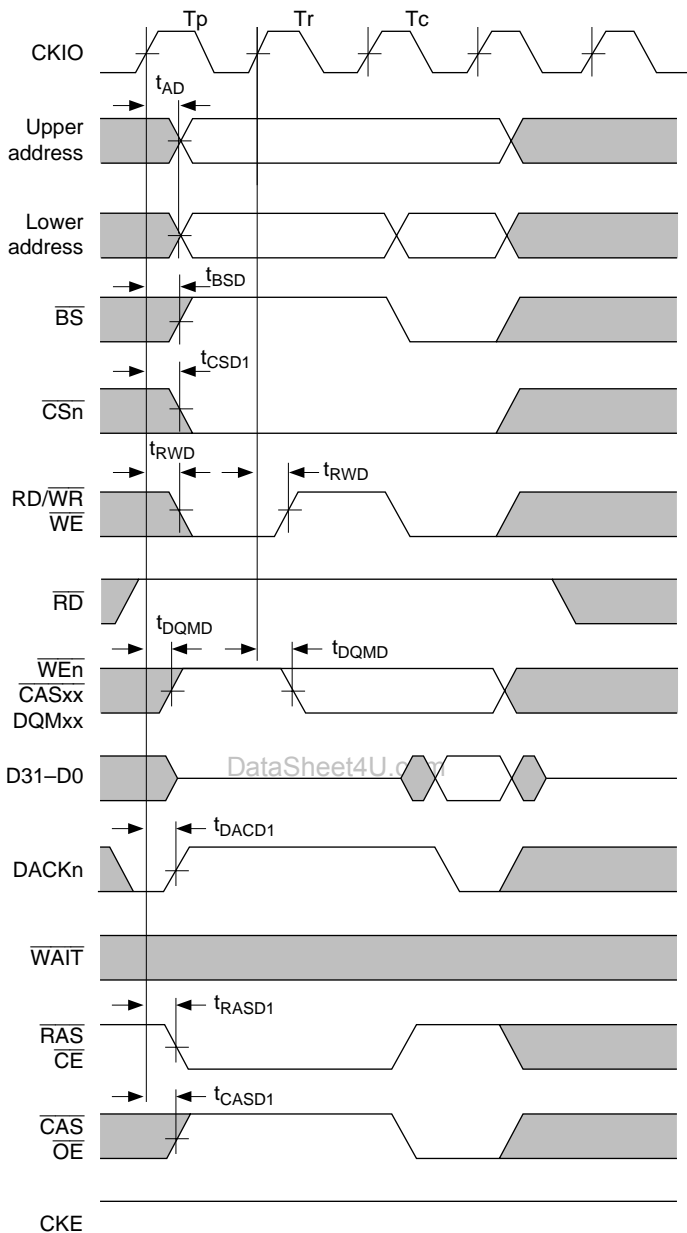

Note: The DACKn waveform shown is for the case where active-high has been specified.

**Figure 16.31 Synchronous DRAM Write Bus Cycle
(Bank Active, Different Row Access, TRP = 1 Cycle, RCD = 1 Cycle)**

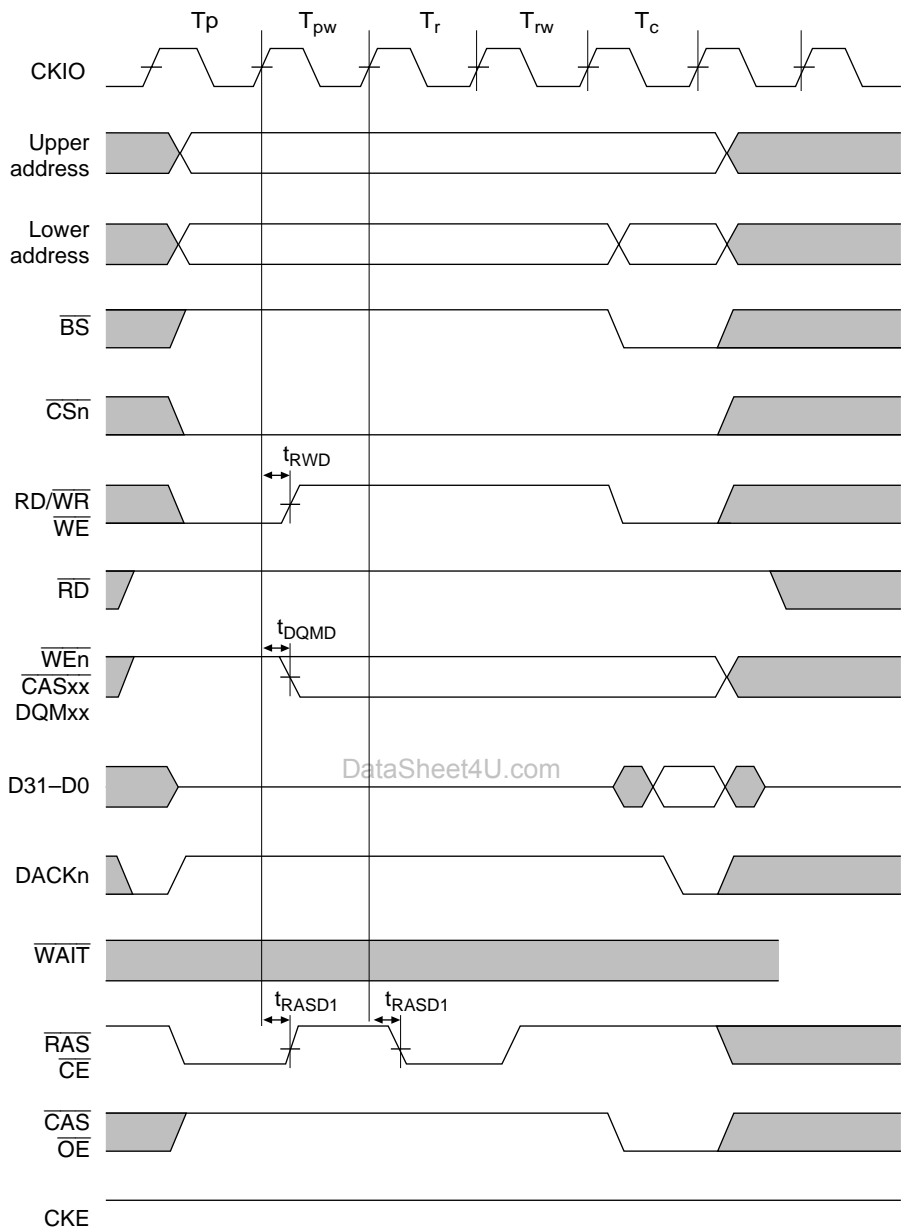

Note: The DACKn waveform shown is for the case where active-high has been specified.

Figure 16.32 Synchronous DRAM Write Bus Cycle
(Bank Active, Different Row Access, TRP = 2 Cycles, RCD = 2 Cycles)

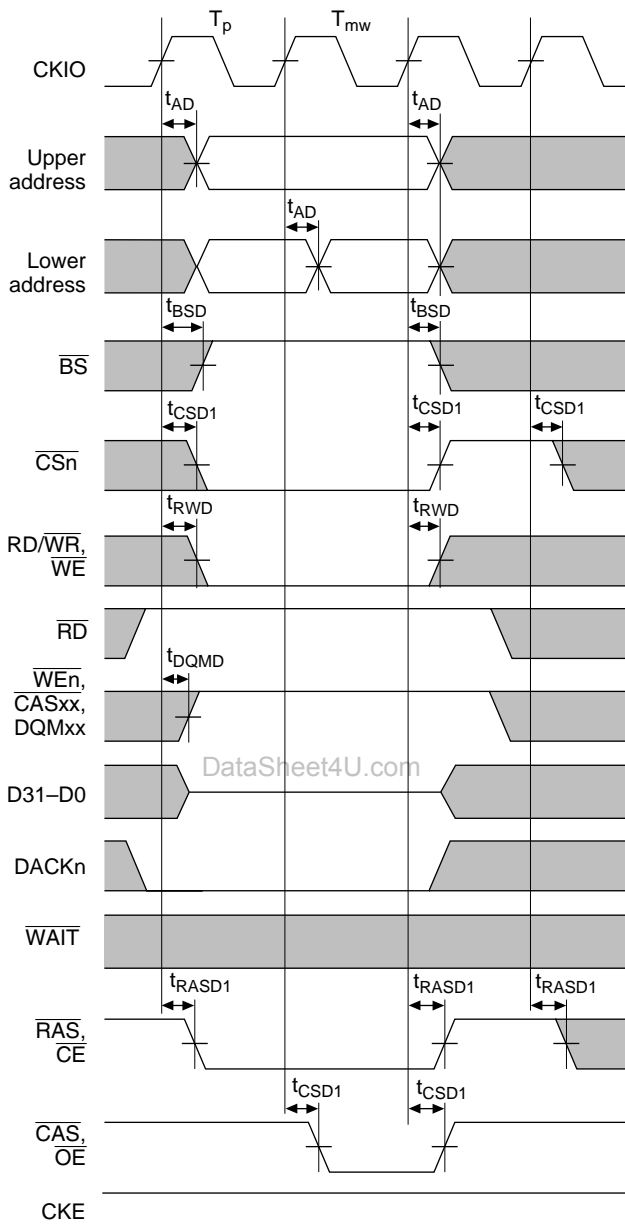

Figure 16.33 Synchronous DRAM Mode Register Write Cycle (TRP = 1 Cycle)

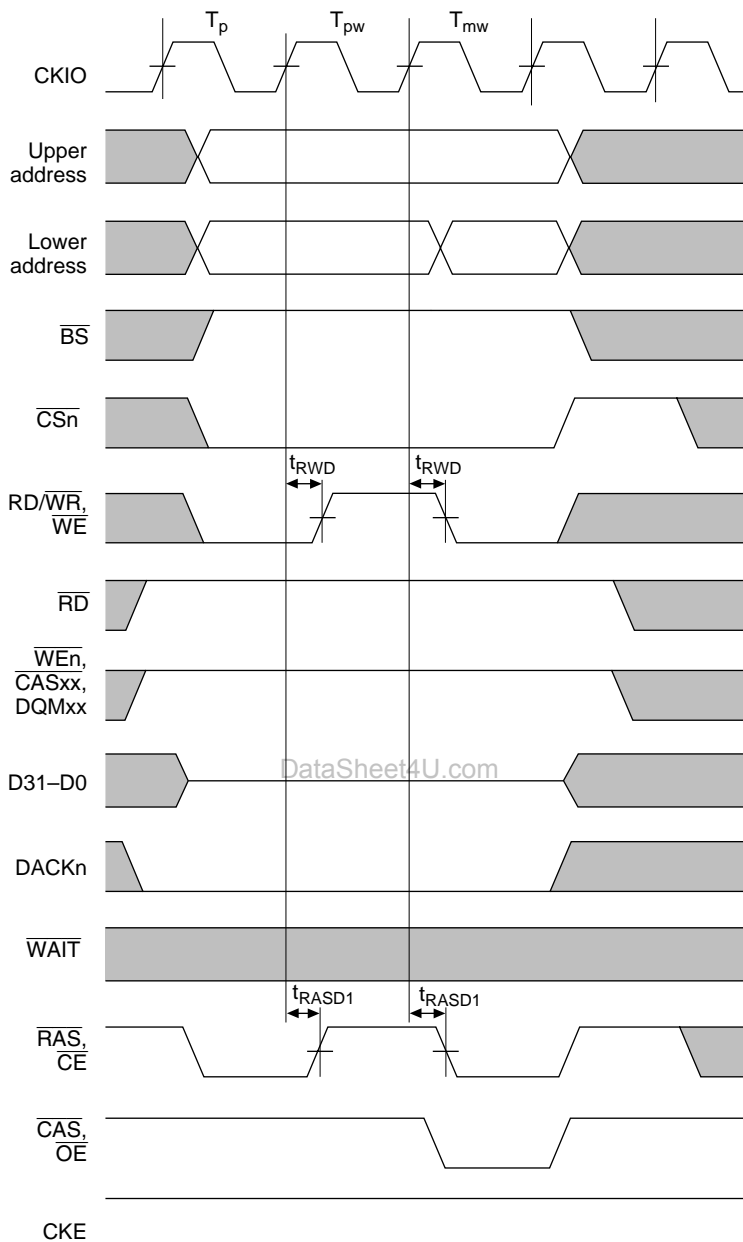
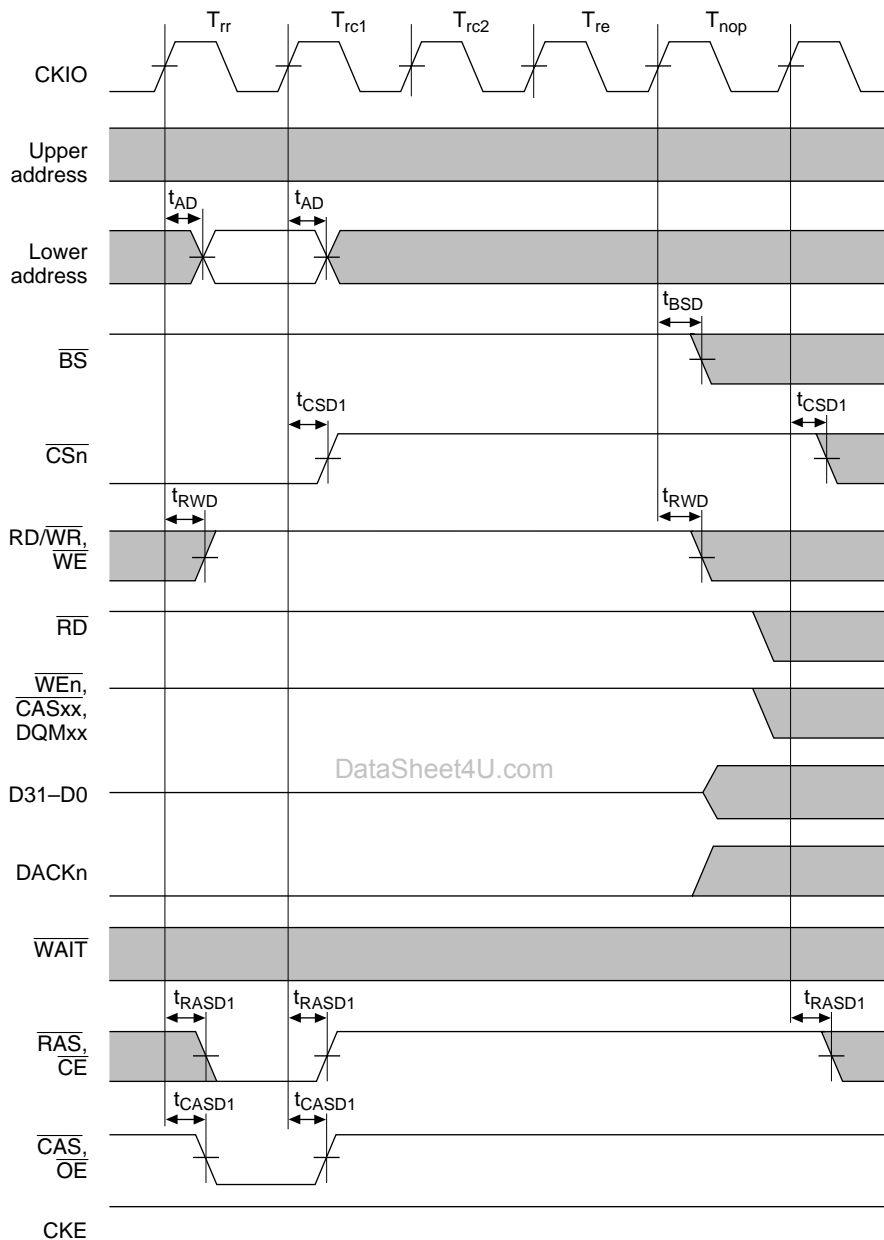

Figure 16.34 Synchronous DRAM Mode Register Write Cycle (TRP = 2 Cycles)



Note: A precharge cycle always precedes the auto-refresh cycle by the number of cycles specified by TRP.

Figure 16.35 Synchronous DRAM Auto-Refresh Cycle ($TRAS = 2$ Cycles)

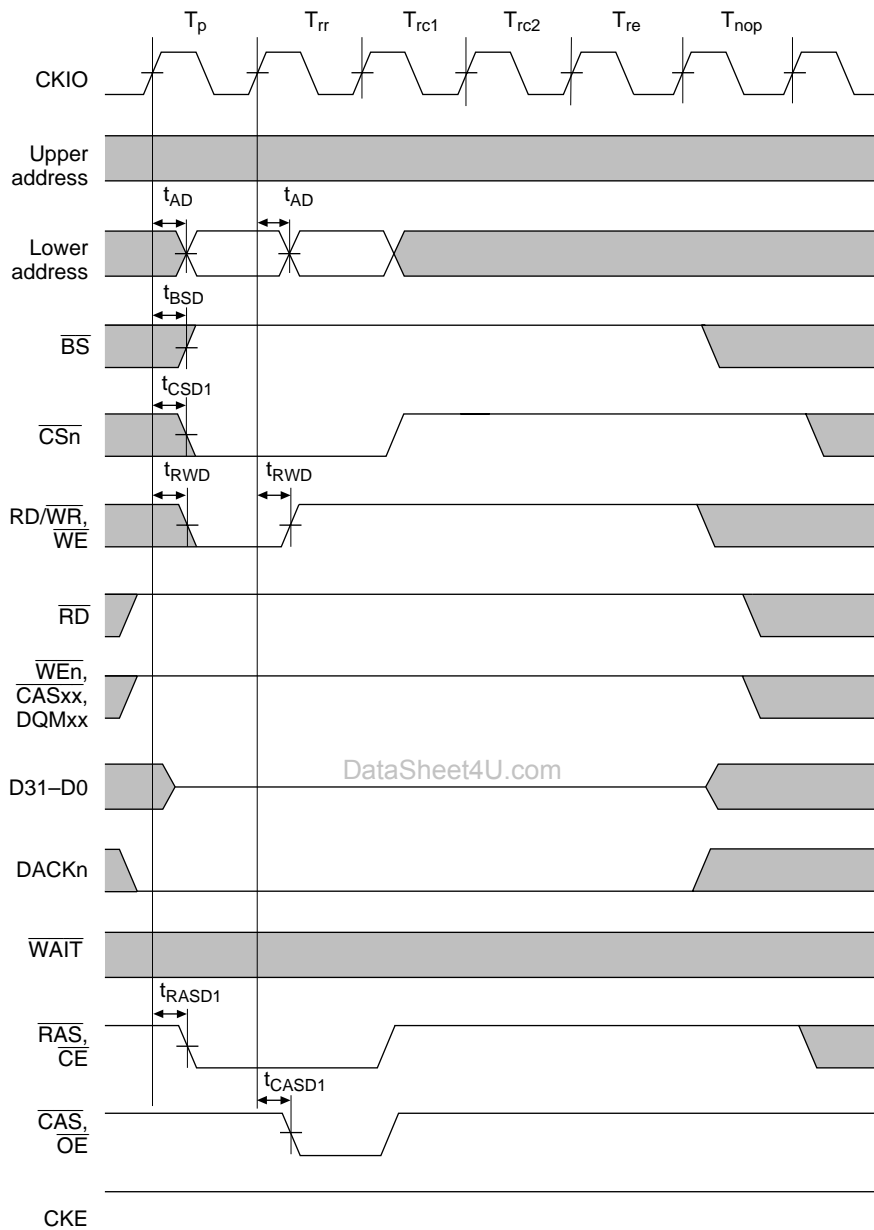
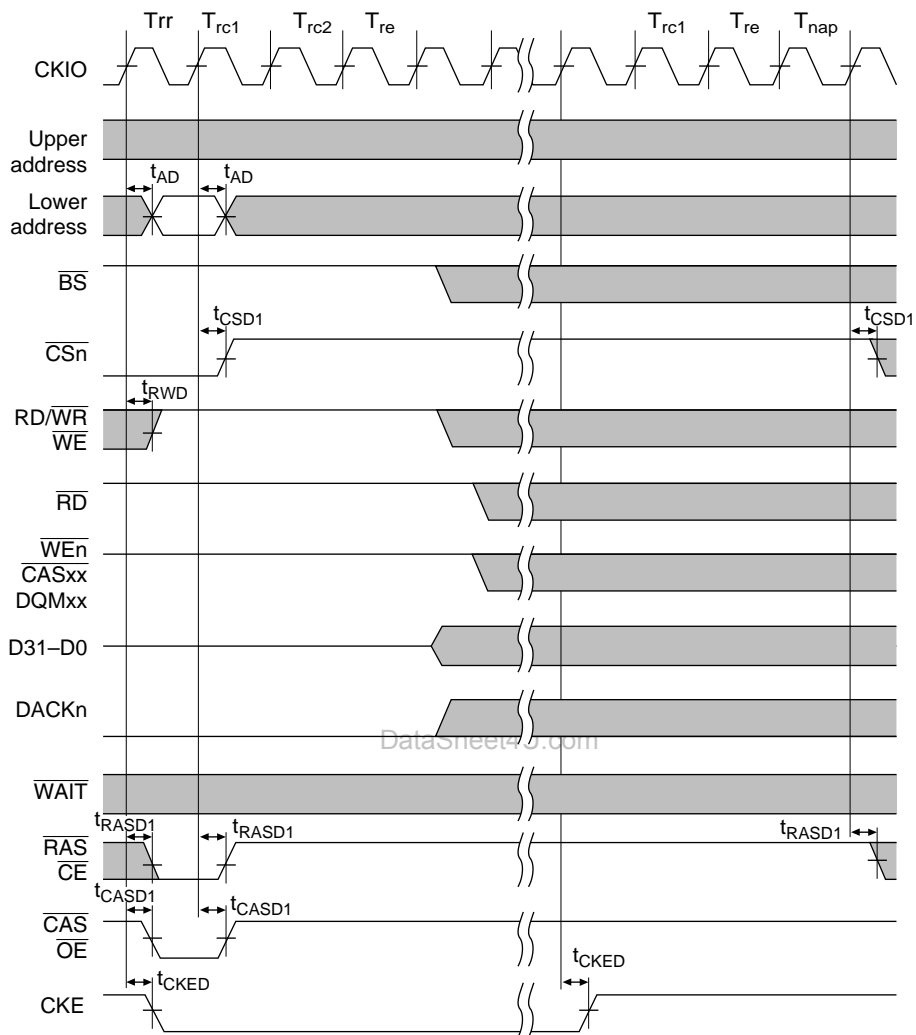
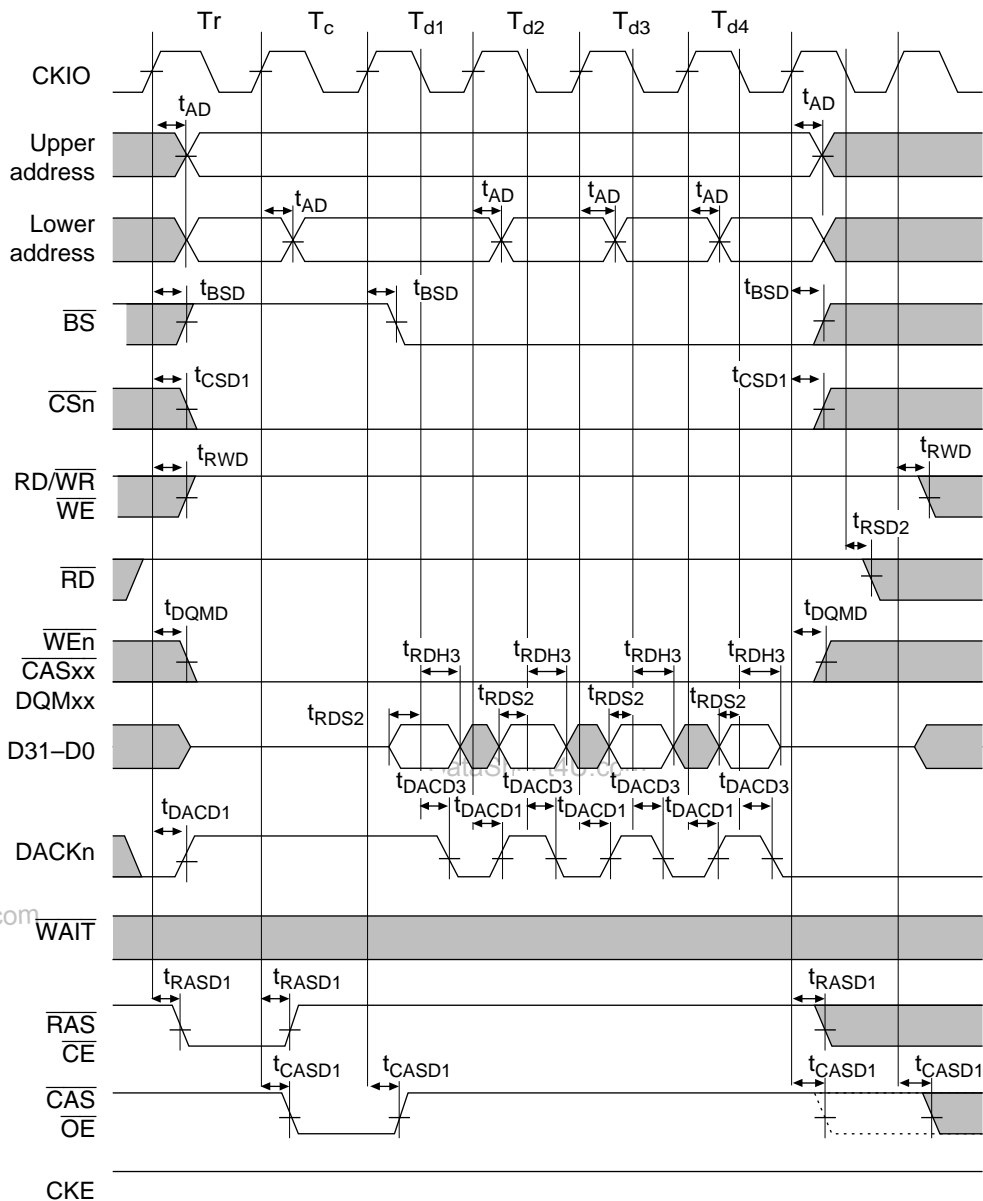

Figure 16.36 Synchronous DRAM Auto-Refresh Cycle
 (Shown From Precharge Cycle, TRP = 1 Cycle, TRAS = 2 Cycles)



Note: A precharge cycle always precedes the self-refresh cycle by the number of cycles specified by TRP.

Figure 16.37 Synchronous DRAM Self-Refresh Cycle ($TRAS = 2$)



- Notes: 1. The dotted line shows the waveform when synchronous DRAM in another CS space is accessed.
 2. The DACKn waveform shown is for the case where active-high has been specified.

Figure 16.38 Synchronous DRAM Read Bus Cycle

(RCD = 1 Cycle, CAS Latency = 1 Cycle, TRP = 1 Cycle, Bursts = 4, PLL Off)

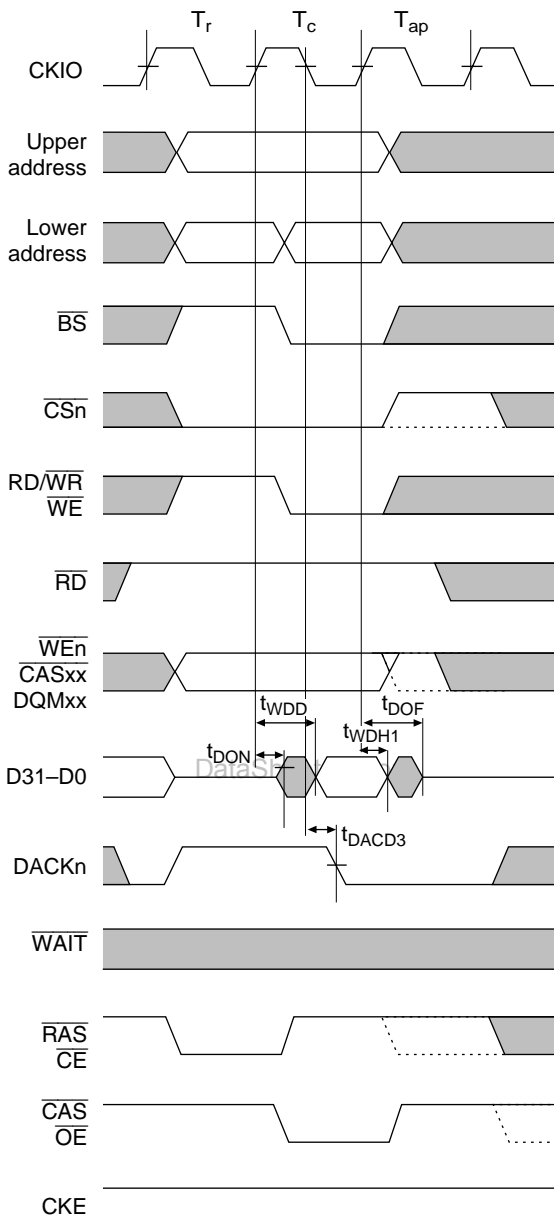

- Notes:
1. Dotted lines show the waveforms when synchronous DRAM in another CS space is accessed.
 2. The DACKn waveform shown is for the case where active-high has been specified.

Figure 16.39 Synchronous DRAM Write Bus Cycle
(RCD = 1 Cycle, TRWL = 1 Cycle, PLL Off)

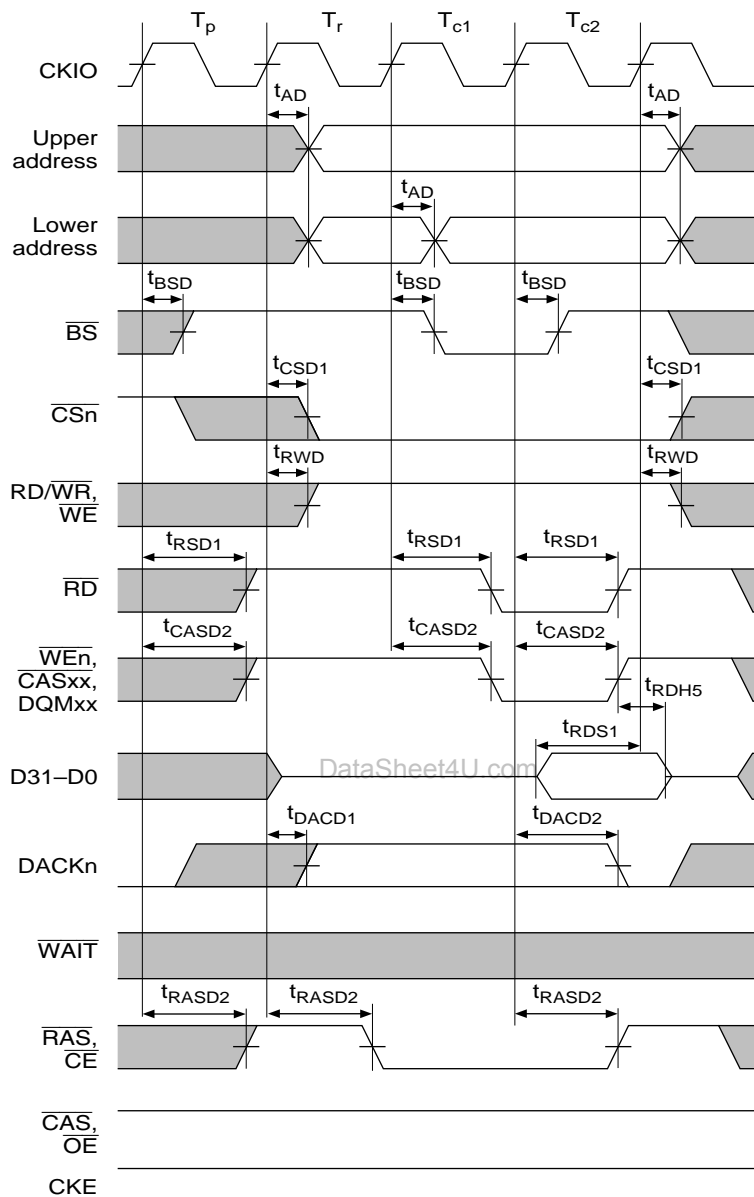

- Notes: 1. t_{RDH5} is specified from the rise of \overline{RD} or \overline{CASxx} , whichever is first.
 2. The $DACKn$ waveform shown is for the case where active-high has been specified.

Figure 16.40 DRAM Read Cycle (TRP = 1 Cycle, RCD = 1 Cycle, No Waits, PLL On)

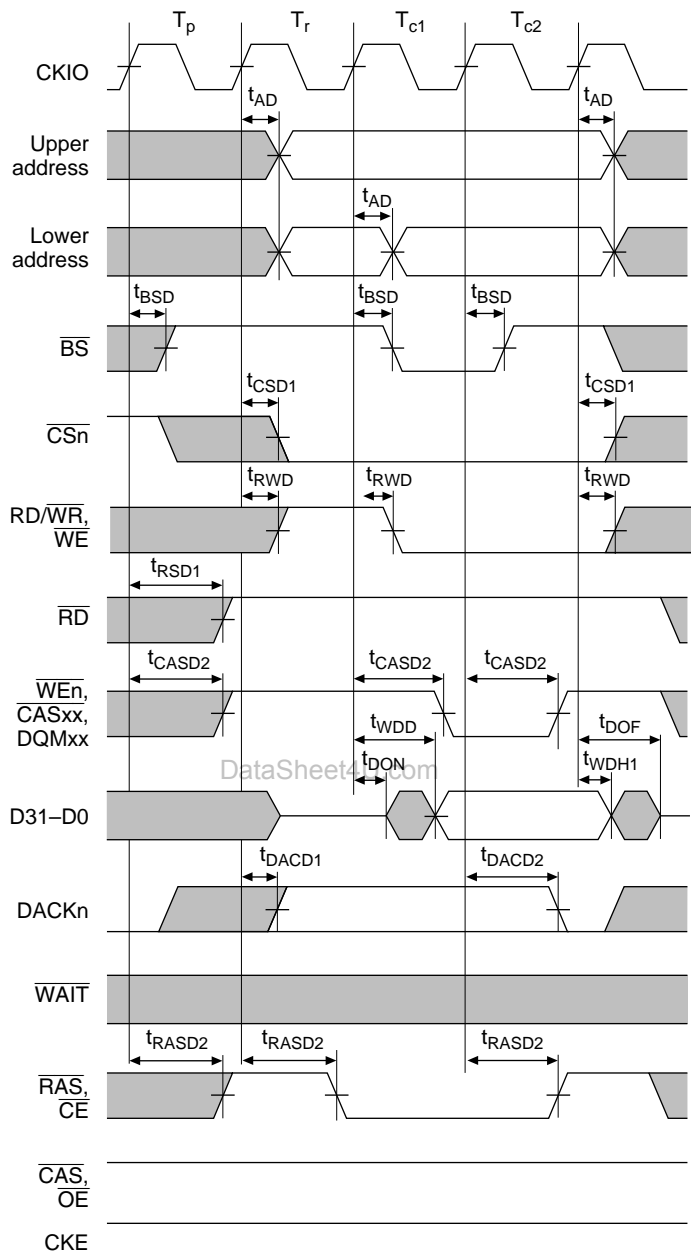

Note: The \overline{DACKn} waveform shown is for the case where active-high has been specified.

Figure 16.41 DRAM Write Cycle
(TRP = 1 Cycle, RCD = 1 Cycle, No Waits, PLL On)

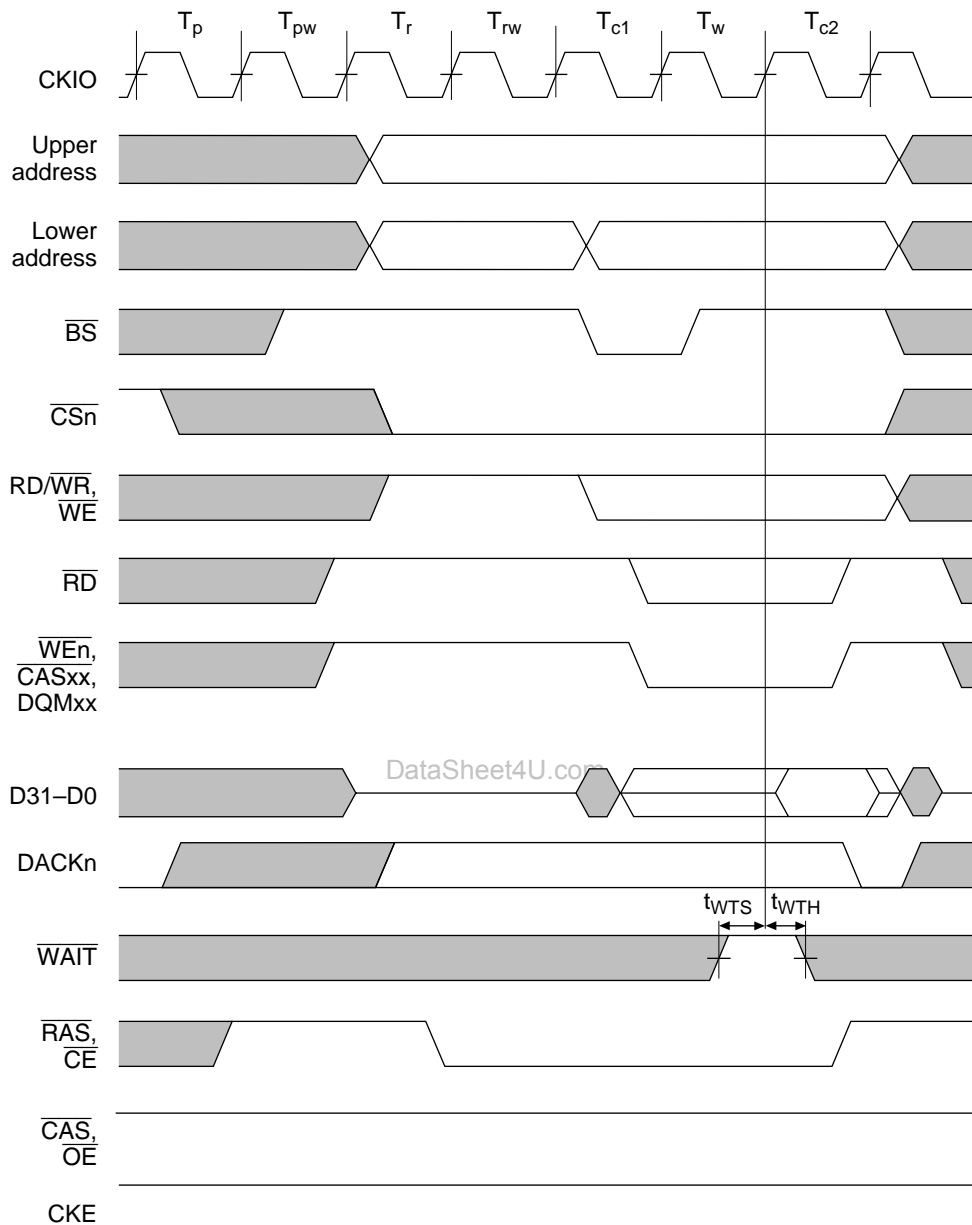

Note: The DACKn waveform shown is for the case where active-high has been specified.

Figure 16.42 DRAM Bus Cycle (TRP = 2 Cycles, RCD = 2 Cycles, 1 Wait)

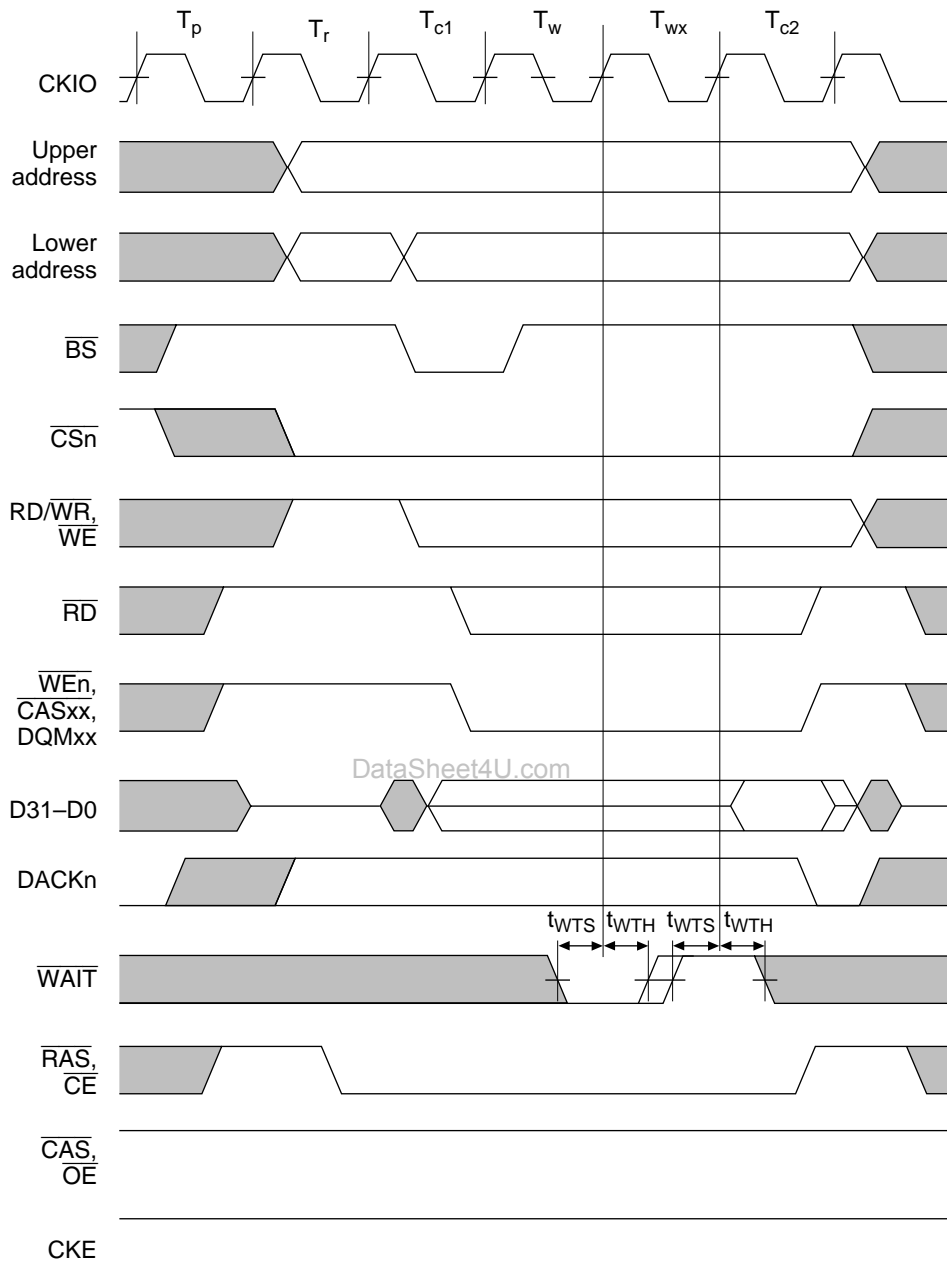

Note: The DACKn waveform shown is for the case where active-high has been specified.

Figure 16.43 DRAM Bus Cycle (TRP = 1 Cycle, RCD = 1 Cycle, External Wait Input)

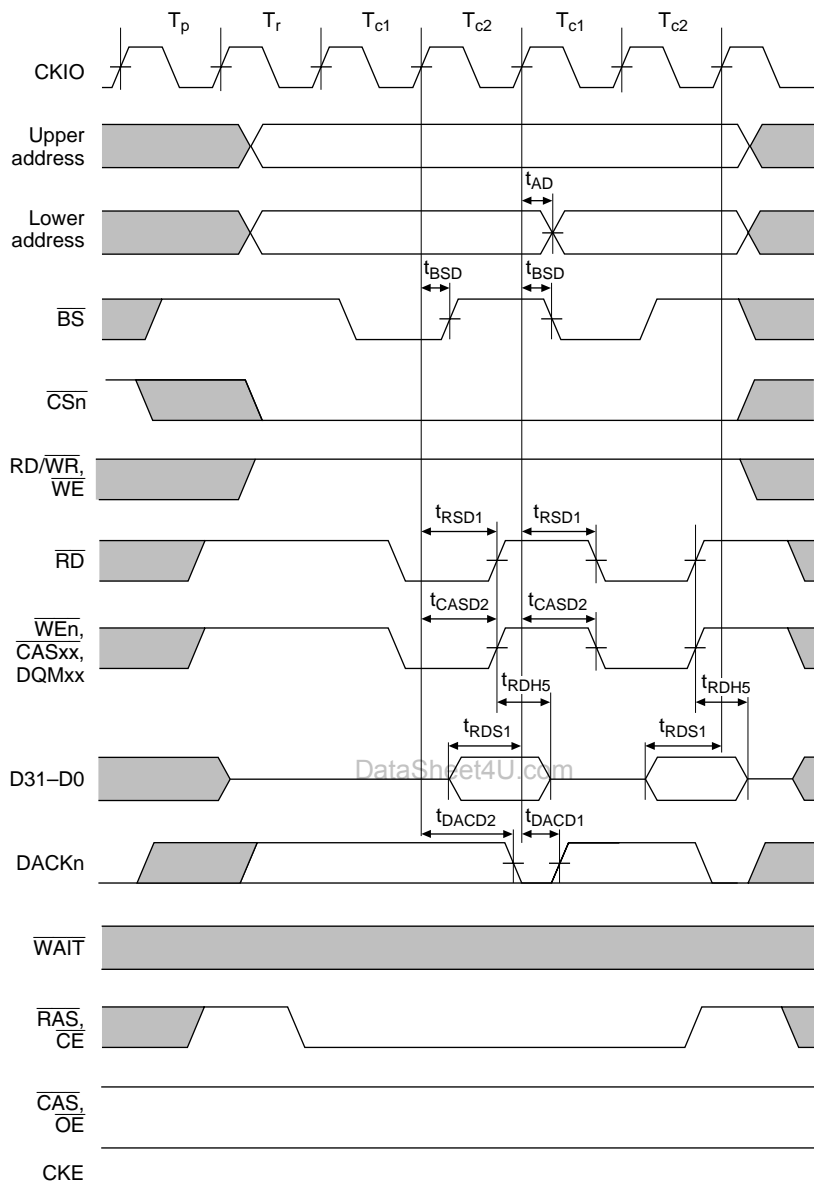

- Notes: 1. t_{RDH5} is specified from the rise of \overline{RD} or \overline{CAS}_{xx} , whichever is first.
 2. The \overline{DACK}_n waveform shown is for the case where active-high has been specified.

Figure 16.44 DRAM Burst Read Cycle
 (TRP = 1 Cycle, RCD = 1 Cycle, No Waits, PLL On)

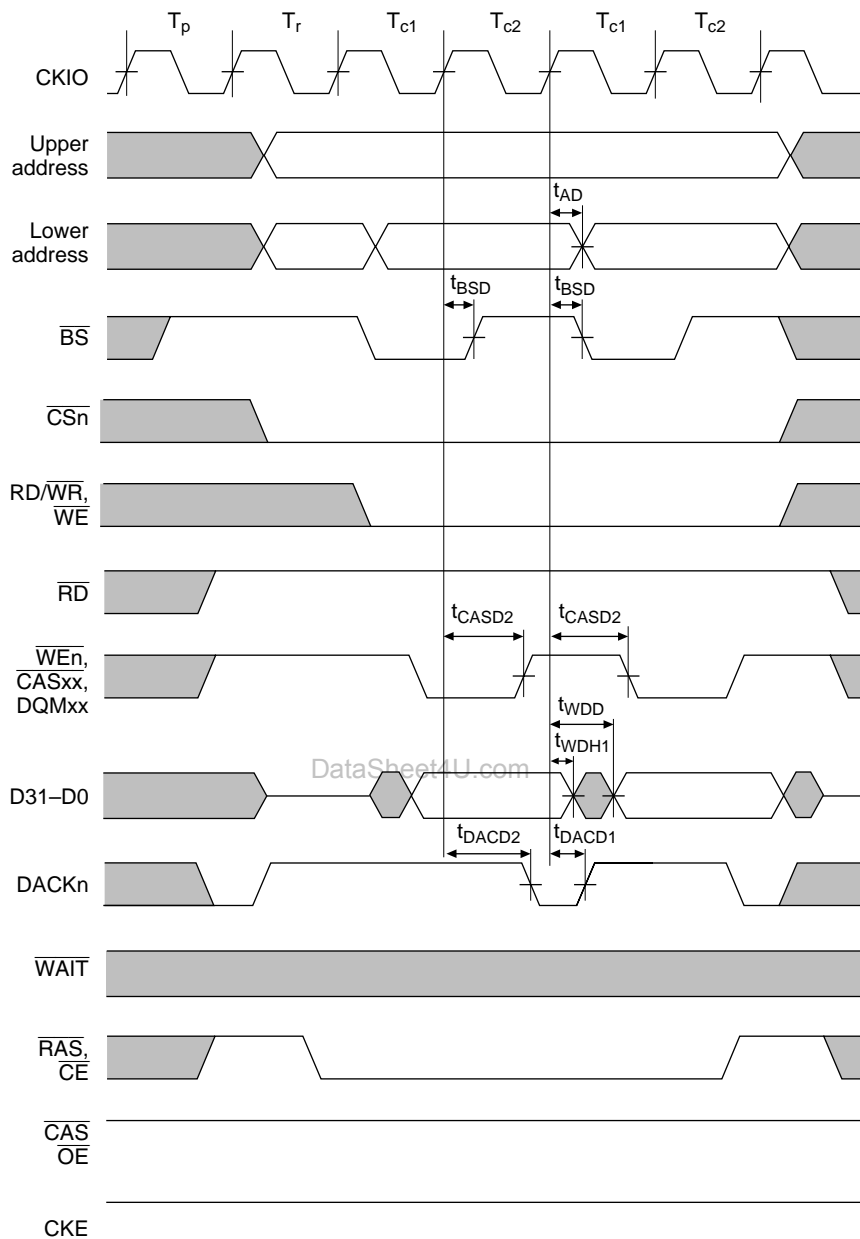

Note: The DACKn waveform shown is for the case where active-high has been specified.

Figure 16.45 DRAM Burst Write Cycle
(TRP = 1 Cycle, RCD = 1 Cycle, No Waits, PLL On)

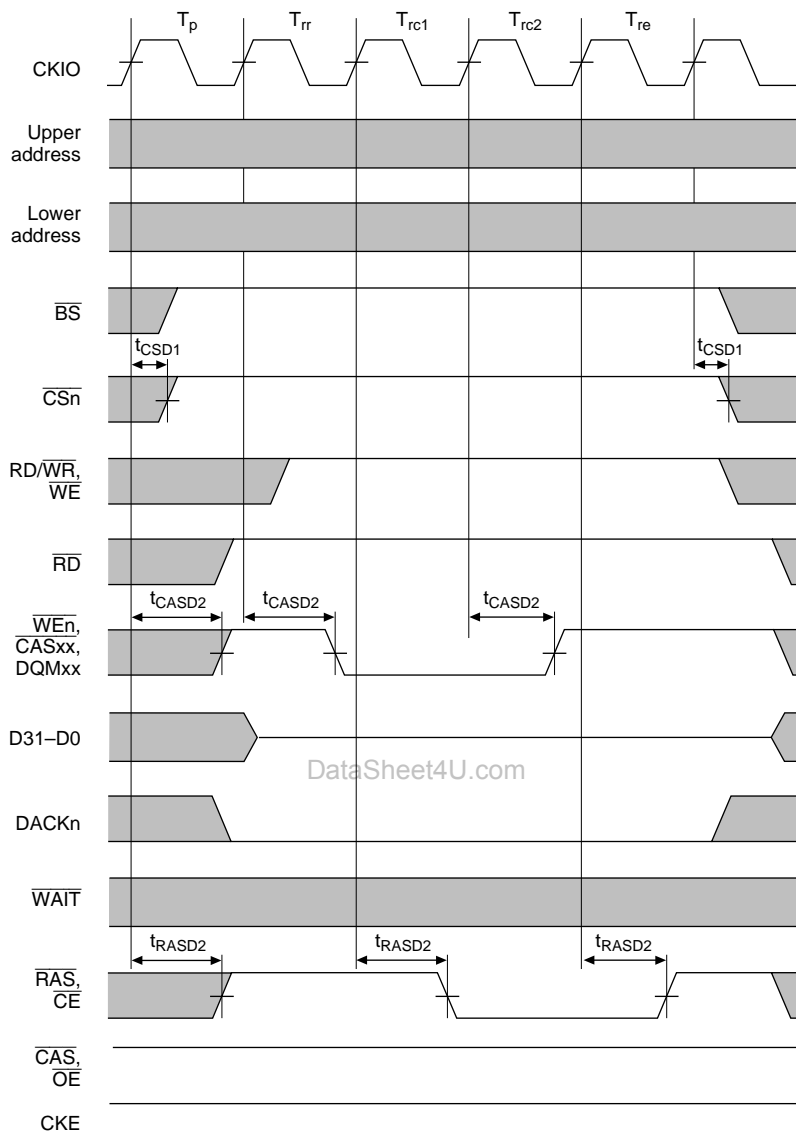
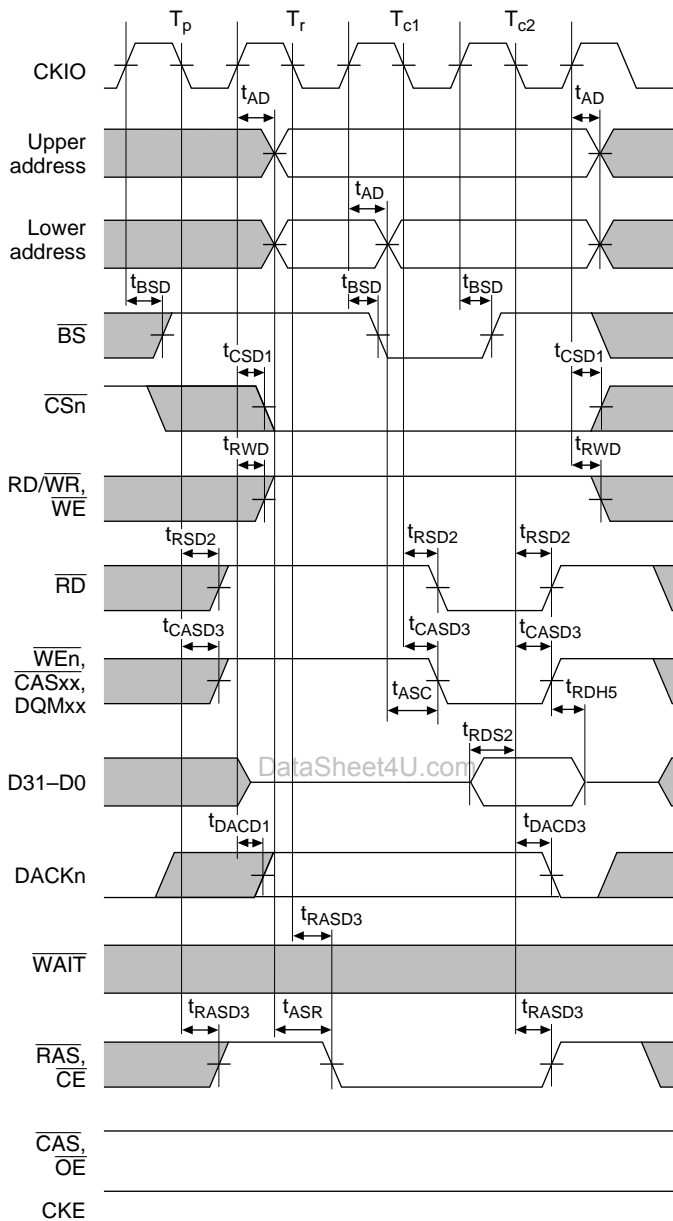
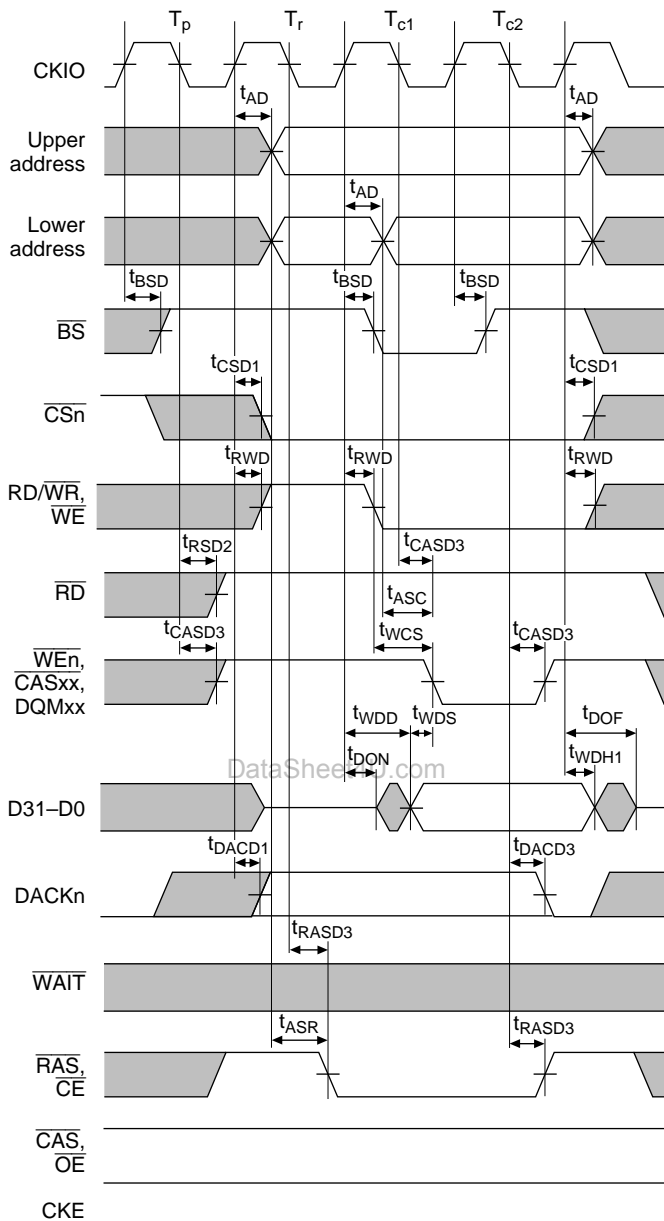

Figure 16.46 DRAM CAS-Before-RAS Refresh Cycle
 (TRP = 1 Cycle, TRAS = 2 Cycles, PLL On)



- Notes: 1. t_{RDH5} is specified from the rise of \overline{RD} or \overline{CASxx} , whichever is first.
 2. The $DACKn$ waveform shown is for the case where active-high has been specified.

Figure 16.47 DRAM Read Cycle (TRP = 1 Cycle, RCD = 1 Cycle, No Waits, PLL Off)



Note: The DACKn waveform shown is for the case where active-high has been specified.

Figure 16.48 DRAM Write Cycle (TRP = 1 Cycle, RCD = 1 Cycle, No Waits, PLL Off)

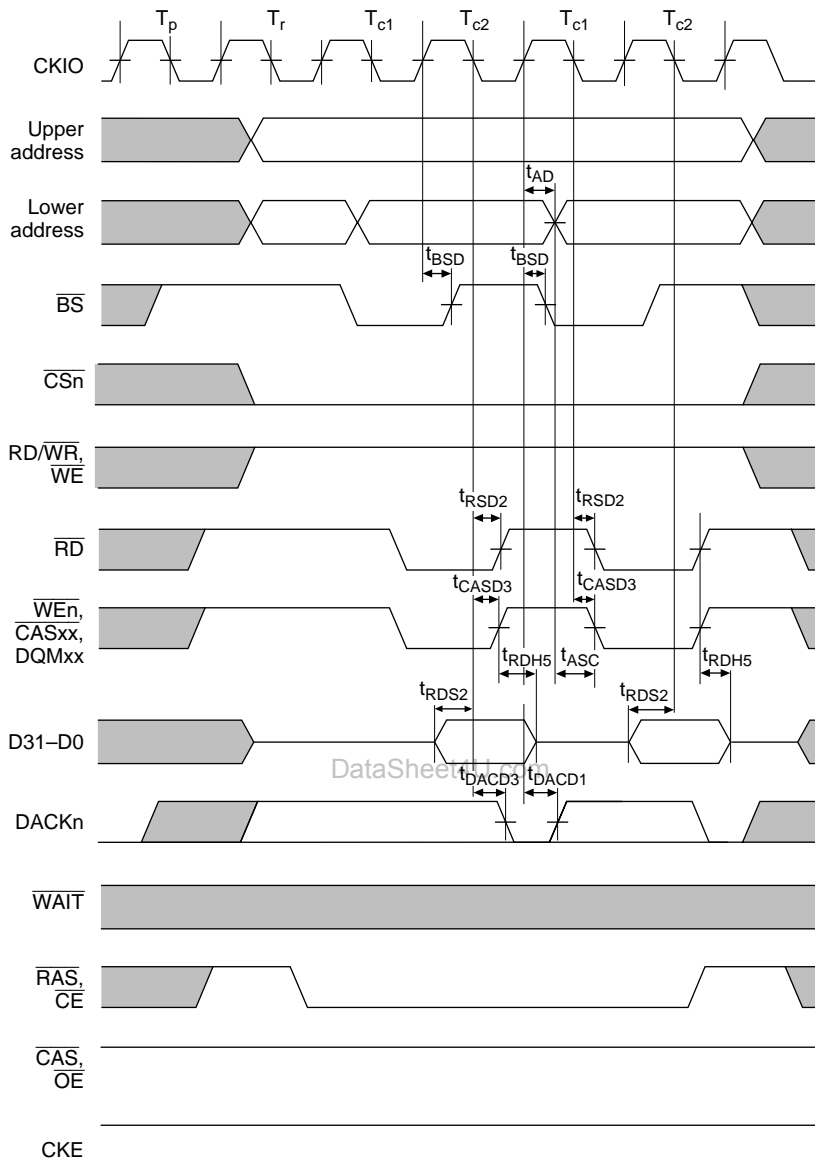

- Notes:
1. t_{RDH5} is specified from the rise of \overline{RD} or \overline{CASxx} , whichever is first.
 2. The $DACKn$ waveform shown is for the case where active-high has been specified.

Figure 16.49 DRAM Burst Read Cycle
(TRP = 1 Cycle, RCD = 1 Cycle, No Waits, PLL Off)

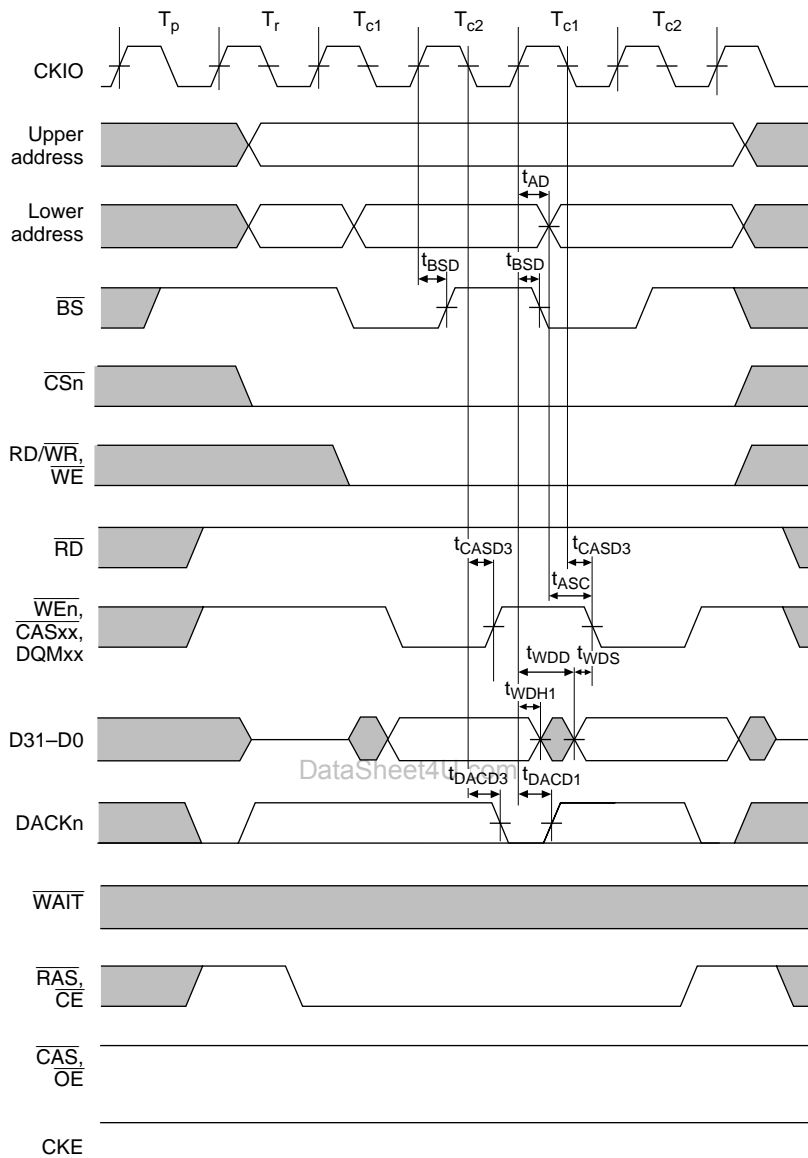

Note: The DACKn waveform shown is for the case where active-high has been specified.

Figure 16.50 DRAM Burst Write Cycle
(TRP = 1 Cycle, RCD = 1 Cycle, No Waits, PLL Off)

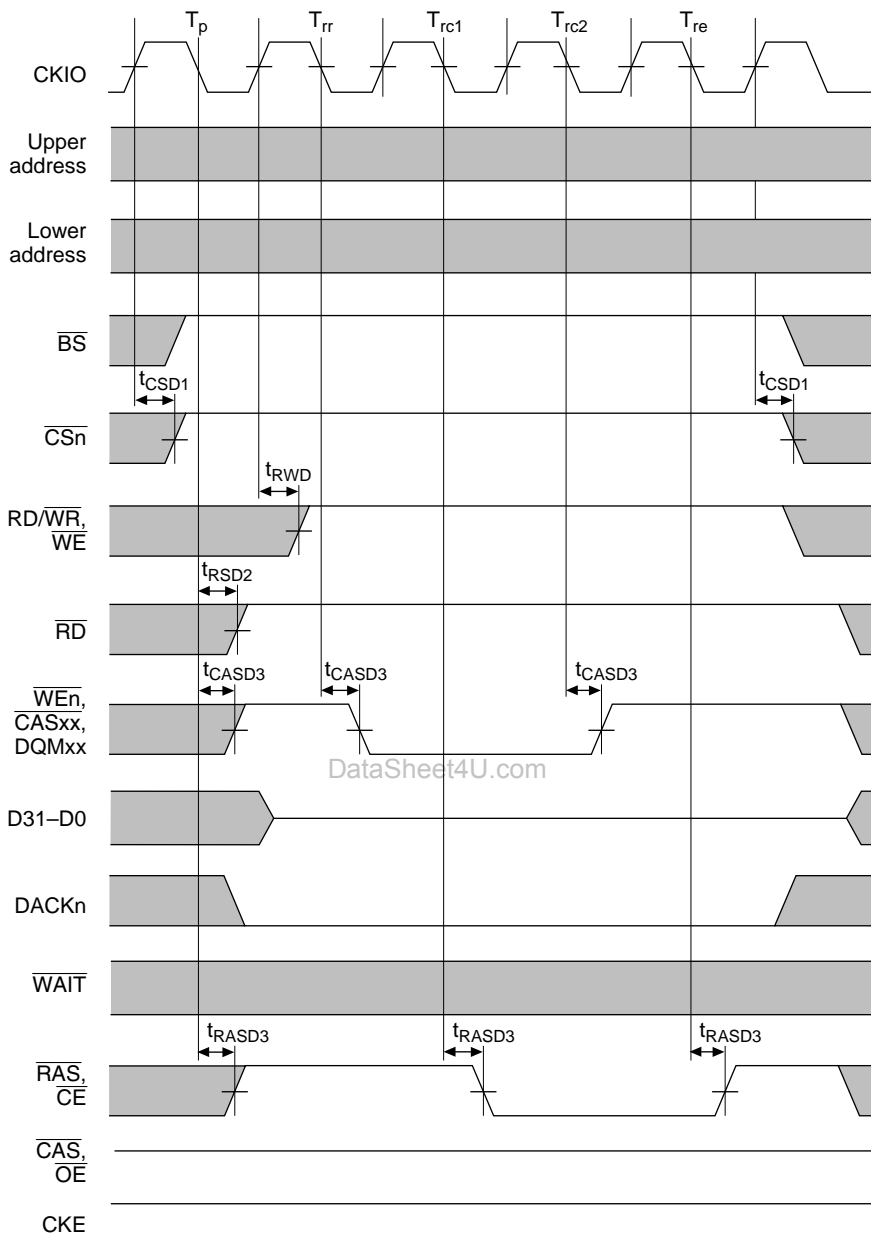
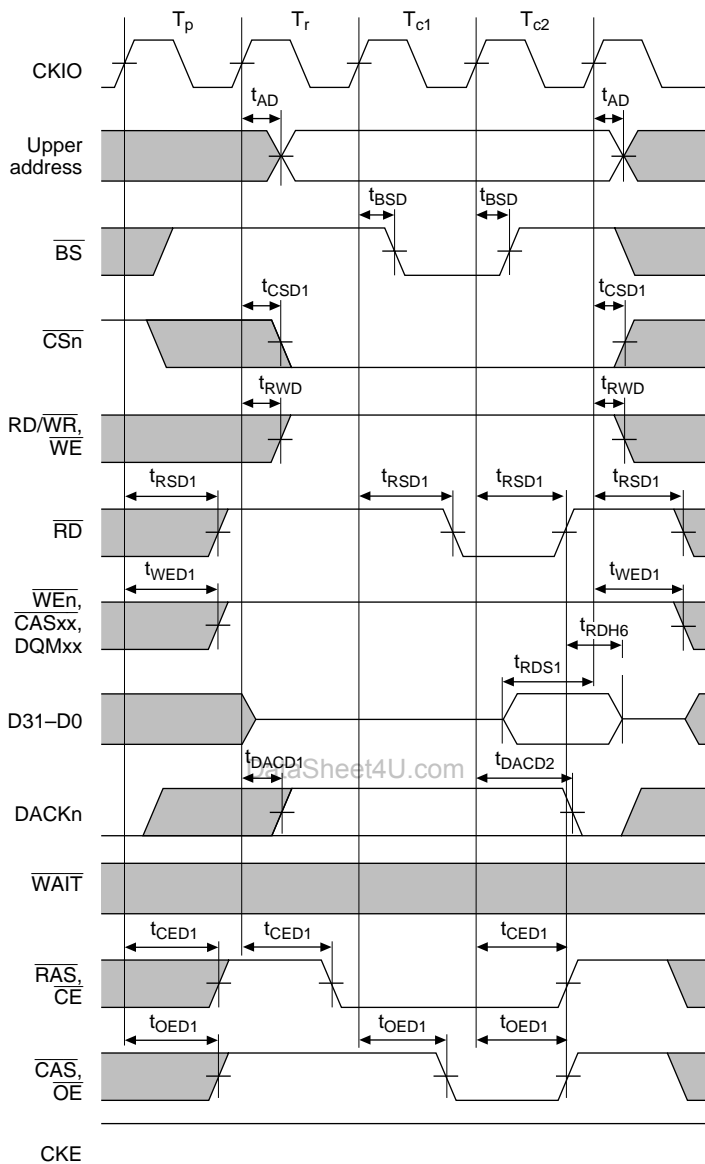
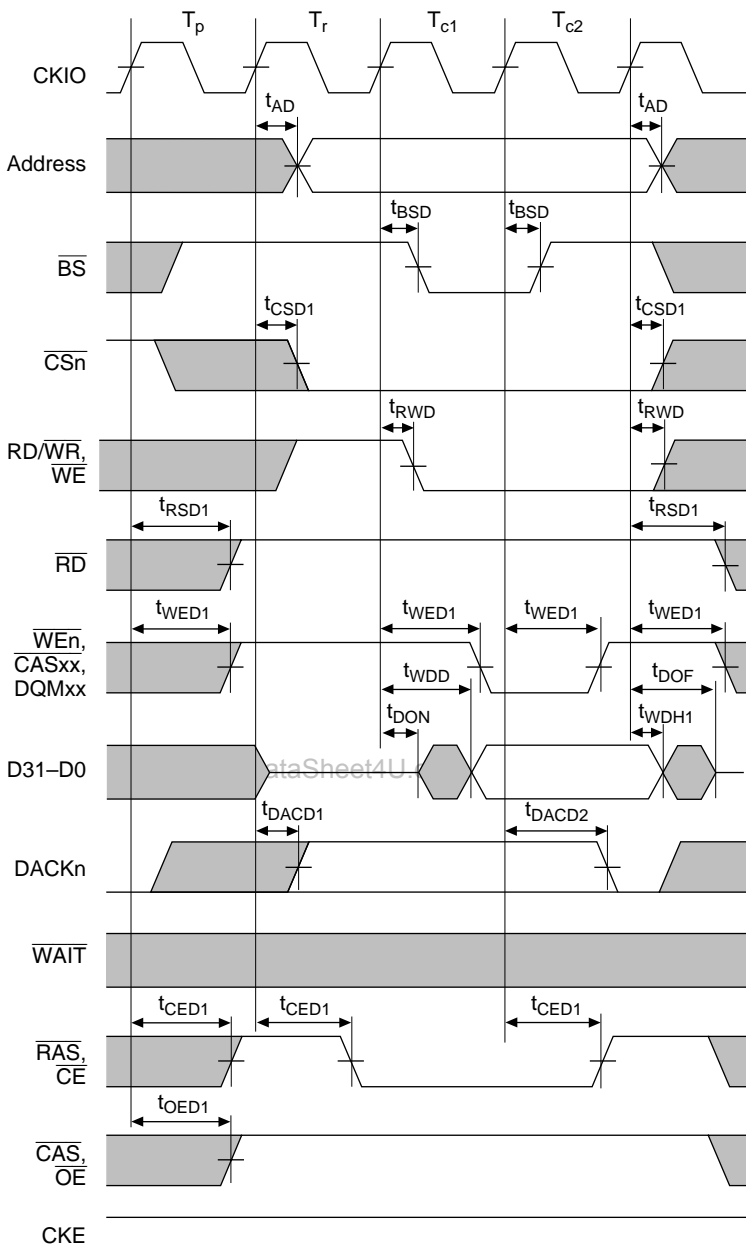

Figure 16.51 DRAM CAS-Before-RAS Refresh Cycle
(TRP = 1 Cycle, TRAS = 2 Cycles, PLL Off)



Note: The DACKn waveform shown is for the case where active-high has been specified.

Figure 16.52 Pseudo-SRAM Read Cycle
(PLL On, TRP = 1 Cycle, RCD = 1 Cycle, No Waits)



Note: The DACKn waveform shown is for the case where active-high has been specified.

Figure 16.53 Pseudo-SRAM Write Cycle
 (PLL On, TRP = 1 Cycle, RCD = 1 Cycle, No Waits)

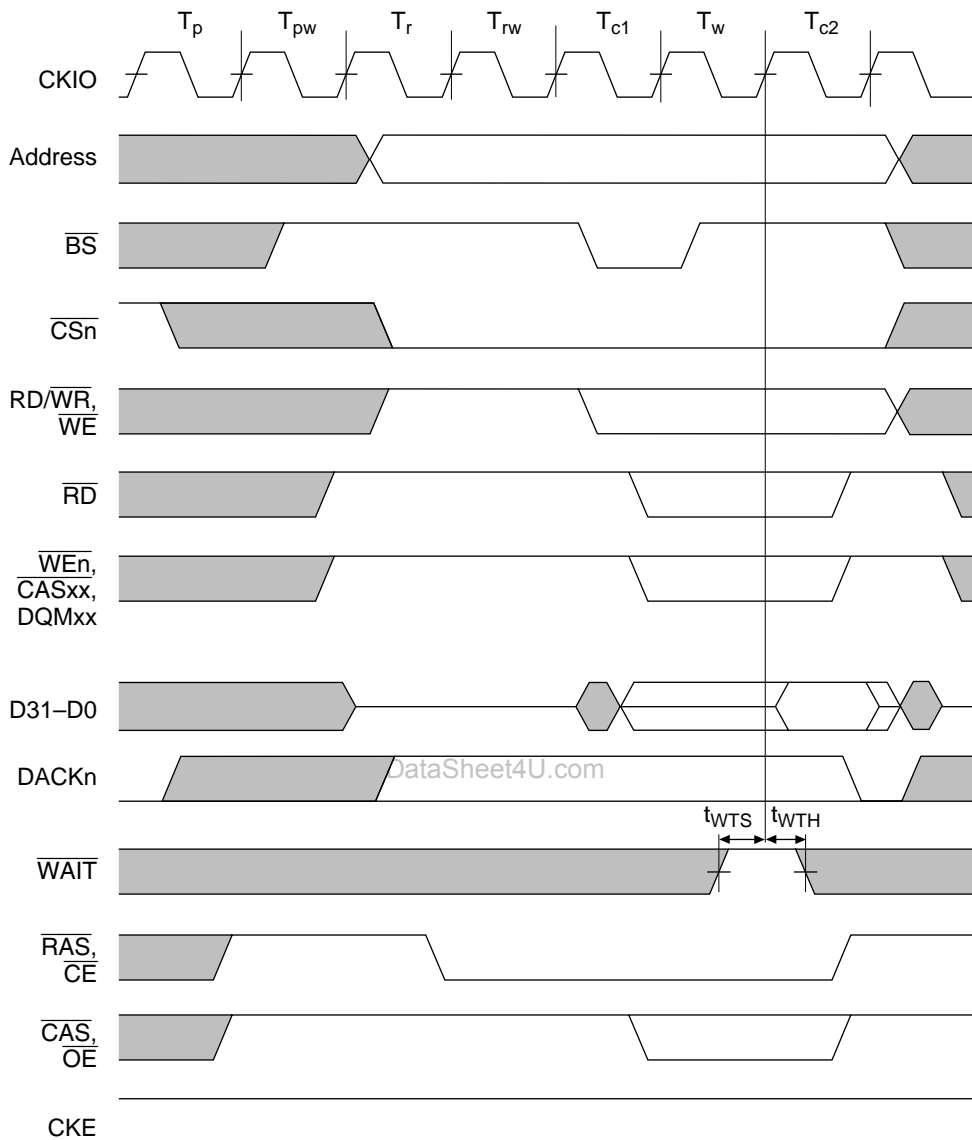

Note: The DACKn waveform shown is for the case where active-high has been specified.

Figure 16.54 Pseudo-SRAM Bus Cycle (TRP = 2 Cycles, RCD = 2 Cycles, 1 Wait)

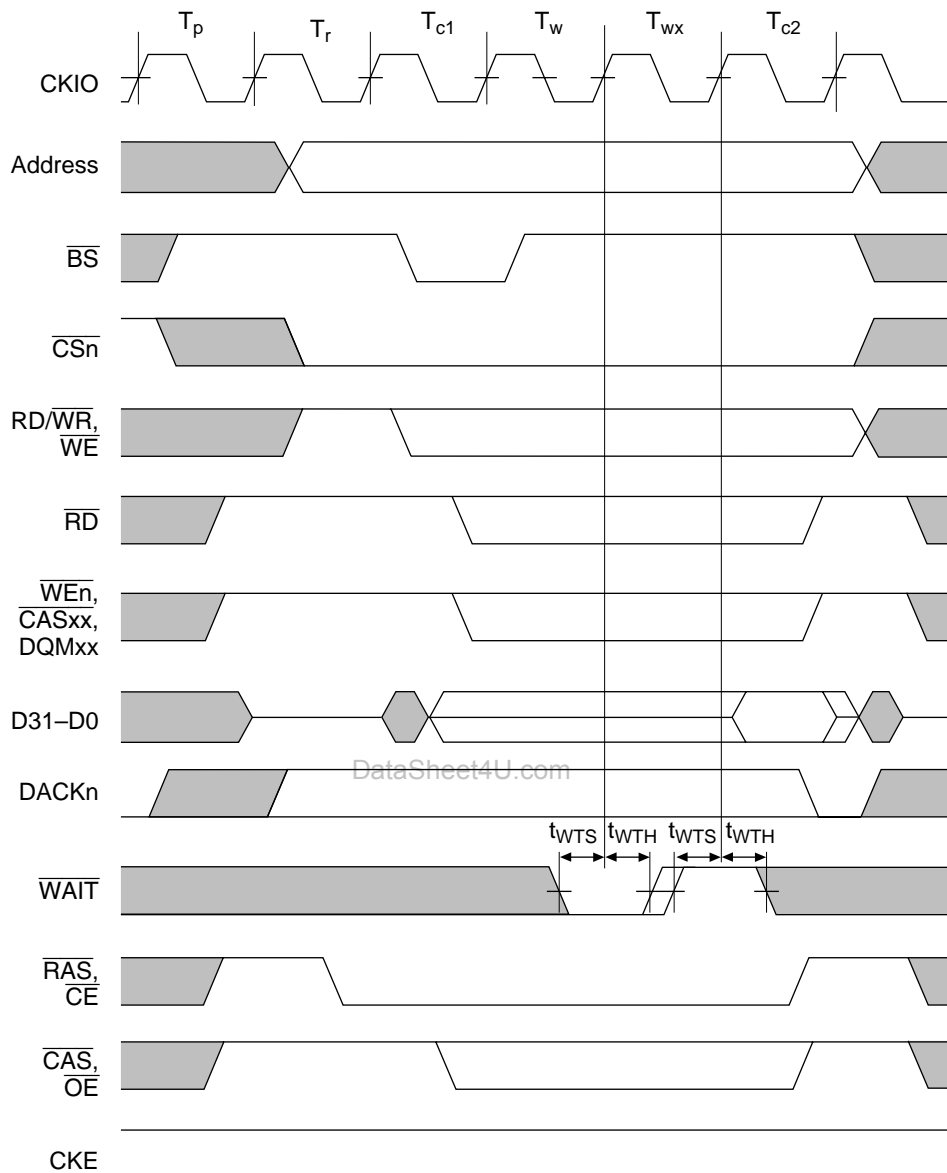

Note: The DACKn waveform shown is for the case where active-high has been specified.

Figure 16.55 Pseudo-SRAM Bus Cycle
 (TRP = 1 Cycle, RCD = 1 Cycle, External Wait Input)

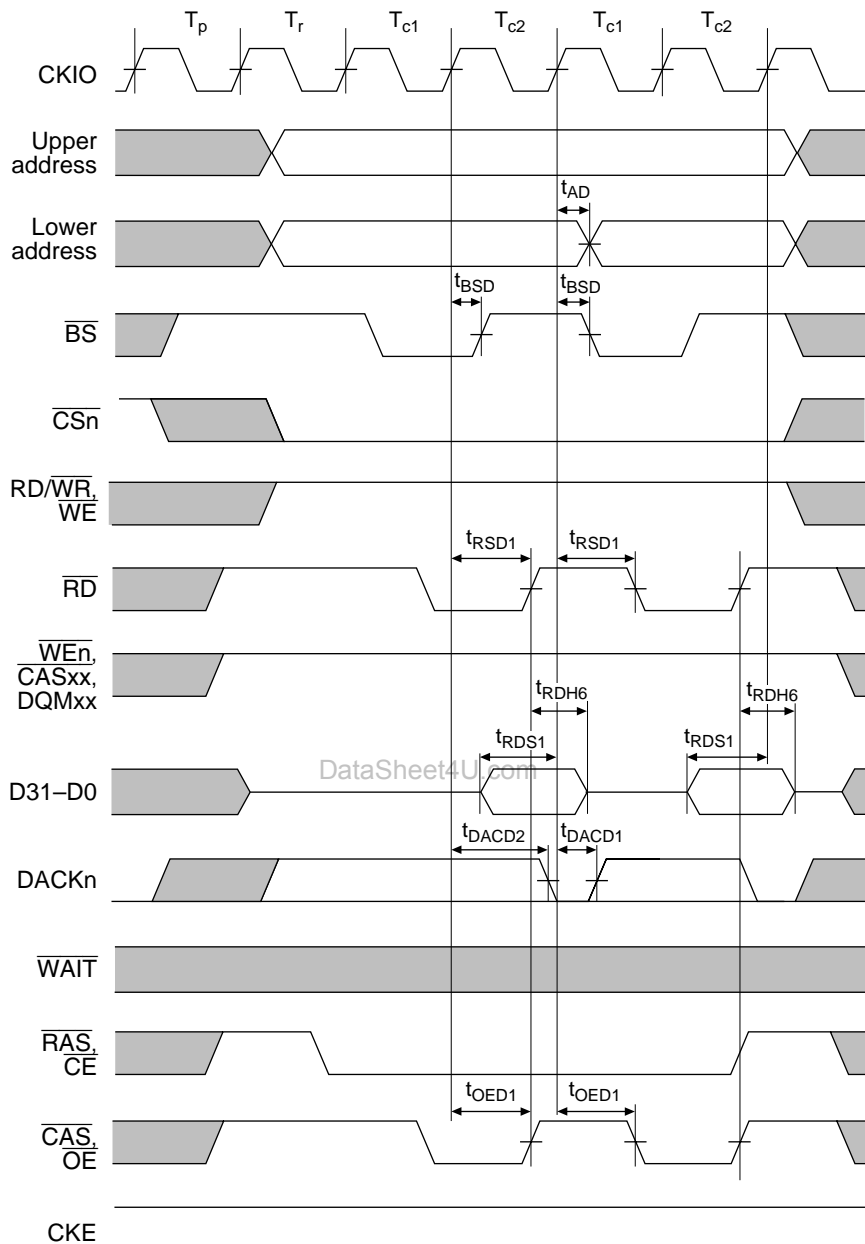

Note: The DACKn waveform shown is for the case where active-high has been specified.

Figure 16.56 Pseudo-SRAM Read Cycle
 (Static Column Mode, PLL On, TRP = 1 Cycle, RCD = 1 Cycle, No Waits)

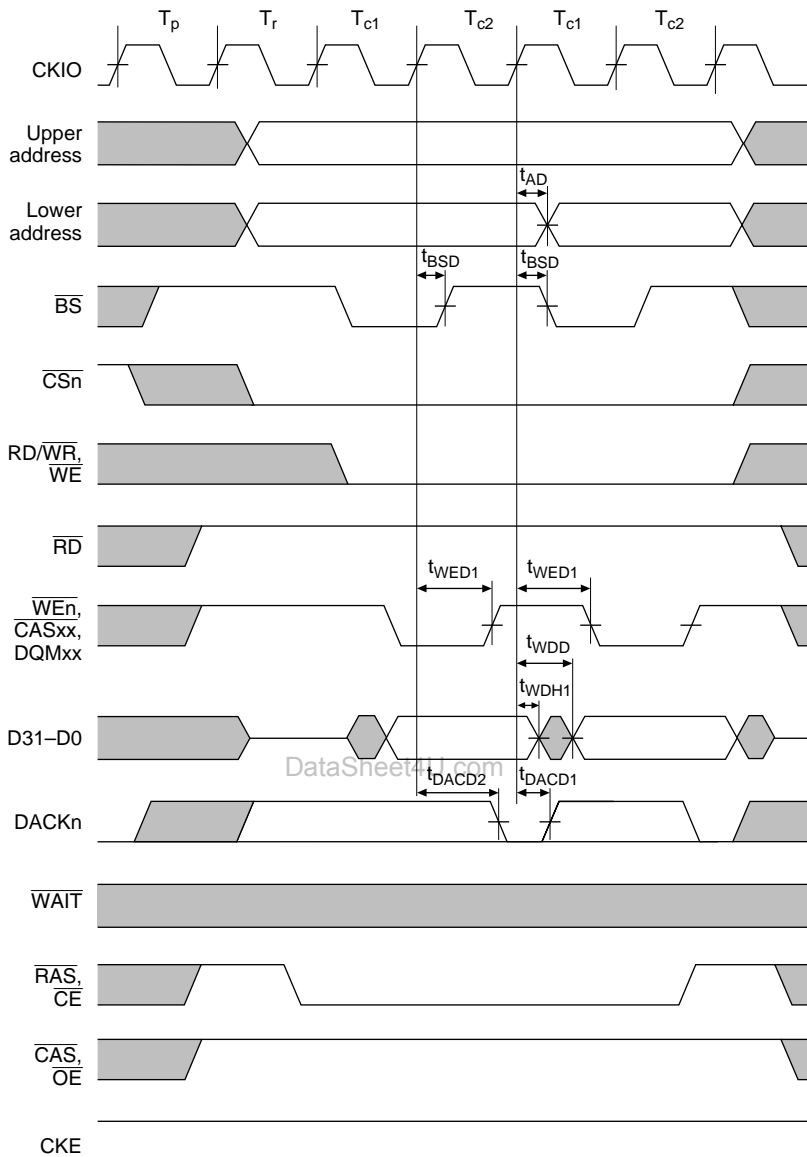

Note: The DACKn waveform shown is for the case where active-high has been specified.

Figure 16.57 Pseudo-SRAM Write Cycle
(Static Column Mode, PLL On, TRP = 1 Cycle, RCD = 1 Cycle, No Waits)

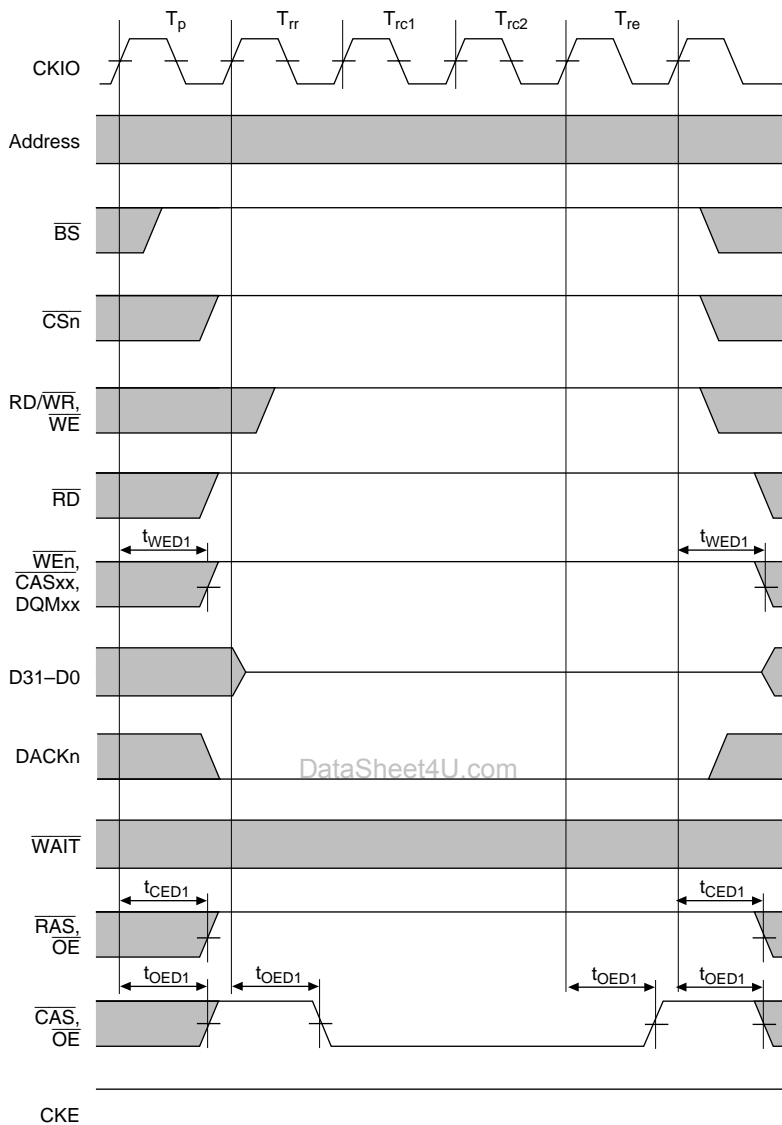

**Figure 16.58 Pseudo-SRAM Auto-Refresh Cycle
(PLL On, TRP = 1 Cycle, TRAS = 2 Cycles)**

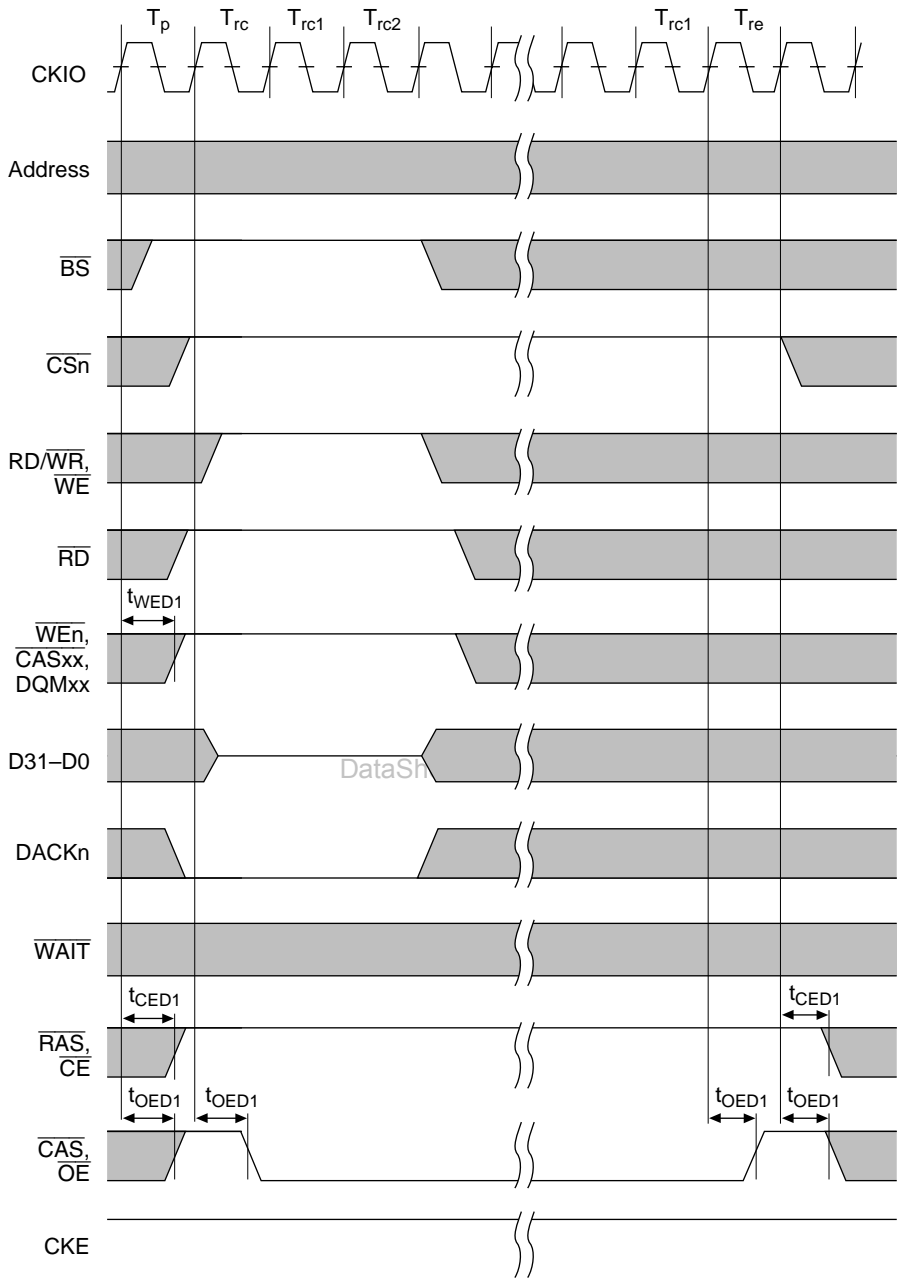
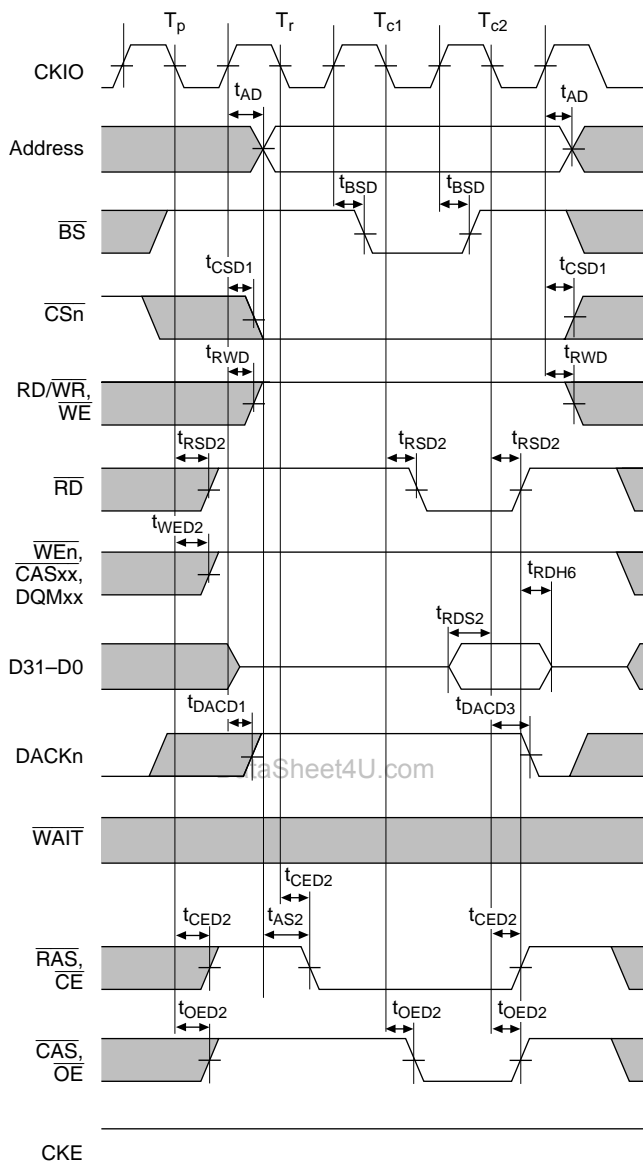
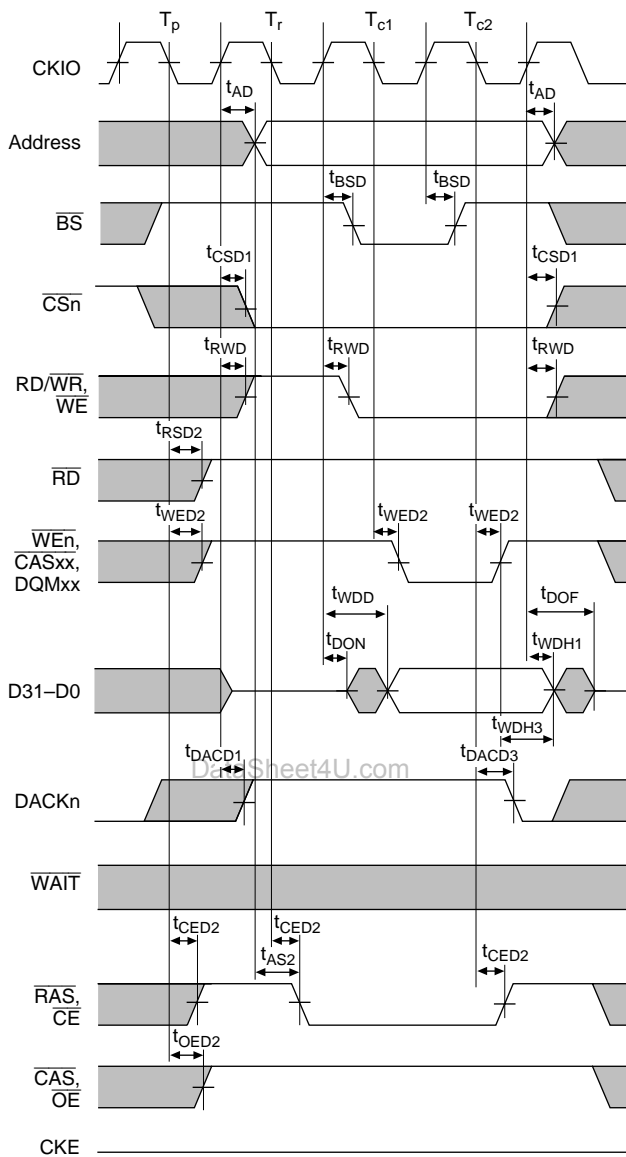

Figure 16.59 Pseudo-SRAM Self-Refresh Cycle
 (PLL On, TRP = 1 Cycle, TRAS = 2 Cycles)



Note: The DACKn waveform shown is for the case where active-high has been specified.

Figure 16.60 Pseudo-SRAM Read Cycle
(PLL Off, TRP = 1 Cycle, RCD = 1 Cycle, No Waits)



Note: The DACKn waveform shown is for the case where active-high has been specified.

Figure 16.61 Pseudo-SRAM Write Cycle
(PLL Off, TRP = 1 Cycle, RCD = 1 Cycle, No Waits)

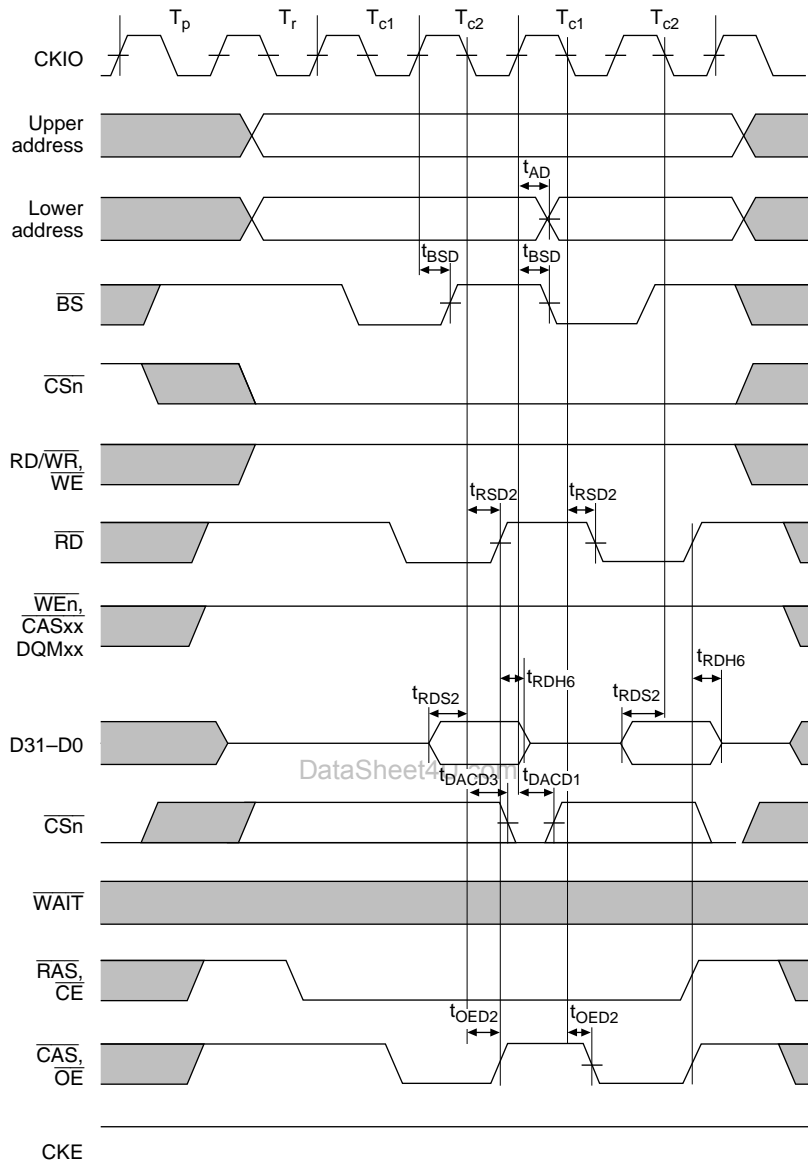

Note: The DACKn waveform shown is for the case where active-high has been specified.

Figure 16.62 Pseudo-SRAM Read Cycle
 (Static Column Mode, PLL Off, TRP = 1 Cycle, RCD = 1 Cycle, No Waits)

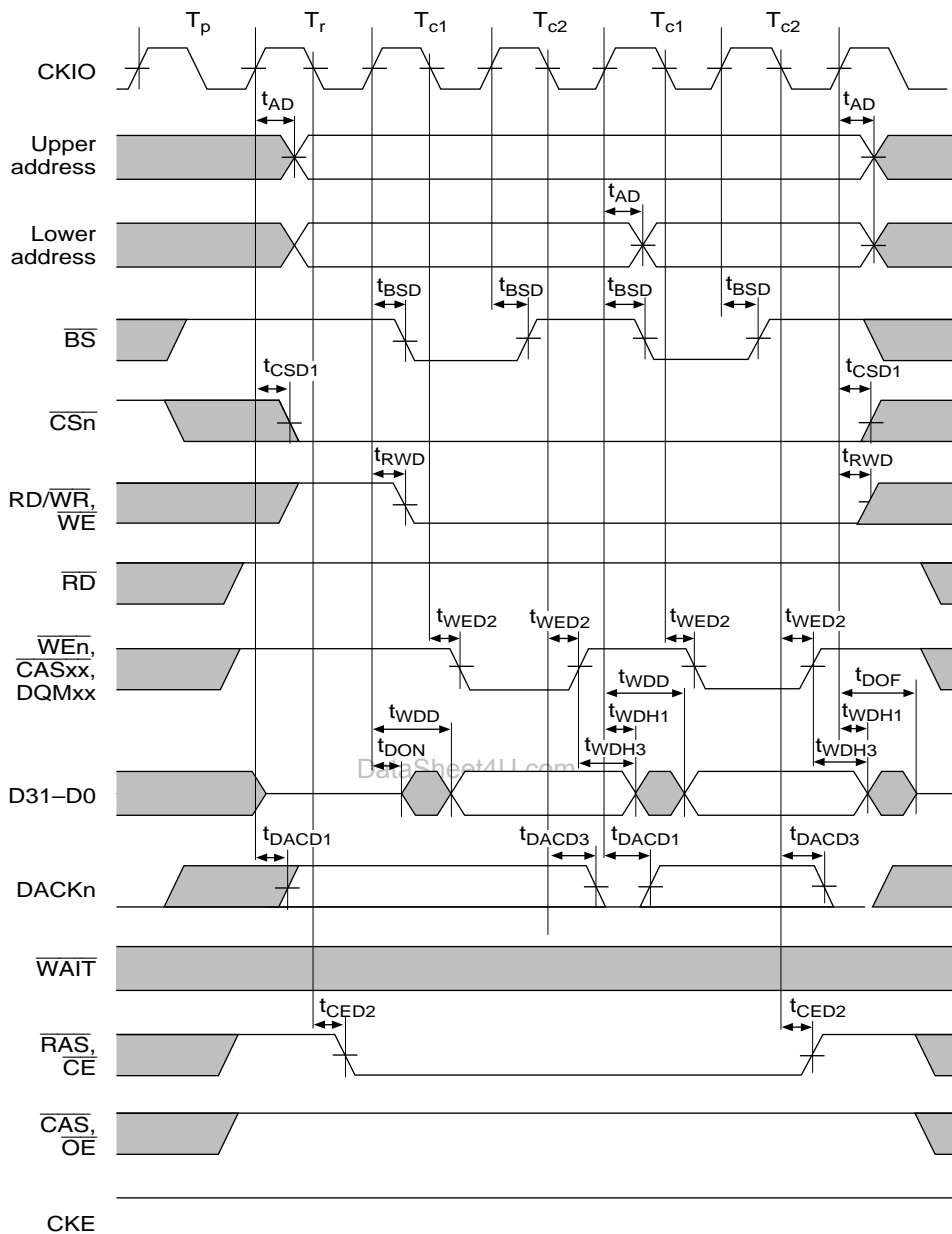

Note: The DACKn waveform shown is for the case where active-high has been specified.

Figure 16.63 Pseudo-SRAM Write Cycle
(Static Column Mode, PLL Off, TRP = 1 Cycle, RCD = 1 Cycle, No Waits)

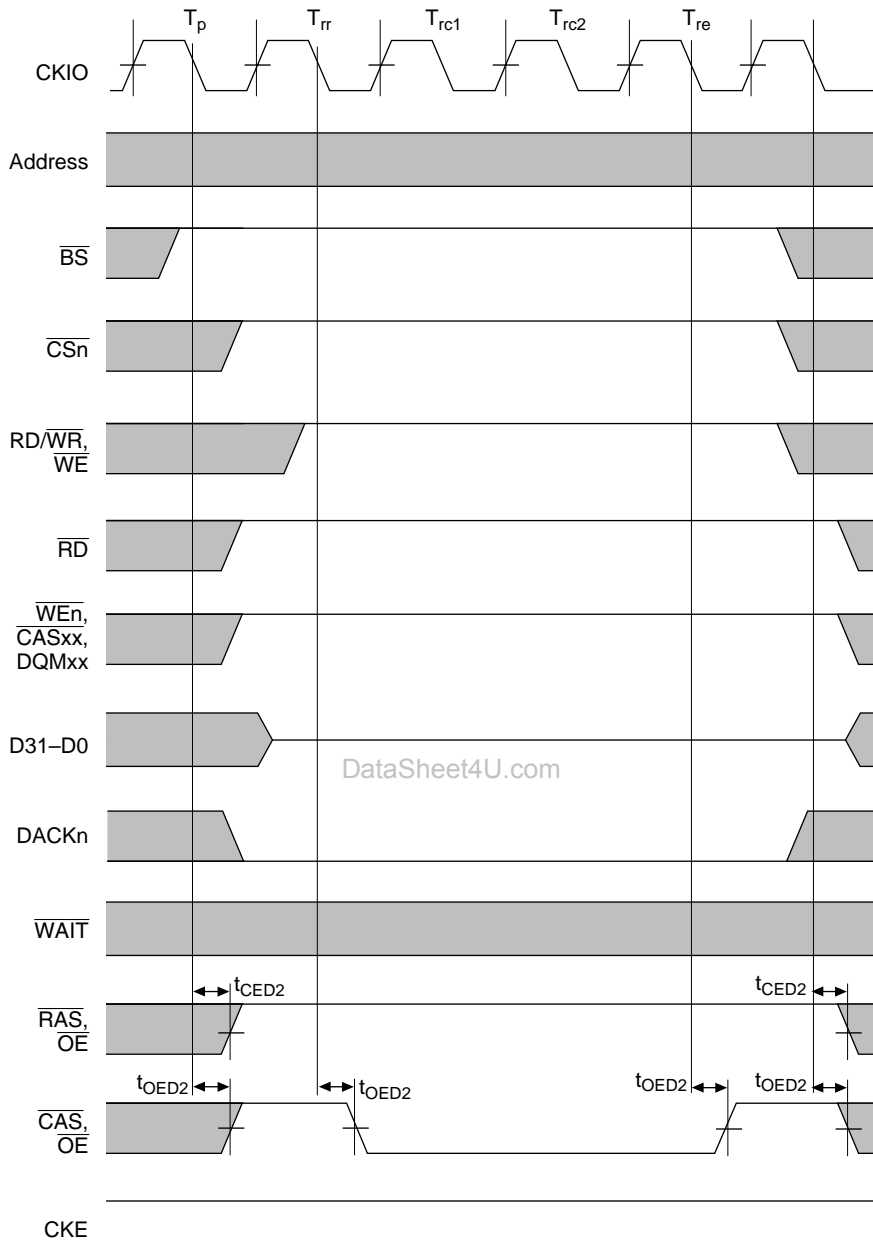

Figure 16.64 Pseudo-SRAM Auto-Refresh Cycle
(PLL Off, TRP = 1 Cycle, TRAS = 2 Cycles)

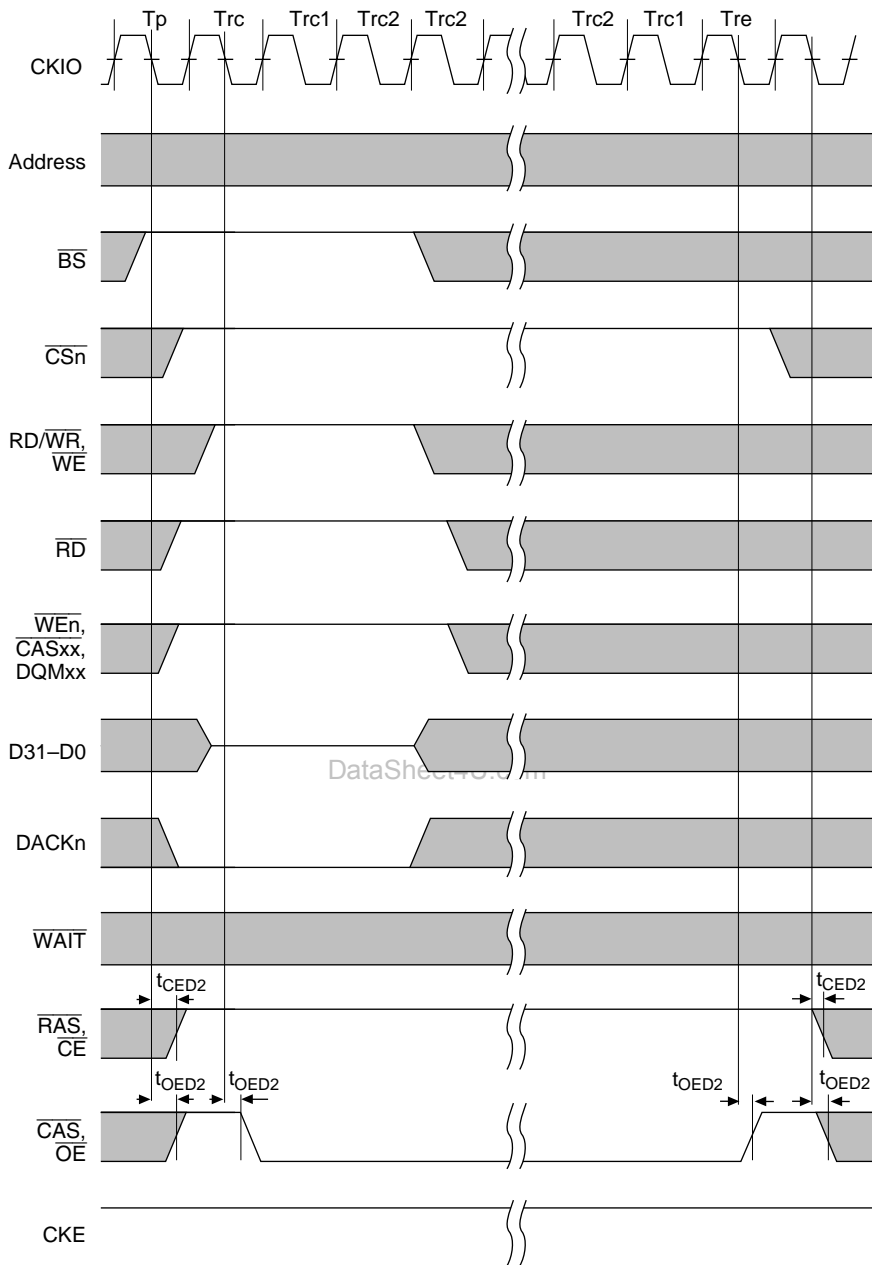
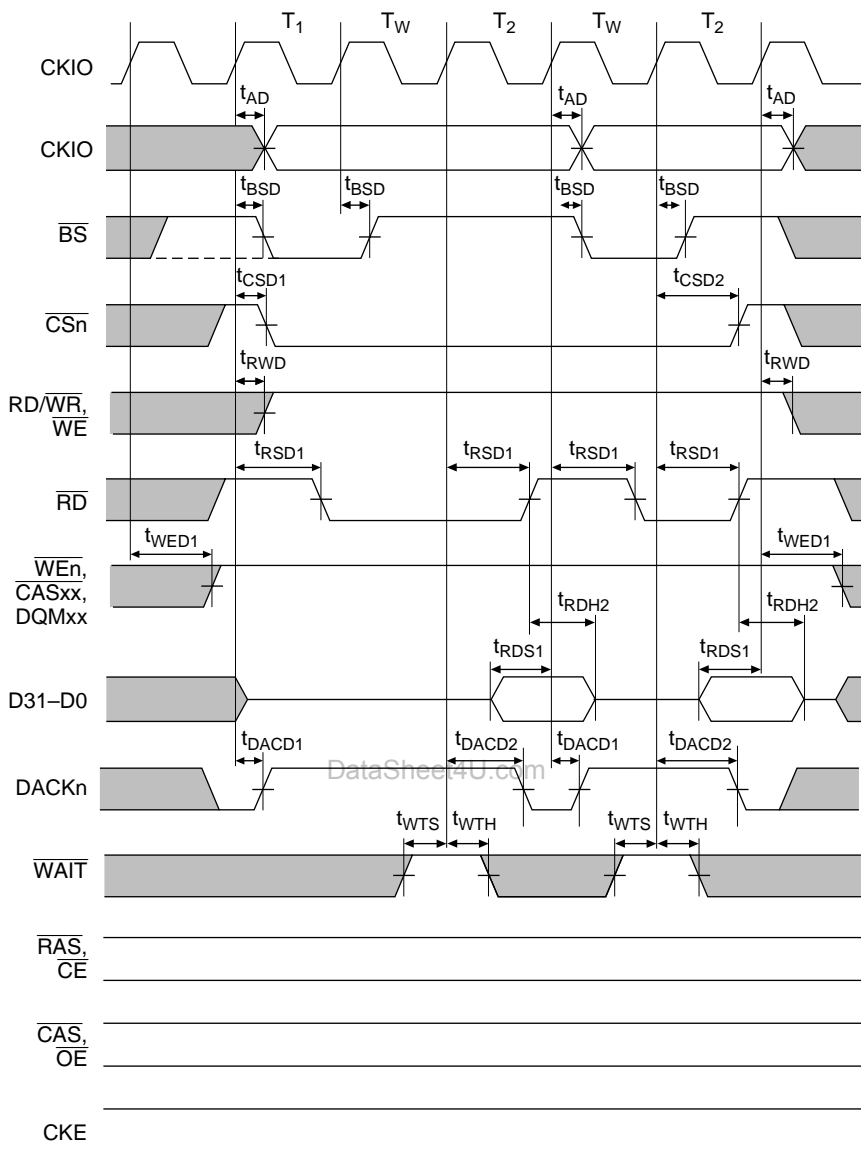
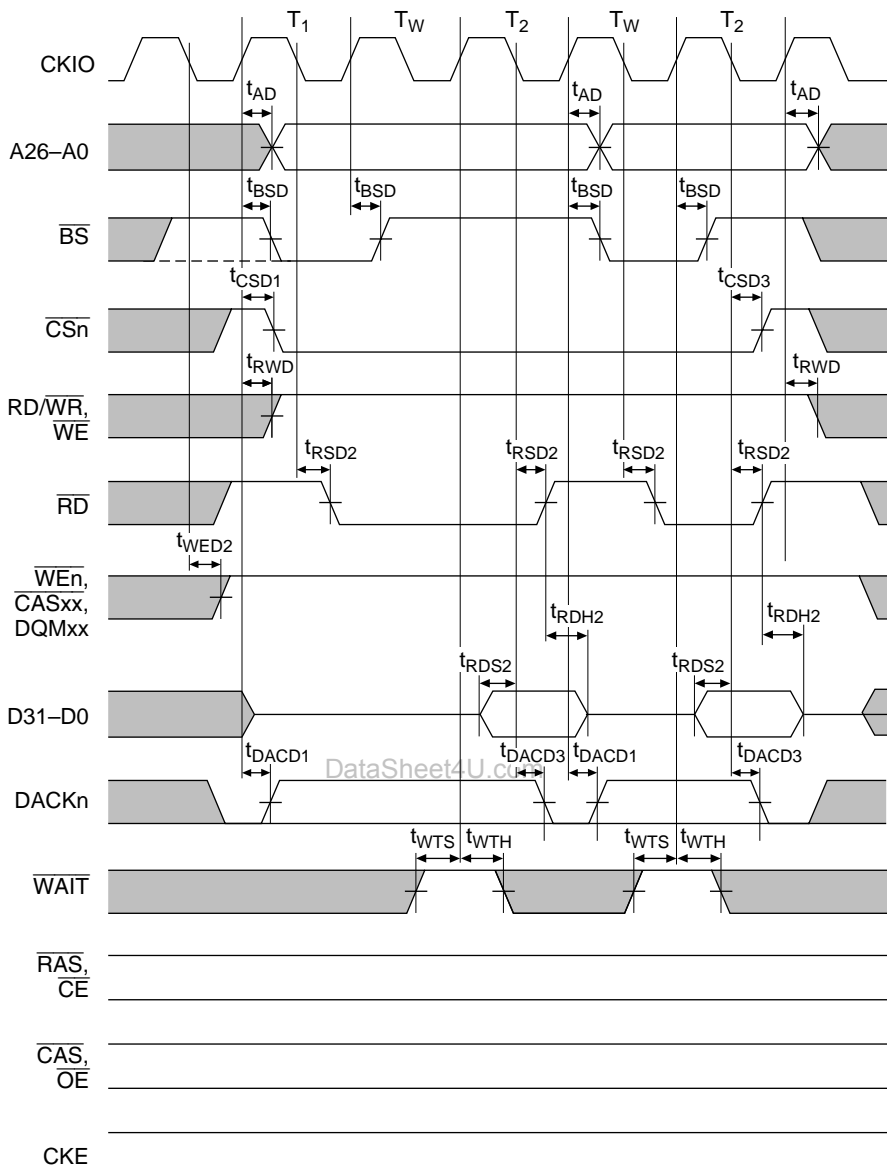

Figure 16.65 Pseudo-SRAM Self-Refresh Cycle
 (PLL Off, TRP = 1 Cycle, TRAS = 2 Cycles)



Note: The DACK_n waveform shown is for the case where active-high has been specified.

Figure 16.66 Burst ROM Read Cycle (PLL On, 1 Wait)



Note: The DACKn waveform shown is for the case where active-high has been specified.

Figure 16.67 Burst ROM Read Cycle (PLL Off, 1 Wait)

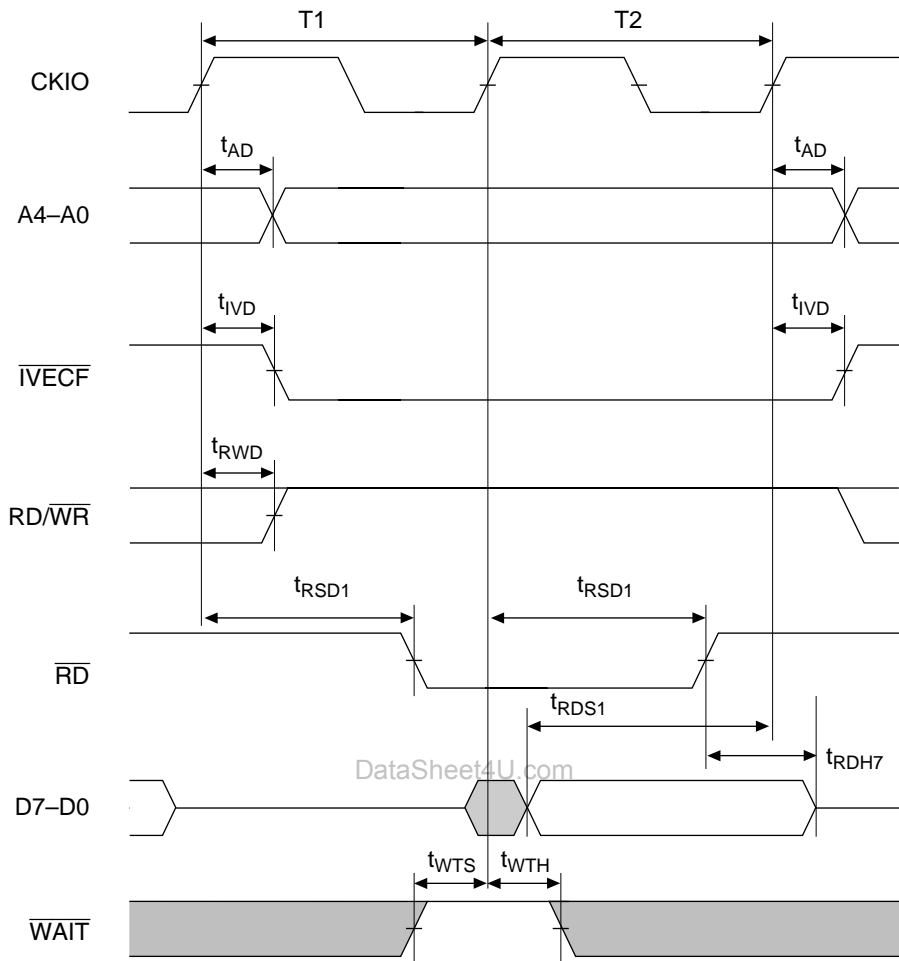

Figure 16.68 Interrupt Vector Fetch Cycle (PLL On, No Waits)

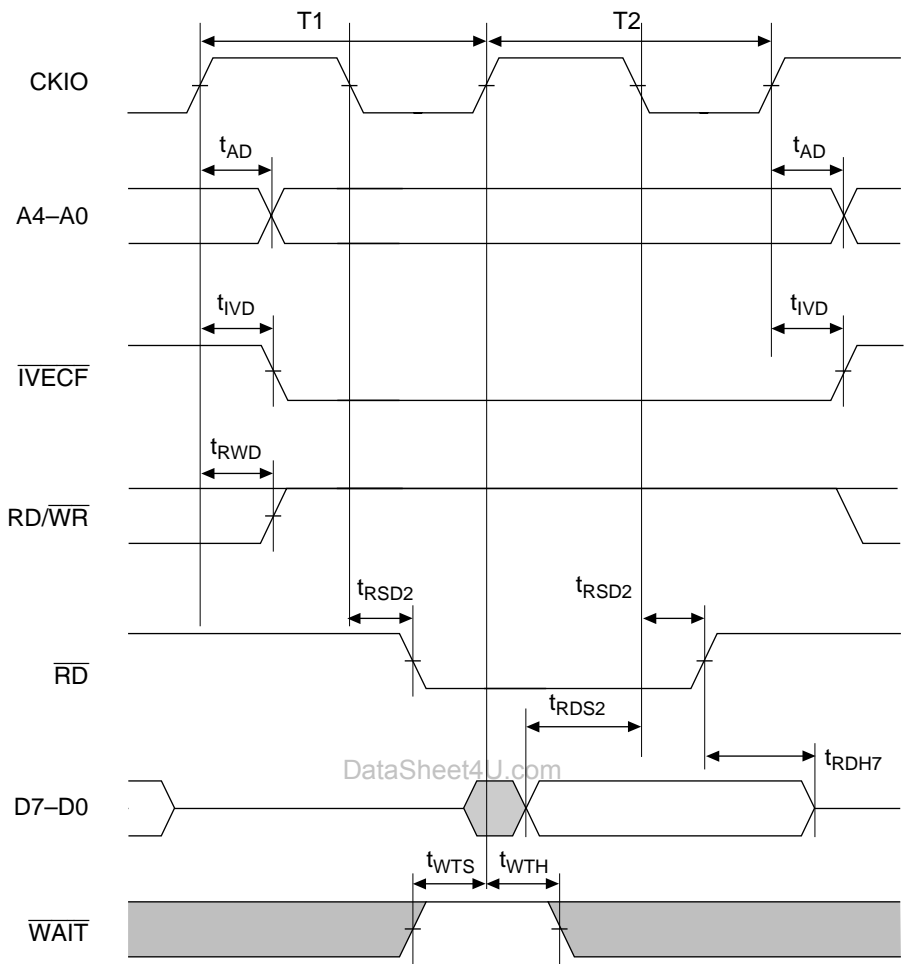

Figure 16.69 Interrupt Vector Fetch Cycle (PLL Off, No Waits)

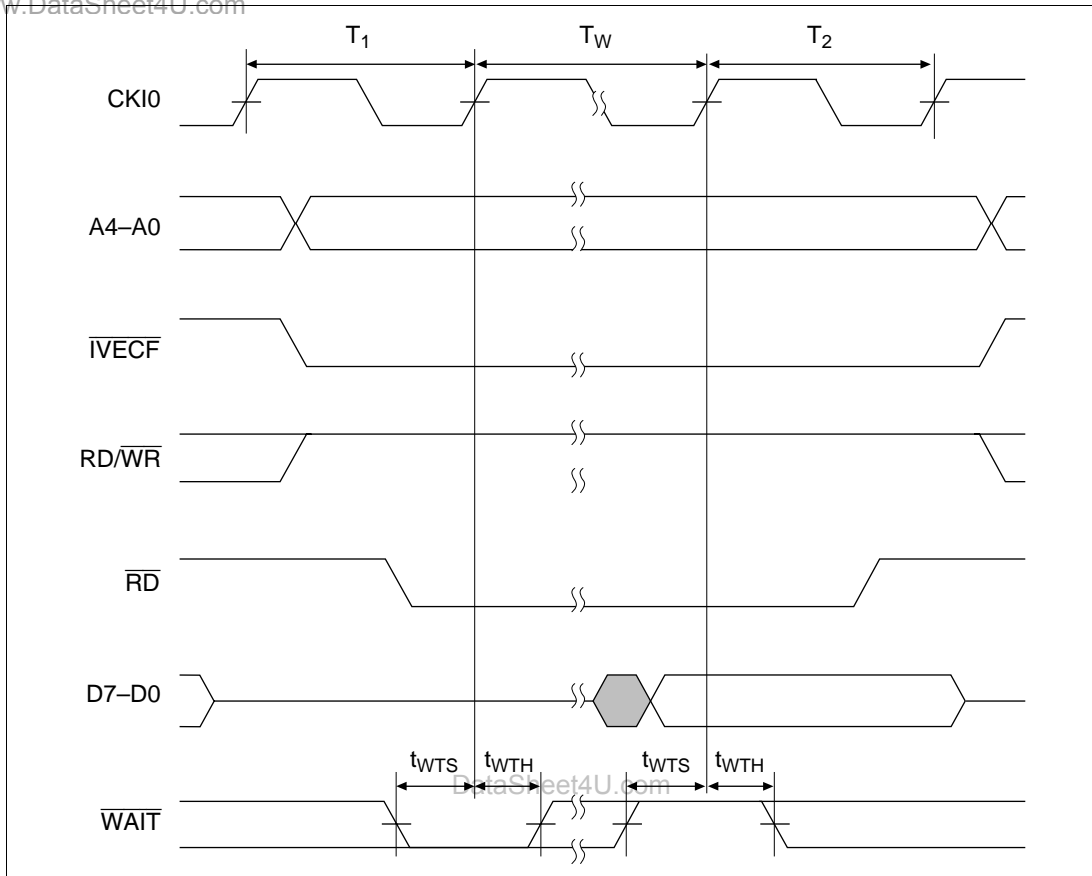

Figure 16.70 Interrupt Vector Fetch Cycle (1 External Wait Cycle)

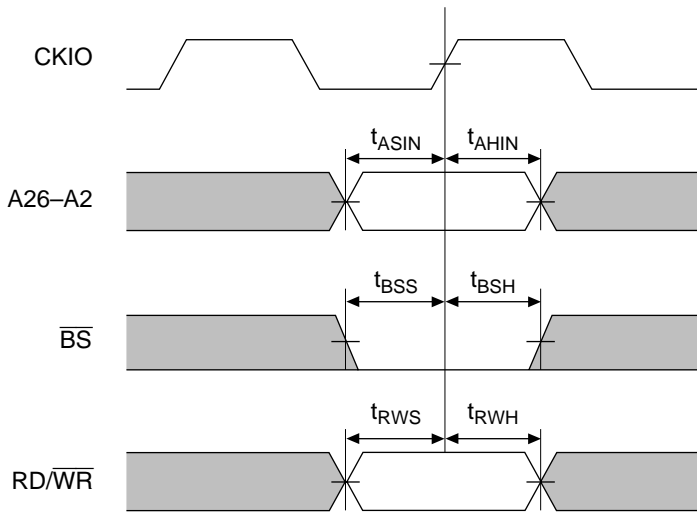

Figure 16.71 Address Monitor Cycle

Table 16.10 DMAC Timing (Conditions: $V_{CC} = 3.0$ to 5.5 V, $T_a = -20$ to $+75^{\circ}\text{C}$)

Item	Symbol	Min	Max	Unit	Figure
DREQ0, DREQ1 setup time (PLL Off, On)	t_{DRQS}	50	—	ns	16.72
DREQ0, DREQ1 setup time (PLL On, 1/4 cycle delay)	t_{DRQS}	$50 - 1/4 t_{cyc}$	—	ns	
DREQ0, DREQ1 hold time (PLL Off, On)	t_{DRQH}	50	—	ns	
DREQ0, DREQ1 hold time (PLL On, 1/4 cycle delay)	t_{DRQH}	$1/4 t_{cyc} + 50$	—	ns	
DREQ0, DREQ1 low level width	t_{DRQW}	1.5	—	t_{cyc}	

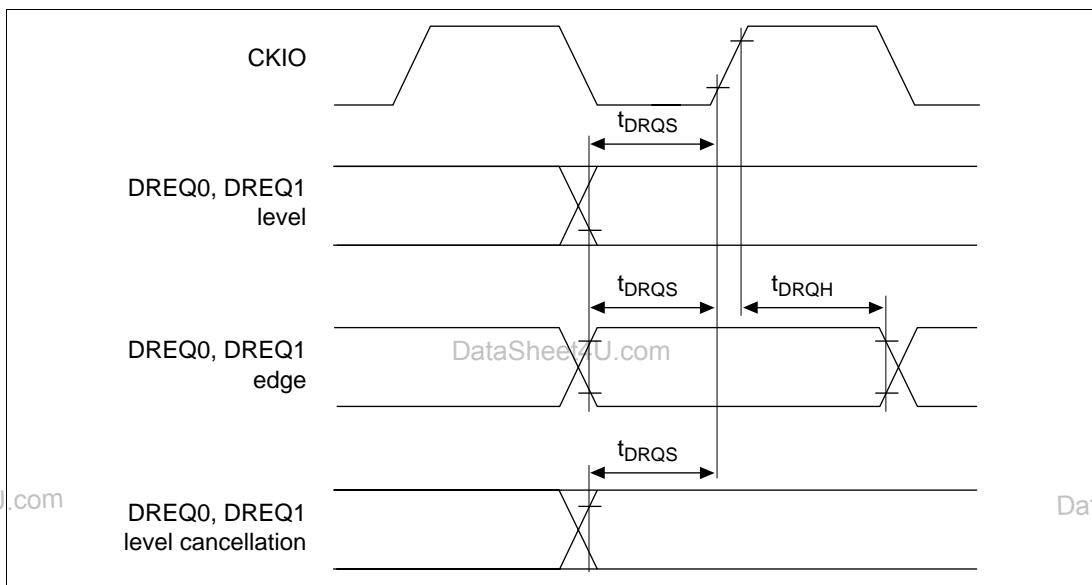

Figure 16.72 DREQ0, DREQ1 Input Timing

16.3.5 Free-Running Timer Timing

Table 16.11 Free-Running Timer Timing (Conditions: $V_{CC} = 3.0$ to 5.5 V, $T_a = -20$ to $+75^\circ\text{C}$)

Item	Symbol	Min	Max	Unit	Figure
Output compare output delay time (PLL Off, On)	t_{TOCD}	—	320	ns	16.73
Output compare output delay time (PLL On, 1/4 cycle delay)	t_{TOCD}	—	$1/4 t_{cyc} + 320$	ns	
Input capture input setup time (PLL Off, On)	t_{TICS}	80	—	ns	
Input capture input setup time (PLL On, 1/4 cycle delay)	t_{TICS}	$80 - 1/4 t_{cyc}$	—	ns	
Timer clock input setup time (PLL Off, On)	t_{TCKS}	80	—	ns	16.74
Timer clock input setup time (PLL On, 1/4 cycle delay)	t_{TCKS}	$80 - 1/4 t_{cyc}$	—	ns	
Timer clock pulse width (single edge)	t_{TCKWH}	4.5	—	t_{cyc}	
Timer clock pulse width (both edges)	t_{TCKWL}	8.5	—	t_{cyc}	

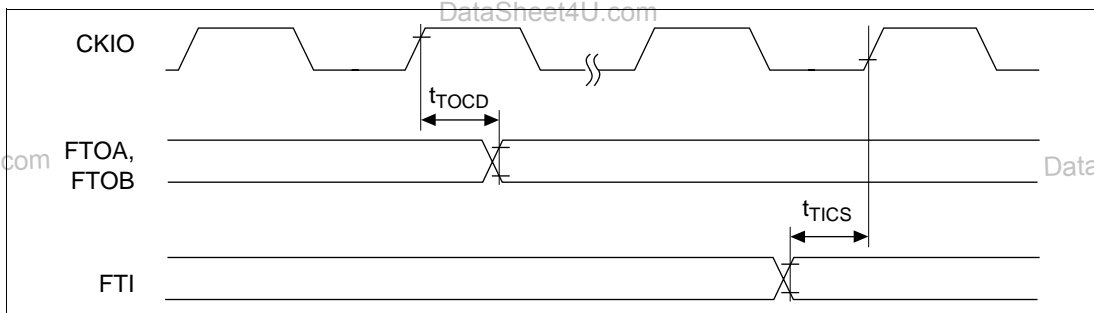

Figure 16.73 FRT Input/Output Timing

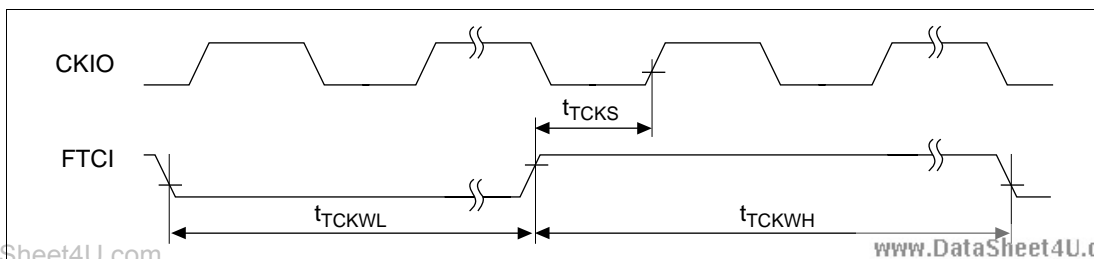

Figure 16.74 FRT Clock Input Timing

16.3.6 Watchdog Timer Timing

Table 16.12 Watchdog Timer Timing (Conditions: $V_{CC} = 3.0$ to 5.5 V, $T_a = -20$ to $+75^{\circ}\text{C}$)

Item	Symbol	Min	Max	Unit	Figure
WDTOVF delay time (PLL Off, On)	t_{WOVD}	—	70	ns	16.75
WDTOVF delay time (PLL On, 1/4 cycle delay)	t_{WOVD}	—	$1/4 \text{ tcyc} + 70$	ns	

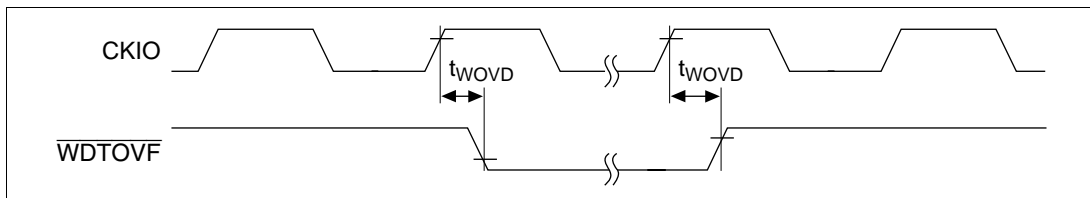

Figure 16.75 Watchdog Timer Output Timing

DataSheet4U.com

et4U.com

DataShee

DataSheet4U.com

www.DataSheet4U.com

16.3.7 Serial Communication Interface Timing

Table 16.13 Serial Communication Interface Timing

 (Conditions: $V_{CC} = 3.0$ to 5.5 V, $T_a = -20$ to $+75^{\circ}\text{C}$)

Item	Symbol	Min	Max	Unit	Figure
Input clock cycle	t_{scyc}	16	—	t_{cyc}	16.76
Input clock cycle (clocked synchronous mode)	t_{scyc}	24	—	t_{cyc}	
Input clock pulse width	t_{sckw}	0.4	0.6	t_{scyc}	
Transmission data delay time (clocked synchronous mode)	t_{TXD}	—	70	ns	16.77
Receive data setup time (clocked synchronous mode)	t_{RXS}	70	—	ns	
Receive data hold time (clocked synchronous mode)	t_{RXH}	70	—	ns	

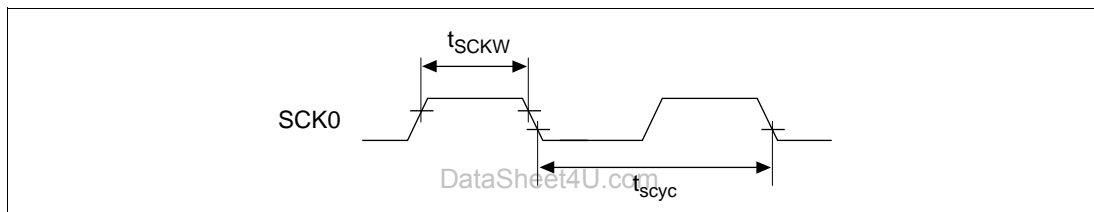
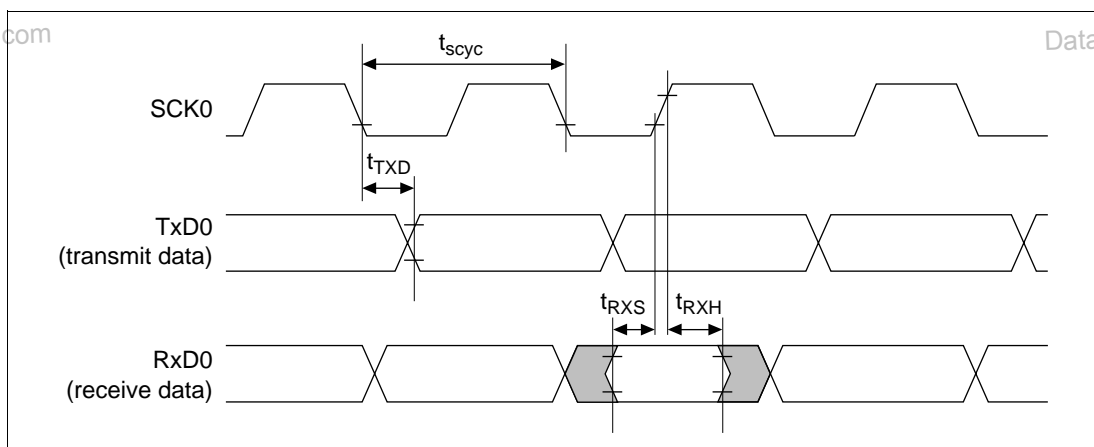
Figure 16.76 Input Clock Input/Output Timing

Figure 16.77 SCI Input/Output Timing (Clocked Synchronous Mode)

16.3.8 AC Characteristics Measurement Conditions

- I/O signal reference level: 1.5 V
- Input pulse level: V_{SS} to 3.0 V (where RES, NMI, CKIO and MD5-MD0 are within the range V_{SS} to V_{CC})
- Input rise and fall times: 1 ns

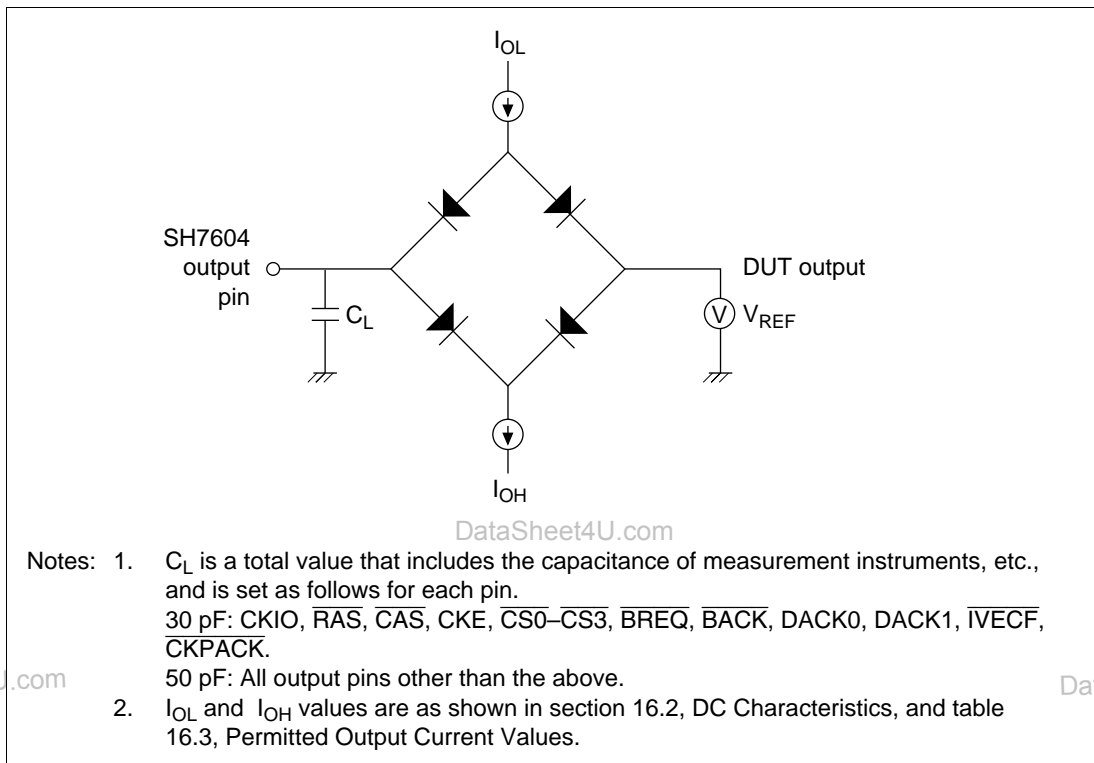

Figure 16.78 Output Load Circuit

Appendix A Pin States

Table A.1 Pin States During Resets, Power-Down State, and Bus-Released State

Category	Pin	Pin States						
		Reset Power-On		Reset Manual		Power-Down Modes		Bus-Released Mode
		Master	Slave	Bus Acquired	Bus Released	Standby	Sleep	
Clock	CKIO	IO^{*1}	IO^{*1}	IO^{*1}	IO^{*1}	IO^{*1}	IO^{*1}	IO^{*1}
	EXTAL	I^{*1}	I^{*1}	I^{*1}	I^{*1}	I^{*1}	I^{*1}	I^{*1}
	XTAL	O^{*1}	O^{*1}	O^{*1}	O^{*1}	O^{*1}	O^{*1}	O^{*1}
	\overline{CKPREQ}	Z	Z	I	I	I	I	I
	\overline{CKPACK}	H	H	H	H	H^{*2}	H	H
	System control	\overline{RESET}	I	I	I	I	I	I
\overline{WDTOVF}		H	H	H	H	O	O	O
\overline{BACK} , \overline{BRLS}		Z	Z	I	I	Z	I	I
\overline{BREQ} , \overline{BGR}		H	H	O	O	H	O	O
MD5–MD0		I	I	I	I	I	I	I
Interrupt	NMI	I	I	I	I	I	I	I
	$\overline{IRL3}$ – $\overline{IRL0}$	Z	Z	Z	Z	I	I	I
	\overline{IVECF}	H	H	H	H	H^{*3}	H	H
Address bus	A26–A0	O	Z	O	Z	Z	O	Z^{*4}
Data bus	D31–D0	Z	Z	IO	Z	Z	Z	Z
Bus control	$\overline{CS3}$ – $\overline{CS0}$	H	Z	O	Z	H	H	Z^{*4}
	\overline{BS}	H	Z	O	Z	H	H	Z
	\overline{RD} / \overline{WR}	H	Z	O	Z	H	H	Z^{*4}
	\overline{RAS} , \overline{CE}	H	Z	O	Z	H	H	Z
	\overline{CAS} , \overline{OE}	H	Z	O	Z	H	H	Z
	\overline{CASHH} , \overline{DQMUU}	H	Z	O	Z	H	H	Z
	\overline{CASHL} , \overline{DQMUL}	H	Z	O	Z	H	H	Z
	\overline{CASLH} , \overline{DQMLU}	H	Z	O	Z	H	H	Z
	\overline{CASLL} , \overline{DQMLL}	H	Z	O	Z	H	H	Z
	\overline{RD}	H	Z	O	Z	H	H	Z
	CKE	H	H	O	H	O	O	H
	\overline{WAIT}	Z	Z	I	Z	Z	I	Ignored

Table A.1 Pin States During Resets, Power-Down State, and Bus-Released State (cont)

Category	Pin	Pin States						
		Reset Power-On		Reset Manual		Power-Down Modes		Bus-Released Mode
		Master	Slave	Bus Acquired	Bus Released	Standby	Sleep	
Direct memory access controller (DMAC)	DACK0, DACK1	H	H	H	H	K ³	O	O
	DREQ0, DREQ1	Z	Z	Z	Z	Z	I	I
16-bit free-running timer (FRT)	FTOA	L	L	L	L	K ³	O	O
	FTOB	L	L	L	L	K ³	O	O
	FTI	Z	Z	Z	Z	K ³	I	I
	FTCI	Z	Z	Z	Z	K ³	I	I
Serial communication interface (SCI)	RXD	Z	Z	Z	Z	K ³	I	I
	TXD	H	H	H	H	K ³	O	O
	SCK	Z	Z	Z	Z	K ³	IO	I

I: Input

O: Output

H: High-level output

L: Low-level output

Z: High impedance

K: Input pins are high impedance, output pins retain their state

Notes: 1. Depends on the clock mode (MD2–MD0 setting).

2. Low-level output in standby mode when the clock is paused.

3. When the high impedance bit (HIZ) in the standby control register (SBYCR) is set to 1, output pins become high impedance.

4. Input when the external bus cycle address monitor function is used.

Other: In sleep mode, if the DMAC is running, the address/data bus and bus control signals change according to the DMAC operation (the same applies during refreshing).

Appendix B List of Registers

B.1 List of I/O Registers

Address	Abbrevia- tion of Register	Bit Name								Module
		Bit 7	Bit 6	Bit 5	Bit 4	Bit 3	Bit 2	Bit 1	Bit 0	
H'FFFFFFE00	SMR	C/ \bar{A}	CHR	PE	O/ \bar{E}	STOP	MP	CKS1	CKS0	SCI
H'FFFFFFE01	BRR									
H'FFFFFFE02	SCR	TIE	RIE	TE	RE	MPIE	TEIE	CKE1	CKE0	
H'FFFFFFE03	TDR									
H'FFFFFFE04	SSR	TDRE	RDRF	ORER	FER	PER	TEND	MPB	MPBT	
H'FFFFFFE05	RDR									
H'FFFFFFE06 to H'FFFFFFE09	—	—	—	—	—	—	—	—	—	—
H'FFFFFFE10	TIER	ICIE	—	—	—	OCIAE	OCIBE	OVIE	—	FRT
H'FFFFFFE11	FTCSR	ICF	—	—	—	OCFA	OCFB	OVF	CCLRA	
H'FFFFFFE12	FRC									
H'FFFFFFE13	OCRA/B									
H'FFFFFFE14										
H'FFFFFFE15	TCR									
H'FFFFFFE16		IEDGA	—	—	—	—	—	CKS1	CKS0	
H'FFFFFFE17	TOCR	—	—	—	OCRS	—	—	OLVLA	OLVLB	
H'FFFFFFE18	FICR									
H'FFFFFFE19										
H'FFFFFFE20 to H'FFFFFFE59	—	—	—	—	—	—	—	—	—	—
H'FFFFFFE60	IPRB	SCIP3	SCIP2	SCIP1	SCIP0	FRTIP3	FRTIP2	FRTIP1	FRTIP0	INTC
H'FFFFFFE61		—	—	—	—	—	—	—	—	
H'FFFFFFE62	VCRA	—	SERV6	SERV5	SERV4	SERV3	SERV2	SERV1	SERV0	
H'FFFFFFE63		—	SRXV6	SRXV5	SRXV4	SRXV3	SRXV2	SRXV1	SRXV0	
H'FFFFFFE64	VCRB	—	STXV6	STXV5	STXV4	STXV3	STXV2	STXV1	STXV0	
H'FFFFFFE65		—	STEV6	STEV5	STEV4	STEV3	STEV2	STEV1	STEV0	

Address	Abbreviation of Register	Bit Name								Module
		Bit 7	Bit 6	Bit 5	Bit 4	Bit 3	Bit 2	Bit 1	Bit 0	
H'FFFFFFE66	VCRC	—	FICV6	FICV5	FICV4	FICV3	FICV2	FICV1	FICV0	INTC
H'FFFFFFE67		—	FOCV6	FOCV5	FOCV4	FOCV3	FOCV2	FOCV1	FOCV0	
H'FFFFFFE68	VCRD	—	FOVV6	FOVV5	FOVV4	FOVV3	FOVV2	FOVV1	FOVV0	
H'FFFFFFE69		—	—	—	—	—	—	—	—	
H'FFFFFFE6A to H'FFFFFFE70	—	—	—	—	—	—	—	—	—	—
H'FFFFFFE71	DRCR0	—	—	—	—	—	—	RS1	RS0	DMAC (channel 0)
H'FFFFFFE72	DRCR1	—	—	—	—	—	—	RS1	RS0	DMAC (channel 1)
H'FFFFFFE73 to H'FFFFFFE7F	—	—	—	—	—	—	—	—	—	—
H'FFFFFFE80	WTCSR*	OVF	WT/IT	TME	—	—	CKS2	CKS1	CKS0	WDT
H'FFFFFFE81	WTCNT*									
H'FFFFFFE82	—	—	—	—	—	—	—	—	—	
H'FFFFFFE83	RSTCSR*	WOVF	RSTE	RSTS	—	—	—	—	—	
H'FFFFFFE84 to H'FFFFFFE90	—	—	—	—	—	—	—	—	—	
H'FFFFFFE91	SBYCR	SBY	HIZ	—	MSTP4	MSTP3	MSTP2	MSTP1	MSTP0	Power-down
H'FFFFFFE92	CCR	W1	W0	—	CP	TW	OC	ID	CE	Cache
H'FFFFFFE93 to H'FFFFFFE9F	—	—	—	—	—	—	—	—	—	—

Note: Address for reading. When writing, the address is H'FFFFFFE80 for WTCSR and WTCNT, and H'FFFFFFE82 for RSTCSR. See Section 12.2.4, Register Access, in Section 12, Watchdog Timer (WDT), for more information.

Address	Abbrevia- tion of Register	Bit Name								Module
		Bit 7	Bit 6	Bit 5	Bit 4	Bit 3	Bit 2	Bit 1	Bit 0	
H'FFFFFFE0	ICR	NIMIL	—	—	—	—	—	—	NIMIE	INTC
H'FFFFFFE1		—	—	—	—	—	—	—	VECMD	
H'FFFFFFE2	IPRA	DIVUIP3	DIVUIP2	DIVUIP1	DIVUIP0	DMACI3	DMACI2	DMACI1	DMACI0	
H'FFFFFFE3		WDTIP3	WDTIP2	WDTIP1	WDTIP0	—	—	—	—	
H'FFFFFFE4	VCRWDT	—	WITV6	WITV5	WITV4	WITV3	WITV2	WITV1	WITV0	
H'FFFFFFE5		—	BCM V6	BCM V5	BCM V4	BCM V3	BCM V2	BCM V1	BCM V0	
H'FFFFFFE6	—	—	—	—	—	—	—	—	—	—
to H'FFFFFFEF										
H'FFFFFFF0	DVSR									DIVU
H'FFFFFFF1										
H'FFFFFFF2										
H'FFFFFFF3										
H'FFFFFFF4	DVDNT									
H'FFFFFFF5										
H'FFFFFFF6										
H'FFFFFFF7										
H'FFFFFFF8	DVCR	—	—	—	—	—	—	—	—	
H'FFFFFFF9		—	—	—	—	—	—	—	—	
H'FFFFFFFA		—	—	—	—	—	—	—	—	
H'FFFFFFFB		—	—	—	—	—	—	OVFIE	OVF	
H'FFFFFFFC	VCRDIV	—	—	—	—	—	—	—	—	
H'FFFFFFFD		—	—	—	—	—	—	—	—	
H'FFFFFFFE										
H'FFFFFFF0F										
H'FFFFFFF10	DVDNTH									
H'FFFFFFF11										
H'FFFFFFF12										
H'FFFFFFF13										

Address	Abbreviation of Register	Bit Name								Module
		Bit 7	Bit 6	Bit 5	Bit 4	Bit 3	Bit 2	Bit 1	Bit 0	
H'FFFFFF14	DVDNTL									DIVU
H'FFFFFF15										
H'FFFFFF16										
H'FFFFFF17										
H'FFFFFF18 to H'FFFFFF3F	—	—	—	—	—	—	—	—	—	—
H'FFFFFF40	BARAH	BAA31	BAA30	BAA29	BAA28	BAA27	BAA26	BAA25	BAA24	UBC
H'FFFFFF41		BAA23	BAA22	BAA21	BAA20	BAA19	BAA18	BAA17	BAA16	(channel A)
H'FFFFFF42	BARAL	BAA15	BAA14	BAA13	BAA12	BAA11	BAA10	BAA9	BAA8	
H'FFFFFF43		BAA7	BAA6	BAA5	BAA4	BAA3	BAA2	BAA1	BAA0	
H'FFFFFF44	BAMRAH	BAMA31	BAMA30	BAMA29	BAMA28	BAMA27	BAMA26	BAMA25	BAMA24	
H'FFFFFF45		BAMA23	BAMA22	BAMA21	BAMA20	BAMA19	BAMA18	BAMA17	BAMA16	
H'FFFFFF46	BAMRAL	BAMA15	BAMA14	BAMA13	BAMA12	BAMA11	BAMA10	BAMA9	BAMA8	
H'FFFFFF47		BAMA7	BAMA6	BAMA5	BAMA4	BAMA3	BAMA2	BAMA1	BAMA0	
H'FFFFFF48	BBRA	—	—	—	—	—	—	—	—	
H'FFFFFF49		CPA1	CPA0	IDA1	IDA0	RWA1	RWA0	SZA1	SZA0	
H'FFFFFF4A to H'FFFFFF5F	—	—	—	—	—	—	—	—	—	—
H'FFFFFF60	BARBH	BAB31	BAB30	BAB29	BAB28	BAB27	BAB26	BAB25	BAB24	UBC
H'FFFFFF61		BAB23	BAB22	BAB21	BAB20	BAB19	BAB18	BAB17	BAB16	(channel B)
H'FFFFFF62	BARBL	BAB15	BAB14	BAB13	BAB12	BAB11	BAB10	BAB9	BAB8	
H'FFFFFF63		BAB7	BAB6	BAB5	BAB4	BAB3	BAB2	BAB1	BAB0	
H'FFFFFF64	BAMRBH	BAMB31	BAMB30	BAMB29	BAMB28	BAMB27	BAMB26	BAMB25	BAMB24	
H'FFFFFF65		BAMB23	BAMB22	BAMB21	BAMB20	BAMB19	BAMB18	BAMB17	BAMB16	

Address	Abbreviation of Register	Bit Name								Module
		Bit 7	Bit 6	Bit 5	Bit 4	Bit 3	Bit 2	Bit 1	Bit 0	
H'FFFFFF66	BAMRBL	BAMB15	BAMB14	BAMB13	BAMB12	BAMB11	BAMB10	BAMB9	BAMB8	UBC (channel B)
H'FFFFFF67		BAMB7	BAMB6	BAMB5	BAMB4	BAMB3	BAMB2	BAMB1	BAMB0	
H'FFFFFF68	BBRB	—	—	—	—	—	—	—	—	
H'FFFFFF69		CPB1	CPB0	IDB1	IDB0	RWB1	RWB0	SZB1	SZB0	
H'FFFFFF6A to H'FFFFFF6F	—	—	—	—	—	—	—	—	—	
H'FFFFFF70	BDRBH	BDB31	BDB30	BDB29	BDB28	BDB27	BDB26	BDB25	BDB24	
H'FFFFFF71		BDB23	BDB22	BDB21	BDB20	BDB19	BDB18	BDB17	BDB16	
H'FFFFFF72	BDRBL	BDB15	BDB14	BDB13	BDB12	BDB11	BDB10	BDB9	BDB8	
H'FFFFFF73		BDB7	BDB6	BDB5	BDB4	BDB3	BDB2	BDB1	BDB0	
H'FFFFFF74	BDMRBH	BDMB31	BDMB30	BDMB29	BDMB28	BDMB27	BDMB26	BDMB25	BDMB24	
H'FFFFFF75		BDMB23	BDMB22	BDMB21	BDMB20	BDMB19	BDMB18	BDMB17	BDMB16	
H'FFFFFF76	BDMRBL	BDMB15	BDMB14	BDMB13	BDMB12	BDMB11	BDMB10	BDMB9	BDMB8	
H'FFFFFF77		BDMB7	BDMB6	BDMB5	BDMB4	BDMB3	BDMB2	BDMB1	BDMB0	
H'FFFFFF78	BRCR	CMFCA	CMFPA	EBBE	UMD	—	PCBA	—	—	
H'FFFFFF79		CMFCB	CMFPB	—	SEQ	DBEB	PCBB	—	—	
H'FFFFFF7A to H'FFFFFF7F	—	—	—	—	—	—	—	—	—	

Address	Abbreviation of Register	Bit Name								Module
		Bit 7	Bit 6	Bit 5	Bit 4	Bit 3	Bit 2	Bit 1	Bit 0	
H'FFFFFF80	SAR0									DMAC (channel 0)
H'FFFFFF81										
H'FFFFFF82										
H'FFFFFF83										
H'FFFFFF84	DAR0									
H'FFFFFF85										
H'FFFFFF86										
H'FFFFFF87										
H'FFFFFF88	TCR0	—	—	—	—	—	—	—	—	
H'FFFFFF89										
H'FFFFFF8A										
H'FFFFFF8B										
H'FFFFFF8C	CHCR0	—	—	—	—	—	—	—	—	
H'FFFFFF8D		—	—	—	—	—	—	—		
H'FFFFFF8E		DM1	DM0	SM1	SM0	TS1	TS0	AR	AM	
H'FFFFFF8F		AL	DS	DL	TB	TA	IE	TE	DE	
H'FFFFFF90	SAR1									DMAC (channel 1)
H'FFFFFF91										
H'FFFFFF92										
H'FFFFFF93										
H'FFFFFF94	DAR1									
H'FFFFFF95										
H'FFFFFF96										
H'FFFFFF97										
H'FFFFFF98	TCR1	—	—	—	—	—	—	—	—	
H'FFFFFF99										
H'FFFFFF9A										
H'FFFFFF9B										

Address	Abbreviation of Register	Bit Name								Module
		Bit 7	Bit 6	Bit 5	Bit 4	Bit 3	Bit 2	Bit 1	Bit 0	
H'FFFFFF9C	CHCR1	—	—	—	—	—	—	—	—	DMAC (channel 1)
H'FFFFFF9D		—	—	—	—	—	—	—	—	
H'FFFFFF9E		DM1	MD0	SM1	SM0	TS1	TS0	AR	AM	
H'FFFFFF9F		AL	DS	DL	TB	TA	IE	TE	DE	
H'FFFFFFA0	VCRMA0	—	—	—	—	—	—	—	—	DMAC (channel 0)
H'FFFFFFA1		—	—	—	—	—	—	—	—	
H'FFFFFFA2		—	—	—	—	—	—	—	—	
H'FFFFFFA3		VC7	VC6	VC5	VC4	VC3	VC2	VC1	VC0	
H'FFFFFFA4 to H'FFFFFFA7	—	—	—	—	—	—	—	—	—	
H'FFFFFFA8	VCRDMA1	—	—	—	—	—	—	—	—	DMAC (channel 1)
H'FFFFFFA9		—	—	—	—	—	—	—	—	
H'FFFFFFAA		—	—	—	—	—	—	—	—	
H'FFFFFFAB		VC7	VC6	VC5	VC4	VC3	VC2	VC1	VC0	
H'FFFFFFAC to H'FFFFFFAF	—	—	—	—	—	—	—	—	—	
H'FFFFFFB0	DMAOR	—	—	—	—	—	—	—	—	DMAC (channels 0 and 1)
H'FFFFFFB1		—	—	—	—	—	—	—	—	
H'FFFFFFB2		—	—	—	—	—	—	—	—	
H'FFFFFFB3		—	—	—	—	PR	AE	NMIF	DME	
H'FFFFFFB4 to H'FFFFFFDF	—	—	—	—	—	—	—	—	—	

Address	Abbreviation of Register	Bit Name								Module
		Bit 7	Bit 6	Bit 5	Bit 4	Bit 3	Bit 2	Bit 1	Bit 0	
H'FFFFFFE0		—	—	—	—	—	—	—	—	BSC
H'FFFFFFE1		—	—	—	—	—	—	—	—	
H'FFFFFFE2	BCR1	MASTR	—	—	ENDIAN	BSTROM	PSHR	AHLW1	AHLW0	
H'FFFFFFE3		A1LW1	A1LW0	A0LW1	A0LW0	—	DRAM2	DRAM1	DRAM0	
H'FFFFFFE4	BCR2	—	—	—	—	—	—	—	—	
H'FFFFFFE5		—	—	—	—	—	—	—	—	
H'FFFFFFE6		—	—	—	—	—	—	—	—	
H'FFFFFFE7		A3SZ1	A3SZ0	A2SZ1	A2SZ0	A1SZ1	A1SZ0	—	—	
H'FFFFFFE8	WCR	—	—	—	—	—	—	—	—	
H'FFFFFFE9		—	—	—	—	—	—	—	—	
H'FFFFFFEA		IW31	IW30	IW20	IW21	IW10	IW11	IW01	IW00	
H'FFFFFFEB		W31	W30	W20	W21	W10	W11	W01	W00	
H'FFFFFFEC	MCR	—	—	—	—	—	—	—	—	
H'FFFFFFED		—	—	—	—	—	—	—	—	
H'FFFFFFEE		TRP	RCD	TRWL	TRAS1	TRS0	BE	RASD	—	
H'FFFFFFEF		AMX2	SZ	AMX1	AMX0	RFSH	RMD	—	—	
H'FFFFFFF0	RTCSR	—	—	—	—	—	—	—	—	
H'FFFFFFF1		—	—	—	—	—	—	—	—	
H'FFFFFFF2		—	—	—	—	—	—	—	—	
H'FFFFFFF3		CMF	CMIE	CKS2	CKS1	CKS0	—	—	—	
H'FFFFFFF4	RTCNT	—	—	—	—	—	—	—	—	
H'FFFFFFF5		—	—	—	—	—	—	—	—	
H'FFFFFFF6		—	—	—	—	—	—	—	—	
H'FFFFFFF7		—	—	—	—	—	—	—	—	
H'FFFFFFF8	RTCOR	—	—	—	—	—	—	—	—	
H'FFFFFFF9		—	—	—	—	—	—	—	—	
H'FFFFFFFA		—	—	—	—	—	—	—	—	
H'FFFFFFFB		—	—	—	—	—	—	—	—	
H'FFFFFFFC	—	—	—	—	—	—	—	—	—	—
H'FFFFFFFD	to									
H'FFFFFFFE	H'FFFFFFF									

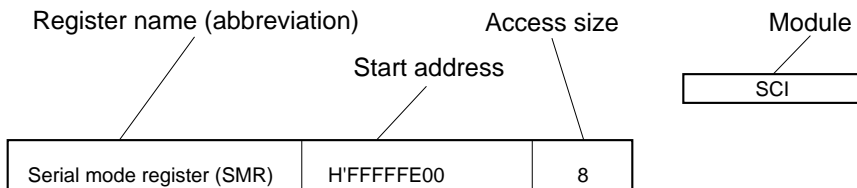

Register overview

Item	Bit							
	7	6	5	4	3	2	1	0
Bit Name	C/A	CHR	PE	O/E	STOP	MP	CKS1	CKS0
Initial Value	0	0	0	0	0	0	0	0
R/W	R/W	R/W	R/W	R/W	R/W	R/W	R/W	R/W

Bit function

Bit	Bit Name	Value	Description
7	Communication mode (C/A)	0	Asynchronous mode (Initial value)
		1	Clocked synchronous mode
6	Character length (CHR)	0	Eight-bit data (Initial value)
		1	Seven-bit data
5	Parity enable (PE)	0	Parity bit not added or checked (Initial value)
		1	Parity bit added and checked
4	Parity mode (OE)	0	Even parity (Initial value)
		1	Odd parity
3	Stop bit length (STOP)	0	One stop bit (Initial value)
		1	Two stop bits
2	Multiprocessor mode (MP)	0	Multiprocessor function disabled (Initial value)
1	Clock select 1 and 0 (CKS1, CKS0)	0 0	$\phi/4$ (Initial value)
		0 1	$\phi/16$
		1 0	$\phi/64$
0		1 1	$\phi/256$

Bit number

Bit name (abbreviation)

Bit value
 (When there is a set of bits, the upper bit is on the left, and the lower bit on the right.)

Bit description

et4U.com

DataShee

Serial mode register (SMR)	H'FFFFFFE00	8
----------------------------	-------------	---

Bit

Item	7	6	5	4	3	2	1	0
Bit Name	C/A	CHR	PE	O/E	STOP	MP	CKS1	CKS0
Initial Value	0	0	0	0	0	0	0	0
R/W	R/W	R/W	R/W	R/W	R/W	R/W	R/W	R/W

Bit	Bit Name	Value	Description
7	Communication mode (C/A)	0	Asynchronous mode (Initial value)
		1	Clocked synchronous mode
6	Character length (CHR)	0	Eight-bit data (Initial value)
		1	Seven-bit data
5	Parity enable (PE)	0	Parity bit not added or checked (Initial value)
		1	Parity bit added and checked
4	Parity mode (OE)	0	Even parity (Initial value)
		1	Odd parity
3	Stop bit length (STOP)	0	One stop bit (Initial value)
		1	Two stop bits
2	Multiprocessor mode (MP)	0	Multiprocessor function disabled (Initial value)
		1	Multiprocessor format selected
1	Clock select 1 and 0 (CKS1, CKS0)	0 0	$\phi/4$ (Initial value)
		0 1	$\phi/16$
		1 0	$\phi/64$
0		1 0	$\phi/64$
		1 1	$\phi/256$

Bit rate register (BRR)	H'FFFFFFE01	8
-------------------------	-------------	---

Bit

Item	7	6	5	4	3	2	1	0
Bit Name								
Initial Value	1	1	1	1	1	1	1	1
R/W	R/W	R/W	R/W	R/W	R/W	R/W	R/W	R/W

Bit	Bit Name	Description
7 to 0	(Bit rate setting)	Sets serial transmit/receive bit rate

Serial control register (SCR)	H'FFFFFFE02	8
-------------------------------	-------------	---

Item	Bit							
	7	6	5	4	3	2	1	0
Bit Name	TIE	RIE	TE	RE	MPIE	TEIE	CKE1	CKE0
Initial Value	0	0	0	0	0	0	0	0
R/W	R/W	R/W	R/W	R/W	R/W	R/W	R/W	R/W

Bit	Bit Name	Value	Description
7	Transmit interrupt enable (TIE)	0	Transmit-data-empty interrupt request (TXI) is disabled (Initial value)
		1	Transmit-data-empty interrupt request (TXI) is enabled
6	Receive interrupt enable (RIE)	0	Receive-data-full interrupt (RXI) and receive-error interrupt (ERI) requests are disabled (Initial value)
		1	Receive-data-full interrupt (RXI) and receive-error interrupt (ERI) requests are enabled
5	Transmit enable (TE)	0	Transmitter disabled (Initial value)
		1	Transmitter enabled
4	Receive enable (RE)	0	Receiver disabled (Initial value)
		1	Receiver enabled
3	Multiprocessor interrupt enable (MPIE)	0	Multiprocessor interrupts are disabled (nomal receive operation) (Initial value). MPE is cleared to 0 when MPIE is cleared to 0, or the multiprocessor bit (MPB) is set to 1 in receive data.
		1	Multiprocessor interrupts are enabled. Receive-data-full interrupt requests (RXI), receive-error interrupt requests (ERI), and setting of the RDRF, FER, and ORER status flags in the serial status register (SSR) are disabled until the multiprocessor bit is set to 1.
2	Transmit-end interrupt enable (TEIE)	0	Transmit-end interrupt (TEI) requests are disabled (Initial value)
		1	Transmit-end interrupt (TEI) requests are enabled
1, 0	Clock enable 1 and 0 (CKE1 and CKE2)	0 0	Asynchronous mode Internal clock, SCK pin used for input pin (input signal is ignored or output pin output level is undefined)
		0 0	Clocked synchronous mode Internal clock, SCK pin used for synchronous clock output
		0 1	Asynchronous mode Internal clock, SCK pin used for clock output
		0 1	Clocked synchronous mode Internal clock, SCK pin used for synchronous clock output
		1 0	Asynchronous mode Internal clock, SCK pin used for clock input
		1 0	Clocked synchronous mode Internal clock, SCK pin used for synchronous clock input
		1 1	Asynchronous mode Internal clock, SCK pin used for clock input
		1 1	Clocked synchronous mode Internal clock, SCK pin used for synchronous clock input

Transmit data register (TDR)	H'FFFFFFE03	8
------------------------------	-------------	---

Item	Bit							
	7	6	5	4	3	2	1	0
Bit Name								
Initial Value	1	1	1	1	1	1	1	1
R/W	R/W	R/W	R/W	R/W	R/W	R/W	R/W	R/W

Bit	Bit Name	Description
7 to 0	(Stores transmit data)	Stores data for serial transmission

Serial status register (SSR)	H'FFFFFFE04	8
------------------------------	-------------	---

Item	Bit							
	7	6	5	4	3	2	1	0
Bit Name	TDRE	RDRF	ORER	FER	PER	TEND	MPB	MPBT
Initial Value	1	0	0	0	0	1	0	0
R/W	R(W)*	R(W)*	R(W)*	R(W)*	R(W)*	R	R	R/W

Note: Only 0 can be written to clear flags.

Bit	Bit Name	Value	Description
7	Transmit data register empty (TDRE)	0	TDR contains valid transmit data TDRE is cleared to 0 when software reads TDRE after it has been set to 1, then writes 0 in TDRE, or the DMAC writes data in TDR.
		1	TDR does not contain valid transmit data (Initial value) TDRE is set to 1 when the chip is reset or enters standby mode, the TE bit in the serial control register (SCR) is cleared to 0, or TDR contents are loaded into TSR, so new data can be written in TDR.
6	Receive data register full (RDRF)	0	RDR does not contain valid received data (Initial value) RDRF is cleared to 0 when the chip is reset or enters standby mode, software reads RDRF after it has been set to 1, then writes 0 in RDRF, or the DMAC reads data from RDR.
		1	RDR contains valid received data RDRF is set to 1 when serial data is received normally and transferred from RSR to RDR.

Bit	Bit Name	Value	Description
5	Overrun error (ORER)	0	Receiving is in progress or has ended normally (Initial value) ORER is cleared to 0 when the chip is reset or enters standby mode, or software reads ORER after it has been set to 1, then writes 0 in ORER.
		1	A receive overrun error occurred ORER is set to 1 if reception of the next serial data ends when RDRF is set to 1.
4	Framing error (FER)	0	Receiving is in progress or has ended normally (Initial value) FER is cleared to 0 when the chip is reset or enters standby mode, or software reads FER after it has been set to 1, then writes 0 in FER.
		1	A receive framing error occurred FER is set to 1 if the stop bit at the end of receive data is checked and found to be 0.
3	Parity error (PER)	0	Receiving is in progress or has ended normally (Initial value) PER is cleared to 0 when the chip is reset or enters standby mode or software reads PER after it has been set to 1, then writes 0 in PER.
		1	A receive parity error occurred PER is set to 1 if the number of 1s in receive data, including the parity bit, does not match the even or odd parity setting of the parity mode bit (O/ \bar{E}) in the serial mode register (SMR).
2	Transmit end (TEND)	0	Transmission is in progress TEND is cleared to 0 when software reads TDRD after it has been set to 1, then writes 0 in TDRE, or the DMAC writes data in TDR.
		1	End of transmission (Initial value) TEND is set to 1 when the chip is reset or enters standby mode, TE is cleared to 0 in the serial control register (SCR), or TDRE is 1 when the last bit of a one-byte serial character is transmitted.
1	Multiprocessor bit (MPB)	0	Multiprocessor bit value in receive data is 0 (Initial value)
0	Multiprocessor bit transfer (MPBT)	1	Multiprocessor bit value in receive data is 1
		0	Multiprocessor bit value in transmit data is 0 (Initial value)
		1	Multiprocessor bit value in transmit data is 1

Receive data register (RDR)	H'FFFFFFE05	8
-----------------------------	-------------	---

Item	Bit							
	7	6	5	4	3	2	1	0
Bit Name								
Initial Value	0	0	0	0	0	0	0	0
R/W	R	R	R	R	R	R	R	R

Bit	Bit Name	Description
7 to 0	(Stores serial receive data)	Stores the received serial data

DataSheet4U.com

et4U.com

DataShee

DataSheet4U.com

www.DataSheet4U.com

Timer interrupt enable register (TIER)	H'FFFFFFE10	8
--	-------------	---

Bit

Item	7	6	5	4	3	2	1	0
Name	ICIE	—	—	—	OCIAE	OCIBE	OVIE	—
Initial Value	0	0	0	0	0	0	0	1
R/W	R/W	R/W	R/W	R/W	R/W	R/W	R/W	R/W

Bit	Bit Name	Value	Description
7	Input capture interrupt enable (ICIE)	0	Disables interrupt requests (ICI) from ICF (Initial value)
		1	Enables interrupt requests (ICI) from the ICF
3	Output compare interrupt A enable (OCIAE)	0	Disables interrupt requests (OCIA) from OCFA (Initial value)
		1	Enables interrupt requests (OCIA) from OCFA
2	Output compare interrupt B enable (OCIBE)	0	Disables interrupt requests (OCIB) from OCFB (Initial value)
		1	Enables interrupt requests (OCIB) from OCFB
1	Timer overflow interrupt enable (OVIE)	0	Disables interrupt requests (OVI) from OVF (Initial value)
		1	Enables interrupt requests (OVI) from OVF

Free-running timer control/status register (FTCSR)	H'FFFFFFE11	8
--	-------------	---

Bit

Item	7	6	5	4	3	2	1	0
Bit Name	ICF	—	—	—	OCFA	OCFB	OVF	CCLRA
Initial Value	0	0	0	0	0	0	0	0
R/W	R/(W)*	—	—	—	R/(W)*	R/(W)*	R/(W)*	R/W

Note: For bits 7, and 3 to 1, the only value that can be written is 0 (to clear the flags)

Bit	Bit Name	Value	Description
7	Input capture flag (ICF)	0	Clear conditions: When ICF = 1, ICF is read and then 0 is written to it (Initial value)
		1	Set conditions: When FRC value is sent to ICR by the input capture signal
3	Output compare flag A (OCFA)	0	Clear conditions: When OCFA = 1, OCFA is read and then 0 is written to it (Initial value)
		1	Set conditions: When FRC value becomes equal to OCRA

Bit	Bit Name	Value	Description
2	Output compare flag B (OCFB)	0	Clear conditions: When OCFB = 1, OCFB is read and then 0 is written to it (Initial value)
		1	Set conditions: When FRC value becomes equal to OCRB
1	Timer overflow flag (OVF)	0	Clear conditions: When OVF = 1, OVF is read and then 0 is written to it (Initial value)
		1	Set conditions: When FRC value changes from H'FFFF to H'0000
0	Counter clear A (CCLRA)	0	Disables FRC clear (Initial value)
		1	Clears FRC on compare match A

Free-running counter (FRC)	H'FFFFFFE12(FRCH) H'FFFFFFE13(FRCL)	16*
----------------------------	--	-----

Note: Access FRCH first and then FRCL, two 8-bit units.

Item	Bit															
	15	14	13	12	11	10	9	8	7	6	5	4	3	2	1	0
Bit Name																
Initial Value	0	0	0	0	0	0	0	0	0	0	0	0	0	0	0	0
R/W	R/W	R/W	R/W	R/W	R/W	R/W	R/W	R/W	R/W	R/W	R/W	R/W	R/W	R/W	R/W	R/W

DataSheet4U.com

Bit	Bit Name	Description
15 to 0	(Count value)	Counts input clock pulses

Output compare register A/B* ¹ (OCRA/B)	H'FFFFFFE14(OCRA/BH) H'FFFFFFE15(OCRA/BL)	16* ²
--	--	------------------

Notes: 1. Switch registers with OCRA in TOCR.

2. Access OCRA/BH first and then OCRA/BL, in two 8-bit units.

Item	Bit															
	15	14	13	12	11	10	9	8	7	6	5	4	3	2	1	0
Bit Name																
Initial Value	0	0	0	0	0	0	0	0	0	0	0	0	0	0	0	0
R/W	R/W	R/W	R/W	R/W	R/W	R/W	R/W	R/W	R/W	R/W	R/W	R/W	R/W	R/W	R/W	R/W

Bit	Bit Name	Description
15 to 0	(FRC value comparison)	Sets OCFA when OCFA = FRC Sets OCFB when OCFB = FFC

Timer control register (TCR)	H'FFFFFFE16	8
------------------------------	-------------	---

Item	Bit							
	7	6	5	4	3	2	1	0
Bit Name	IEDGA	—	—	—	—	—	CKS1	CKS0
Initial Value	0	0	0	0	0	0	0	0
R/W	R/W	R/W	R/W	R/W	R/W	R/W	R/W	R/W

Bit	Bit Name	Value	Description
7	Input edge select (IEDG)	0	Captures input on falling edge (Initial value)
		1	Captures input on rising edge
1, 0	Clock selects (CKS1 and CKS0)	0 0	Internal clock: count on $\phi/8$ (Initial value)
		0 1	Internal clock: count on $\phi/32$
		1 0	Internal clock: count on $\phi/128$
		1 1	External clock: count on rising edge

Timer output compare control register (TOCR)	H'FFFFFFE17	8
--	-------------	---

Item	Bit							
	7	6	5	4	3	2	1	0
Bit Name	—	—	—	OCRS	—	—	OLVLA	OLVLB
Initial Value	1	1	1	0	0	0	0	0
R/W	—	—	—	R/W	R/W	R/W	R/W	R/W

Bit	Bit Name	Value	Description
4	Output compare register select (OCRS)	0	Selects OCRA register (Initial value)
		1	Selects OCRB register
1	Output level A (OLVLA)	0	Outputs 0 on compare match A (Initial value)
		1	Outputs 1 on compare match A
0	Output level B (OLVLB)	0	Outputs 0 on compare match B (Initial value)
		1	Outputs 1 on compare match B

Input capture register (ICR)	H'FFFFFFE18 (ICRH) H'FFFFFFE19 (ICRL)	16*
------------------------------	--	-----

Note: Access ICRH first and then ICRL, in two 8-bit units.

Item	Bit															
	15	14	13	12	11	10	9	8	7	6	5	4	3	2	1	0
Bit Name																
Initial Value	0	0	0	0	0	0	0	0	0	0	0	0	0	0	0	0
R/W	R	R	R	R	R	R	R	R	R	R	R	R	R	R	R	R

Bit	Bit Name	Description
15 to 0	(Stores FRC value)	Stores FRC value when an input capture signal occurs

DataSheet4U.com

et4U.com

DataShee

DataSheet4U.com

www.DataSheet4U.com

Interrupt priority level setting register A (IPRA)	H'FFFFFFE2	8/16
--	------------	------

Item	Bit															
	15	14	13	12	11	10	9	8	7	6	5	4	3	2	1	0
Bit Name	DIVU IP3	DIVU IP2	DIVU IP1	DIVU IP0	DMAC IP3	DMAC IP2	DMAC IP1	DMAC IP0	WDT P3	WDT IP2	WDT IP1	WDT IP0	—	—	—	—
Initial Value	0	0	0	0	0	0	0	0	0	0	0	0	0	0	0	0
R/W	R/W	R/W	R/W	R/W	R/W	R/W	R/W	R/W	R/W	R/W	R/W	R/W	R	R	R	R

Bit	Bit Name	Description
15 to 12	Division unit (DIVU) interrupt priority level (DIVUIP3–DIVUIP0)	These bits set the division unit (DIVU) interrupt priority level
11 to 8	DMA controller interrupt priority level (DMACIP3–DMACIP0)	These bits set the DMA controller (DMAC) interrupt priority level
7 to 4	Watchdog timer (WDT) interrupt priority level (WDTIP3–WDTIP0)	These bits set the watchdog timer (WDT) interrupt priority level and bus state controller (BSC) interrupt priority level

Interrupt priority level setting register B (IPRB)	H'FFFFFFE0	8/16
--	------------	------

Item	Bit															
	15	14	13	12	11	10	9	8	7	6	5	4	3	2	1	0
Bit Name	SCI IP3	SCI IP2	SCI IP1	SCI IP0	FRT IP3	FRT IP2	FRT IP1	FRT IP0	—	—	—	—	—	—	—	—
Initial Value	0	0	0	0	0	0	0	0	0	0	0	0	0	0	0	0
R/W	R/W	R/W	R/W	R/W	R/W	R/W	R/W	R/W	R	R	R	R	R	R	R	R

Bit	Bit Name	Description
15 to 12	Serial communication interface (SCI) interrupt priority level (SCIIP3–SCIIP0)	These bits set the serial communication interface (SCI) interrupt priority level
11 to 8	Free-running timer (FRT) interrupt priority level (FRTIP3–FRTIP0)	These bits set the free-running timer (FRT) interrupt priority level

Vector number setting register A (VCRA)	H'FFFFFFE62	8/16
---	-------------	------

Bit

Item	15	14	13	12	11	10	9	8	7	6	5	4	3	2	1	0
Bit Name		SER	SER	SER	SER	SER	SER	SER		SRX	SRX	SRX	SRX	SRX	SRX	SRX
	—	V6	V5	V4	V3	V2	V1	V0	—	V6	V5	V4	V3	V2	V1	V0
Initial Value	0	0	0	0	0	0	0	0	0	0	0	0	0	0	0	0
R/W	R	R/W	R/W	R/W	R/W	R/W	R/W	R/W	R	R/W	R/W	R/W	R/W	R/W	R/W	R/W

Bit	Bit Name	Description
14 to 8	Serial communication interface (SCI) receive-error interrupt vector number (SERV6–SERV0)	These bits set the vector number for the serial communication interface (SCI) receive-error interrupt (ERI)
6 to 0	Serial communication interface (SCI) receive-data-full interrupt vector number (SRXV6–SRXV0)	These bits set the vector number for the serial communication interface (SCI) receive-data-full interrupt (RXI)

Vector number setting register B (VCRB)	H'FFFFFFE64	8/16
---	-------------	------

Bit

Item	15	14	13	12	11	10	9	8	7	6	5	4	3	2	1	0
Bit Name		STX	STX	STX	STX	STX	STX	STX		STE	STE	STE	STE	STE	STE	STE
	—	V6	V5	V4	V3	V2	V1	V0	—	V6	V5	V4	V3	V2	V1	V0
Initial Value	0	0	0	0	0	0	0	0	0	0	0	0	0	0	0	0
R/W	R	R/W	R/W	R/W	R/W	R/W	R/W	R/W	R	R/W	R/W	R/W	R/W	R/W	R/W	R/W

Bit	Bit Name	Description
14 to 8	Serial communication interface (SCI) transmit-data-empty interrupt vector number (STXV6–STXV0)	These bits set the vector number for the serial communication interface (SCI) transmit-data-empty interrupt (TXI)
6 to 0	Serial communication interface (SCI) transmit-end interrupt vector number (STEV6–STEV0)	These bits set the vector number for the serial communication interface (SCI) transmit-end interrupt (TEI)

Vector number setting register C (VCRC)	H'FFFFFFE66	8/16
---	-------------	------

Item	Bit															
	15	14	13	12	11	10	9	8	7	6	5	4	3	2	1	0
Bit Name	—	FIC V6	FIC V5	FIC V4	FIC V3	FIC V2	FIC V1	FIC V0	—	FOC V6	FOC V5	FOC V4	FOC V3	FOC V2	FOC V1	FOC V0
Initial Value	0	0	0	0	0	0	0	0	0	0	0	0	0	0	0	0
R/W	R	R/W	R/W	R/W	R/W	R/W	R/W	R/W	R	R/W	R/W	R/W	R/W	R/W	R/W	R/W

Bit	Bit Name	Description
14 to 8	Free-running timer (FRT) input-capture interrupt vector number (FICV6–FICV0)	These bits set the vector number for the free-running timer (FRT) input-capture interrupt (ICI)
6 to 0	Free-running timer (FRT) output-compare interrupt vector number (FOCV6–FOCV0)	These bits set the vector number for the free-running timer (FRT) output-compare interrupt (OCI)

Vector number setting register D (VCRD)	H'FFFFFFE68	8/16
---	-------------	------

Item	Bit															
	15	14	13	12	11	10	9	8	7	6	5	4	3	2	1	0
Bit Name	—	FOV V6	FOV V5	FOV V4	FOV V3	FOV V2	FOV V1	FOV V0	—	—	—	—	—	—	—	—
Initial Value	0	0	0	0	0	0	0	0	0	0	0	0	0	0	0	0
R/W	R	R/W	R/W	R/W	R/W	R/W	R/W	R/W	R	R	R	R	R	R	R	R

Bit	Bit Name	Description
14 to 8	Free-running timer (FRT) overflow interrupt vector number (FOVV6–FOVV0)	These bit set the vector number for the free-running timer(FRT) overflow interrupt (OVI)

Vector number setting register WDT (VCRWDT)	H'FFFFFFE4	8/16
--	------------	------

Item	Bit															
	15	14	13	12	11	10	9	8	7	6	5	4	3	2	1	0
Bit Name	—	WIT V6	WIT V5	WIT V4	WIT V3	WIT V2	WIT V1	WIT V0	—	BCM V6	BCM V5	BCM V4	BCM V3	BCM V2	BCM V1	BCM V0
Initial Value	0	0	0	0	0	0	0	0	0	0	0	0	0	0	0	0
R/W	R	R/W	R/W	R/W	R/W	R/W	R/W	R/W	R	R/W	R/W	R/W	R/W	R/W	R/W	R/W

Bit	Bit Name	Description
14 to 8	Watchdog timer (WDT) interval interrupt vector number (WITV6–WITV0)	These bits set the vector number for the interval interrupt (ITI) of the watchdog timer (WDT)
6 to 0	Bus state controller (BSC) compare match interrupt vector number (BCM V6–BCM V0)	These bits set the vector number for the compare match interrupt (CMI) of the bus state controller (BSC)

Vector number setting register DIV (VCRDIV)	H'FFFFFF0C	32
--	------------	----

DataSheet4U.com

Item	Bit															
	31	30	29	28	27	26	25	24	23	22	21	20	19	18	17	16
Bit Name	—	—	—	—	—	—	—	—	—	—	—	—	—	—	—	—
Initial Value	0	0	0	0	0	0	0	0	0	0	0	0	0	0	0	0
R/W	R	R	R	R	R	R	R	R	R	R	R	R	R	R	R	R
Item	15	14	13	12	11	10	9	8	7	6	5	4	3	2	1	0
Bit Name	—	—	—	—	—	—	—	—	—	—	—	—	—	—	—	—
Initial Value	—	—	—	—	—	—	—	—	—	—	—	—	—	—	—	—
R/W	R/W	R/W	R/W	R/W	R/W	R/W	R/W	R/W	R/W	R/W	R/W	R/W	R/W	R/W	R/W	R/W

Bit	Bit Name	Description
15 to 0	(Vector number setting)	These bits set the vector number for the interrupt when caused by overflow or underflow of the division unit

Vector number setting registers DMA0 and DMA1 (VCRDMA0, VCRDMA1)	H'FFFFFFA0 (channel 0) H'FFFFFFA8 (channel 1)	32
--	--	----

Item	Bit															
	31	30	29	28	27	26	25	24	23	22	21	20	19	18	17	16
Bit Name	—	—	—	—	—	—	—	—	—	—	—	—	—	—	—	—
Initial Value	0	0	0	0	0	0	0	0	0	0	0	0	0	0	0	0
R/W	R	R	R	R	R	R	R	R	R	R	R	R	R	R	R	R
Item	15	14	13	12	11	10	9	8	7	6	5	4	3	2	1	0
Bit Name	—	—	—	—	—	—	—	—	VC7	VC6	VC5	VC4	VC3	VC2	VC1	VC0
Initial Value	0	0	0	0	0	0	0	0	—	—	—	—	—	—	—	—
R/W	R	R	R	R	R	R	R	R	R/W	R/W	R/W	R/W	R/W	R/W	R/W	R/W

Bit	Bit Name	Description
7 to 0	Vector number bits (VC7–VC0)	These bits set the vector number at the end of DMA transfer

Interrupt control register (ICR)	H'FFFFFFE0	8/16
----------------------------------	------------	------

Item	Bit															
	15	14	13	12	11	10	9	8	7	6	5	4	3	2	1	0
Bit Name	NMIL	—	—	—	—	—	—	NMIE	—	—	—	—	—	—	—	VEC MD
Initial Value	0/1*	0	0	0	0	0	0	0	—	—	—	—	—	—	—	—
R/W	R	R	R	R	R	R	R	R/W	R	R	R	R	R	R	R	R/W

Note: When NMI input is high: 1; when NMI input is low: 0

Bit	Bit Name	Value	Description
15	NMI input level (NMIL)	0	NMI input level is low
		1	NMI input level is high
8	NMI edge select (NMIE)	0	Interrupt request is detected on falling edge of NMI input (Initial value)
		1	Interrupt request is detected on rising edge of NMI input
1	RL interrupt vector mode select (VECMD)	0	Auto-vector mode, automatically set internally (Initial value)
		1	External vector mode, external input

Watchdog timer control/status register (WTCSR)	H'FFFFFFE80	8 (read) 16 (write)
--	-------------	------------------------

Bit

Item	7	6	5	4	3	2	1	0
Bit Name	OVF	WT/IT	TME	—	—	CKS2	CKS1	CKS0
Initial Value	0	0	0	1	1	0	0	0
R/W	R/(W)*	R/W	R/W	—	—	R/W	R/W	R/W

Note: WTCSR differs from other registers in being more difficult to write. See section 12.2.4, Register Access, for details.

Bit	Bit Name	Value	Description			
7	Overflow flag (OVF)	0	No overflow of WTCNT in interval timer mode (Initial value) Cleared by reading OVF, then writing 0 in OVF			
		1	WTCNT overflow in interval timer mode			
6	Timer mode select (WT/IT)	0	Interval timer mode: Interval timer interrupt (ITI) request to the CPU when WTCNT overflows (Initial value)			
		1	Watchdog timer mode: WDTOVF signal is output externally when WTCNT overflows			
5	Timer enable (TME)	0	Timer disabled: WTCNT is initialized to H'00 and count-up stops (Initial value)			
		1	Timer enabled: WTCNT starts counting A WDTOVF signal or interrupt is generated when WTCNT overflows			
2 to 0	Clock select 2 to 0 (CKS2 to CKS0)	CKS2	CKS1	CKS0	Clock Source	Overflow Interval ($\phi = 28.7$ MHz)
		0	0	0	$\phi/2$ (Initial value)	17.8 μ s
		0	0	1	$\phi/64$	570.8 μ s
		0	1	0	$\phi/128$	1.1ms
		0	1	1	$\phi/256$	2.2ms
		1	0	0	$\phi/512$	4.5ms
		1	0	1	$\phi/1024$	9.1ms
		1	1	0	$\phi/4096$	35.5ms
		1	1	1	$\phi/8192$	73.0ms

Watchdog timer counter (WTCNT)	H'FFFFFFE80 (write)	16 (write)
	H'FFFFFFE81 (read)	8 (read)

Item	Bit							
	7	6	5	4	3	2	1	0
Bit Name								
Initial Value	0	0	0	0	0	0	0	0
R/W	R/W	R/W	R/W	R/W	R/W	R/W	R/W	R/W

Bit	Bit Name	Description
7 to 0	(Count value)	Input clock count value

Reset control/status register (RSTCSR)	H'FFFFFFE82 (write)	16 (write)
	H'FFFFFFE83 (read)	8 (read)

Item	Bit							
	7	6	5	4	3	2	1	0
Bit Name	WOVF	RSTE	RSTS	—	—	—	—	—
Initial Value	0	0	0	1	1	1	1	1
R/W	R/(W)*	R/W	R/W	—	—	—	—	—

Note: Only 0 can be written in bit 7 to clear the flag.

Bit	Bit Name	Value	Description
7	Watchdog timer overflow flag (WOVF)	0	No WTCNT overflow in watchdog timer mode (Initial value) Cleared when software reads WOVF, then writes 0 in WOVF
		1	Set by WTCNT overflow in watchdog timer mode
6	Reset enable (RSTE)	0	No internal reset when WTCNT overflows (Initial value)
		1	Internal reset when WTCNT overflows
5	Reset select (RSTS)	0	Power-on reset (Initial value)
		1	Manual reset

Divisor register (DVSR)	H'FFFFFFE0	32
-------------------------	------------	----

Bit

Item	31	30	29	28	27	26	25	24	23	22	21	20	19	18	17	16
Bit Name																
Initial Value	—	—	—	—	—	—	—	—	—	—	—	—	—	—	—	—
R/W	R/W	R/W	R/W	R/W	R/W	R/W	R/W	R/W	R/W	R/W	R/W	R/W	R/W	R/W	R/W	R/W
Item	15	14	13	12	11	10	9	8	7	6	5	4	3	2	1	0
Bit Name																
Initial Value	—	—	—	—	—	—	—	—	—	—	—	—	—	—	—	—
R/W	R/W	R/W	R/W	R/W	R/W	R/W	R/W	R/W	R/W	R/W	R/W	R/W	R/W	R/W	R/W	R/W

Bit

Bit Name

Description

31 to 0	(Written with divisor)	Used to write the divisor for the operation
---------	------------------------	---

Dividend register L for 32-bit division (DVDNT)	H'FFFFFFE04	32
---	-------------	----

Bit

Item	31	30	29	28	27	26	25	24	23	22	21	20	19	18	17	16
Bit Name																
Initial Value	—	—	—	—	—	—	—	—	—	—	—	—	—	—	—	—
R/W	R/W	R/W	R/W	R/W	R/W	R/W	R/W	R/W	R/W	R/W	R/W	R/W	R/W	R/W	R/W	R/W
Item	15	14	13	12	11	10	9	8	7	6	5	4	3	2	1	0
Bit Name																
Initial Value	—	—	—	—	—	—	—	—	—	—	—	—	—	—	—	—
R/W	R/W	R/W	R/W	R/W	R/W	R/W	R/W	R/W	R/W	R/W	R/W	R/W	R/W	R/W	R/W	R/W

Bit

Bit Name

Description

31 to 0	(Dividend setting)	Set with the 32-bit dividend used for 32-bit/32-bit division operations
---------	--------------------	---

Division control register (DVCR)	H'FFFFFF08	16/32
----------------------------------	------------	-------

		Bit														
Item	31	30	29	28	27	26	25	24	23	22	21	20	19	18	17	16
Bit Name	—	—	—	—	—	—	—	—	—	—	—	—	—	—	—	—
Initial Value	0	0	0	0	0	0	0	0	0	0	0	0	0	0	0	0
R/W	R	R	R	R	R	R	R	R	R	R	R	R	R	R	R	R
Item	15	14	13	12	11	10	9	8	7	6	5	4	3	2	1	0
Bit Name	—	—	—	—	—	—	—	—	—	—	—	—	—	—	IE	OVF
Initial Value	0	0	0	0	0	0	0	0	0	0	0	0	0	0	0	0
R/W	R	R	R	R	R	R	R	R	R	R	R	R	R	R	R/W	R/W

Bit	Bit Name	Value	Description
1	OVF interrupt enable (OVFIE)	0	Disables interrupt request (OVFI) caused by OVF (Initial value)
		1	Enables interrupt request (OVFI) caused by OVF
0	Overflow flag (OVF)	0	No overflow has occurred (Initial value)
		1	Overflow has occurred

Dividend register H (DVDNTH)	H'FFFFFF10	32
------------------------------	------------	----

		Bit															
Item	31	30	29	28	27	26	25	24	23	22	21	20	19	18	17	16	
Bit Name	—	—	—	—	—	—	—	—	—	—	—	—	—	—	—	—	
Initial Value	—	—	—	—	—	—	—	—	—	—	—	—	—	—	—	—	
R/W	R/W	R/W	R/W	R/W	R/W	R/W	R/W	R/W	R/W	R/W	R/W	R/W	R/W	R/W	R/W	R/W	
Item	15	14	13	12	11	10	9	8	7	6	5	4	3	2	1	0	
Bit Name	—	—	—	—	—	—	—	—	—	—	—	—	—	—	—	—	
Initial Value	—	—	—	—	—	—	—	—	—	—	—	—	—	—	—	—	
R/W	R/W	R/W	R/W	R/W	R/W	R/W	R/W	R/W	R/W	R/W	R/W	R/W	R/W	R/W	R/W	R/W	

Bit	Bit Name	Description
31 to 1	(Dividend setting)	Set with the upper 32 bits of the dividend used for 64-bit/32-bit division operations

Dividend register L (DVDNTL)	H'FFFFFF14	32
------------------------------	------------	----

Bit

Item	31	30	29	28	27	26	25	24	23	22	21	20	19	18	17	16
Bit Name																
Initial Value	—	—	—	—	—	—	—	—	—	—	—	—	—	—	—	—
R/W	R/W	R/W	R/W	R/W	R/W	R/W	R/W	R/W	R/W	R/W	R/W	R/W	R/W	R/W	R/W	R/W
Item	15	14	13	12	11	10	9	8	7	6	5	4	3	2	1	0
Bit Name																
Initial Value	—	—	—	—	—	—	—	—	—	—	—	—	—	—	—	—
R/W	R/W	R/W	R/W	R/W	R/W	R/W	R/W	R/W	R/W	R/W	R/W	R/W	R/W	R/W	R/W	R/W

Bit	Bit Name	Description
31 to 1	(Dividend setting)	Set with the lower 32 bits of the dividend used for 64-bit/32-bit division operations

DataSheet4U.com

et4U.com

DataShee

DataSheet4U.com

www.DataSheet4U.com

Break address register AH (BARAH)	H'FFFFFF40	16/32
--------------------------------------	------------	-------

Item	Bit															
	15	14	13	12	11	10	9	8	7	6	5	4	3	2	1	0
Bit Name	BAA 31	BAA 30	BAA 29	BAA 28	BAA 27	BAA 26	BAA 25	BAA 24	BAA 23	BAA 22	BAA 21	BAA 20	BAA 19	BAA 18	BAA 17	BAA 16
Initial Value	0	0	0	0	0	0	0	0	0	0	0	0	0	0	0	0
R/W	R/W	R/W	R/W	R/W	R/W	R/W	R/W	R/W	R/W	R/W	R/W	R/W	R/W	R/W	R/W	R/W

Bit	Bit Name	Description
15 to 0	Break address BAA31– BAA16	These bits specify the upper bits (bit 31 to bit 16) of the channel A break condition address

Break address register AL (BARAL)	H'FFFFFF42	16
--------------------------------------	------------	----

Item	Bit															
	15	14	13	12	11	10	9	8	7	6	5	4	3	2	1	0
Bit Name	BAA 15	BAA 14	BAA 13	BAA 12	BAA 11	BAA 10	BAA 9	BAA 8	BAA 7	BAA 6	BAA 5	BAA 4	BAA 3	BAA 2	BAA 1	BAA 0
Initial Value	0	0	0	0	0	0	0	0	0	0	0	0	0	0	0	0
R/W	R/W	R/W	R/W	R/W	R/W	R/W	R/W	R/W	R/W	R/W	R/W	R/W	R/W	R/W	R/W	R/W

Bit	Bit Name	Description
15 to 0	Break address BAA15– BAA0	These bits specify the lower bits (bit 15 to bit 0) of the channel A break condition address

Break address mask register AH (BAMRAH)	H'FFFFFF44	16/32
---	------------	-------

Item	Bit															
	15	14	13	12	11	10	9	8	7	6	5	4	3	2	1	0
Bit Name	BAM A31	BAM A30	BAM A29	BAM A28	BAM A27	BAM A26	BAM A25	BAM A24	BAM A23	BAM A22	BAM A21	BAM A20	BAM A19	BAM A18	BAM A17	BAM A16
Initial Value	0	0	0	0	0	0	0	0	0	0	0	0	0	0	0	0
R/W	R/W	R/W	R/W	R/W	R/W	R/W	R/W	R/W	R/W	R/W	R/W	R/W	R/W	R/W	R/W	R/W

Bit	Bit Name	Value	Description
15 to 0	Break address BAMA31–BAMA16	0	Channel A break address BAA _n is included in the break conditions (Initial value)
		1	Channel A break address BAA _n is not included in the break conditions

n = 31 to 16

Break address mask register AL (BAMRAL)	H'FFFFFF46	16
---	------------	----

Item	Bit															
	15	14	13	12	11	10	9	8	7	6	5	4	3	2	1	0
Bit Name	BAM A15	BAM A14	BAM A13	BAM A12	BAM A11	BAM A10	BAM A9	BAM A8	BAM A7	BAM A6	BAM A5	BAM A4	BAM A3	BAM A2	BAM A1	BAM A0
Initial Value	0	0	0	0	0	0	0	0	0	0	0	0	0	0	0	0
R/W	R/W	R/W	R/W	R/W	R/W	R/W	R/W	R/W	R/W	R/W	R/W	R/W	R/W	R/W	R/W	R/W

Bit	Bit Name	Value	Description
15 to 0	Break address BAMA15–BAMA0	0	Channel A break address BAA _n is included in the break conditions (Initial value)
		1	Channel A break address BAA _n is not included in the break conditions

n = 15 to 0

Break bus cycle register A (BBRA)	H'FFFFFF48	16/32
-----------------------------------	------------	-------

Item	Bit															
	15	14	13	12	11	10	9	8	7	6	5	4	3	2	1	0
Bit Name	—	—	—	—	—	—	—	—	CPA	CPA	IDA1	IDA0	RWA	RW	SZA	SZA
Initial Value	0	0	0	0	0	0	0	0	1	0			1	A0	1	0
R/W	R	R	R	R	R	R	R	R	R/W	R/W	R/W	R/W	R/W	R/W	R/W	R/W

Bit	Bit Name	Value	Description
7, 6	CPU cycle/peripheral cycle select A (CPA1, CPA0)	0 0	No channel A user break interrupt generated (Initial value)
		0 1	Break only on CPU cycles
		1 0	Break only on peripheral cycles
		1 1	Break on both CPU and peripheral cycles
5, 4	Instruction fetch/data access select A (IDA1, IDA0)	0 0	No channel A user break interrupt generated (Initial value)
		0 1	Break only on instruction fetch cycles
		1 0	Break only on data access cycles
		1 1	Break on both instruction fetch and data access cycles
3, 2	Read/write select A (RWA1, RWA0)	0 0	No channel A user break interrupt generated (Initial value)
		0 1	Break only on read cycles
		1 0	Break only on write cycles
		1 1	Break on both read and write cycles
1, 0	Operand size select A (SZA1, SZA0)	0 0	Operand size is not a break condition (Initial value)
		0 1	Break on byte access
		1 0	Break on word access
		1 1	Break on longword access

Break address register BH (BARBH)	H'FFFFFF60	16/32
-----------------------------------	------------	-------

Item	Bit															
	15	14	13	12	11	10	9	8	7	6	5	4	3	2	1	0
Bit Name	BAB	BAB	BAB	BAB	BAB	BAB	BAB	BAB	BAB	BAB	BAB	BAB	BAB	BAB	BAB	BAB
Initial Value	0	0	0	0	0	0	0	0	0	0	0	0	0	0	0	0
R/W	R/W	R/W	R/W	R/W	R/W	R/W	R/W	R/W	R/W	R/W	R/W	R/W	R/W	R/W	R/W	R/W

Bit	Bit Name	Description
15 to 0	Break address BAB31–BAB16	These bits specify the upper bits (bit 31 to bit 16) of the channel B break condition address

Break address register BL (BARBL)	H'FFFFFF62	16
-----------------------------------	------------	----

Item	Bit															
	15	14	13	12	11	10	9	8	7	6	5	4	3	2	1	0
Bit Name	BAB 15	BAB 14	BAB 13	BAB 12	BAB 11	BAB 10	BAB 9	BAB 8	BAB 7	BAB 6	BAB 5	BAB 4	BAB 3	BAB 2	BAB 1	BAB 0
Initial Value	0	0	0	0	0	0	0	0	0	0	0	0	0	0	0	0
R/W	R/W	R/W	R/W	R/W	R/W	R/W	R/W	R/W	R/W	R/W	R/W	R/W	R/W	R/W	R/W	R/W

Bit	Bit Name	Description
15 to 0	Break address BAB15–BAB0	These bits specify the lower bits (bit 15 to bit 0) of the channel B break condition address

Break address mask register BH (BAMRBH)	H'FFFFFF64	16/32
---	------------	-------

Item	Bit															
	15	14	13	12	11	10	9	8	7	6	5	4	3	2	1	0
Bit Name	BAM B31	BAM B30	BAM B29	BAM B28	BAM B27	BAM B26	BAM B25	BAM B24	BAM B23	BAM B22	BAM B21	BAM B20	BAM B19	BAM B18	BAM B17	BAM B16
Initial Value	0	0	0	0	0	0	0	0	0	0	0	0	0	0	0	0
R/W	R/W	R/W	R/W	R/W	R/W	R/W	R/W	R/W	R/W	R/W	R/W	R/W	R/W	R/W	R/W	R/W

Bit	Bit Name	Value	Description
15 to 0	Break address mask BAMB31–BAMB16	0	Channel B break address BABn is included in the break conditions (Initial value)
		1	Channel B break address BABn is not included in the break conditions

n = 31 to 16

Break address mask register BL (BAMRBL)	H'FFFFFF66	16
---	------------	----

Item	Bit															
	15	14	13	12	11	10	9	8	7	6	5	4	3	2	1	0
Bit Name	BAM B15	BAM B14	BAM B13	BAM B12	BAM B11	BAM B10	BAM B9	BAM B8	BAM B7	BAM B6	BAM B5	BAM B4	BAM B3	BAM B2	BAM B1	BAM B0
Initial Value	0	0	0	0	0	0	0	0	0	0	0	0	0	0	0	0
R/W	R/W	R/W	R/W	R/W	R/W	R/W	R/W	R/W	R/W	R/W	R/W	R/W	R/W	R/W	R/W	R/W

Bit	Bit Name	Value	Description
15 to 0	Break address mask BAMB15–BAMB0	0	Channel B break address BAB _n is included in the break conditions (Initial value)
		1	Channel B break address BAB _n is not included in the break conditions

n = 15 to 0

Break data register BH (BDRBH)	H'FFFFFF70	16/32
--------------------------------	------------	-------

Item	Bit															
	15	14	13	12	11	10	9	8	7	6	5	4	3	2	1	0
Bit Name	BDB 31	BDB 30	BDB 29	BDB 28	BDB 27	BDB 26	BDB 25	BDB 24	BDB 23	BDB 22	BDB 21	BDB 20	BDB 19	BDB 18	BDB 17	BDB 16
Initial Value	0	0	0	0	0	0	0	0	0	0	0	0	0	0	0	0
R/W	R/W	R/W	R/W	R/W	R/W	R/W	R/W	R/W	R/W	R/W	R/W	R/W	R/W	R/W	R/W	R/W

Bit	Bit Name	Description
15 to 0	Break data BDB31–BDB16	These bits specify the upper bits (bit 31 to bit 16) of the channel B break condition data

Break data register BL (BDRBL)	H'FFFFFF72	16/32
--------------------------------	------------	-------

Item	Bit															
	15	14	13	12	11	10	9	8	7	6	5	4	3	2	1	0
Bit Name	BDB	BDB	BDB	BDB	BDB	BDB	BDB	BDB	BDB	BDB	BDB	BDB	BDB	BDB	BDB	BDB
Initial Value	0	0	0	0	0	0	0	0	0	0	0	0	0	0	0	0
R/W	R/W	R/W	R/W	R/W	R/W	R/W	R/W	R/W	R/W	R/W	R/W	R/W	R/W	R/W	R/W	R/W

Bit	Bit Name	Description
15 to 0	Break data BDB15–BDB0	These bits specify the lower bits (bit 15 to bit 0) of the channel B break condition data

Break data mask register BH (BDMRBH)	H'FFFFFF74	16/32
--------------------------------------	------------	-------

Item	Bit															
	15	14	13	12	11	10	9	8	7	6	5	4	3	2	1	0
Bit Name	BDM	BDM	BDM	BDM	BDM	BDM	BDM	BDM	BDM	BDM	BDM	BDM	BDM	BDM	BDM	BDM
Initial Value	0	0	0	0	0	0	0	0	0	0	0	0	0	0	0	0
R/W	R/W	R/W	R/W	R/W	R/W	R/W	R/W	R/W	R/W	R/W	R/W	R/W	R/W	R/W	R/W	R/W

Bit	Bit Name	Value	Description
15 to 0	Break data mask BDMB31–BDMB16	0	Channel B break address BDBn is included in the break conditions (Initial value)
		1	Channel B break address BDBn is masked and therefore not included in the break conditions

n = 31 to 16

Break data mask register BL (BDMRBL)	H'FFFFFF76	16
--------------------------------------	------------	----

Item	Bit															
	15	14	13	12	11	10	9	8	7	6	5	4	3	2	1	0
Bit Name	BDM B15	BDM B14	BDM B13	BDM B12	BDM B11	BDM B10	BDM B9	BDM B8	BDM B7	BDM B6	BDM B5	BDM B4	BDM B3	BDM B2	BDM B1	BDM B0
Initial Value	0	0	0	0	0	0	0	0	0	0	0	0	0	0	0	0
R/W	R/W	R/W	R/W	R/W	R/W	R/W	R/W	R/W	R/W	R/W	R/W	R/W	R/W	R/W	R/W	R/W

Bit	Bit Name	Value	Description
15 to 0	Break data mask BDMB15–BDMB0	0	Channel B break address BDBn is included in the break conditions (Initial value)
		1	Channel B break address BDBn is masked and therefore not included in the break conditions

n = 15 to 0

Break bus cycle register B (BBRB)	H'FFFFFF68	16/32
-----------------------------------	------------	-------

Item	Bit															
	15	14	13	12	11	10	9	8	7	6	5	4	3	2	1	0
Bit Name	—	—	—	—	—	—	—	—	CPB	CPB	IDB	IDB	RWB	RWB	SZB	SZB
Initial Value	0	0	0	0	0	0	0	0	0	0	0	0	0	0	0	0
R/W	R	R	R	R	R	R	R	R	R/W	R/W	R/W	R/W	R/W	R/W	R/W	R/W

Bit	Bit Name	Value	Description
7, 6	CPU cycle/peripheral cycle select B (CPB1, CPB0)	0 0	No channel B user break interrupt generated (Initial value)
		0 1	Break only on CPU cycles
		1 0	Break only on peripheral cycles
		1 1	Break on both CPU and peripheral cycles
5, 4	Instruction fetch/data access select B (IDB1, IDB0)	0 0	No channel B user break interrupt generated (Initial value)
		0 1	Break only on instruction fetch cycles
		1 0	Break only on data access cycles
		1 1	Break on both instruction fetch and data access cycles
3, 2	Read/write select B (RWB1, RWB0)	0 0	No channel B user break interrupt generated (Initial value)
		0 1	Break only on read cycles
		1 0	Break only on write cycles
		1 1	Break on both read and write cycles
1, 0	Operand size select B (SZB1, SZB0)	0 0	Operand size is not a break condition (Initial value)
		0 1	Break on byte access
		1 0	Break on word access
		1 1	Break on longword access

Break control register (BRCR)	H'FFFFFF78	16/32
-------------------------------	------------	-------

Bit

Item	Bit															
	15	14	13	12	11	10	9	8	7	6	5	4	3	2	1	0
Bit Name	CMF CA	CMF PA	EBBE	UMD	—	PCBA	—	—	CMF CB	CMF PB	—	SEQ	DBEB	PCBB	—	—
Initial Value	0	0	0	0	0	0	0	0	0	0	0	0	0	0	0	0
R/W	R/W	R/W	R/W	R/W	R	R/W	R	R	R/W	R/W	R	R/W	R/W	R/W	R	R

Bit	Bit Name	Value	Description
15	CPU condition match flag A (CMFCA)	0	Channel A CPU cycle conditions do not match, no user break interrupt generated (Initial value)
		1	Channel A CPU cycle conditions have matched, user break interrupt generated
14	Peripheral condition match flag A (CMFPA)	0	Channel A peripheral cycle conditions do not match, no user break interrupt generated (Initial value)
		1	Channel A peripheral cycle conditions have matched, user break interrupt generated
13	External bus break enable (EBBE)	0	Chip-external bus cycle not included in break conditions (Initial value)
		1	Chip-external bus cycle included in break conditions
12	UBC mode (UMD)	0	Compatible mode for SH7000-series UBCs (Initial value)
		1	SH7604 mode
10	PC break select A (PCBA)	0	Places the channel A instruction fetch cycle break before instruction execution (Initial value)
		1	Places the channel A instruction fetch cycle break after instruction execution
7	CPU condition match flag B (CMFCB)	1	Channel B CPU cycle conditions do not match, no user break interrupt generated (Initial value)
		0	Channel B CPU cycle conditions have matched, user break interrupt generated
6	Peripheral condition match flag B (CMFPB)	0	Channel B peripheral cycle conditions do not match, no user break interrupt generated (Initial value)
		1	Channel B peripheral cycle conditions have matched, user break interrupt generated
4	Sequence condition select (SEQ)	0	Compare channel A and B conditions independently (Initial value)
		1	Compare channel A and B conditions sequentially (channel A, then channel B)
3	Data break enable B (DBEB)	0	Do not include data bus conditions in the channel B conditions (Initial value)
		1	Include data bus conditions in the channel B conditions
2	Instruction break select B (PCBB)	0	Places the channel B instruction fetch cycle break before instruction execution (Initial value)
		1	Places the channel B instruction fetch cycle break after instruction execution

DMA source address registers 0 and 1 (SAR0 and SAR1)	H'FFFFFF80 (channel 0) H'FFFFFF90 (channel 1)	32
--	--	----

Bit

Item	31	30	29	28	27	26	25	24	23	22	21	20	19	18	17	16
Bit Name																
Initial Value	—	—	—	—	—	—	—	—	—	—	—	—	—	—	—	—
R/W	R/W	R/W	R/W	R/W	R/W	R/W	R/W	R/W	R/W	R/W	R/W	R/W	R/W	R/W	R/W	R/W
Item	15	14	13	12	11	10	9	8	7	6	5	4	3	2	1	0
Bit Name																
Initial Value	—	—	—	—	—	—	—	—	—	—	—	—	—	—	—	—
R/W	R/W	R/W	R/W	R/W	R/W	R/W	R/W	R/W	R/W	R/W	R/W	R/W	R/W	R/W	R/W	R/W

Bit

Bit Name

Description

31 to 0	(Transfer source address specification)	These bits specify the DMA transfer source address
---------	---	--

DMA destination address registers 0 and 1 (DAR0 and DAR1)	H'FFFFFF84 (channel 0) H'FFFFFF94 (channel 1)	32
---	--	----

DataSheet4U Bit

Item	31	30	29	28	27	26	25	24	23	22	21	20	19	18	17	16
Bit Name																
Initial Value	—	—	—	—	—	—	—	—	—	—	—	—	—	—	—	—
R/W	R/W	R/W	R/W	R/W	R/W	R/W	R/W	R/W	R/W	R/W	R/W	R/W	R/W	R/W	R/W	R/W
Item	15	14	13	12	11	10	9	8	7	6	5	4	3	2	1	0
Bit Name																
Initial Value	—	—	—	—	—	—	—	—	—	—	—	—	—	—	—	—
R/W	R/W	R/W	R/W	R/W	R/W	R/W	R/W	R/W	R/W	R/W	R/W	R/W	R/W	R/W	R/W	R/W

Bit

Bit Name

Description

31 to 0	(Transfer destination address specification)	These bits specify the DMA transfer destination address
---------	--	---

DMA transfer count registers 0 and 1 (TCR0 and TCR1)	H'FFFFFF88 (channel 0) H'FFFFFF98 (channel 1)	32
--	--	----

Item	Bit															
	31	30	29	28	27	26	25	24	23	22	21	20	19	18	17	16
Bit Name	—	—	—	—	—	—	—	—	—	—	—	—	—	—	—	—
Initial Value	0	0	0	0	0	0	0	0	—	—	—	—	—	—	—	—
R/W	R	R	R	R	R	R	R	R	R/W	R/W	R/W	R/W	R/W	R/W	R/W	R/W
Item	15	14	13	12	11	10	9	8	7	6	5	4	3	2	1	0
Bit Name	—	—	—	—	—	—	—	—	—	—	—	—	—	—	—	—
Initial Value	—	—	—	—	—	—	—	—	—	—	—	—	—	—	—	—
R/W	R/W	R/W	R/W	R/W	R/W	R/W	R/W	R/W	R/W	R/W	R/W	R/W	R/W	R/W	R/W	R/W

Bit	Bit Name	Description
23 to 0	(Transfer count specification)	Specifies the DMA transfer count (during a DMA transfer, these bits indicate the remaining transfer count)

DMA channel control registers 0, 1 (CHCR0, CHCR1)	H'FFFFFF8C (channel 0) H'FFFFFF9C (channel 1)	32
---	--	----

Item	DataSheet4U. Bit															
	31	30	29	28	27	26	25	24	23	22	21	20	19	18	17	16
Bit Name	—	—	—	—	—	—	—	—	—	—	—	—	—	—	—	—
Initial Value	0	0	0	0	0	0	0	0	0	0	0	0	0	0	0	0
R/W	R	R	R	R	R	R	R	R	R	R	R	R	R	R	R	R
Item	15	14	13	12	11	10	9	8	7	6	5	4	3	2	1	0
Bit Name	DM1	DM0	SM1	SM0	TS1	TS0	AR	AM	AL	DS	DL	TB	TA	IE	TE	DE
Initial Value	0	0	0	0	0	0	0	0	0	0	0	0	0	0	0	0
R/W	R/W	R/W	R/W	R/W	R/W	R/W	R/W	R/W	R/W	R/W	R/W	R/W	R/W	R/W	R/W	R/W

Note: Only 0 can be written, after reading 1, to clear the flag.

Bit	Bit Name	Value	Description
14, 15	Destination address mode bits 1, 0 (DM1, DM0)	0 0	Fixed destination address (Initial value)
		0 1	Destination address is incremented (+1 for byte transfer size, +2 for word transfer size, +4 for longword transfer size, and +16 for 16-byte transfer size)
		1 0	Destination address is decremented (−1 for byte transfer size, −2 for word transfer size, −4 for longword transfer size, and −16 for 16-byte transfer size)
		1 1	Reserved (setting prohibited)

Bit	Bit Name	Value	Description
13, 12	Source address mode bits 1, 0 (SM1, SM0)	0 0	Fixed source address (+16 for 16-byte transfer size) (Initial value)
		0 1	Source address is incremented (+1 for byte transfer size, +2 for word transfer size, +4 for longword transfer size, and +16 for 16-byte transfer size)
		1 0	Source address is decremented (−1 for byte transfer size, −2 for word transfer size, −4 for longword transfer size, and +16 for 16-byte transfer size)
		1 1	Reserved (setting prohibited)
11, 10	Transfer size bits 1, 0 (TS1, TS0)	0	Byte unit (Initial value)
		0	Word (2-byte) unit
		1	Longword (4-byte) unit
		1	16-byte unit (4 longword transfers)
9	Auto-request mode bit (AR)	0	Module request mode (Initial value)
		1	Auto-request mode
8	Acknowledge/transfer mode bit (AM)	0	DACK output in read cycle/transfer from memory to device (Initial value)
		1	DACK output in write cycle/transfer from device to memory
7	Acknowledge level bit (AL)	0	DACK is an active-low signal (Initial value)
		1	DACK is an active-high signal
6	DREQ select bit (DS)	0	Detected by level (Initial value)
		1	Detected by edge
5	DREQ level bit (DL)	0	When DS is 0, DREQ is detected by low level; when DS is 1, DREQ is detected by fall (Initial value)
		1	When DS is 0, DREQ is detected by high level; when DS is 1, DREQ is detected by rise
4	Transfer bus mode bit (TB)	0	Cycle-steal mode
		1	Burst mode
3	Transfer address mode bit (TA)	0	Dnal address mode
		1	Single address mode
2	Interrupt enable bit (IE)	0	Interrupt disabled (Initial value)
		1	Interrupt enabled
1	Transfer-end flag bit (TE)	0	DMA has not ended or was aborted (Initial value) Cleared by reading 1 from the TE bit and then writing 0
		1	DMA has ended normally (by TCR = 0)
0	DMA enable bit (DE)	0	DMA transfer disabled (Initial value)
		1	DMA transfer enabled

DMA request/response selection control registers 0 and 1 (DRCR0, DRCR1)	H'FFFFFFE71 (channel 0) H'FFFFFFE72 (channel 1)	8
---	--	---

Item	Bit							
	7	6	5	4	3	2	1	0
Bit Name	—	—	—	—	—	—	RS1	RS0
Initial Value	0	0	0	0	0	0	0	0
R/W	R	R	R	R	R	R	R/W	R/W

Bit	Bit Name	Value	Description
1, 0	Resource select bits 1, 0 (RS1, RS0)	0 0	DREQ (external request) (Initial value)
		0 1	RXI (receive-data-full interrupt transfer request of the on-chip serial communication interface (SCI))
		1 0	TXI (transmit-data-full interrupt transfer request of the on-chip SCI)
		1 1	Reserved (setting prohibited)

DMA operation register (DMAOR)	H'FFFFFFB0	32
--------------------------------	------------	----

Item	Bit															
	31	30	29	28	27	26	25	24	23	22	21	20	19	18	17	16
Bit Name	—	—	—	—	—	—	—	—	—	—	—	—	—	—	—	—
Initial Value	0	0	0	0	0	0	0	0	0	0	0	0	0	0	0	0
R/W	R	R	R	R	R	R	R	R	R	R	R	R	R	R	R	R
Item	15	14	13	12	11	10	9	8	7	6	5	4	3	2	1	0
Bit Name	—	—	—	—	—	—	—	—	—	—	—	—	PR	AE	NMIF	DME
Initial Value	0	0	0	0	0	0	0	0	0	0	0	0	0	0	0	0
R/W	R	R	R	R	R	R	R	R	R	R	R	R	R/W	R/ (W)*	R/ (W)*	R/W

Note: Only 0 can be written, to clear the flag.

Bit	Bit Name	Value	Description
3	Priority mode bit (PR)	0	Fixed priority (Ch 0 > Ch 1) (Initial value)
		1	Round-robin mode (High priority switches to low after each transfer) (The priority for the first DMA transfer after a reset is Ch 1 > Ch 0)
2	Address error flag bit (AE)	0	No DMAC address error (Initial value)
		1	Address error by DMAC
1	NMI flag bit (NMIF)	0	No NMIF interrupt (Initial value) To clear the NMIF bit, read 1 from it and then write 0
		1	NMIF has occurred
0	DMA master enable bit (DME)	0	DMA transfers disabled on all channels (Initial value)
		1	DMA transfers enabled on all channels

Bus control register 1 (BCR1)	H'FFFFFFE0	16/32
-------------------------------	------------	-------

Item	Bit															
	15	14	13	12	11	10	9	8	7	6	5	4	3	2	1	0
Bit Name	MAS			END	BST	PSHR	AHLW	AHLW	A1LW	A1LW	A0LW	A0LW		DRAM	DRAM	DRAM
	TER	—	—	IAN	ROM		1	0	1	0	1	0	—	2	1	0
Initial Value	—	0	0	0	0	0	1	1	1	1	1	1	0	0	0	0
R/W	R	R	R	R/W	R/W	R/W	R/W	R/W	R/W	R/W	R/W	R/W	R	R/W	R/W	R/W

Bit	Bit Name	Value	Description
15	Bus arbitration (MASTER)	0	Master mode
		1	Slave mode
12	Endian specification for area 2 (ENDIAN)	0	Big-endian, as in other areas (Initial value)
		1	Little-endian
11	Area 0 burst ROM enable (BSTROM)	0	Area 0 is accessed normally (Initial value)
		1	Area 0 is accessed as burst ROM
10	Partial space share specification (PSHR)	0	Total master mode when MD5 = 0 (Initial mode)
		1	Partial-share master mode when MD5 = 0
9, 8	Long wait specification for areas 2 and 3 (AHLW1, AHLW0)	0 0	3 waits (Initial value)
		0 1	4 waits
		1 0	5 waits
		1 1	6 waits
7, 6	Long wait specification for area 1 (A1LW1, A1LW0)	0 0	3 waits (Initial value)
		0 1	4 waits
		1 0	5 waits
		1 1	6 waits
5, 4	Long wait specification for area 0 (A0LW1, A0LW0)	0 0	3 waits (Initial value)
		0 1	4 waits
		1 0	5 waits
		1 1	6 waits
2 to 0	Enable for DRAM and other memory (DRAM2-DRAM0)	0 0 0	Areas 2 and 3 are ordinary spaces (Initial value)
		0 0 1	Area 2 is ordinary space; area 3 is synchronous DRAM space
		0 1 0	Area 2 is ordinary space; area 3 is DRAM space
		0 1 1	Area 2 is ordinary space; area 3 is pseudo-SRAM space
		1 0 0	Area 2 is synchronous DRAM space; area 3 is ordinary space
		1 0 1	Areas 2 and 3 are synchronous DRAM spaces
		1 1 0	Reserved (setting prohibited)
		1 1 1	Reserved (setting prohibited)

Bus control register 2 (BCR2)	H'FFFFFFE4	16/32
-------------------------------	------------	-------

Item	Bit															
	15	14	13	12	11	10	9	8	7	6	5	4	3	2	1	0
Bit Name	—	—	—	—	—	—	—	—	A3	A3	A2	A2	A1	A1	—	—
Initial Value	0	0	0	0	0	0	0	0	1	1	1	1	1	1	0	0
R/W	R	R	R	R	R	R	R	R	R/W	R/W	R/W	R/W	R/W	R/W	R	R

Bit	Bit Name	Value	Description
7, 6	Bus size specification for area 3 (A3SZ1–A3SZ0)(Valid only when setting ordinary space)	0 0	Reserved (setting prohibited)
		0 1	Byte (8-bit) size
		1 0	Word (16-bit) size
		1 1	Longword (32-bit) size (Initial value)
5, 4	Bus size specification for area 2 (A2SZ1–A2SZ0) (Valid only when setting ordinary space)	0 0	Reserved (setting prohibited)
		0 1	Byte (8-bit) size
		1 0	Word (16-bit) size
		1 1	Longword (32-bit) size (Initial value)
3, 2	Bus size specification for area 1 (A1SZ1–A1SZ0)	0 0	Reserved (setting prohibited)
		0 1	Byte (8-bit) size
		1 0	Word (16-bit) size
		1 1	Longword (32-bit) size (Initial value)

Wait control register (WCR)	H'FFFFFFE8	16/32
-----------------------------	------------	-------

Item	Bit															
	15	14	13	12	11	10	9	8	7	6	5	4	3	2	1	0
Bit Name	IW31	IW30	IW21	IW20	IW11	IW10	IW01	IW00	W31	W30	W21	W20	W11	W10	W01	W00
Initial Value	1	0	1	0	1	0	1	0	1	1	1	1	1	1	1	1
R/W	R/W	R/W	R/W	R/W	R/W	R/W	R/W	R/W	R/W	R/W	R/W	R/W	R/W	R/W	R/W	R/W

Bit	Bit Name	Value	Description
15 to 8	Idles between cycles for areas 3 to 0 (IW31–IW00)	IW31 IW30 IW21 IW20 IW11 IW10 IW01 IW00	
		0 0	No idle cycle
		0 1	One idle cycle inserted
		1 0	Two idle cycles inserted (Initial value)
		1 1	Reserved (setting prohibited)

Bit	Bit Name	Value	Description
7 to 0	Wait control of areas 3 to 0 (W31–W00)	During basic cycle	
		W31 W30	
		W21 W20	
		W11 W10	
		W01 W00	
		0 0	External wait input disabled without waits
		0 1	External wait input enabled with one wait
		1 0	External wait input enabled with two waits
		1 1	Complies with the long wait specification of bus control register 1 (BCR1) External wait input is enabled (Initial value)
		When area 3 is DRAM	
		W31 W30	
		0 0	1 CAS assert cycle
		0 1	2 CAS assert cycles
		1 0	3 CAS assert cycles
		1 1	Reserved (setting prohibited)
		When area 2 or 3 is synchronous DRAM	
		W31 W30	
		W21 W20	
		0 0	1 CAS latency cycle
		0 1	2 CAS latency cycles
		1 0	3 CAS latency cycles
		1 1	4 CAS latency cycles (Initial value)
		When area 3 is pseudo-SRAM	
		W31 W30	
		0 0	2 cycles from BS signal assertion to end of cycle
		0 1	3 cycles from BS signal assertion to end of cycle
		1 0	4 cycles from BS signal assertion to end of cycle
		1 1	Reserved (setting prohibited)

Individual memory control register (MCR)	H'FFFFFFEC	16/32
--	------------	-------

Item	Bit																			
	15	14	13	12	11	10	9	8	7	6	5	4	3	2	1	0				
Bit Name	TRP		RCD	TRWL		TRAS		1	0	BE	RASD	—	AMX2	SZ	AMX1	AMX0	RFSH	RMD	—	—
Initial Value	0	0	0	0	0	0	0	0	0	0	0	0	0	0	0	0	0	0	0	0
R/W	R/W	R/W	R/W	R/W	R/W	R/W	R/W	R/W	R	R/W	R/W	R/W	R/W	R/W	R/W	R/W	R/W	R	R	

Bit	Bit Name	Value	Description
15	RAS precharge time (TRP)	0	1 cycle (Initial value)
		1	2 cycles
14	RAS-CAS delay (RCD)	0	1 cycle (Initial value)
		1	2 cycles
13	Write-precharge delay (TRWL)	0	1 cycle (Initial value)
		1	2 cycles
12, 11	CAS-before-RAS refresh RAS assert time (TRAS1, TRAS0)	0 0	2 cycles (Initial value)
		0 1	3 cycles
		1 0	4 cycles
		1 1	Reserved (setting prohibited)
10	Burst enable (BE)	0	Burst disabled (Initial value)
		1	High-speed page mode during DRAM interface is enabled. Data is continuously transferred in static column mode during pseudo-SRAM interfacing. During synchronous DRAM access, burst is always enabled regardless of this bit.
9	Bank active mode (RASD)	0	For synchronous DRAM, read or write is performed using auto-precharge mode. The next access always starts with a bank active command.
		1	For synchronous DRAM, access ends with bank active status. This is only valid for area 3. When area 2 is synchronous DRAM, the mode is always auto-precharge.

DataSheet4U.com

Bit	Bit Name	Value	Description
7, 5, 4	Address multiplex (AMX2–AMX0)	For DRAM interface	
		0 0 0	8-bit column address DRAM (Initial value)
		0 0 1	9-bit column address DRAM
		0 1 0	10-bit column address DRAM
		0 1 1	11-bit column address DRAM
		1 0 0	Reserved (setting prohibited)
		1 0 1	Reserved (setting prohibited)
		1 1 0	Reserved (setting prohibited)
		1 1 1	Reserved (setting prohibited)
		For synchronous DRAM interface	
		0 0 0	16-Mbit DRAM (1M × 16 bits) (Initial value)
		0 0 1	16-Mbit DRAM (2M × 8 bits)
		0 1 0	16-Mbit DRAM (4M × 4 bits)
		0 1 1	4-Mbit DRAM (256k × 16 bits)
		1 0 0	Reserved (setting prohibited)
		1 0 1	Reserved (setting prohibited)
1 1 0	Reserved (setting prohibited)		
1 1 1	2-Mbit DRAM (128k × 16 bits)		
6	Memory data size (SZ)	0	Word (Initial value)
		1	Longword
3	Refresh control (RFSH)	0	No refresh (Initial value)
		1	Refresh
2	Refresh mode (RMODE)	0	Normal refresh (Initial value)
		1	Self-refresh

Refresh timer control/status register (RTCSR)	H'FFFFFFF0	16/32
---	------------	-------

Bit

Item	15	14	13	12	11	10	9	8	7	6	5	4	3	2	1	0	
Bit Name	—	—	—	—	—	—	—	—	—	CMF	CMIE	CKS2	CKS1	CKS0	—	—	—
Initial Value	0	0	0	0	0	0	0	0	0	0	0	0	0	0	0	0	0
R/W	R	R	R	R	R	R	R	R	R	R/W	R/W	R/W	R/W	R/W	R	R	R

Bit	Bit Name	Value	Description
7	Compare match flag (CMF)	—	RTCNT and RTCOR match Clear condition: After RTCSR is read when CMF is 1, 0 is written in CMF
6	Compare match interrupt enable (CMIE)	0	Disables interrupt request caused by CMF (Initial value)
		1	Enables interrupt request caused by CMF
5 to 3	Clock select bits (CKS2–CKS0)	0 0 0	Disables count up (Initial value)
		0 0 1	CLK/4
		0 1 0	CLK/16
		0 1 1	CLK/64
		1 0 0	CLK/256
		1 0 1	CLK/1024
		1 1 0	CLK/2048
		1 1 1	CLK/4096

DataSheet4U.com

Refresh timer counter (RTCNT)	H'FFFFFFF4	16/32
-------------------------------	------------	-------

Bit

Item	15	14	13	12	11	10	9	8	7	6	5	4	3	2	1	0
Bit Name	—	—	—	—	—	—	—	—	—	—	—	—	—	—	—	—
Initial Value	0	0	0	0	0	0	0	0	0	0	0	0	0	0	0	0
R/W	R	R	R	R	R	R	R	R	R	R/W	R/W	R/W	R/W	R/W	R/W	R/W

Bit	Bit Name	Description
7 to 0	(Count value)	Input clock count value

Refresh time constant register (RTCOR)	H'FFFFFFF8	16/32
--	------------	-------

Bit

Item	15	14	13	12	11	10	9	8	7	6	5	4	3	2	1	0
Bit Name	—	—	—	—	—	—	—	—	—	—	—	—	—	—	—	—
Initial Value	0	0	0	0	0	0	0	0	0	0	0	0	0	0	0	0
R/W	R	R	R	R	R	R	R	R	R	R/W	R/W	R/W	R/W	R/W	R/W	R/W

Bit	Bit Name	Description	www.DataSheet4U.com
7 to 0	(Timer constant)	Sets the refresh cycle	

Cache control register (CCR)	H'FFFFFFE92	8
------------------------------	-------------	---

Item	Bit							
	7	6	5	4	3	2	1	0
Bit Name	W1	W0	—	CP	TW	OD	ID	CE
Initial Value	0	0	0	0	0	0	0	0
R/W	R/W	R/W	R/W	R/W	R/W	R/W	R/W	R/W

Bit	Bit Name	Value	Description
7, 6	Way specification (W1, W0)	0 0	Way 0 (Initial value)
		0 1	Way 1
		1 0	Way 2
		1 1	Way 3
4	Cache purge (CP)	0	Normal operation (Initial value)
		1	Cache purge
3	Two-way mode (TW)	0	Four-way mode (Initial value)
		1	Two-way mode
2	Data replacement disable (OD)	0	Normal operation (Initial value)
		1	Data not replaced even when cache miss occurs in data access
1	Instruction replacement disable (ID)	0	Normal operation (Initial value)
		1	Data not replaced even when cache miss occurs in instruction fetch
0	Cache enable (CE)	0	Cache disabled (Initial value)
		1	Cache enabled

Standby control register (SBYCR)	H'FFFFFFE91	8
----------------------------------	-------------	---

Bit

Item	7	6	5	4	3	2	1	0
Bit Name	SBY	HIZ	—	MSTP4	MSTP3	MSTP2	MSTP1	MSTP0
Initial Value	0	0	0	0	0	0	0	0
R/W	R/W	R/W	—	R/W	R/W	R/W	R/W	R/W

Bit	Bit Name	Value	Description
7	Standby (SBY)	0	Executing SLEEP instruction puts the chip into sleep mode (Initial value)
		1	Executing SLEEP instruction puts the chip into standby mode
6	Port high impedance (HIZ)	0	Pin states held in standby mode (Initial value)
		1	Pins at high impedance in standby mode
4	Module stop 4 (MSTP4)	0	DMAC running (Initial value)
		1	Clock supply to DMAC halted
3	Module stop 3 (MSTP3)	0	MULT running (Initial value)
		1	Clock supply to MULT halted
2	Module stop 2 (MSTP2)	0	DIVU running (Initial value)
		1	Clock supply to DIVU halted
1	Module stop 1 (MSTP1)	0	FRT running (Initial value)
		1	Clock supply to FRT halted
0	Module stop 0 (MSTP0)	0	SCI running (Initial value)
		1	Clock supply to SCI halted

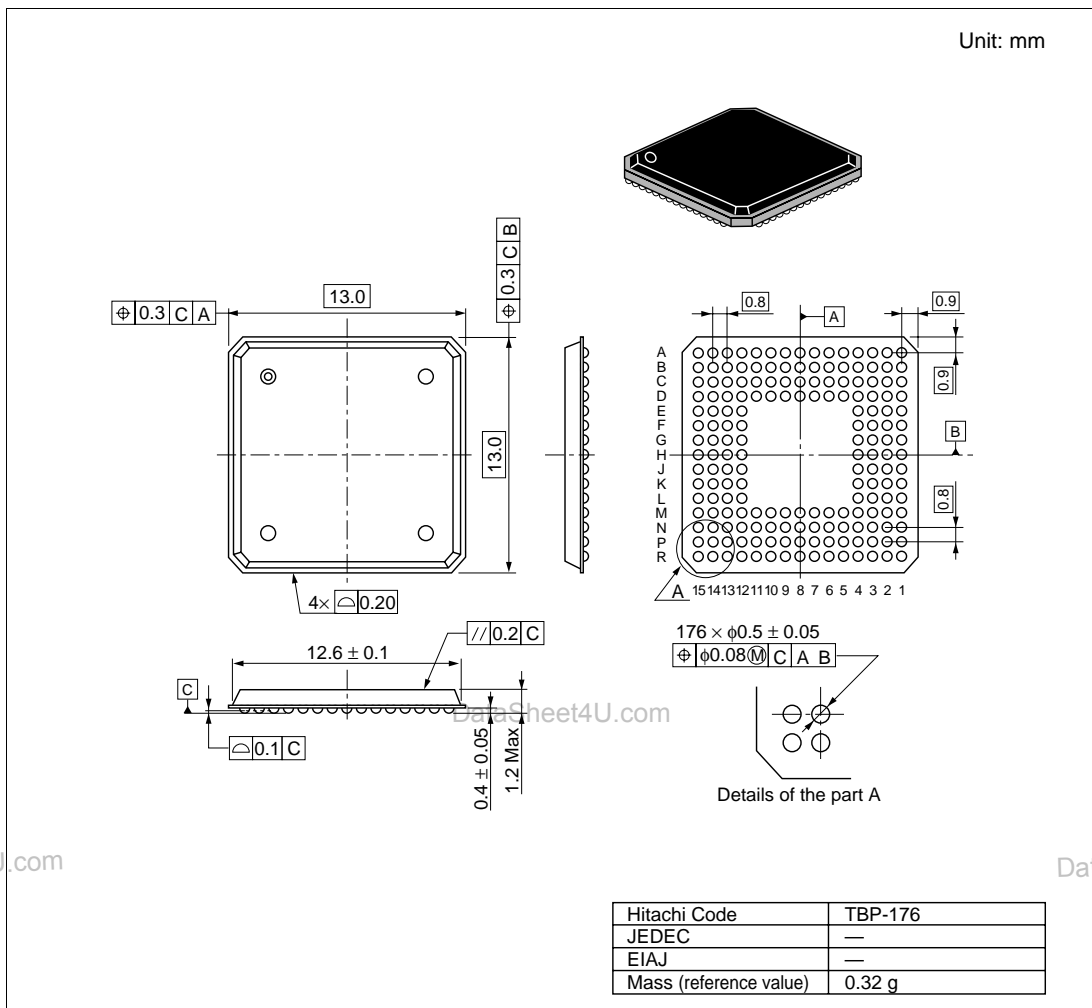

Figure C.2 External Dimensions

DataSheet4U.com

et4U.com

SH7604 Hardware Manual

Publication Date: 1st Edition, March 1995
4th Edition, September 2001

Published by: Customer Service Division
Hitachi, Ltd.

Edited by: Technical Documentation Center
Hitachi Kodaira Semiconductor Co., Ltd.

Copyright © Hitachi, Ltd., 1995. All rights reserved. Printed in Japan.