

INTRODUCTION

Fast, easy breadboarding of circuits using the PA60EU are possible with the PB80 PC board. Mounting holes are provided and the provision for standard banana jacks simplifies connection and testing. The amplifier may be mounted horizontally or vertically. Components are labeled on both sides of the board for ease in probing.

A multitude of circuit configurations are possible, so only several component locations have specific functions and will usually be necessary:

- C5, C8** Power supply bypasses **MUST** be used. Usually ceramic types of 0.01 to 1.0 μ F.
- C2, C9** Power supply bypass. Suggest 10 μ F per ampere of output current.
- R1** Feedback resistor.
- R3** Input resistor.
- R8, C10** Snubber network.
- R4, C7** Noise gain compensation. Necessary only occasionally, see Application Notes 19 and 25.

The following locations should be jumpered unless used (their most common anticipated function is listed).

- R2, R10** Input protection.
- CR1** V_{BOOST}
- R5, R6, R9** Output current sense.

The function of any other components is up to the designer's needs and imagination.

PA60EU CONSIDERATIONS:

When using the EK26 for the PA60EU the following components on the schematic below must be left either shorted or open:

- Short: R109, R209
- Open: CR101, C106, CR201, C206

EQUIVALENT SCHEMATIC

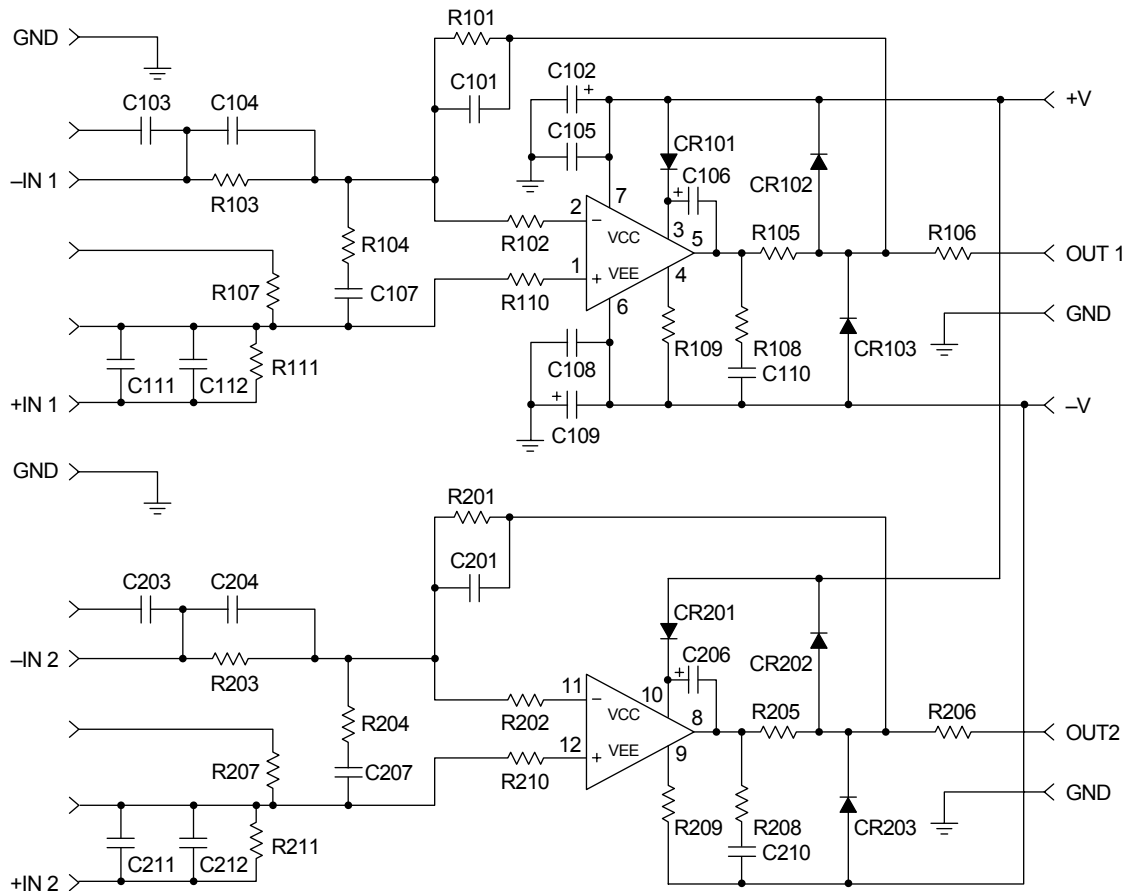

EK26

EVALUATION KIT
FOR PA60EU PIN-OUT

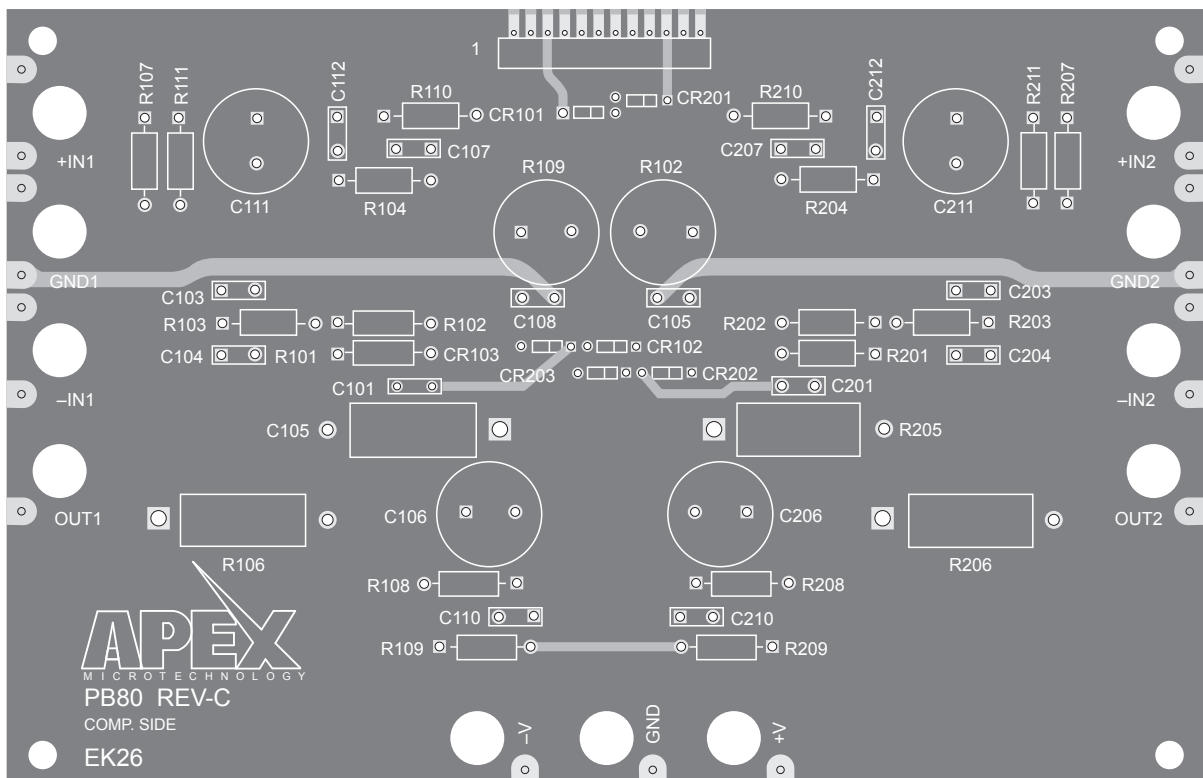
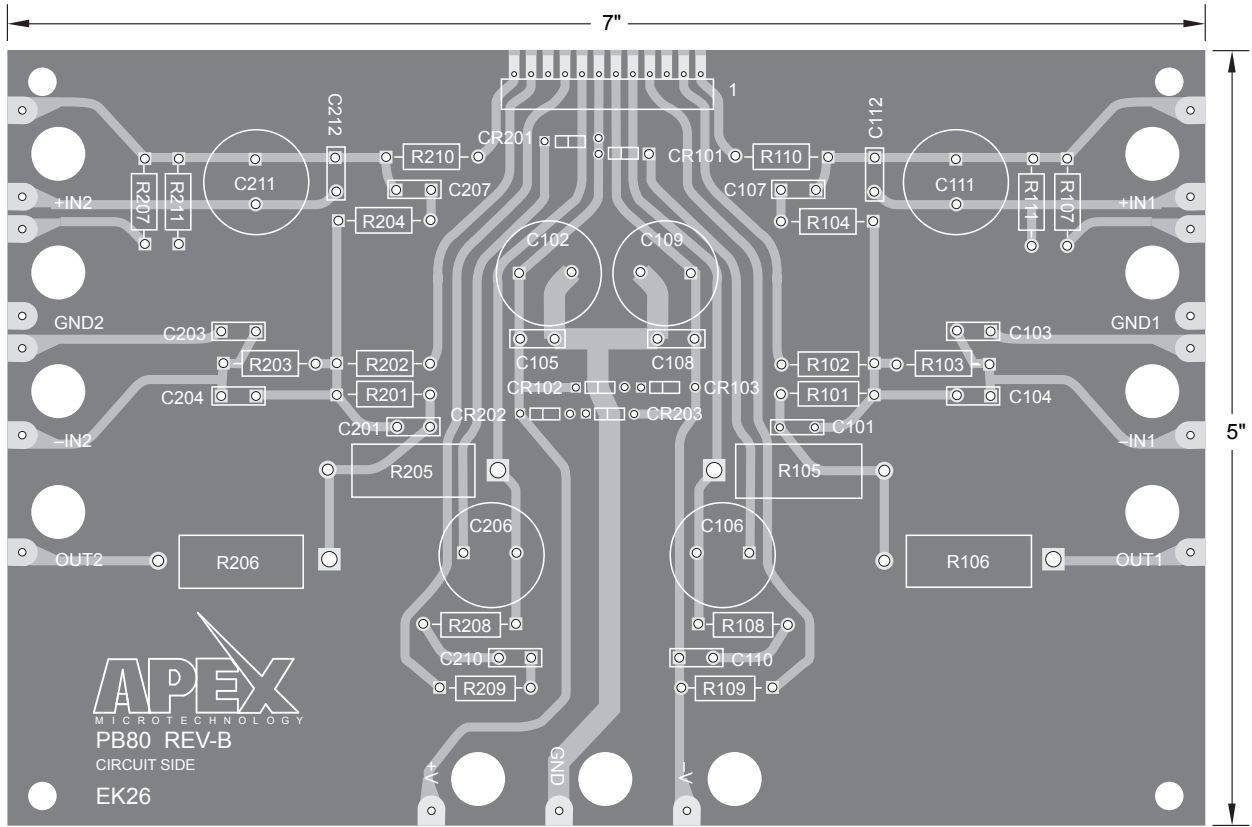

NOTE: Illustration only, not to scale.