



3 VOLT ADVANCED+ BOOT BLOCK 8-, 16-, 32-MBIT FLASH MEMORY FAMILY

28F008C3, 28F016C3, 28F032C3

28F800C3, 28F160C3, 28F320C3

- **Flexible SmartVoltage Technology**
 - 2.7 V–3.6 V Read/Program/Erase
 - 2.7 V or 1.65 V I/O Option Reduces Overall System Power
 - 12 V for Fast Production Programming
- **High Performance**
 - 2.7 V–3.6 V: 90 ns Max Access Time
 - 3.0 V–3.6 V: 80 ns Max Access Time
- **Optimized Architecture for Code Plus Data Storage**
 - Eight 8-Kbyte Blocks, Top or Bottom Locations
 - Up to Sixty-Three 64-KB Blocks
 - Fast Program Suspend Capability
 - Fast Erase Suspend Capability
- **Flexible Block Locking**
 - Lock/Unlock Any Block
 - Full Protection on Power-Up
 - WP# Pin for Hardware Block Protection
 - V_{PP} = GND Option
 - V_{CC} Lockout Voltage
- **Low Power Consumption**
 - 9 mA Typical Read Power
 - 10 μ A Typical Standby Power with Automatic Power Savings Feature
- **Extended Temperature Operation**
 - –40 °C to +85 °C
- **Easy-12 V**
 - Faster Production Programming
 - No Additional System Logic
- **128-bit Protection Register**
 - 64-bit Unique Device Identifier
 - 64-bit User Programmable OTP Cells
- **Extended Cycling Capability**
 - Minimum 100,000 Block Erase Cycles
- **Flash Data Integrator Software**
 - Flash Memory Manager
 - System Interrupt Manager
 - Supports Parameter Storage, Streaming Data (e.g., voice)
- **Automated Word/Byte Program and Block Erase**
 - Command User Interface
 - Status Registers
- **SRAM-Compatible Write Interface**
- **Cross-Compatible Command Support**
 - Intel Basic Command Set
 - Common Flash Interface
- **x 16 for High Performance**
 - 48-Ball μ BGA* Package
 - 48-Lead TSOP Package
- **x 8 I/O for Space Savings**
 - 48-Ball μ BGA* Package
 - 40-Lead TSOP Package
- **0.25 μ ETOX™ VI Flash Technology**

The 0.25 μ m 3 Volt Advanced+ Boot Block, manufactured on Intel's latest 0.25 μ technology, represents a feature-rich solution at overall lower system cost. Smart 3 flash memory devices incorporate low voltage capability (2.7 V read, program and erase) with high-speed, low-power operation. Flexible block locking allows any block to be independently locked or unlocked. Add to this the Intel-developed Flash Data Integrator (FDI) software and you have a cost-effective, flexible, monolithic code plus data storage solution on the market today. 3 Volt Advanced+ Boot Block products will be available in 48-lead TSOP, 40-lead TSOP, and 48-ball μ BGA* packages. Additional information on this product family can be obtained by accessing Intel's WWW page: <http://www.intel.com/design/flcomp>.

Information in this document is provided in connection with Intel products. No license, express or implied, by estoppel or otherwise, to any intellectual property rights is granted by this document. Except as provided in Intel's Terms and Conditions of Sale for such products, Intel assumes no liability whatsoever, and Intel disclaims any express or implied warranty, relating to sale and/or use of Intel products including liability or warranties relating to fitness for a particular purpose, merchantability, or infringement of any patent, copyright or other intellectual property right. Intel products are not intended for use in medical, life saving, or life sustaining applications.

Intel may make changes to specifications and product descriptions at any time, without notice.

The 28F008C3, 28F016C3, 28F032C3, 28F800C3, 28F160C3, 28F320C3 may contain design defects or errors known as errata which may cause the product to deviate from published specifications. Current characterized errata are available on request.

Contact your local Intel sales office or your distributor to obtain the latest specifications and before placing your product order.

Copies of documents which have an ordering number and are referenced in this document, or other Intel literature, may be obtained from:

Intel Corporation
P.O. Box 5937
Denver, CO 80217-9808
or call 1-800-548-4725
or visit Intel's website at <http://www.intel.com>

CONTENTS

	PAGE		PAGE
1.0 INTRODUCTION	5	3.4 128-Bit Protection Register.....	21
1.1 3 Volt Advanced+ Boot Block Flash Memory Enhancements	5	3.4.1 Reading the Protection Register	21
1.2 Product Overview	6	3.4.2 Programming the Protection Register	21
2.0 PRODUCT DESCRIPTION.....	6	3.4.3 Locking the Protection Register	22
2.1 Package Pinouts	6	3.5 V _{PP} Program and Erase Voltages.....	22
2.2 Block Organization	10	3.5.1 Easy-12 V Operation for Fast Manufacturing Programming.....	22
2.2.1 Parameter Blocks	10	3.5.2 V _{PP} ≤ V _{PPLK} for Complete Protection	22
2.2.2 Main Blocks	10	3.5.3 V _{PP} Usage	22
3.0 PRINCIPLES OF OPERATION	11	3.6 Power Consumption	23
3.1 Bus Operation	11	3.6.1 Active Power (Program/Erase/Read)	23
3.1.1 Read.....	11	3.6.2 Automatic Power Savings (APS)	23
3.1.2 Output Disable.....	11	3.6.3 Standby Power	23
3.1.3 Standby	11	3.6.4 Deep Power-Down Mode.....	24
3.1.4 Reset.....	12	3.7 Power-Up/Down Operation.....	24
3.1.5 Write.....	12	3.7.1 RP# Connected to System Reset	24
3.2 Modes of Operation.....	12	3.7.2 V _{CC} , V _{PP} and RP# Transitions	24
3.2.1 Read Array	12	3.8 Power Supply Decoupling	24
3.2.2 Read Configuration.....	13	4.0 ABSOLUTE MAXIMUM RATINGS	25
3.2.3 Read Status Register	13	4.2 Operating Conditions.....	25
3.2.3.1 Clearing the Status Register	13	4.3 Capacitance	26
3.2.4 Read Query	13	4.4 DC Characteristics	26
3.2.5 Program Mode.....	14	4.5 AC Characteristics—Read Operations—Extended Temperature.....	30
3.2.5.1 Suspending and Resuming Program.....	14	4.6 AC Characteristics—Write Operations—Extended Temperature.....	32
3.2.6 Erase Mode.....	14	4.7 Erase and Program Timings	33
3.2.6.1 Suspending and Resuming Erase.....	15	4.8 Reset Operations	35
3.3 Flexible Block Locking.....	19	5.0 ORDERING INFORMATION.....	36
3.3.1 Locking Operation	19	6.0 ADDITIONAL INFORMATION	37
3.3.2 Locked State	19	APPENDIX A: WSM Current/Next States	38
3.3.3 Unlocked State	19	APPENDIX B: Program/Erase Flowcharts	40
3.3.4 Lock-Down State	19	APPENDIX C: Common Flash Interface Query Structure	46
3.3.5 Reading a Block's Lock Status	20		
3.3.6 Locking Operations during Erase Suspend.....	20		
3.3.7 Status Register Error Checking	20		

PRODUCT PREVIEW



APPENDIX D: Architecture Block Diagram	52	APPENDIX G: Device ID Table	57
APPENDIX E: Word-Wide Memory Map Diagrams	53	APPENDIX H: Protection Register Addressing	58
APPENDIX F: Byte-Wide Memory Map Diagrams	55		

REVISION HISTORY

Date of Revision	Version	Description
05/12/98	-001	Original version



1.0 INTRODUCTION

This document contains the specifications for the 3 Volt Advanced+ Boot Block flash memory family. These flash memories add features which can be used to enhance the security of systems: instant block locking and a protection register.

Throughout this document, the term “2.7 V” refers to the full voltage range 2.7 V–3.6 V (except where noted otherwise) and “V_{PP} = 12 V” refers to 12 V ±5%. Sections 1 and 2 provide an overview of the flash memory family including applications, pinouts, pin descriptions and memory organization. Section 3 describes the operation of these products. Finally, Section 4 contains the operating specifications.

1.1 3 Volt Advanced+ Boot Block Flash Memory Enhancements

The 3 Volt Advanced+ Boot Block flash memory features:

- Zero-latency, flexible block locking
- 128-bit Protection Register
- Simple system implementation for 12 V production programming with 2.7 V in-field programming
- Ultra-low power operation at 2.7 V
- Minimum 100,000 block erase cycles
- Common Flash Interface for software query of device specs and features

Table 1. 3 Volt Advanced+ Boot Block Feature Summary

Feature	8 M ⁽²⁾ 16 M 32 M ⁽¹⁾	8 M ⁽²⁾ 16 M 32 M	Reference
	V _{CC} Operating Voltage	2.7 V – 3.6 V	
V _{PP} Voltage	Provides complete write protection with optional 12V Fast Programming		Table 8
V _{CCQ} I/O Voltage	2.7 V– 3.6 V		Note 3
Bus Width	8-bit	16-bit	Table 2
Speed (ns)	90, 110 @ 2.7 V and 80, 100 @ 3.0 V		Table 11
Blocking (top or bottom)	8 x 8-Kbyte parameter 4-Mb: 7 x 64-Kbyte main 8-Mb: 15 x 64-Kbyte main 16-Mb: 31 x 64-Kbyte main 32-Mb: 63 x 64-Kbyte main	8 x 4-Kword parameter 4-Mb: 7 x 32-Kword main 8-Mb: 15 x 32-Kword main 16-Mb: 31 x 32-Kword main 32-Mb: 63 x 32-Kword main	Section 2.2 Appendix E and F
Operating Temperature	Extended: –40 °C to +85 °C		Table 8
Program/Erase Cycling	100,000 cycles		Table 8
Packages	40-Lead TSOP ⁽¹⁾ 48-Ball μBGA* CSP ⁽²⁾	48-Lead TSOP 48-Ball μBGA* CSP ⁽²⁾	Figures 1, 2, 3, and 4
Block Locking	Flexible locking of any block with zero latency		Section 3.3
Protection Register	64-bit unique device number, 64-bit user programmable		Section 3.4

NOTES:

1. 32-Mbit density not available in 40-lead TSOP.
2. 8-Mbit density not available in μBGA* CSP.
3. V_{CCQ} operation at 1.65 V — 2.5 V available upon request.

1.2 Product Overview

Intel provides secure low voltage memory solutions with the Advanced Boot Block family of products. A new block locking feature allows instant locking/unlocking of any block with zero-latency. A 128-bit protection register allows unique flash device identification.

Discrete supply pins provide single voltage read, program, and erase capability at 2.7 V while also allowing 12 V V_{PP} for faster production programming. Easy-12 V, a new feature designed to reduce external logic, simplifies board designs when combining 12 V production programming with 2.7 V in-field programming.

The 3 Volt Advanced+ Boot Block flash memory products are available in either x8 or x16 packages in the following densities: (see Section 6, *Ordering Information*)

- 8-Mbit (8,388,608 bit) flash memories organized as either 512 Kwords of 16 bits each or 1024 Kbytes or 8 bits each.
- 16-Mbit (16,777,216 bit) flash memories organized as either 1024 Kwords of 16 bits each or 2048 Kbytes of 8 bits each.
- 32-Mbit (33,554,432 bit) flash memories organized as either 2048 Kwords of 16 bits each or 4096 Kbytes of 8 bits each.

Eight 8-KB parameter blocks are located at either the top (denoted by -T suffix) or the bottom (-B suffix) of the address map in order to accommodate different microprocessor protocols for kernel code location. The remaining memory is grouped into 64-Kbyte main blocks.

All blocks can be locked or unlocked instantly to provide complete protection for code or data. (see Section 3.3 for details).

The Command User Interface (CUI) serves as the interface between the microprocessor or microcontroller and the internal operation of the flash memory. The internal Write State Machine (WSM) automatically executes the algorithms and timings necessary for program and erase operations, including verification, thereby unburdening the microprocessor or microcontroller.

The status register indicates the status of the WSM by signifying block erase or word program completion and status.

Program and erase automation allows program and erase operations to be executed using an industry-standard two-write command sequence to the CUI. Program operations are performed in word or byte increments. Erase operations erase all locations within a block simultaneously. Both program and erase operations can be suspended by the system software in order to read from any other block. In addition, data can be programmed to another block during an erase suspend.

The 3 Volt Advanced+ Boot Block flash memories offer two low power savings features: Automatic Power Savings (APS) and standby mode. The device automatically enters APS mode following the completion of a read cycle. Standby mode is initiated when the system deselects the device by driving CE# inactive. Combined, these two power savings features significantly reduce power consumption.

The device can be reset by lowering RP# to GND. This provides CPU-memory reset synchronization and additional protection against bus noise that may occur during system reset and power-up/down sequences (see Section 3.5 and 3.6).

Refer to the *DC Characteristics* Section 4.4 for complete current and voltage specifications. Refer to the *AC Characteristics* Sections 4.5 and 4.6, for read and write performance specifications. Program and erase times and shown in Section 4.7.

2.0 PRODUCT DESCRIPTION

This section provides device pin descriptions and package pinouts for the 3 Volt Advanced+ Boot Block flash memory family, which is available in 40-Lead TSOP (x8, Figure 1), 48-lead TSOP (x16, Figure 2) and 48-ball μ BGA packages (Figures 3 and 4).

2.1 Package Pinouts

In each diagram, upgrade pins from one density to the next are circled.

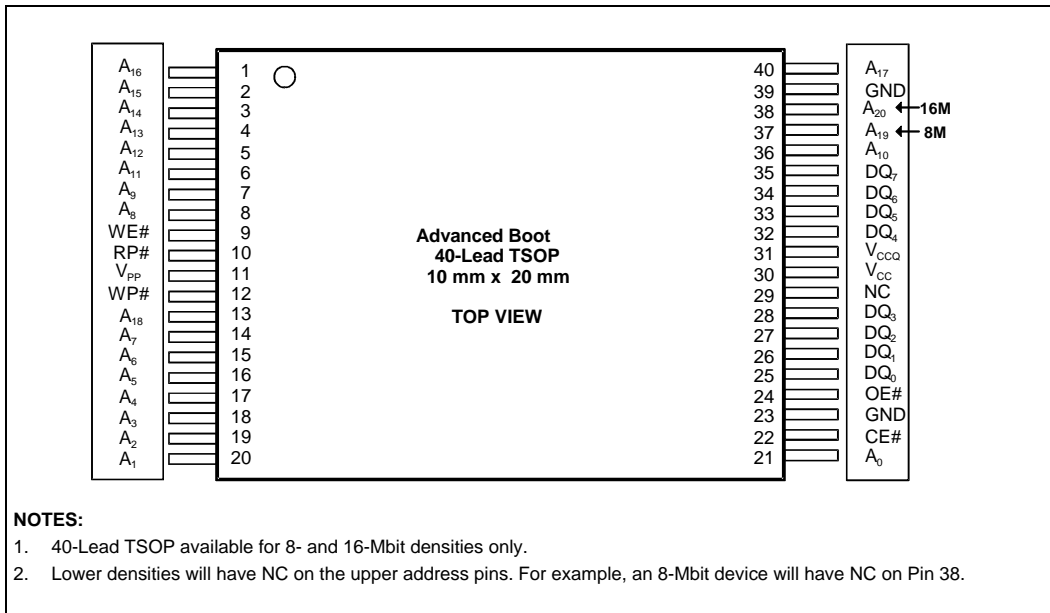

Figure 1. 40-Lead TSOP Package for x8 Configurations

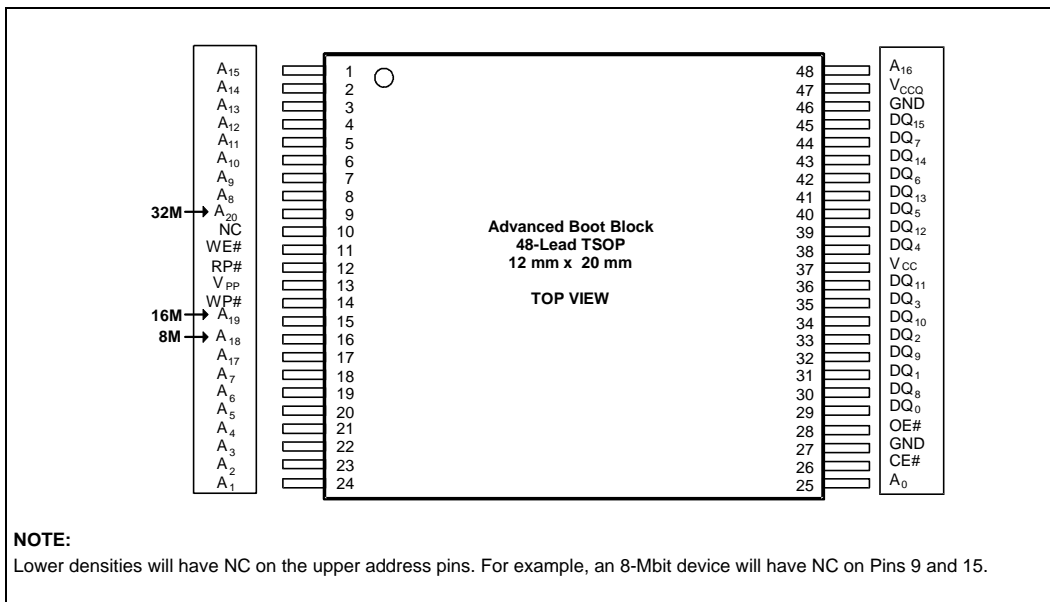

Figure 2. 48-Lead TSOP Package for x16 Configurations

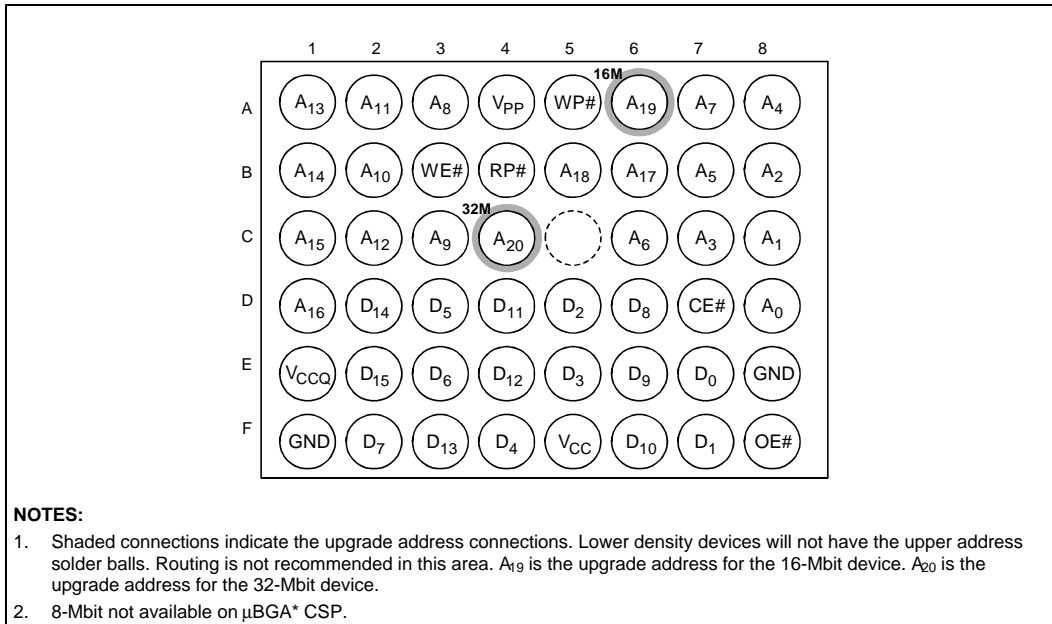

Figure 3. x16 48-Ball μBGA* Chip Size Package (Top View, Ball Down)

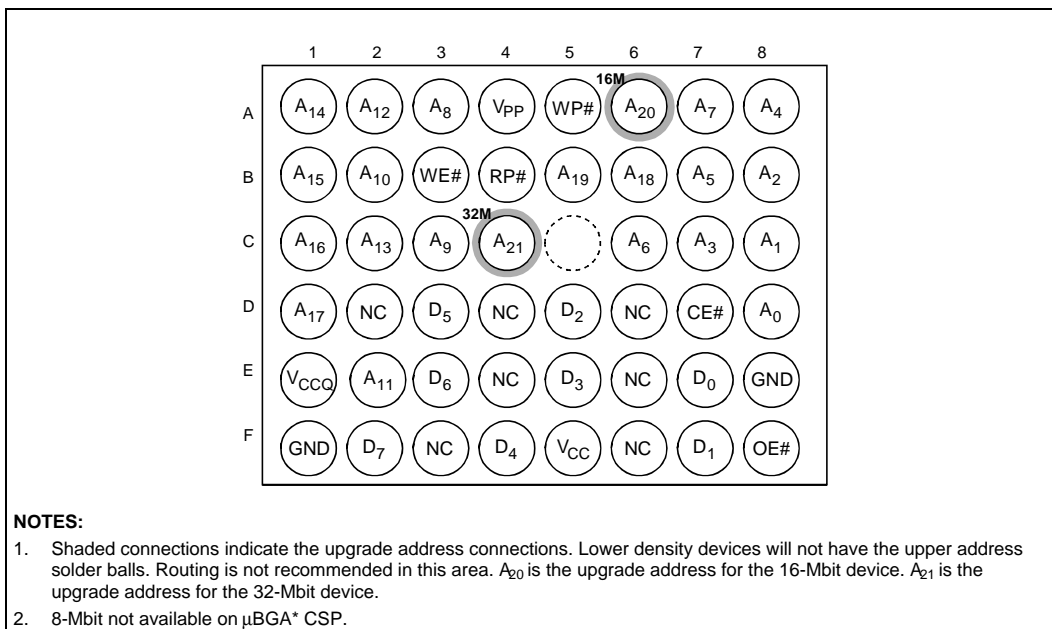

Figure 4. x8 48-Ball μBGA* Chip Size Package (Top View, Ball Down)

Table 2. 3 Volt Advanced+ Boot Block Pin Descriptions

Symbol	Type	Name and Function
A ₀ –A ₂₁	INPUT	ADDRESS INPUTS for memory addresses. Addresses are internally latched during a program or erase cycle. 8-Mbit x 8 A[0-19], 16-Mbit x 8 A[0-20], 32-Mbit x 8 A[0-21] 8-Mbit x 16 A[0-18], 16-Mbit x 16 A[0-19], 32-Mbit x 16 A[0-20]
DQ ₀ –DQ ₇	INPUT/OUTPUT	DATA INPUTS/OUTPUTS: Inputs array data on the second CE# and WE# cycle during a Program command. Inputs commands to the Command User Interface when CE# and WE# are active. Data is internally latched. Outputs array, configuration and status register data. The data pins float to tri-state when the chip is de-selected or the outputs are disabled.
DQ ₈ –DQ ₁₅	INPUT/OUTPUT	DATA INPUTS/OUTPUTS: Inputs array data on the second CE# and WE# cycle during a Program command. Data is internally latched. Outputs array and configuration data. The data pins float to tri-state when the chip is de-selected. Not included on x8 products.
CE#	INPUT	CHIP ENABLE: Activates the internal control logic, input buffers, decoders and sense amplifiers. CE# is active low. CE# high de-selects the memory device and reduces power consumption to standby levels.
OE#	INPUT	OUTPUT ENABLE: Enables the device's outputs through the data buffers during a read operation. OE# is active low.
WE#	INPUT	WRITE ENABLE: Controls writes to the Command Register and memory array. WE# is active low. Addresses and data are latched on the rising edge of the second WE# pulse.
RP#	INPUT	RESET/DEEP POWER-DOWN: Uses two voltage levels (V _{IL} , V _{IH}) to control reset/deep power-down mode. When RP# is at logic low, the device is in reset/deep power-down mode, which drives the outputs to High-Z, resets the Write State Machine, and minimizes current levels (I _{CCD}). When RP# is at logic high, the device is in standard operation. When RP# transitions from logic-low to logic-high, the device resets all blocks to locked and defaults to the read array mode.
WP#	INPUT	WRITE PROTECT: Controls the lock-down function of the flexible Locking feature When WP# is a logic low, the lock-down mechanism is enabled and blocks marked lock-down cannot be unlocked through software. When WP# is logic high, the lock-down mechanism is disabled and blocks previously locked-down are now locked and can be unlocked and locked through software. After WP# goes low, any blocks previously marked lock-down revert to that state. See Section 3.3 for details on block locking.
V _{CC}	SUPPLY	DEVICE POWER SUPPLY: [2.7 V–3.6 V] Supplies power for device operations.

Table 2. 3 Volt Advanced+ Boot Block Pin Descriptions (Continued)

Symbol	Type	Name and Function
V _{CCQ}	INPUT	I/O POWER SUPPLY: Supplies power for input/output buffers. [2.7 V–3.6 V] This input should be tied directly to V _{CC} . [1.65 V– 2.5 V] Lower I/O power supply voltage available upon request. Contact your Intel representative for more information.
V _{PP}	INPUT/ SUPPLY	PROGRAM/ERASE POWER SUPPLY: [1.65 V–3.6 V or 11.4 V–12.6 V] Operates as a input at logic levels to control complete device protection. Supplies power for accelerated program and erase operations in 12 V ± 5% range. This pin cannot be left floating. Lower V_{PP} ≤ V_{PPLK}, to protect all contents against Program and Erase commands. Set V_{PP} = V_{CC} for in-system read, program and erase operations. In this configuration, V _{PP} can drop as low as 1.65 V to allow for resistor or diode drop from the system supply. Note that if V _{PP} is driven by a logic signal, V _{IH} = 1.65. That is, V _{PP} must remain above 1.65V to perform in-system flash modifications. Raise V_{PP} to 12 V ± 5% for faster program and erase in a production environment. Applying 12 V ± 5% to V _{PP} can only be done for a maximum of 1000 cycles on the main blocks and 2500 cycles on the parameter blocks. V _{PP} may be connected to 12 V for a total of 80 hours maximum. See Section 3.4 for details on V _{PP} voltage configurations.
GND	SUPPLY	GROUND: For all internal circuitry. All ground inputs must be connected.
NC		NO CONNECT: Pin may be driven or left floating.

2.2 Block Organization

The 3 Volt Advanced+ Boot Block is an asymmetrically-blocked architecture that enables system integration of code and data within a single flash device. Each block can be erased independently of the others up to 100,000 times. For the address locations of each block, see the memory maps in Appendix E and F.

2.2.1 PARAMETER BLOCKS

The 3 Volt Advanced+ Boot Block flash memory architecture includes parameter blocks to facilitate storage of frequently updated small parameters (i.e., data that would normally be stored in an EEPROM). Each device contains eight parameter blocks of 8-Kbytes/4-Kwords (8,192 bytes/4,096 words).

2.2.2 MAIN BLOCKS

After the parameter blocks, the remainder of the array is divided into equal size (64-Kword/32-Kword; 65,536 bytes/32,768 words) main blocks for data or code storage. Each 8-Mbit, 16-Mbit, or 32-Mbit device contains 15, 31, or 63 main blocks, respectively.

3.0 PRINCIPLES OF OPERATION

The 3 Volt Advanced+ Boot Block flash memory family utilizes a CUI and automated algorithms to simplify program and erase operations. The CUI allows for 100% CMOS-level control inputs and fixed power supplies during erasure and programming.

The internal WSM completely automates program and erase operations while the CUI signals the start of an operation and the status register reports status. The CUI handles the WE# interface to the data and address latches, as well as system status requests during WSM operation.

3.1 Bus Operation

The 3 Volt Advanced+ Boot Block flash memory devices read, program and erase in-system via the local CPU or microcontroller. All bus cycles to or from the flash memory conform to standard microcontroller bus cycles. Four control pins dictate the data flow in and out of the flash component: CE#, OE#, WE# and RP#. These bus operations are summarized in Table 3.

3.1.1 READ

The flash memory has four read modes available: read array, read configuration, read status and read query. These modes are accessible independent of

the V_{PP} voltage. The appropriate read mode command must be issued to the CUI to enter the corresponding mode. Upon initial device power-up or after exit from reset, the device automatically defaults to read array mode.

CE# and OE# must be driven active to obtain data at the outputs. CE# is the device selection control; when active it enables the flash memory device. OE# is the data output control and it drives the selected memory data onto the I/O bus. For all read modes, WE# and RP# must be at V_{IH} . Figure 9 illustrates a read cycle.

3.1.2 OUTPUT DISABLE

With OE# at a logic-high level (V_{IH}), the device outputs are disabled. Output pins are placed in a high-impedance state.

3.1.3 STANDBY

Deselecting the device by bringing CE# to a logic-high level (V_{IH}) places the device in standby mode, which substantially reduces device power consumption without any latency for subsequent read accesses. In standby, outputs are placed in a high-impedance state independent of OE#. If deselected during program or erase operation, the device continues to consume active power until the program or erase operation is complete.

Table 3. Bus Operations⁽¹⁾

Mode	Note	RP#	CE#	OE#	WE#	DQ ₀₋₇	DQ ₈₋₁₅
Read (Array, Status, Configuration, or Query)	2-4	V_{IH}	V_{IL}	V_{IL}	V_{IH}	D_{OUT}	D_{OUT}
Output Disable	2	V_{IH}	V_{IL}	V_{IH}	V_{IH}	High Z	High Z
Standby	2	V_{IH}	V_{IH}	X	X	High Z	High Z
Reset	2,7	V_{IL}	X	X	X	High Z	High Z
Write	2,5-7	V_{IH}	V_{IL}	V_{IH}	V_{IL}	D_{IN}	D_{IN}

NOTES:

- 8-bit devices use only DQ[0:7], 16-bit devices use DQ[0:15]
- X must be V_{IL} , V_{IH} for control pins and addresses.
- See *DC Characteristics* for V_{PPLK} , V_{PP1} , V_{PP2} , V_{PP3} , voltages.
- Manufacturer and device codes may also be accessed in read configuration mode ($A_1-A_{20} = 0$). See Table 4.
- Refer to Table 5 for valid D_{IN} during a write operation.
- To program or erase the lockable blocks, hold WP# at V_{IH} .
- RP# must be at $GND \pm 0.2 V$ to meet the maximum deep power-down current specified.

3.1.4 RESET

From read mode, RP# at V_{IL} for time t_{PLPH} deselects the memory, places output drivers in a high-impedance state, and turns off all internal circuits. After return from reset, a time t_{PHQV} is required until the initial read access outputs are valid. A delay (t_{PHWL} or t_{PHEL}) is required after return from reset before a write can be initiated. After this wake-up interval, normal operation is restored. The CUI resets to read array mode, and the status register is set to 80H. This case is shown in Figure 11A.

If RP# is taken low for time t_{PLPH} during a program or erase operation, the operation will be aborted and the memory contents at the aborted location (for a program) or block (for an erase) are no longer valid, since the data may be partially erased or written. The abort process goes through the following sequence: When RP# goes low, the device shuts down the operation in progress, a process which takes time t_{PLRH} to complete. After this time t_{PLRH} , the part will either reset to read array mode (if RP# has gone high during t_{PLRH} , Figure 11B) or enter reset mode (if RP# is still logic low after t_{PLRH} , Figure 11C). In both cases, after returning from an aborted operation, the relevant time t_{PHQV} or t_{PHWL}/t_{PHEL} must be waited before a read or write operation is initiated, as discussed in the previous paragraph. However, in this case, these delays are referenced to the end of t_{PLRH} rather than when RP# goes high.

As with any automated device, it is important to assert RP# during system reset. When the system comes out of reset, processor expects to read from the flash memory. Automated flash memories provide status information when read during program or block erase operations. If a CPU reset occurs with no flash memory reset, proper CPU initialization may not occur because the flash memory may be providing status information instead of array data. Intel's flash memories allow proper CPU initialization following a system reset through the use of the RP# input. In this application, RP# is controlled by the same RESET# signal that resets the system CPU.

3.1.5 WRITE

A write takes place when both CE# and WE# are low and OE# is high. Commands are written to the Command User Interface (CUI) using standard microprocessor write timings to control flash operations. The CUI does not occupy an

addressable memory location. The address and data buses are latched on the rising edge of the second WE# or CE# pulse, whichever occurs first. Figure 10 illustrates a program and erase operation. The available commands are shown in Table 6, and Appendix A provides detailed information on moving between the different modes of operation using CUI commands.

There are two commands that modify array data: Program (40H) and Erase (20H). Writing either of these commands to the internal Command User Interface (CUI) initiates a sequence of internally-timed functions that culminate in the completion of the requested task (unless that operation is aborted by either RP# being driven to V_{IL} for t_{PLRH} or an appropriate suspend command).

3.2 Modes of Operation

The flash memory has four read modes and two write modes. The read modes are read array, read configuration, read status, and read query. The write modes are program and block erase. Three additional modes (erase suspend to program, erase suspend to read and program suspend to read) are available only during suspended operations. These modes are reached using the commands summarized in Tables 5 and 6. A comprehensive chart showing the state transitions is in Appendix A.

3.2.1 READ ARRAY

When RP# transitions from V_{IL} (reset) to V_{IH} , the device defaults to read array mode and will respond to the read control inputs (CE#, address inputs, and OE#) without any additional CUI commands.

When the device is in read array mode, four control signals control data output:

- WE# must be logic high (V_{IH})
- CE# must be logic low (V_{IL})
- OE# must be logic low (V_{IL})
- RP# must be logic high (V_{IH})

In addition, the address of the desired location must be applied to the address pins. If the device is not in read array mode, as would be the case after a program or erase operation, the Read Array command (FFH) must be written to the CUI before array reads can take place.

3.2.2 READ CONFIGURATION

The Read Configuration mode outputs the manufacturer/device identifier. The device is switched to this mode by writing the Read Configuration command (90H). Once in this mode, read cycles from addresses shown in Table 4 retrieve the specified information. To return to read array mode, write the Read Array command (FFH).

The Read Configuration mode outputs three types of information: the manufacturer/device identifier, the block locking status, and the protection register. The device is switched to this mode by writing the Read Configuration command (90H). Once in this mode, read cycles from addresses shown in Table 4 retrieve the specified information. To return to read array mode, write the Read Array command (FFH).

Table 4. Read Configuration Table

Item	Address	Data
Manufacturer Code (x16)	00000	0089
Manufacturer Code (x8)	00000	89
Device ID (See Appendix G)	00001	ID
Block Lock Configuration ²	XX002 ⁽¹⁾	LOCK
• Block Is Unlocked		DQ ₀ = 0
• Block Is Locked		DQ ₀ = 1
• Block Is Locked-Down		DQ ₁ = 1
Protection Register Lock ³	80	PR-LK
Protection Register (x16)	81-88	PR
Protection Register (x8)	(App. H)	PR

NOTES:

1. "XX" specifies the block address of lock configuration being read.
2. See Section 3.3.4 for valid lock status outputs.
3. See Section 3.4 for protection register information.
4. Other locations within the configuration address space are reserved by Intel for future use.

3.2.3 READ STATUS REGISTER

The status register indicates the status of device operations, and the success/failure of that operation. The Read Status Register (70H)

command causes subsequent reads to output data from the status register until another command is issued. To return to reading from the array, issue a Read Array (FFH) command.

The status register bits are output on DQ₀–DQ₇. The upper byte, DQ₈–DQ₁₅, outputs 00H during a Read Status Register command.

The contents of the status register are latched on the falling edge of OE# or CE#, whichever occurs last. This prevents possible bus errors which might occur if status register contents change while being read. CE# or OE# must be toggled with each subsequent status read, or the status register will not indicate completion of a program or erase operation.

When the WSM is active, SR.7 will indicate the status of the WSM; the remaining bits in the status register indicate whether the WSM was successful in performing the desired operation (see Table 7).

3.2.3.1 Clearing the Status Register

The WSM sets status bits 1 through 7 to "1," and clears bits 2, 6 and 7 to "0," but cannot clear status bits 1 or 3 through 5 to "0." Because bits 1, 3, 4 and 5 indicate various error conditions, these bits can only be cleared through the use of the Clear Status Register (50H) command. By allowing the system software to control the resetting of these bits, several operations may be performed (such as cumulatively programming several addresses or erasing multiple blocks in sequence) before reading the status register to determine if an error occurred during that series. Clear the Status Register before beginning another command or sequence. Note that the Read Array command must be issued before data can be read from the memory array. Resetting the device also clears the status register.

3.2.4 READ QUERY

The Read Query mode outputs Common Flash Interface (CFI) data when the device is read. This can be accessed by writing the Read Query Command (98H). The CFI data structure contains information such as block size, density, command set and electrical specifications. Once in this mode, read cycles from addresses shown in Appendix C retrieve the specified information. To return to read array mode, write the Read Array command (FFH).

3.2.5 PROGRAM MODE

Programming is executed using a two-write sequence. The Program Setup command (40H) is written to the CUI followed by a second write which specifies the address and data to be programmed. The WSM will execute a sequence of internally timed events to program desired bits of the addressed location, then verify the bits are sufficiently programmed. Programming the memory results in specific bits within an address location being changed to a "0." If the user attempts to program "1"s, the memory cell contents do not change and no error occurs.

The status register indicates programming status: while the program sequence executes, status bit 7 is "0." The status register can be polled by toggling either CE# or OE#. While programming, the only valid commands are Read Status Register, Program Suspend, and Program Resume.

When programming is complete, the Program Status bits should be checked. If the programming operation was unsuccessful, bit SR.4 of the status register is set to indicate a program failure. If SR.3 is set then V_{PP} was not within acceptable limits, and the WSM did not execute the program command. If SR.1 is set, a program operation was attempted on a locked block and the operation was aborted.

The status register should be cleared before attempting the next operation. Any CUI instruction can follow after programming is completed; however, to prevent inadvertent status register reads, be sure to reset the CUI to read array mode.

3.2.5.1 Suspending and Resuming Program

The Program Suspend command halts an in-progress program operation so that data can be read from other locations of memory. Once the programming process starts, writing the Program Suspend command to the CUI requests that the WSM suspend the program sequence (at predetermined points in the program algorithm). The device continues to output status register data after the Program Suspend command is written. Polling status register bits SR.7 and SR.2 will determine when the program operation has been suspended (both will be set to "1"). t_{WHRH1}/t_{EHRH1} specify the program suspend latency.

A Read Array command can now be written to the CUI to read data from blocks other than that which is suspended. The only other valid commands, while program is suspended, are Read Status Register, Read Configuration, Read Query, and Program Resume. After the Program Resume command is written to the flash memory, the WSM will continue with the programming process and status register bits SR.2 and SR.7 will automatically be cleared. The device automatically outputs status register data when read (see Figure 13 in Appendix B, *Program Suspend/Resume Flowchart*) after the Program Resume command is written. V_{PP} must remain at the same V_{PP} level used for program while in program suspend mode. RP# must also remain at V_{IH} .

3.2.6 ERASE MODE

To erase a block, write the Erase Set-up and Erase Confirm commands to the CUI, along with an address identifying the block to be erased. This address is latched internally when the Erase Confirm command is issued. Block erasure results in all bits within the block being set to "1." Only one block can be erased at a time. The WSM will execute a sequence of internally timed events to program all bits within the block to "0," erase all bits within the block to "1," then verify that all bits within the block are sufficiently erased. While the erase executes, status bit 7 is a "0."

When the status register indicates that erasure is complete, check the erase status bit to verify that the erase operation was successful. If the Erase operation was unsuccessful, SR.5 of the status register will be set to a "1," indicating an erase failure. If V_{PP} was not within acceptable limits after the Erase Confirm command was issued, the WSM will not execute the erase sequence; instead, SR.5 of the status register is set to indicate an erase error, and SR.3 is set to a "1" to identify that V_{PP} supply voltage was not within acceptable limits.

After an erase operation, clear the status register (50H) before attempting the next operation. Any CUI instruction can follow after erasure is completed; however, to prevent inadvertent status register reads, it is advisable to place the flash in read array mode after the erase is complete.

3.2.6.1 Suspending and Resuming Erase

Since an erase operation requires on the order of seconds to complete, an Erase Suspend command is provided to allow erase-sequence interruption in order to read data from or program data to another block in memory. Once the erase sequence is started, writing the Erase Suspend command to the CUI suspends the erase sequence at a predetermined point in the erase algorithm. The status register will indicate if/when the erase operation has been suspended. Erase suspend latency is specified by t_{WHRH2}/t_{EHRH2} .

A Read Array/Program command can now be written to the CUI to read/program data from/to blocks other than that which is suspended. This nested Program command can subsequently be suspended to read yet another location. The only valid commands while erase is suspended are Read Status Register, Read Configuration, Read Query, Program Setup, Program Resume, Erase Resume, Lock Block, Unlock Block and Lock-Down Block. During erase suspend mode, the chip can be placed in a pseudo-standby mode by taking CE# to V_{IH} . This reduces active current consumption.

Erase Resume continues the erase sequence when $CE\# = V_{IL}$. As with the end of a standard erase operation, the status register must be read and cleared before the next instruction is issued.

Table 5. Command Bus Definitions

Command	Notes	First Bus Cycle			Second Bus Cycle		
		Oper	Addr	Data	Oper	Addr	Data
Read Array	4	Write	X	FFH			
Read Configuration	2, 4	Write	X	90H	Read	IA	ID
Read Query	2, 4	Write	X	98H	Read	QA	QD
Read Status Register	4	Write	X	70H	Read	X	SRD
Clear Status Register	4	Write	X	50H			
Program	3,4	Write	X	40H/10H	Write	PA	PD
Block Erase/Confirm	4	Write	X	20H	Write	BA	D0H
Program/Erase Suspend	4	Write	X	B0H			
Program/Erase Resume	4	Write	X	D0H			
Lock Block	4	Write	X	60H	Write	BA	01H
Unlock Block	4	Write	X	60H	Write	BA	D0H
Lock-Down Block	4	Write	X	60H	Write	BA	2FH
Protection Program	4	Write	X	C0H	Write	PA	PD

X = Don't Care PA = Prog Addr BA = Block Addr IA = Identifier Addr. QA = Query Addr.
 SRD = Status Reg. Data PD = Prog Data ID = Identifier Data QD = Query Data

NOTES:

1. Bus operations are defined in Table 3.
2. Following the Read Configuration or Read Query commands, read operations output device configuration or CFI query information, respectively. See Section 3.2.2 and 3.2.4.
3. Either 40H or 10H command is valid, but the Intel standard is 40H.
4. When writing commands, the upper data bus [DQ₈-DQ₁₅] should be either V_{IL} or V_{IH} , to minimize current draw.

Table 6. Command Codes and Descriptions

Code	Device Mode	Description
FF	Read Array	Places device in read array mode, such that array data will be output on the data pins.
40	Program Set-Up	This is a two-cycle command. The first cycle prepares the CUI for a program operation. The second cycle latches addresses and data information and initiates the WSM to execute the Program algorithm. The flash outputs status register data when CE# or OE# is toggled. A Read Array command is required after programming to read array data. See Section 3.2.5.
20	Erase Set-Up	Prepares the CUI for the Erase Confirm command. If the next command is not an Erase Confirm command, then the CUI will (a) set both SR.4 and SR.5 of the status register to a "1," (b) place the device into the read status register mode, and (c) wait for another command. See Section 3.2.6.
D0	Erase Confirm	If the previous command was an Erase Set-Up command, then the CUI will close the address and data latches, and begin erasing the block indicated on the address pins. During program/erase, the device will respond only to the Read Status Register, Program Suspend and Erase Suspend commands and will output status register data when CE# or OE# is toggled.
	Program/Erase Resume	If a program or erase operation was previously suspended, this command will resume that operation.
	Unlock Block	If the previous command was Configuration Set-Up, the CUI will latch the address and unlock the block indicated on the address pins. If the block had been previously set to Lock-Down, this operation will have no effect. (Sect. 3.3)
B0	Program Suspend	Issuing this command will begin to suspend the currently executing program/erase operation. The status register will indicate when the operation has been successfully suspended by setting either the program suspend (SR.2) or erase suspend (SR.6) and the WSM Status bit (SR.7) to a "1" (ready). The WSM will continue to idle in the SUSPEND state, regardless of the state of all input control pins except RP#, which will immediately shut down the WSM and the remainder of the chip if RP# is driven to V_{IL} . See Sections 3.2.5.1 and 3.2.6.1.
	Erase Suspend	
70	Read Status Register	This command places the device into read status register mode. Reading the device will output the contents of the status register, regardless of the address presented to the device. The device automatically enters this mode after a program or erase operation has been initiated. See Section 3.2.3.
50	Clear Status Register	The WSM can set the Block Lock Status (SR.1), V_{PP} Status (SR.3), Program Status (SR.4), and Erase Status (SR.5) bits in the status register to "1," but it cannot clear them to "0." Issuing this command clears those bits to "0."
90	Read Configuration	Puts the device into the Read Configuration mode, so that reading the device will output the manufacturer/device codes or block lock status. Section 3.2.2.
60	Configuration Set-Up	Prepares the CUI for changes to the device configuration, such as block locking changes. If the next command is not Block Unlock, Block Lock, or Block Lock-Down, then the CUI will set both the Program and Erase Status register bits to indicate a command sequence error. See Section 3.3.
01	Lock-Block	If the previous command was Configuration Set-Up, the CUI will latch the address and lock the block indicated on the address pins. (Section 3.3)

Table 6. Command Codes and Descriptions (Continued)

Code	Device Mode	Description
2F	Lock-Down	If the previous command was a Configuration Set-Up command, the CUI will latch the address and lock-down the block indicated on the address pins. (Section 3.3)
98	Read Query	Puts the device into the Read Query mode, so that reading the device will output Common Flash Interface information. See Section 3.2.4 and Appendix C.
C0	Protection Program Setup	This is a two-cycle command. The first cycle prepares the CUI for an program operation to the Protection Register. The second cycle latches addresses and data information and initiates the WSM to execute the Protection Program algorithm to the Protection Register. The flash outputs status register data when CE# or OE# is toggled. A Read Array command is required after programming to read array data. See Section 3.4.
10	Alt. Prog Set-Up	Operates the same as Program Set-up command. (See 40H/Program Set-Up)
00	Invalid/Reserved	Unassigned commands that should not be used. Intel reserves the right to redefine these codes for future functions.

NOTE:

See Appendix A for mode transition information.

Table 7. Status Register Bit Definition

WSMS	ESS	ES	PS	VPPS	PSS	BLS	R
7	6	5	4	3	2	1	0
NOTES:							
SR.7 WRITE STATE MACHINE STATUS 1 = Ready (WSMS) 0 = Busy				Check Write State Machine bit first to determine Word Program or Block Erase completion, before checking Program or Erase Status bits.			
SR.6 = ERASE-SUSPEND STATUS (ESS) 1 = Erase Suspended 0 = Erase In Progress/Completed				When Erase Suspend is issued, WSM halts execution and sets both WSMS and ESS bits to "1." ESS bit remains set to "1" until an Erase Resume command is issued.			
SR.5 = ERASE STATUS (ES) 1 = Error In Block Erase 0 = Successful Block Erase				When this bit is set to "1," WSM has applied the max. number of erase pulses to the block and is still unable to verify successful block erasure.			
SR.4 = PROGRAM STATUS (PS) 1 = Error in Programming 0 = Successful Programming				When this bit is set to "1," WSM has attempted but failed to program a word/byte.			
SR.3 = V _{PP} STATUS (VPPS) 1 = V _{PP} Low Detect, Operation Abort 0 = V _{PP} OK				The V _{PP} status bit does not provide continuous indication of V _{PP} level. The WSM interrogates V _{PP} level only after the Program or Erase command sequences have been entered, and informs the system if V _{PP} has not been switched on. The V _{PP} is also checked before the operation is verified by the WSM. The V _{PP} status bit is not guaranteed to report accurate feedback between V _{PP} and V _{PP1Min} .			
SR.2 = PROGRAM SUSPEND STATUS (PSS) 1 = Program Suspended 0 = Program in Progress/Completed				When Program Suspend is issued, WSM halts execution and sets both WSMS and PSS bits to "1." PSS bit remains set to "1" until a Program Resume command is issued.			
SR.1 = BLOCK LOCK STATUS 1 = Prog/Erase attempted on a locked block; Operation aborted. 0 = No operation to locked blocks				If a program or erase operation is attempted to one of the locked blocks, this bit is set by the WSM. The operation specified is aborted and the device is returned to read status mode.			
SR.0 = RESERVED FOR FUTURE ENHANCEMENTS (R)				This bit is reserved for future use and should be masked out when polling the status register.			

3.3 Flexible Block Locking

The Intel® 3 Volt Advanced+ Boot Block products offer an instant, individual block locking scheme that allows any block to be locked or unlocked with no latency, enabling instant code and data protection.

This locking scheme offers two levels of protection. The first level allows software-only control of block locking (useful for data blocks that change frequently), while the second level requires hardware interaction before locking can be changed (useful for code blocks that change infrequently).

The following sections will discuss the operation of the locking system. The term “state [XYZ]” will be used to specify locking states; e.g., “state [001],” where X = value of WP#, Y = bit DQ₁ of the Block Lock status register, and Z = bit DQ₀ of the Block Lock status register. Table 9 defines all of these possible locking states.

3.3.1 LOCKING OPERATION

The following concisely summarizes the locking functionality.

- All blocks power-up locked, then can be unlocked or locked with the Unlock and Lock commands.
- The Lock-Down command locks a block and prevents it from being unlocked when WP# = 0.
 - When WP# = 1, Lock-Down is overridden and commands can unlock/lock locked-down blocks.
 - When WP# returns to 0, locked-down blocks return to Lock-Down.
 - Lock-Down is cleared only when the device is reset or powered-down.

The locking status of each block can set to Locked, Unlocked, and Lock-Down, each of which will be described in the following sections. A comprehensive state table for the locking functions is shown in Table 9, and a flowchart for locking operations is shown in Figure 16.

3.3.2 LOCKED STATE

The default status of all blocks upon power-up or reset is locked (states [001] or [101]). Locked blocks are fully protected from alteration. Any program or erase operations attempted on a locked block will return an error on bit SR.1 of the status register. The status of a locked block can be changed to Unlocked or Lock-Down using the appropriate software commands. An Unlocked block can be locked by writing the Lock command sequence, 60H followed by 01H.

3.3.3 UNLOCKED STATE

Unlocked blocks (states [000], [100], [110]) can be programmed or erased. All unlocked blocks return to the Locked state when the device is reset or powered down. The status of an unlocked block can be changed to Locked or Locked-Down using the appropriate software commands. A Locked block can be unlocked by writing the Unlock command sequence, 60H followed by D0H.

3.3.4 LOCK-DOWN STATE

Blocks that are Locked-Down (state [011]) are protected from program and erase operations (just like Locked blocks), but their protection status cannot be changed using software commands alone. A Locked or Unlocked block can be Locked-down by writing the Lock-Down command sequence, 60H followed by 2FH. Locked-Down blocks revert to the Locked state when the device is reset or powered down.

The Lock-Down function is dependent on the WP# input pin. When WP# = 0, blocks in Lock-Down [011] are protected from program, erase, and lock status changes. When WP# = 1, the Lock-Down function is disabled ([111]) and locked-down blocks can be individually unlocked by software command to the [110] state, where they can be erased and programmed. These blocks can then be relocked [111] and unlocked [110] as desired while WP# remains high. When WP# goes low, blocks that were previously locked-down return to the Lock-Down state [011] regardless of any changes made while WP# was high. Device reset or power-down resets all blocks, including those in Lock-Down, to Locked state.

3.3.5 READING A BLOCK'S LOCK STATUS

The lock status of every block can be read in the Configuration Read mode of the device. To enter this mode, write 90H to the device. Subsequent reads at Block Address + 00002 will output the lock status of that block. The lock status is represented by the lowest two output pins, DQ₀ and DQ₁. DQ₀ indicates the Block Lock/Unlock status and is set by the Lock command and cleared by the Unlock command. It is also automatically set when entering Lock-Down. DQ₁ indicates Lock-Down status and is set by the Lock-Down command. It cannot be cleared by software, only by device reset or power-down.

Table 8. Block Lock Status

Item	Address	Data
Block Lock Configuration	XX002	LOCK
• Block Is Unlocked		DQ ₀ = 0
• Block Is Locked		DQ ₀ = 1
• Block Is Locked-Down		DQ ₁ = 1

3.3.6 LOCKING OPERATIONS DURING ERASE SUSPEND

Changes to block lock status can be performed during an erase suspend by using the standard locking command sequences to unlock, lock, or lock-down a block. This is useful in the case when another block needs to be updated while an erase operation is in progress.

To change block locking during an erase operation, first write the erase suspend command (B0H), then check the status register until it indicates that the erase operation has been suspended. Next write the desired lock command sequence to a block and

the lock status will be changed. After completing any desired lock, read, or program operations, resume the erase operation with the Erase Resume command (D0H).

If a block is locked or locked-down during a suspended erase of the same block, the locking status bits will be changed immediately, but when the erase is resumed, the erase operation will complete.

Locking operations cannot be performed during a program suspend. Refer to Appendix A for detailed information on which commands are valid during erase suspend.

3.3.7 STATUS REGISTER ERROR CHECKING

Using nested locking or program command sequences during erase suspend can introduce ambiguity into status register results.

Since locking changes are performed using a two cycle command sequence, e.g., 60H followed by 01H to lock a block, following the Configuration Setup command (60H) with an invalid command will produce a lock command error (SR.4 and SR.5 will be set to 1) in the status register. If a lock command error occurs during an erase suspend, SR.4 and SR.5 will be set to 1, and will remain at 1 after the erase is resumed. When erase is complete, any possible error during the erase cannot be detected via the status register because of the previous locking command error.

A similar situation happens if an error occurs during a program operation error nested within an erase suspend.

Table 9. Block Locking State Transitions

Current State			Erase/Prog Allowed?	Lock Command Input Result [Next State]		
WP#	DQ ₁	DQ ₀		Lock	Unlock	Lock-Down
0	0	0	Yes	Goes To [001]	No Change	Goes To [011]
0	0	1	No	No Change	Goes To [000]	Goes To [011]
0	1	1	No	No Change	No Change	No Change
1	0	0	Yes	Goes To [101]	No Change	Goes To [111]
1	0	1	No	No Change	Goes To [100]	Goes To [111]
1	1	0	Yes	Goes To [111]	No Change	Goes To [111]
1	1	1	No	No Change	Goes To [110]	No Change

NOTES:

1. In this table, the notation [XYZ] denotes the locking state of a block, where X = WP#, Y = DQ₁, and Z = DQ₀. The current locking state of a block is defined by the state of WP# and the two bits of the block lock status (DQ₀, DQ₁). DQ₀ indicates if a block is locked (1) or unlocked (0). DQ₁ indicates if a block has been locked-down (1) or not (0).
2. At power-up or device reset, all blocks default to Locked state [001] (if WP# = 0). Holding WP# = 0 is the recommended default.
3. The "Erase/Program Allowed?" column shows whether erase and program operations are enabled (Yes) or disabled (No) in that block's current locking state.
4. The "Lock Command Input Result [Next State]" column shows the result of writing the three locking commands (Lock, Unlock, Lock-Down) in the current locking state. For example, "Goes To [001]" would mean that writing the command to a block in the current locking state would change it to [001].

3.4 128-Bit Protection Register

The Advanced+ Boot Block architecture includes a 128-bit protection register that can be used to increase the security of a system design. For example, the number contained in the protection register can be used to "mate" the flash component with other system components such as the CPU or ASIC, preventing device substitution. Additional application information can be found in Intel application note *AP-657 Designing with the Advanced+ Boot Block Flash Memory Architecture*.

The 128-bits of the protection register are divided into two 64-bit segments. One of the segments is programmed at the Intel factory with a unique 64-bit number, which is unchangeable. The other segment is left blank for customer designs to program as desired. Once the customer segment is programmed, it can be locked to prevent reprogramming.

3.4.1 READING THE PROTECTION REGISTER

The protection register is read in the configuration read mode. The device is switched to this mode by writing the Read Configuration command (90H). Once in this mode, read cycles from addresses shown in Appendix H retrieve the specified information. To return to read array mode, write the Read Array command (FFH).

3.4.2 PROGRAMMING THE PROTECTION REGISTER

The protection register bits are programmed using the two-cycle Protection Program command. The 64-bit number is programmed 16 bits at a time for word-wide parts and eight bits at a time for byte-wide parts. First write the Protection Program Setup command, C0H. The next write to the device will latch in address and data and program the specified location. The allowable addresses are shown in Appendix H. See Figure 17 for the *Protection Register Programming Flowchart*.

3 VOLT ADVANCED+ BOOT BLOCK



Any attempt to address Protection Program commands outside the defined protection register address space will result in a Status Register error (Program Error bit SR.4 will be set to 1). Attempting to program or to a previously locked protection register segment will result in a status register error (program error bit SR.4 and lock error bit SR.1 will be set to 1).

3.4.3 LOCKING THE PROTECTION REGISTER

The user-programmable segment of the protection register is lockable by programming Bit 1 of the PR-LOCK location to 0. Bit 0 of this location is programmed to 0 at the Intel factory to protect the unique device number. This bit is set using the Protection Program command to program "FFFD" to the PR-LOCK location. After these bits have been programmed, no further changes can be made to the values stored in the protection register. Protection Program commands to a locked section will result in a status register error (Program Error bit SR.4 and Lock Error bit SR.1 will be set to 1). Protection register lockout state is not reversible.

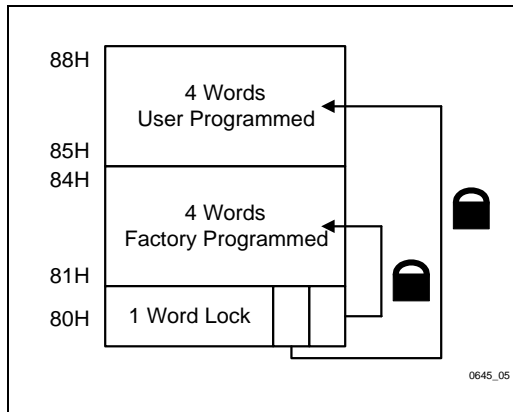

Figure 5. Protection Register Memory Map

3.5 V_{PP} Program and Erase Voltages

Intel's 3 Volt Advanced+ Boot Block products provide in-system writes plus a V_{PP} pin for 12 V production programming and complete write protection.

3.5.1 EASY-12 V OPERATION FOR FAST MANUFACTURING PROGRAMMING

Intel's 3 Volt Advanced+ Boot Block products provide in-system programming and erase in the 2.7 V–3.6 V range. For fast production programming, 3 Volt Advanced+ Boot Block includes a low-cost, backward-compatible 12 V programming feature.

When V_{PP} is between 1.65 V and 3.6 V, all program and erase current is drawn through the V_{CC} pin. Note that if V_{PP} is driven by a logic signal, V_{IH} = 1.65 V. That is, V_{PP} must remain above 1.65 V to perform in-system flash modifications. When V_{PP} is connected to a 12 V power supply, the device draws program and erase current directly from the V_{PP} pin. This eliminates the need for an external switching transistor to control the voltage V_{PP}. Figure 6 shows examples of how the flash power supplies can be configured for various usage models.

The 12 V V_{PP} mode enhances programming performance during the short period of time typically found in manufacturing processes; however, it is not intended for extended use. 12 V may be applied to V_{PP} during program and erase operations for a maximum of 1000 cycles on the main blocks and 2500 cycles on the parameter blocks. V_{PP} may be connected to 12 V for a total of 80 hours maximum. Stressing the device beyond these limits may cause permanent damage.

3.5.2 V_{PP} ≤ V_{PPLK} FOR COMPLETE PROTECTION

In addition to the flexible block locking, the V_{PP} programming voltage can be held low for absolute hardware write protection of all blocks in the flash device. When V_{PP} is below V_{PPLK}, any program or erase operation will result in an error, prompting the corresponding status register bit (SR.3) to be set.

3.5.3 V_{PP} USAGE

The V_{PP} pin is used for two functions: Absolute data protection and fast production programming.

When V_{PP} ≤ V_{PPLK}, then all program or erase operations to the device are inhibited, providing absolute data protection.

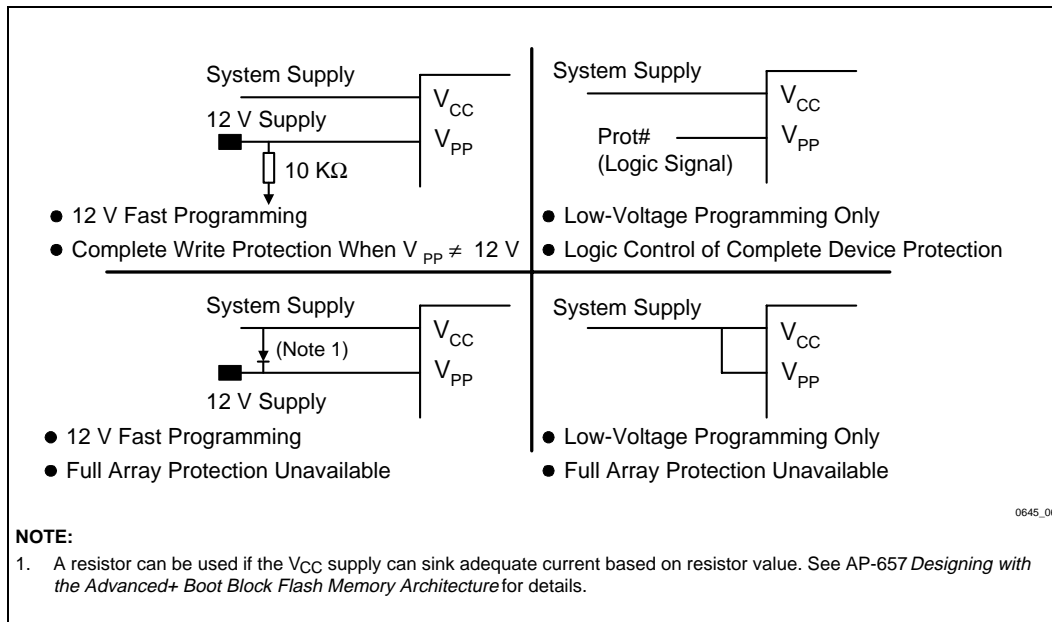

Figure 6. Example Power Supply Configurations

When V_{PP} is raised to 12 V, such as in a manufacturing situations, the device directly applies the high voltage to achieve faster program and erase.

Designing for in-system writes to the flash memory requires special consideration of power supply traces by the printed circuit board designer. Adequate power supply traces, and decoupling capacitors placed adjacent to the component, will decrease spikes and overshoots.

3.6 Power Consumption

Intel's flash devices have a tiered approach to power savings that can significantly reduce overall system power consumption. The Automatic Power Savings (APS) feature reduces power consumption when the device is selected but idle. If the $CE\#$ is deasserted, the flash enters its standby mode, where current consumption is even lower. The combination of these features can minimize memory power consumption, and therefore, overall system power consumption.

3.6.1 ACTIVE POWER (Program/Erase/Read)

With $CE\#$ at a logic-low level and $RP\#$ at a logic-high level, the device is in the active mode. Refer to the DC Characteristic tables for I_{CC} current values. Active power is the largest contributor to overall system power consumption. Minimizing the active current could have a profound effect on system power consumption, especially for battery-operated devices.

3.6.2 AUTOMATIC POWER SAVINGS (APS)

Automatic Power Savings provides low-power operation during read mode. After data is read from the memory array and the address lines are quiescent, APS circuitry places the device in a mode where typical current is comparable to I_{CCS} . The flash stays in this static state with outputs valid until a new location is read.

3.6.3 STANDBY POWER

With $CE\#$ at a logic-high level (V_{IH}) and device in read mode, the flash memory is in standby mode, which disables much of the device's circuitry and

3 VOLT ADVANCED+ BOOT BLOCK

substantially reduces power consumption. Outputs are placed in a high-impedance state independent of the status of the OE# signal. If CE# transitions to a logic-high level during erase or program operations, the device will continue to perform the operation and consume corresponding active power until the operation is completed.

System engineers should analyze the breakdown of standby time versus active time and quantify the respective power consumption in each mode for their specific application. This will provide a more accurate measure of application-specific power and energy requirements.

3.6.4 DEEP POWER-DOWN MODE

The deep power-down mode is activated when $RP\# = V_{IL}$ ($GND \pm 0.2 V$). During read modes, $RP\#$ going low de-selects the memory and places the outputs in a high impedance state. Recovery from deep power-down requires a minimum time of t_{PHQV} for read operations and t_{PHWL}/t_{PHEL} for write operations.

During program or erase modes, $RP\#$ transitioning low will abort the in-progress operation. The memory contents of the address being programmed or the block being erased are no longer valid as the data integrity has been compromised by the abort. During deep power-down, all internal circuits are switched to a low power savings mode ($RP\#$ transitioning to V_{IL} or turning off power to the device clears the status register).

3.7 Power-Up/Down Operation

The device is protected against accidental block erasure or programming during power transitions. Power supply sequencing is not required, since the device is indifferent as to which power supply, V_{PP} or V_{CC} , powers-up first.

3.7.1 $RP\#$ CONNECTED TO SYSTEM RESET

The use of $RP\#$ during system reset is important with automated program/erase devices since the system expects to read from the flash memory when it comes out of reset. If a CPU reset occurs without a flash memory reset, proper CPU initialization will not occur because the flash memory may be providing status information instead of array data. Intel recommends connecting $RP\#$ to the system CPU RESET# signal to allow

proper CPU/flash initialization following system reset.

System designers must guard against spurious writes when V_{CC} voltages are above V_{LKO} . Since both $WE\#$ and $CE\#$ must be low for a command write, driving either signal to V_{IH} will inhibit writes to the device. The CUI architecture provides additional protection since alteration of memory contents can only occur after successful completion of the two-step command sequences. The device is also disabled until $RP\#$ is brought to V_{IH} , regardless of the state of its control inputs. By holding the device in reset ($RP\#$ connected to system PowerGood) during power-up/down, invalid bus conditions during power-up can be masked, providing yet another level of memory protection.

3.7.2 V_{CC} , V_{PP} AND $RP\#$ TRANSITIONS

The CUI latches commands as issued by system software and is not altered by V_{PP} or $CE\#$ transitions or WSM actions. Its default state upon power-up, after exit from reset mode or after V_{CC} transitions above V_{LKO} (Lockout voltage), is read array mode.

After any program or block erase operation is complete (even after V_{PP} transitions down to V_{PPLK}), the CUI must be reset to read array mode via the Read Array command if access to the flash memory array is desired.

3.8 Power Supply Decoupling

Flash memory's power switching characteristics require careful device decoupling. System designers should consider three supply current issues:

1. Standby current levels (I_{CCS})
2. Read current levels (I_{CCR})
3. Transient peaks produced by falling and rising edges of $CE\#$.

Transient current magnitudes depend on the device outputs' capacitive and inductive loading. Two-line control and proper decoupling capacitor selection will suppress these transient voltage peaks. Each flash device should have a 0.1 μF ceramic capacitor connected between each V_{CC} and GND, and between its V_{PP} and GND. These high-frequency, inherently low-inductance capacitors should be placed as close as possible to the package leads.

PRODUCT PREVIEW

4.0 ABSOLUTE MAXIMUM RATINGS*

Extended Operating Temperature

During Read -40 °C to +85 °C

During Block Erase
and Program..... -40 °C to +85 °C

Temperature Under Bias -40 °C to +85 °C

Storage Temperature..... -65 °C to +125 °C

Voltage on Any Pin

(except V_{CC} and V_{PP})
with Respect to GND -0.5 V to +5.0 V¹

V_{PP} Voltage (for Block

Erase and Program)
with Respect to GND -0.5 V to +13.5 V^{1,2,4}

V_{CC} and V_{CCQ} Supply Voltage

with Respect to GND -0.2 V to +5.0 V¹

Output Short Circuit Current..... 100 mA³

NOTICE: This datasheet contains preliminary information on products in the design phase of development. The specifications are subject to change without notice. Verify with your local Intel Sales office that you have the latest datasheet before finalizing a design.

* **WARNING:** *Stressing the device beyond the "Absolute Maximum Ratings" may cause permanent damage. These are stress ratings only. Operation beyond the "Operating Conditions" is not recommended and extended exposure beyond the "Operating Conditions" may effect device reliability.*

NOTES:

1. Minimum DC voltage is -0.5 V on input/output pins. During transitions, this level may undershoot to -2.0 V for periods < 20 ns. Maximum DC voltage on input/output pins is $V_{CC} + 0.5$ V which, during transitions, may overshoot to $V_{CC} + 2.0$ V for periods < 20 ns.
2. Maximum DC voltage on V_{PP} may overshoot to +14.0 V for periods < 20 ns.
3. Output shorted for no more than one second. No more than one output shorted at a time.
4. V_{PP} voltage is normally 1.65 V–3.6 V. Connection to supply of 11.4 V–12.6 V can only be done for 1000 cycles on the main blocks and 2500 cycles on the parameter blocks during program/erase. V_{PP} may be connected to 12 V for a total of 80 hours maximum. See Section 3.5 for details.

4.2 Operating Conditions

Table 10. Temperature and Voltage Operating Conditions

Symbol	Parameter	Notes	Min	Max	Units
T_A	Operating Temperature		-40	+85	°C
V_{CC1}	V _{CC} Supply Voltage	1	2.7	3.6	Volts
V_{CC2}		1	3.0	3.6	
V_{CCQ1}	I/O Supply Voltage	1	2.7	3.6	Volts
V_{PP1}	Supply Voltage	1	1.65	3.6	Volts
V_{PP2}		1, 2	11.4	12.6	Volts
Cycling	Block Erase Cycling	2	100,000		Cycles

NOTES:

1. V_{CC} and V_{CCQ} must share the same supply when they are in the V_{CC1} range.
2. Applying $V_{PP} = 11.4$ V–12.6 V during a program/erase can only be done for a maximum of 1000 cycles on the main blocks and 2500 cycles on the parameter blocks. V_{PP} may be connected to 12 V for a total of 80 hours maximum. See Section 3.5 for details.

4.3 Capacitance

$T_A = 25\text{ }^\circ\text{C}$, $f = 1\text{ MHz}$

Sym	Parameter	Notes	Typ	Max	Units	Conditions
C_{IN}	Input Capacitance	1	6	8	pF	$V_{IN} = 0\text{ V}$
C_{OUT}	Output Capacitance	1	10	12	pF	$V_{OUT} = 0\text{ V}$

NOTE:

1. Sampled, not 100% tested.

4.4 DC Characteristics

Sym	Parameter	V_{CC}	2.7 V–3.6 V		Unit	Test Conditions
		V_{CCQ}	2.7 V–3.6 V			
		Note	Typ	Max		
I_{LI}	Input Load Current	1,7		± 1	μA	$V_{CC} = V_{CCMax}$ $V_{CCQ} = V_{CCQMax}$ $V_{IN} = V_{CCQ}$ or GND
I_{LO}	Output Leakage Current	1,7	0.2	± 10	μA	$V_{CC} = V_{CCMax}$ $V_{CCQ} = V_{CCQMax}$ $V_{IN} = V_{CCQ}$ or GND
I_{CCS}	V_{CC} Standby Current	1	10	25	μA	$V_{CC} = V_{CCMax}$ $CE\# = RP\# = V_{CC}$
I_{CCD}	V_{CC} Deep Power-Down Current	1,7	7	20	μA	$V_{CC} = V_{CCMax}$ $V_{CCQ} = V_{CCQMax}$ $V_{IN} = V_{CCQ}$ or GND $RP\# = GND \pm 0.2\text{ V}$
I_{CCR}	V_{CC} Read Current	1,5,7	9	18	mA	$V_{CC} = V_{CCMax}$ $V_{CCQ} = V_{CCQMax}$ $OE\# = V_{IH}$, $CE\# = V_{IL}$ $f = 5\text{ MHz}$, $I_{OUT} = 0\text{ mA}$ Inputs = V_{IL} or V_{IH}
I_{CCW}	V_{CC} Program Current	1,4	18	55	mA	$V_{PP} = V_{PP1}$ Program in Progress
			8	15	mA	$V_{PP} = V_{PP2} (12\text{ V})$ Program in Progress
I_{CCE}	V_{CC} Erase Current	1,4	16	45	mA	$V_{PP} = V_{PP1}$ Erase in Progress
			8	15	mA	$V_{PP} = V_{PP2} (12\text{ V})$ Erase in Progress
I_{CCES}	V_{CC} Erase Suspend Current	1,2,4	10	25	μA	$CE\# = V_{IH}$, Erase Suspend in Progress
I_{CCWS}	V_{CC} Program Suspend Current	1,2,4	10	25	μA	$CE\# = V_{IH}$, Program Suspend in Progress

4.4 DC Characteristics, Continued

Sym	Parameter	V _{CC}	2.7 V–3.6 V		Unit	Test Conditions
		V _{CCQ}	2.7 V–3.6 V			
		Note	Typ	Max		
I _{PPD}	V _{PP} Deep Power-Down Current	1	0.2	5	μA	RP# = GND ± 0.2 V
I _{PPS}	V _{PP} Standby Current	1	0.2	5	μA	V _{PP} ≤ V _{CC}
I _{PPR}	V _{PP} Read Current	1	2	±15	μA	V _{PP} ≤ V _{CC}
		1,4	50	200	μA	V _{PP} ≥ V _{CC}
I _{PPW}	V _{PP} Program Current	1,4	0.05	0.1	mA	V _{PP} = V _{PP1} Program in Progress
			8	22	mA	V _{PP} = V _{PP2} (12 V) Program in Progress
I _{PPE}	V _{PP} Erase Current	1,4	0.05	0.1	mA	V _{PP} = V _{PP1} Program in Progress
			8	22	mA	V _{PP} = V _{PP2} (12 V) Program in Progress
I _{PPES}	V _{PP} Erase Suspend Current	1,4	0.2	5	μA	V _{PP} = V _{PP1} Erase Suspend in Progress
			50	200	μA	V _{PP} = V _{PP2} (12 V) Erase Suspend in Progress
I _{PPWS}	V _{PP} Program Suspend Current	1,4	0.2	5	μA	V _{PP} = V _{PP1} Program Suspend in Progress
			50	200	μA	V _{PP} = V _{PP2} (12 V) Program Suspend in Progress

4.4 DC Characteristics, Continued

Sym	Parameter	V _{CC}	2.7 V–3.6 V		Unit	Test Conditions
		V _{CCQ}	2.7 V–3.6 V			
		Note	Min	Max		
V _{IL}	Input Low Voltage		-0.4	0.4	V	
V _{IH}	Input High Voltage		V _{CCQ} - 0.4 V		V	
V _{OL}	Output Low Voltage	7	-0.10	0.10	V	V _{CC} = V _{CCMin} V _{CCQ} = V _{CCQMin} I _{OL} = 100 μA
V _{OH}	Output High Voltage	7	V _{CCQ} - 0.1 V		V	V _{CC} = V _{CCMin} V _{CCQ} = V _{CCQMin} I _{OH} = -100 μA
V _{PPLK}	V _{PP} Lock-Out Voltage	3		1.0	V	Complete Write Protection
V _{PP1}	V _{PP} during Program / Erase Operations	3	1.65	3.6	V	
V _{PP2}		3,6	11.4	12.6		
V _{LKO}	V _{CC} Prog/Erase Lock Voltage		1.5		V	
V _{LKO2}	V _{CCQ} Prog/Erase Lock Voltage		1.2		V	

NOTES:

- All currents are in RMS unless otherwise noted. Typical values at nominal V_{CC}, T_A = +25 °C.
- I_{CCES} and I_{CCWS} are specified with device de-selected. If device is read while in erase suspend, current draw is sum of I_{CCES} and I_{CCR}. If the device is read while in program suspend, current draw is the sum of I_{CCWS} and I_{CCR}.
- Erase and Program are inhibited when V_{PP} < V_{PPLK} and not guaranteed outside the valid V_{PP} ranges of V_{PP1} and V_{PP2}.
- Sampled, not 100% tested.
- Automatic Power Savings (APS) reduces I_{CCR} to approximately standby levels in static operation (CMOS inputs).
- Applying V_{PP} = 11.4 V–12.6 V during program/erase can only be done for a maximum of 1000 cycles on the main blocks and 2500 cycles on the parameter blocks. V_{PP} may be connected to 12 V for a total of 80 hours maximum. See Section 3.4 for details.
- The test conditions V_{CCMax}, V_{CCQMax}, V_{CCMin}, and V_{CCQMin} refer to the maximum or minimum V_{CC} or V_{CCQ} voltage listed at the top of each column.

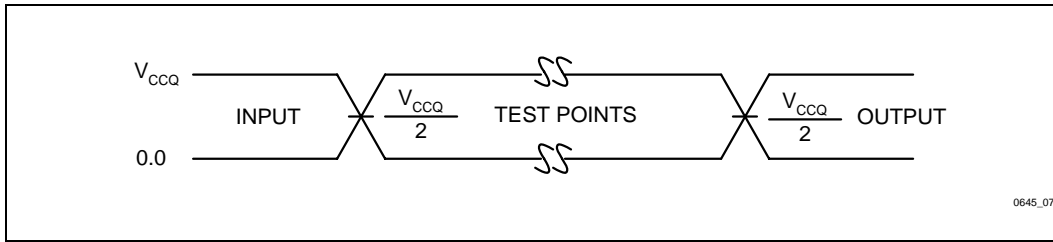

Figure 7. Input Range and Measurement Points

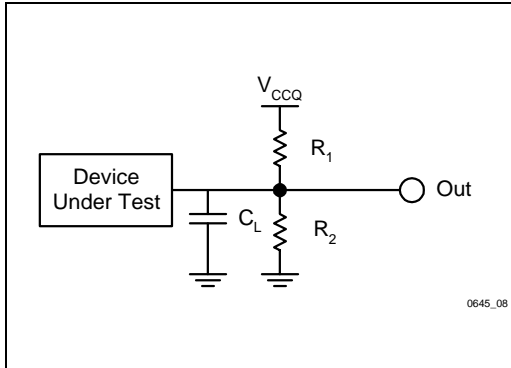

Figure 8. Test Configuration

Test Configuration Component Values Table

Test Configuration	C _L (pF)	R ₁ (Ω)	R ₂ (Ω)
2.7 V–3.6 V Standard Test	50	25K	25K

NOTE:
C_L includes jig capacitance.

4.5 AC Characteristics—Read Operations⁽¹⁾—Extended Temperature

#	Sym	Parameter	Note	Product		-90		-110				Unit		
				V _{CC}		3.0 V–3.6 V		2.7 V–3.6 V		3.0 V–3.6 V			2.7 V–3.6 V	
				Min	Max	Min	Max	Min	Max	Min	Max			
R1	t _{AVAV}	Read Cycle Time		80		90		100		110		ns		
R2	t _{AVQV}	Address to Output Delay			80		90		100		110	ns		
R3	t _{ELQV}	CE# to Output Delay	2		80		90		100		110	ns		
R4	t _{GLQV}	OE# to Output Delay	2		30		30		30		30	ns		
R5	t _{PHQV}	RP# to Output Delay			150		150		150		150	ns		
R6	t _{ELQX}	CE# to Output in Low Z	3	0		0		0		0		ns		
R7	t _{GLQX}	OE# to Output in Low Z	3	0		0		0		0		ns		
R8	t _{EHQZ}	CE# to Output in High Z	3		20		20		20		20	ns		
R9	t _{GHQZ}	OE# to Output in High Z	3		20		20		20		20	ns		
R10	t _{OH}	Output Hold from Address, CE#, or OE# Change, Whichever Occurs First	3	0		0		0		0		ns		

NOTES:

1. See AC Waveform: Read Operations.
2. OE# may be delayed up to t_{ELQV}–t_{GLQV} after the falling edge of CE# without impact on t_{ELQV}.
3. Sampled, but not 100% tested.
4. See Test Configuration (Figure 8).

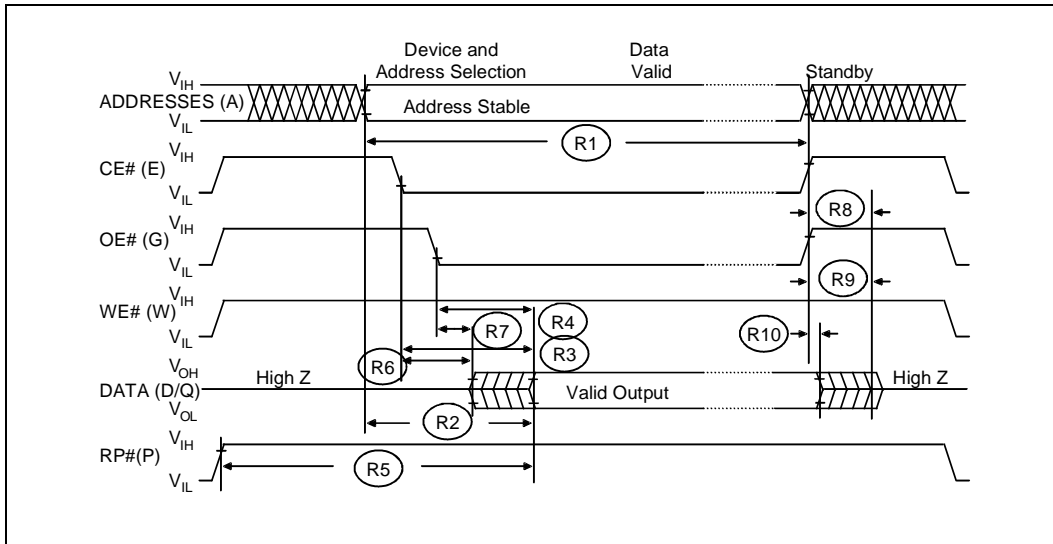

Figure 9. AC Waveform: Read Operations

4.6 AC Characteristics—Write Operations⁽¹⁾—Extended Temperature

#	Symbol	Parameter	Note	Product		-90		-110		Unit
				3.0 V – 3.6 V		80		100		
				2.7 V – 3.6 V			90		110	
				Min	Min	Min	Min			
W1	t_{PHWL} / t_{PHEL}	RP# High Recovery to WE# (CE#) Going Low		150	150	150	150	ns		
W2	t_{ELWL} / t_{WLEL}	CE# (WE#) Setup to WE# (CE#) Going Low		0	0	0	0	ns		
W3	t_{ELEH} / t_{WLWH}	WE# (CE#) Pulse Width	4	50	60	70	70	ns		
W4	t_{DVWH} / t_{DVEH}	Data Setup to WE# (CE#) Going High	2	50	50	60	60	ns		
W5	t_{AVWH} / t_{AVEH}	Address Setup to WE# (CE#) Going High	2	50	60	70	70	ns		
W6	t_{WHEH} / t_{EHWH}	CE# (WE#) Hold Time from WE# (CE#) High		0	0	0	0	ns		
W7	t_{WHDX} / t_{EHDX}	Data Hold Time from WE# (CE#) High	2	0	0	0	0	ns		
W8	t_{WHAX} / t_{EHAX}	Address Hold Time from WE# (CE#) High	2	0	0	0	0	ns		
W9	t_{WHWL} / t_{EHEL}	WE# (CE#) Pulse Width High	4	30	30	30	30	ns		
W10	t_{VPWH} / t_{VPEH}	V_{PP} Setup to WE# (CE#) Going High	3	200	200	200	200	ns		
W11	t_{QVVL}	V_{PP} Hold from Valid SRD	3	0	0	0	0	ns		

NOTES:

- Write timing characteristics during erase suspend are the same as during write-only operations.
- Refer to Table 5 for valid A_{IN} or D_{IN} .
- Sampled, but not 100% tested.
- Write pulse width (t_{WP}) is defined from CE# or WE# going low (whichever goes low last) to CE# or WE# going high (whichever goes high first). Hence, $t_{WP} = t_{WLWH} = t_{ELEH} = t_{WLEH} = t_{ELWH}$. Similarly, Write pulse width high (t_{WPH}) is defined from CE# or WE# going high (whichever goes high first) to CE# or WE# going low (whichever goes low first). Hence, $t_{WPH} = t_{WHWL} = t_{EHEL} = t_{WHEL} = t_{EHWL}$.
- See Test Configuration (Figure 8).

4.7 Erase and Program Timings⁽¹⁾

Symbol	Parameter	V _{PP}	1.65 V–3.6 V		11.4 V–12.6 V		Unit
		Note	Typ ⁽¹⁾	Max	Typ ⁽¹⁾	Max	
t _{BWPB}	8-KB Parameter Block Program Time (Byte)	2, 3	0.16	0.48	0.08	0.24	s
	4-KW Parameter Block Program Time (Word)	2, 3	0.10	0.30	0.03	0.12	s
t _{BWMB}	64-KB Main Block Program Time (Byte)	2, 3	1.2	3.7	0.6	1.7	s
	32-KW Main Block Program Time(Word)	2, 3	0.8	2.4	0.24	1	s
t _{WHQV1} / t _{EHQV1}	Byte Program Time	2, 3	17	165	8	185	μs
	Word Program Time	2, 3	22	200	8	185	μs
t _{WHQV2} / t _{EHQV2}	8-KB Parameter Block Erase Time (Byte)	2, 3	1	5	0.8	4.8	s
	4-KW Parameter Block Erase Time (Word)	2, 3	0.5	5	0.4	4.8	s
t _{WHQV3} / t _{EHQV3}	64-KB Main Block Erase Time (Byte)	2, 3	1	8	1	7	s
	32-KW Main Block Erase Time (Word)	2, 3	1	8	0.6	7	s
t _{WHRH1} / t _{EHRH1}	Program Suspend Latency	3	5	10	5	10	μs
t _{WHRH2} / t _{EHRH2}	Erase Suspend Latency	3	5	20	5	20	μs

NOTES:

1. Typical values measured at T_A = +25 °C and nominal voltages.
2. Excludes external system-level overhead.
3. Sampled, but not 100% tested.

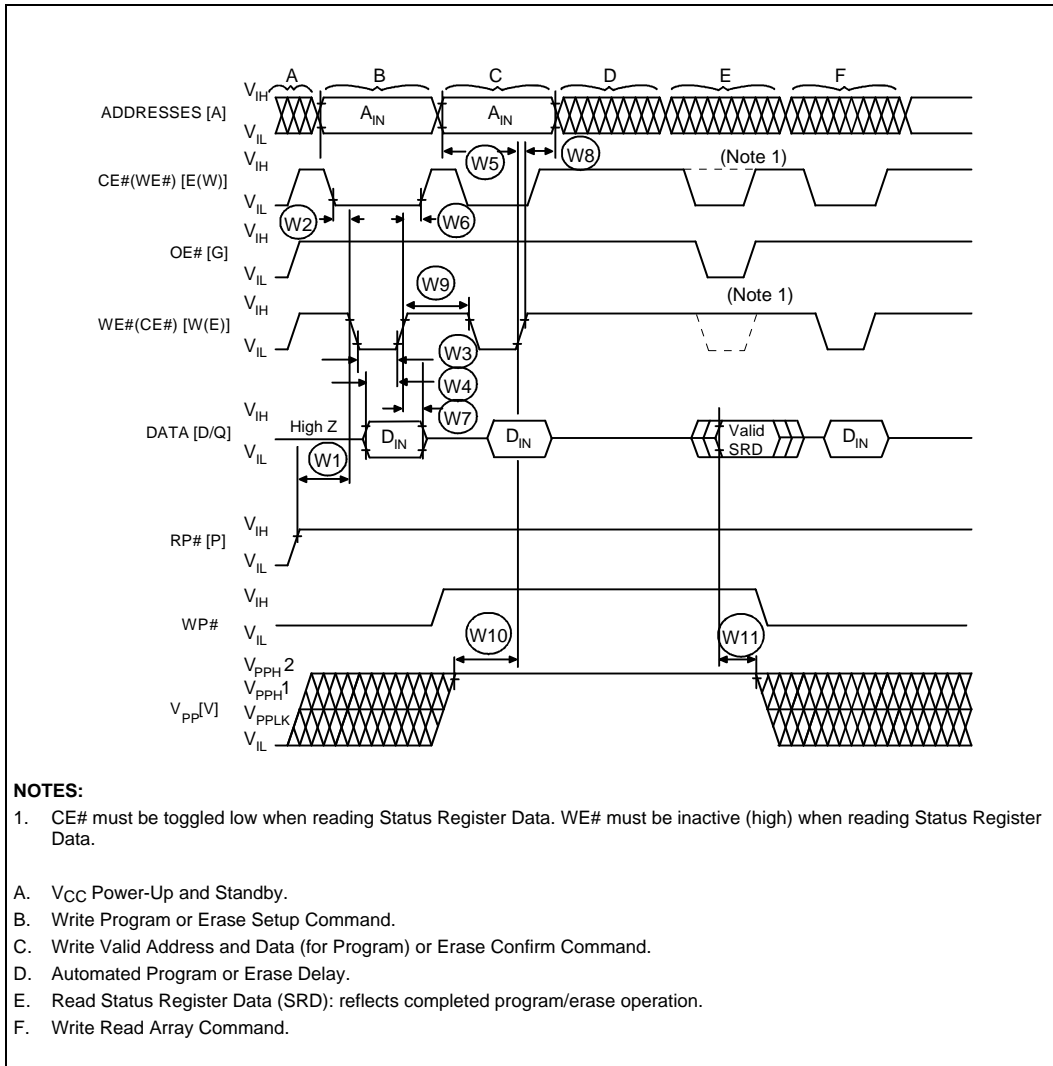

Figure 10. AC Waveform: Program and Erase Operations

4.8 Reset Operations

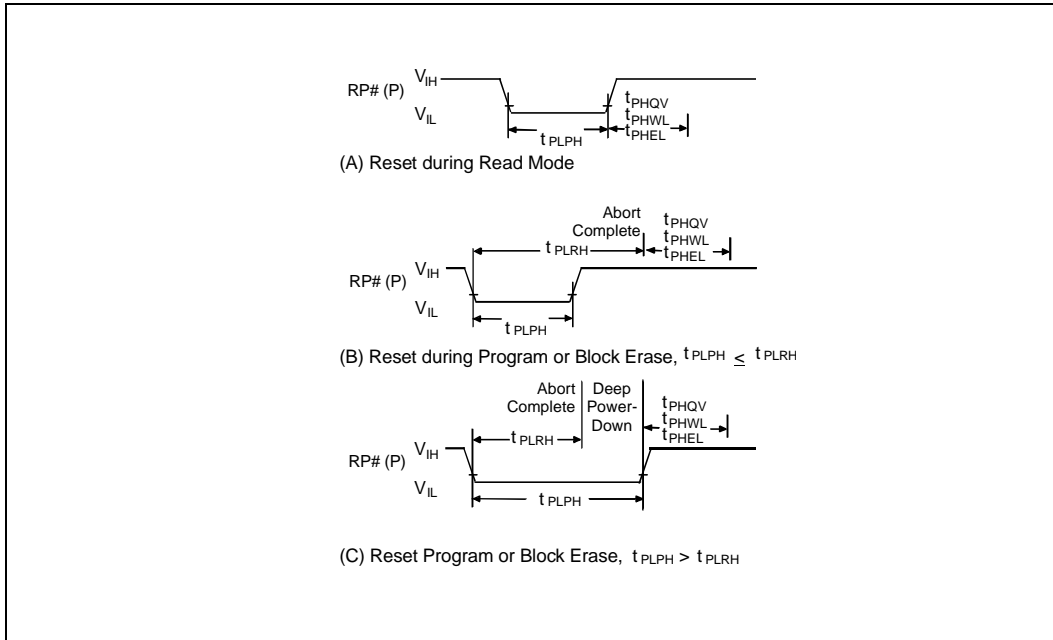

Figure 11. AC Waveform: Reset Operation

Table 11. Reset Specifications⁽¹⁾

Symbol	Parameter	Notes	V _{CC} 2.7V–3.6V		Unit
			Min	Max	
t _{PLPH}	RP# Low to Reset during Read (If RP# is tied to V _{CC} , this specification is not applicable)	2,4	100		ns
t _{PLRH1}	RP# Low to Reset during Block Erase	3,4		22	μs
t _{PLRH2}	RP# Low to Reset during Program	3,4		12	μs

NOTES:

1. See Section 3.1.4 for a full description of these conditions.
2. If t_{PLPH} is < 100 ns the device may still reset but this is not guaranteed.
3. If RP# is asserted while a block erase or word program operation is not executing, the reset will complete within 100 ns.
4. Sampled, but not 100% tested.

5.0 ORDERING INFORMATION

T	E	2	8	F	3	2	0	C	3	T	9	0
---	---	---	---	---	---	---	---	---	---	---	---	---

Package
TE = 48-Lead TSOP
GT = 48-Ball μ BGA* CSP

Product line designator
for all Intel® Flash products

Device Density
320 = x16 (32 Mbit)
032 = x8 (32 Mbit)
160 = x16 (16 Mbit)
800 = x16 (8 Mbit)
016 = x8 (16 Mbit)
008 = x8 (8 Mbit)

Access Speed (ns)
(90, 110)

T = Top Blocking
B = Bottom Blocking

Product Family
C3 = Advanced+ Boot Block
 $V_{CC} = 2.7\text{ V} - 3.6\text{ V}$
 $V_{PP} = 2.7\text{ V} - 3.6\text{ V}$ or $11.4\text{ V} - 12.6\text{ V}$

VALID COMBINATIONS (All Extended Temperature)

	40-Lead TSOP	48-Ball μ BGA* CSP ⁽¹⁾	48-Lead TSOP	48-Ball μ BGA CSP ⁽¹⁾
Extended 32M		GT28F032C3T90	TE28F320C3T90	GT28F320C3T90
		GT28F032C3B90	TE28F320C3B90	GT28F320C3B90
Extended 16M		GT28F032C3T110	TE28F320C3T110	GT28F320C3T110
		GT28F032C3B110	TE28F320C3B110	GT28F320C3B110
	TE28F016C3T90	GT28F016C3T90	TE28F160C3T90	GT28F160C3T90
	TE28F016C3B90	GT28F016C3B90	TE28F160C3B90	GT28F160C3B90
Extended 8M	TE28F016C3T110	GT28F016C3T110	TE28F160C3T110	GT28F160C3T110
	TE28F016C3B110	GT28F016C3B110	TE28F160C3B110	GT28F160C3B110
	TE28F008C3T90		TE28F800C3T90	
	TE28F008C3B90		TE28F800C3B90	
Extended 8M	TE28F008C3T110		TE28F800C3T110	
	TE28F008C3B110		TE28F800C3B110	

NOTE:

1. The 48-Ball μ BGA package top side mark reads FXX0C3 where XX is the device density. This mark is identical for both x8 and x16 products. All product shipping boxes or trays provide the correct information regarding bus architecture, however once the devices are removed from the shipping media, it may be difficult to differentiate based on the top side mark. The device identifier (accessible through the Device ID command: see Section 3.2.2 for further details) enables x8 and x16 μ BGA package product differentiation.

6.0 ADDITIONAL INFORMATION(1,2)

Order Number	Document/Tool
210830	<i>1998 Flash Memory Databook</i>
292216	<i>AP-658 Designing for Upgrade to the Advanced+ Boot Block Flash Memory</i>
292215	<i>AP-657 Designing with the Advanced+ Boot Block Flash Memory Architecture</i>
	<i>3 Volt Advanced+ Boot Block Algorithms ('C' and assembly)</i> http://developer.intel.com/design/flcomp
Contact your Intel Representative	<i>Flash Data Integrator (FDI) Software Developer's Kit</i>
297874	<i>FDI Interactive: Play with Intel's Flash Data Integrator on Your PC</i>

NOTES:

1. Please call the Intel Literature Center at (800) 548-4725 to request Intel documentation. International customers should contact their local Intel or distribution sales office.
2. Visit Intel's World Wide Web home page at <http://www.intel.com> or <http://developer.intel.com> for technical documentation and tools.

APPENDIX A WSM CURRENT/NEXT STATES

Current State	SR.7	Data When Read	Command Input (and Next State)								
			Read Array (FFH)	Program Setup (10/40H)	Erase Setup (20H)	Erase Confirm (D0H)	Prog/Ers Suspend (B0H)	Prog/Ers Resume (D0)	Read Status (70H)	Clear Status (50H)	
Read Array	"1"	Array	Read Array	Program Setup	Erase Setup	Read Array			Read Status	Read Array	
Read Status	"1"	Status	Read Array	Program Setup	Erase Setup	Read Array			Read Status	Read Array	
Read Config.	"1"	Config	Read Array	Program Setup	Erase Setup	Read Array			Read Status	Read Array	
Read Query	"1"	CFI	Read Array	Program Setup	Erase Setup	Read Array			Read Status	Read Array	
Lock Setup	"1"	Status	Lock Command Error			Lock (Done)	Lock Cmd. Error	Lock (Done)	Lock Cmd. Error		
Lock Cmd. Error	"1"	Status	Read Array	Program Setup	Erase Setup	Read Array			Read Status	Read Array	
Lock Oper. (Done)	"1"	Status	Read Array	Program Setup	Erase Setup	Read Array			Read Status	Read Array	
Prot. Prog. Setup	"1"	Status	Protection Register Program								
Prot. Prog. (Not Done)	"0"	Status	Protection Register Program (Not Done)								
Prot. Prog. (Done)	"1"	Status	Read Array	Program Setup	Erase Setup	Read Array			Read Status	Read Array	
Prog. Setup	"1"	Status	Program								
Program (Not Done)	"0"	Status	Program (Not Done)				Prog. Sus. Status	Program (Not Done)			
Prog. Susp. Status	"1"	Status	Prog. Sus. Read Array	Program Suspend Read Array		Program (Not Done)	Prog. Sus. Rd. Array	Program (Not Done)	Prog. Sus. Status	Prog. Sus. Rd. Array	
Prog. Susp. Read Array	"1"	Array	Prog. Sus. Read Array	Program Suspend Read Array		Program (Not Done)	Prog. Sus. Rd. Array	Program (Not Done)	Prog. Sus. Status	Prog. Sus. Rd. Array	
Prog. Susp. Read Config	"1"	Config	Prog. Sus. Read Array	Program Suspend Read Array		Program (Not Done)	Prog. Sus. Rd. Array	Program (Not Done)	Prog. Sus. Status	Prog. Sus. Rd. Array	
Prog. Susp. Read Query	"1"	CFI	Prog. Sus. Read Array	Program Suspend Read Array		Program (Not Done)	Prog. Sus. Rd. Array	Program (Not Done)	Prog. Sus. Status	Prog. Sus. Rd. Array	
Program (Done)	"1"	Status	Read Array	Program Setup	Erase Setup	Read Array			Read Status	Read Array	
Erase Setup	"1"	Status	Erase Command Error			Erase (Not Done)	Erase Cmd. Error	Erase (Not Done)	Erase Command Error		
Erase Cmd. Error	"1"	Status	Read Array	Program Setup	Erase Setup	Read Array			Read Status	Read Array	
Erase (Not Done)	"0"	Status	Erase (Not Done)				Erase Sus. Status	Erase (Not Done)			
Ers. Susp. Status	"1"	Status	Erase Sus. Read Array	Program Setup	Ers. Sus. Rd. Array	Erase	Ers. Sus. Rd. Array	Erase	Erase Sus. Status	Ers. Sus. Rd. Array	
Erase Susp. Array	"1"	Array	Erase Sus. Read Array	Program Setup	Ers. Sus. Rd. Array	Erase	Ers. Sus. Rd. Array	Erase	Erase Sus. Status	Ers. Sus. Rd. Array	
Ers. Susp. Read Config	"1"	Config	Erase Sus. Read Array	Program Setup	Ers. Sus. Rd. Array	Erase	Ers. Sus. Rd. Array	Erase	Erase Sus. Status	Ers. Sus. Rd. Array	
Ers. Susp. Read Query	"1"	CFI	Erase Sus. Read Array	Program Setup	Ers. Sus. Rd. Array	Erase	Ers. Sus. Rd. Array	Erase	Erase Sus. Status	Ers. Sus. Rd. Array	
Erase (Done)	"1"	Status	Read Array	Program Setup	Erase Setup	Read Array			Read Status	Read Array	

APPENDIX A WSM CURRENT/NEXT STATES (Continued)

Current State	Command Input (and Next State)						
	Read Config (90H)	Read Query (98H)	Lock Setup (60H)	Prot. Prog. Setup (C0H)	Lock Confirm (01H)	Lock Down Confirm (2FH)	Unlock Confirm (D0H)
Read Array	Read Config.	Read Query	Lock Setup	Prot. Prog. Setup	Read Array		
Read Status	Read Config.	Read Query	Lock Setup	Prot. Prog. Setup	Read Array		
Read Config.	Read Config.	Read Query	Lock Setup	Prot. Prog. Setup	Read Array		
Read Query	Read Config.	Read Query	Lock Setup	Prot. Prog. Setup	Read Array		
Lock Setup	Locking Command Error				Lock Operation (Done)		
Lock Cmd. Error	Read Config.	Read Query	Lock Setup	Prot. Prog. Setup	Read Array		
Lock Operation (Done)	Read Config.	Read Query	Lock Setup	Prot. Prog. Setup	Read Array		
Prot. Prog. Setup	Protection Register Program						
Prot. Prog. (Not Done)	Protection Register Program (Not Done)						
Prot. Prog. (Done)	Read Config.	Read Query	Lock Setup	Prot. Prog. Setup	Read Array		
Prog. Setup	Program						
Program (Not Done)	Program (Not Done)						
Prog. Susp. Status	Prog. Susp. Read Config.	Prog. Susp. Read Query	Program Suspend Read Array			Program (Not Done)	
Prog. Susp. Read Array	Prog. Susp. Read Config.	Prog. Susp. Read Query	Program Suspend Read Array			Program (Not Done)	
Prog. Susp. Read Config.	Prog. Susp. Read Config.	Prog. Susp. Read Query	Program Suspend Read Array			Program (Not Done)	
Prog. Susp. Read Query.	Prog. Susp. Read Config.	Prog. Susp. Read Query	Program Suspend Read Array			Program (Not Done)	
Program (Done)	Read Config.	Read Query	Lock Setup	Prot. Prog. Setup	Read Array		
Erase Setup	Erase Command Error					Erase (Not Done)	
Erase Cmd. Error	Read Config.	Read Query	Lock Setup	Prot. Prog. Setup	Read Array		
Erase (Not Done)	Erase (Not Done)						
Erase Suspend Status	Erase Suspend Read Config.	Erase Suspend Read Query	Lock Setup	Erase Suspend Read Array			Erase (Not Done)
Erase Suspend Array	Erase Suspend Read Config.	Erase Suspend Read Query	Lock Setup	Erase Suspend Read Array			Erase (Not Done)
Eras Sus. Read Config	Erase Suspend Read Config.	Erase Suspend Read Query	Lock Setup	Erase Suspend Read Array			Erase (Not Done)
Eras Sus. Read Query	Erase Suspend Read Config.	Erase Suspend Read Query	Lock Setup	Erase Suspend Read Array			Erase (Not Done)
Ers.(Done)	Read Config.	Read Query	Lock Setup	Prot. Prog. Setup	Read Array		

APPENDIX B PROGRAM/ERASE FLOWCHARTS

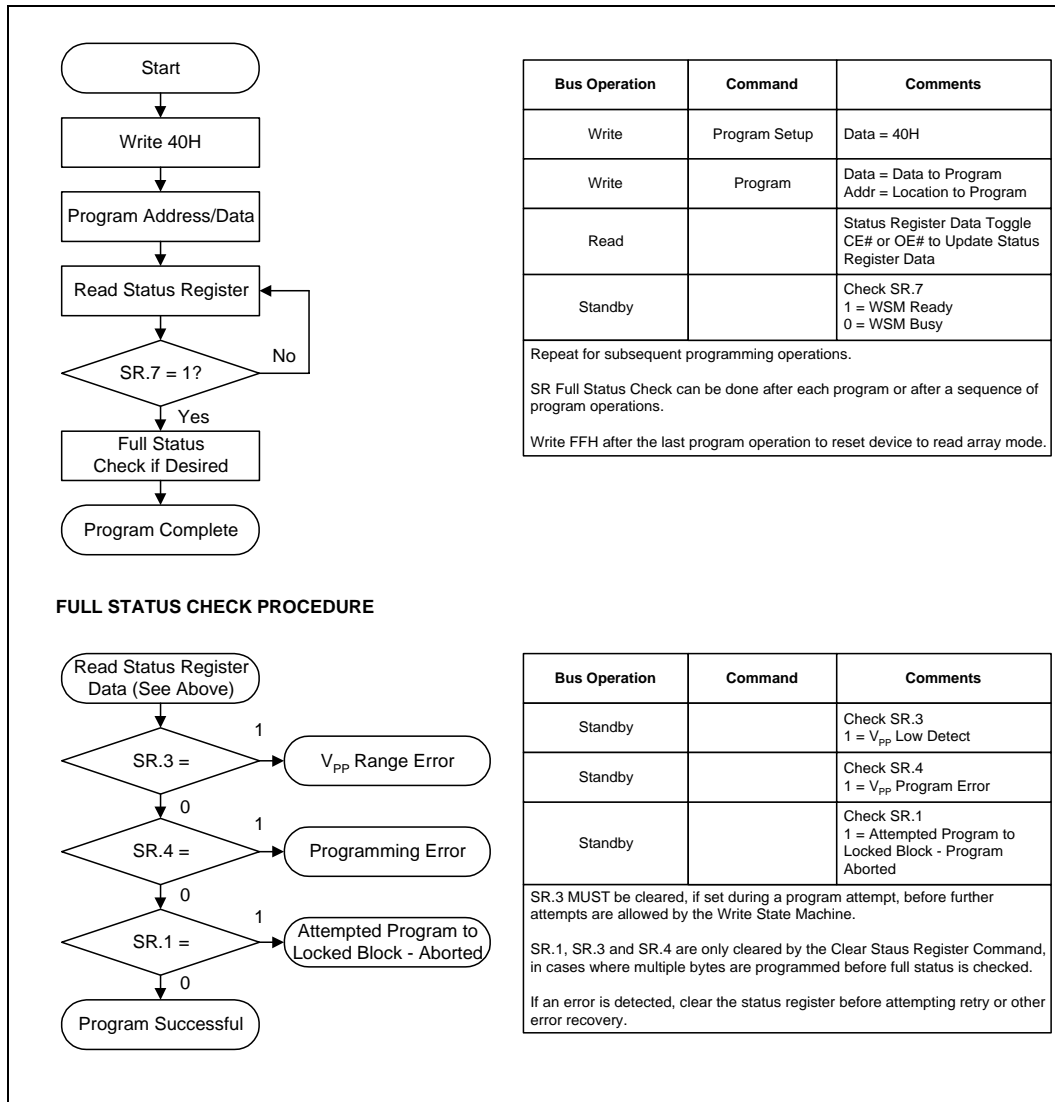

Figure 12. Automated Word Programming Flowchart

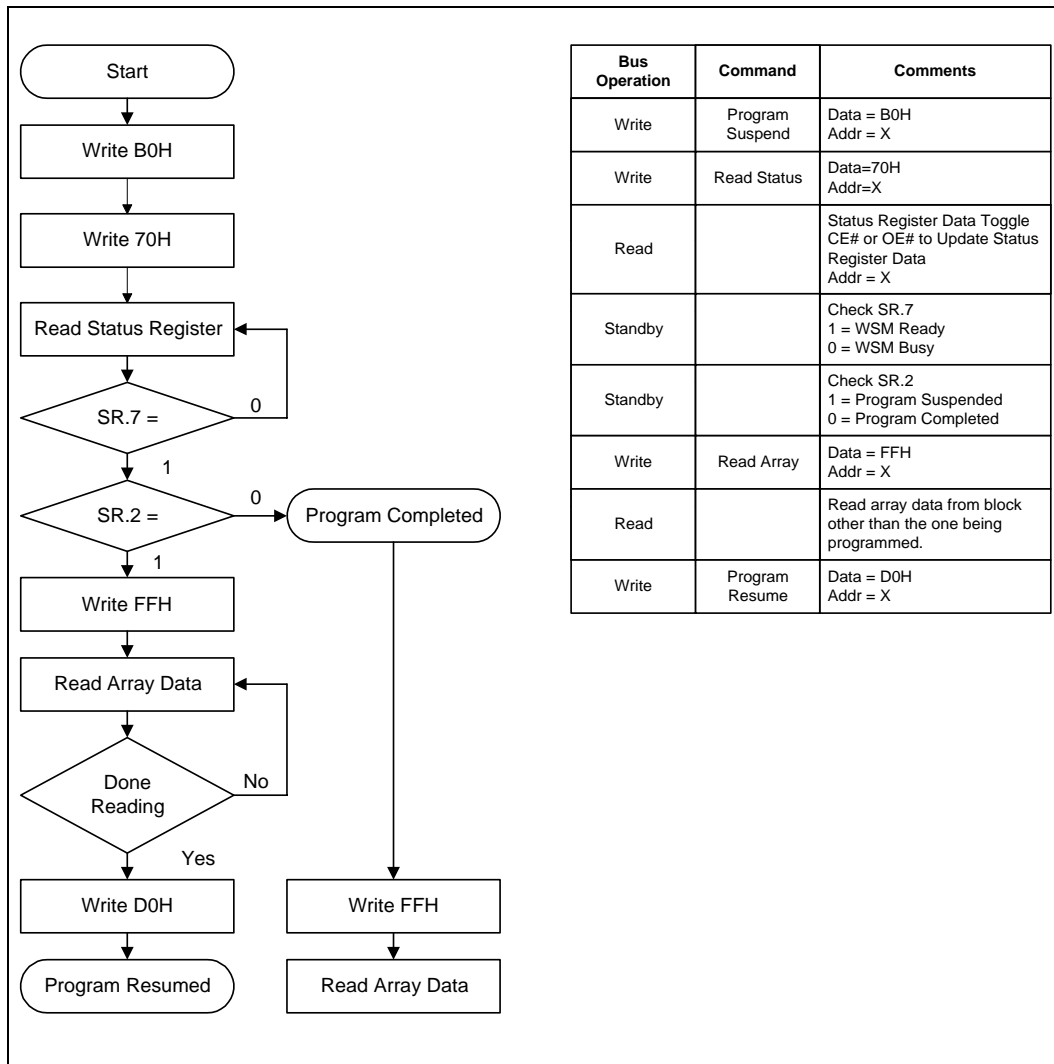

Figure 13. Program Suspend/Resume Flowchart

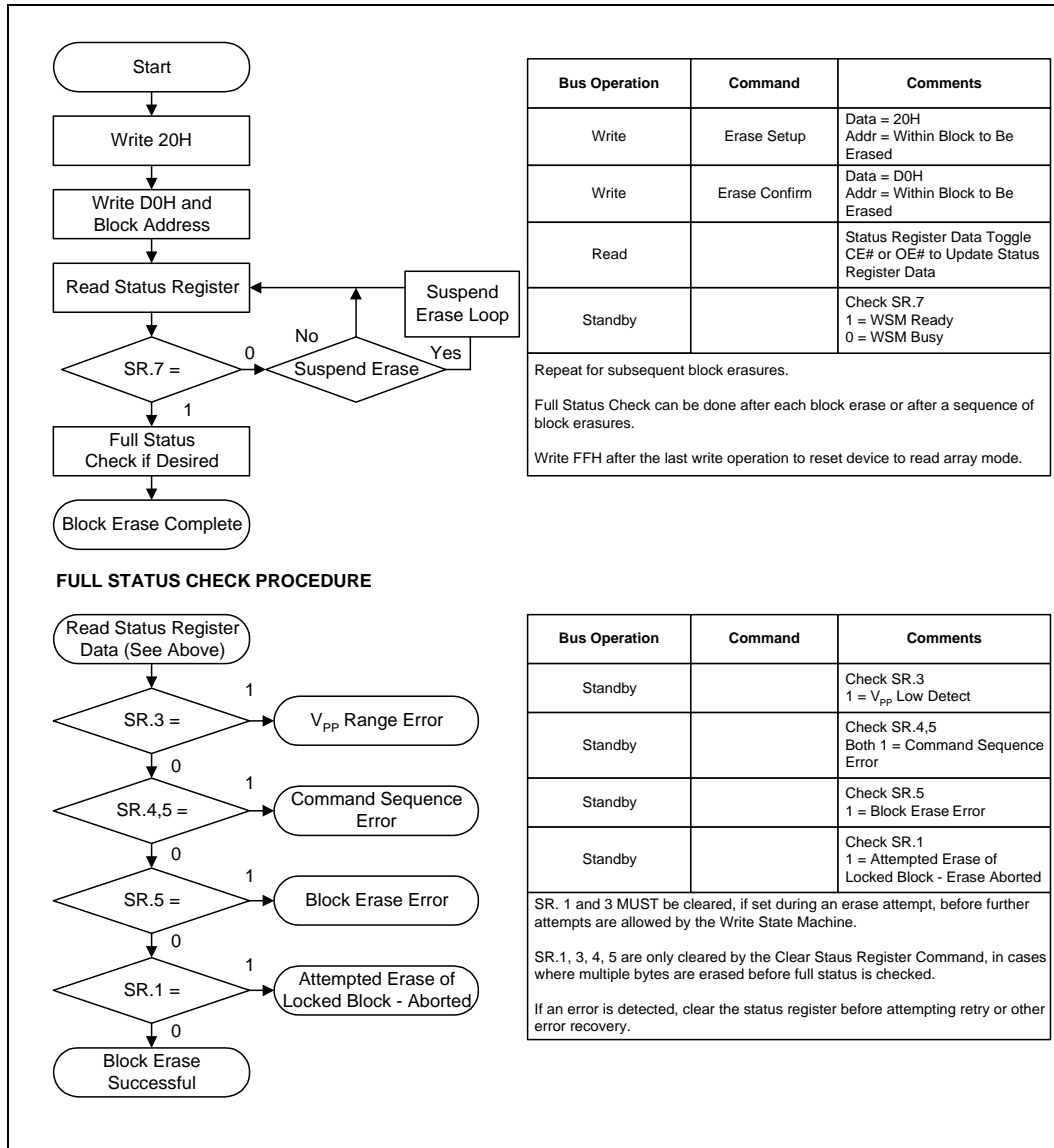
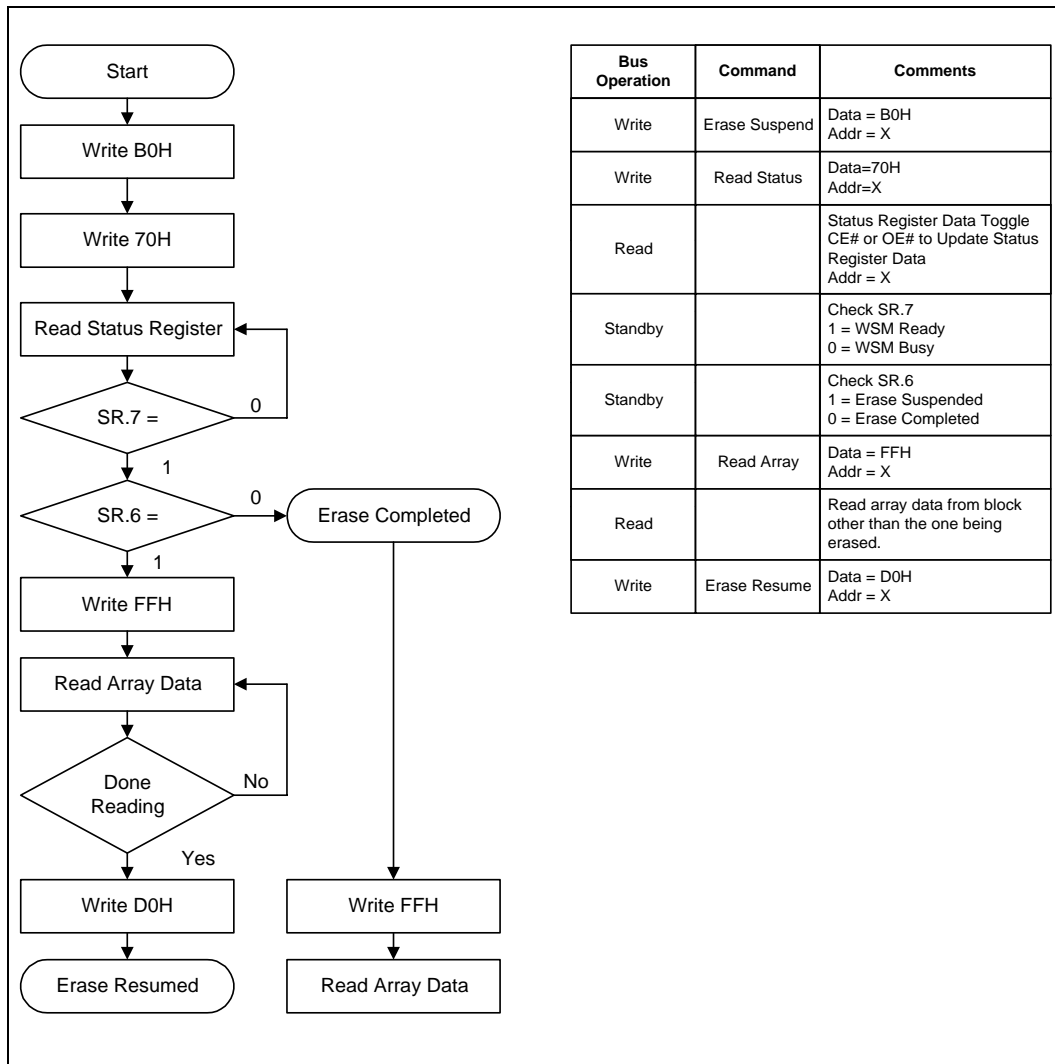
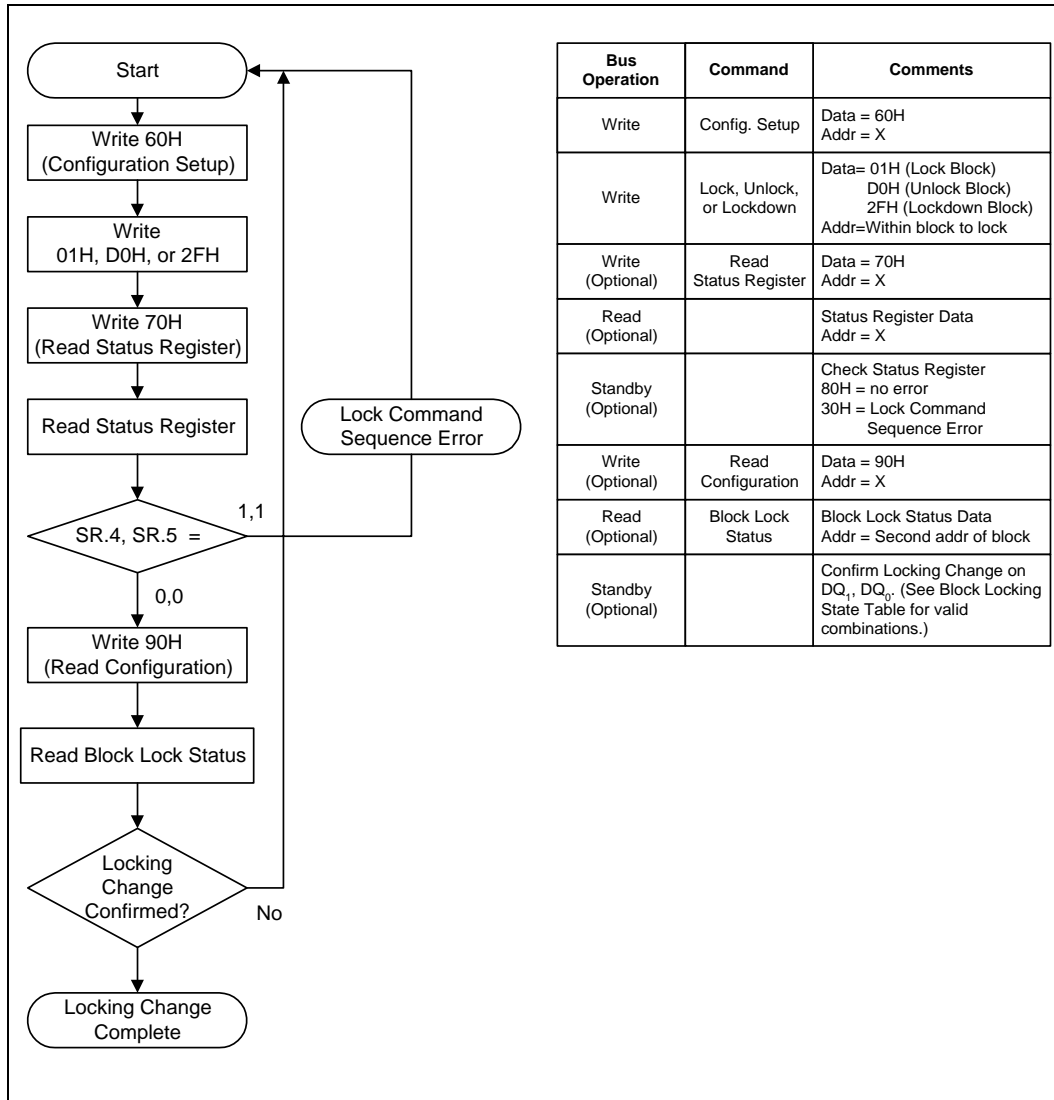

Figure 14. Automated Block Erase Flowchart



Bus Operation	Command	Comments
Write	Erase Suspend	Data = B0H Addr = X
Write	Read Status	Data=70H Addr=X
Read		Status Register Data Toggle CE# or OE# to Update Status Register Data Addr = X
Standby		Check SR.7 1 = WSM Ready 0 = WSM Busy
Standby		Check SR.6 1 = Erase Suspended 0 = Erase Completed
Write	Read Array	Data = FFH Addr = X
Read		Read array data from block other than the one being erased.
Write	Erase Resume	Data = D0H Addr = X

Figure 15. Erase Suspend/Resume Flowchart



Bus Operation	Command	Comments
Write	Config. Setup	Data = 60H Addr = X
Write	Lock, Unlock, or Lockdown	Data= 01H (Lock Block) D0H (Unlock Block) 2FH (Lockdown Block) Addr=Within block to lock
Write (Optional)	Read Status Register	Data = 70H Addr = X
Read (Optional)		Status Register Data Addr = X
Standby (Optional)		Check Status Register 80H = no error 30H = Lock Command Sequence Error
Write (Optional)	Read Configuration	Data = 90H Addr = X
Read (Optional)	Block Lock Status	Block Lock Status Data Addr = Second addr of block
Standby (Optional)		Confirm Locking Change on DQ ₁ , DQ ₂ . (See Block Locking State Table for valid combinations.)

Figure 16. Locking Operations Flowchart

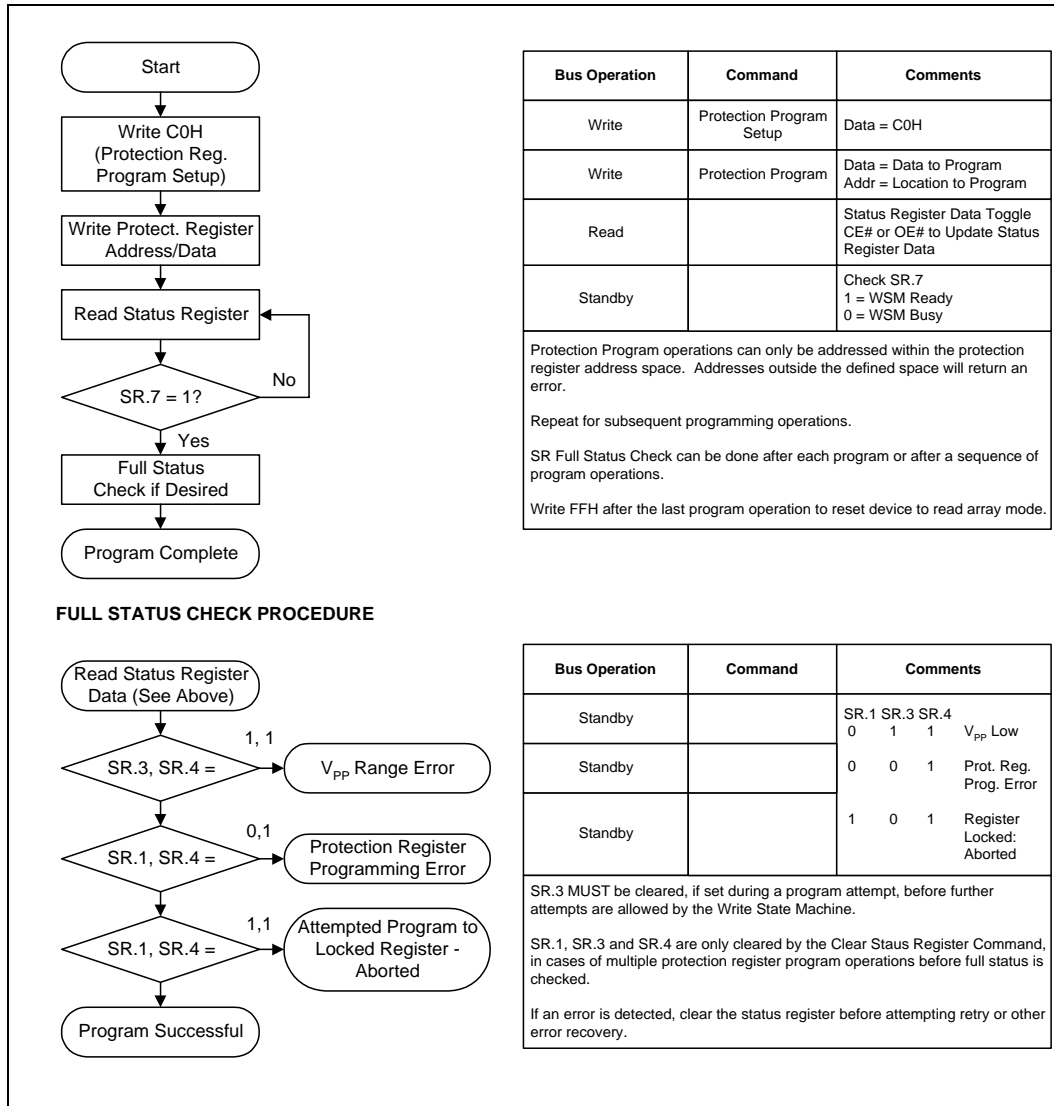

Figure 17. Protection Register Programming Flowchart

APPENDIX C

COMMON FLASH INTERFACE QUERY STRUCTURE

This appendix defines the data structure or “database” returned by the Common Flash Interface (CFI) Query command. System software should parse this structure to gain critical information such as block size, density, x8/x16, and electrical specifications. Once this information has been obtained, the software will know which command sets to use to enable flash writes, block erases, and otherwise control the flash component. The Query is part of an overall specification for multiple command set and control interface descriptions called Common Flash Interface, or CFI.

C.1 QUERY STRUCTURE OUTPUT

The Query “database” allows system software to gain critical information for controlling the flash component. This section describes the device’s CFI-compliant interface that allows the host system to access Query data.

Query data are always presented on the lowest-order data outputs (DQ₀₋₇) only. The numerical offset value is the address relative to the maximum bus width supported by the device. On this family of devices, the Query table device starting address is a 10h, which is a word address for x16 devices or a byte address for x8 devices.

For a word-wide (x16) device, the first two bytes of the Query structure, “Q”, “R”, and “Y” in ASCII, appear on the low byte at word addresses 10h, 11h, and 12h. This CFI-compliant device outputs 00H data on upper bytes. Thus, the device outputs ASCII “Q” in the low byte (DQ₀₋₇) and 00h in the high byte (DQ₈₋₁₅).

At Query addresses containing two or more bytes of information, the least significant data byte is presented at the lower address, and the most significant data byte is presented at the higher address.

In all of the following tables, addresses and data are represented in hexadecimal notation, so the “h” suffix has been dropped. In addition, since the upper byte of word.wide devices is always “00h,” the leading “00” has been dropped from the table notation and only the lower byte value is shown. Any x16 device outputs can be assumed to have 00h on the upper byte in this mode.

Table C1. Summary of Query Structure Output As a Function of Device and Mode

Device	Location	Query Data (Hex, ASCII)
8-Mbit x8/8-Mbit x 16, 16-Mbit x 8/16-Mbit x 16 (Word or Byte Addresses)	10	51 “Q”
	11	52 “R”
	12	59 “Y”

Table C2. Example of Query Structure Output of x16 and x8 Devices

Device Address	Word Addressing: Query Data	Byte Address	Byte Addressing: Query Data
A ₁₆ -A ₁	D ₁₅ -D ₀	A ₇ -A ₀	D ₇ -D ₀
0010h	0051h "Q"	10h	51h "Q"
0011h	0052h "R"	11h	52h "R"
0012h	0059h "Y"	12h	59h "Y"
0013h	P_ID _{LO} PrVendor ID# (Lo byte)	13h	P_ID _{LO} PrVendor ID# (Lo)
0014h	P_ID _{HI} PrVendor ID# (HI byte)	14h	P_ID _{HI} PrVendor ID# (Hi)
0015h	P _{LO} PrVendor TblAddr (Lo)	15h	P _{LO} PrVndr TblAdr (Lo)
0016h	P _{HI} PrVendor TblAddr (Hi)	16h	P _{HI} PrVndr TblAdr (Hi)
0017h	A_ID _{LO} AltVendor ID# (Lo)	17h	A_ID _{LO} AltVndr ID# (Lo)
0018h	A_ID _{HI} AltVendor ID# (Hi)	18h	A_ID _{HI} AltVndr ID# (Hi)
...

C.2 QUERY STRUCTURE OVERVIEW

The Query command causes the flash component to display the Common Flash Interface (CFI) Query structure or "database." The structure sub-sections and address locations are summarized in Table D3.

The following sections describe the Query structure sub-sections in detail.

Table C3. Query Structure⁽¹⁾

Offset	Sub-Section Name	Description
00h		Manufacturer Code
01h		Device Code
02-0Fh	<i>Reserved</i>	<i>Reserved for vendor-specific information</i>
10h	CFI Query Identification String	Command set ID and vendor data offset
1Bh	System Interface Information	Device timing & voltage information
27h	Device Geometry Definition	Flash device layout
P ⁽³⁾	Primary Intel-specific Extended Query table	Vendor-defined additional information specific to the Primary Vendor Algorithm

NOTES:

1. Refer to Section D.1 and Table D1 for the detailed definition of offset address as a function of device bus width and mode.
2. BA = The beginning location of a Block Address (e.g., 08000h is the beginning location of block 1 when the block size is 32 Kword).
3. Offset 15 defines "P" which points to the Primary Intel-specific Extended Query Table.

C.3 BLOCK LOCK STATUS

The Block Lock Status indicates the locking settings of a block.

Table C4. Block Lock Status Register

Offset	Length (bytes)	Description	C3 x16 Device/Mode
(BA+2)h ⁽¹⁾	01h	Block Lock Status	BA+2: (see Section 3.3)

NOTE:

1. BA = The beginning location of a Block Address (i.e., 008000h is the beginning location of block 1 in word mode.)

C.4 CFI QUERY IDENTIFICATION STRING

The Identification String provides verification that the component supports the Common Flash Interface specification. Additionally, it indicates which version of the spec and which vendor-specified command set(s) is (are) supported.

Table C5. CFI Identification

Offset	Length (Bytes)	Description	8-Mbit, 16-Mbit, 32-Mbit
10h	03h	Query-Unique ASCII string "QRY"	10: 51 11: 52 12: 59
13h	02h	Primary Vendor Command Set and Control Interface ID Code 16-bit ID Code for Vendor-Specified Algorithms	13: 03 14: 00
15h	02h	Address for Primary Algorithm Extended Query Table Offset value = $P = 35h$	15: 35 16: 00
17h	02h	Alternate Vendor Command Set and Control Interface ID Code Second Vendor-Specified Algorithm Supported Note: 0000h means none exists	17: 00 18: 00
19h	02h	Address for Secondary Algorithm Extended Query Table Note: 0000h means none exists	19: 00 1A: 00

C.5 SYSTEM INTERFACE INFORMATION

The following device information can be useful in optimizing system interface software

Table C6. System Interface Information

Offset	Length (bytes)	Description	8-Mbit, 16-Mbit, 32-Mbit
1Bh	01h	V _{CC} Logic Supply Minimum Program/Erase Voltage bits 7–4 BCD volts bits 3–0 BCD 100 mv	1B:27
1Ch	01h	V _{CC} Logic Supply Maximum Program/Erase Voltage bits 7–4 BCD volts bits 3–0 BCD 100 mv	1C:36
1Dh	01h	V _{PP} [Programming] Supply Minimum Program/Erase Voltage bits 7–4 HEX volts bits 3–0 BCD 100 mv	1D:B4
1Eh	01h	V _{PP} [Programming] Supply Maximum Program/Erase Voltage bits 7–4 HEX volts bits 3–0 BCD 100 mv	1E:C6
1Fh	01h	Typical Time-Out per Single Byte/Word Program, 2 ^N μ-sec	1F:05
20h	01h	Typical Time-Out for Max. Buffer Write, 2 ^N μ-sec	20:00
21h	01h	Typical Time-Out per Individual Block Erase, 2 ^N m-sec	21:0A
22h	01h	Typical Time-Out for Full Chip Erase, 2 ^N m-sec	22:00
23h	01h	Maximum Time-Out for Byte/Word Program, 2 ^N Times Typical	23:04
24h	01h	Maximum Time-Out for Buffer Write, 2 ^N Times Typical	24:00
25h	01h	Maximum Time-Out per Individual Block Erase, 2 ^N Times Typical	25:03
26h	01h	Maximum Time-Out for Chip Erase, 2 ^N Times Typical	26:00

C.6 DEVICE GEOMETRY DEFINITION

This field provides critical details of the flash device geometry.

Table C7. Device Geometry Definition

Offset	Length (bytes)	Description						
27h	01h	Device Size = 2 ^N in Number of Bytes						
28h	02h	Flash Device Interface Description <table border="0"> <tr> <td><u>value</u></td> <td><u>meaning</u></td> </tr> <tr> <td>28:00, 29:00</td> <td>x8 asynch</td> </tr> <tr> <td>28:01,29:00</td> <td>x16 asynch</td> </tr> </table>	<u>value</u>	<u>meaning</u>	28:00, 29:00	x8 asynch	28:01,29:00	x16 asynch
<u>value</u>	<u>meaning</u>							
28:00, 29:00	x8 asynch							
28:01,29:00	x16 asynch							
2Ah	02h	Maximum Number of Bytes in Write Buffer = 2 ^N						
2Ch	01h	Number of Erase Block Regions within Device: bits 7–0 = x = # of Erase Block Regions						
2Dh	04h	Erase Block Region Information bits 15–0 = y , Where y+1 = Number of Erase Blocks of Identical Size within Region bits 31–16 = z , Where the Erase Block(s) within This Region are (z) × 256 Bytes						

Device Geometry Definition

Offset	8 Mbit		16 Mbit		32 Mbit	
	-T	-B	-T	-B	-T	-B
27h	27:14	27:14	27:15	27:15	27:16	27:16
28h	28:00 (008) 29:00 (008) 28:01 (800) 29:00 (800)	28:00 (008) 29:00 (008) 28:01 (800) 29:00 (800)	28:00 (016) 29:00 (016) 28:01 (160) 29:00 (160)	28:00 (016) 29:00 (016) 28:01 (160) 29:00 (160)	28:00 (032) 29:00 (032) 28:01 (320) 29:00 (320)	28:00 (032) 29:00 (032) 28:01 (320) 29:00 (320)
2Ah	2A:00 2B:00	2A:00 2B:00	2A:00 2B:00	2A:00 2B:00	2A:00 2B:00	2A:00 2B:00
2Ch	2C:02	2C:02	2C:02	2C:02	2C:02	2C:02
2Dh	2D:0E 2E:00 2F:00 30:01 31:07 32:00 33:20 34:00	2D:07 2E:00 2F:20 30:00 31:0E 32:00 33:00 34:01	2D:1E 2E:00 2F:00 30:01 31:07 32:00 33:20 34:00	2D:07 2E:00 2F:20 30:00 31:1E 32:00 33:00 34:01	2D:3E 2E:00 2F:00 30:01 31:07 32:00 33:20 34:00	2D:07 2E:00 2F:20 30:00 31:3E 32:00 33:00 34:01

C.7 INTEL-SPECIFIC EXTENDED QUERY TABLE

Certain flash features and commands are optional. The Intel-Specific Extended Query table specifies this and other similar types of information.

Table C8. Primary-Vendor Specific Extended Query

Offset ⁽¹⁾	Length (bytes)	Description	8-Mbit, 16-Mbit, 32-Mbit
(P)h	03h	Primary Extended Query Table Unique ASCII String "PRI"	35: 50 36: 52 37: 49
(P+3)h	01h	Major Version Number, ASCII	38: 31
(P+4)h	01h	Minor Version Number, ASCII	39: 30
(P+5)h	04h	Optional Feature & Command Support bit 0 Chip Erase Supported (1=yes, 0=no) bit 1 Suspend Erase Supported (1=yes, 0=no) bit 2 Suspend Program Supported (1=yes, 0=no) bit 3 Lock/Unlock Supported (1=yes, 0=no) bit 4 Queued Erase Supported (1=yes, 0=no) <i>bits 5–31 reserved for future use; undefined bits are "0"</i>	3A: 06 3B: 00 3C: 00 3D: 00
(P+9)h	01h	Supported Functions after Suspend Read Array, Status, and Query are always supported during suspended Erase or Program operation. This field defines other operations supported. bit 0 Program Supported after Erase Suspend (1=yes, 0=no) <i>bits 1-7 reserved for future use; undefined bits are "0"</i>	3E: 01
(P+A)h	02h	Block Lock Status Defines which bits in the Block Status Register section of the Query are implemented. bit 0 Block Lock Status Register Lock/Unlock bit (bit 0) active (1=yes, 0=no) bit 1 Block Lock Status Register Lock-Down bit (bit 1) active (1=yes, 0=no) <i>Bits 2—15 reserved for future use. Undefined bits are 0.</i>	3F: 03 40: 00

Table C8. Primary-Vendor Specific Extended Query (Continued)

Offset ⁽¹⁾	Length (bytes)	Description	8-Mbit, 16-Mbit, 32-Mbit
(P+C)h	01h	V _{CC} Logic Supply Optimum Program/Erase voltage (highest performance) bits 7–4 BCD value in volts bits 3–0 BCD value in 100 mv	41: 27
(P+D)h	01h	V _{PP} [Programming] Supply Optimum Program/Erase voltage bits 7–4 HEX value in volts bits 3–0 BCD value in 100 mv	42: C0
(P+E)h	<i>Reserved</i>	<i>Reserved for future use</i>	

NOTE:

1. The variable P is a pointer which is defined at offset 15h in Table D5.

APPENDIX D ARCHITECTURE BLOCK DIAGRAM

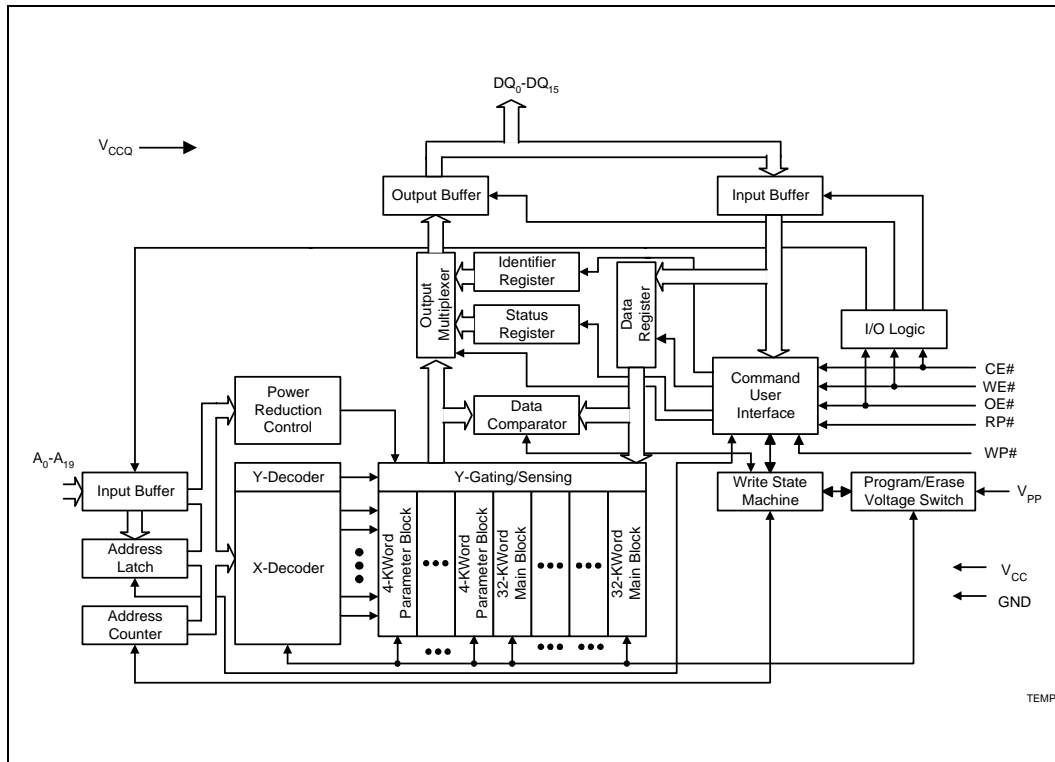



APPENDIX E WORD-WIDE MEMORY MAP DIAGRAMS

8-Mbit, 16-Mbit, and 32-Mbit Word-Wide Memory Addressing

Top Boot				Bottom Boot			
Size (KW)	8M	16M	32M	Size (KW)	8M	16M	32M
4	7F000-7FFFF	FF000-FFFFF	1FF000-1FFFFF	32			1F8000-1FFFFF
4	7E000-7EFFF	FE000-FEFFF	1FE000-1FEFFF	32			1F0000-1F7FFF
4	7D000-7DFFF	FD000-FDFFF	1FD000-1FDFFF	32			1E8000-1EFFFF
4	7C000-7CFFF	FC000-FCFFF	1FC000-1FCFFF	32			1E0000-1E7FFF
4	7B000-7BFFF	FB000-FBFFF	1FB000-1FBFFF	32			1D8000-1DFFFF
4	7A000-7AFFF	FA000-FAFFF	1FA000-1FAFFF	32			1D0000-1D7FFF
4	79000-79FFF	F9000-F9FFF	1F9000-1F9FFF	32			1C8000-1CFFFF
4	78000-78FFF	F8000-F8FFF	1F8000-1F8FFF	32			1C0000-1C7FFF
32	70000-77FFF	F0000-F7FFF	1F0000-1F7FFF	32			1B8000-1BFFFF
32	68000-6FFFF	E8000-EFFFF	1E8000-1EFFFF	32			1B0000-1B7FFF
32	60000-67FFF	E0000-E7FFF	1E0000-1E7FFF	32			1A8000-1AFFFF
32	58000-5FFFF	D8000-DFFFF	1D8000-1DFFFF	32			1A0000-1A7FFF
32	50000-57FFF	D0000-D7FFF	1D0000-1D7FFF	32			198000-19FFFF
32	48000-4FFFF	C8000-CFFFF	1C8000-1CFFFF	32			190000-197FFF
32	40000-47FFF	C0000-C7FFF	1C0000-1C7FFF	32			188000-18FFFF
32	38000-37FFF	B8000-BFFFF	1B8000-1BFFFF	32			180000-187FFF
32	30000-37FFF	B0000-B7FFF	1B0000-1B7FFF	32			178000-17FFFF
32	28000-2FFFF	A8000-AFFFF	1A8000-1AFFFF	32			170000-177FFF
32	20000-27FFF	A0000-A7FFF	1A0000-1A7FFF	32			168000-16FFFF
32	18000-1FFFF	98000-9FFFF	198000-19FFFF	32			160000-167FFF
32	10000-17FFF	90000-97FFF	190000-197FFF	32			158000-15FFFF
32	08000-0FFFF	88000-8FFFF	188000-18FFFF	32			150000-157FFF
32	00000-07FFF	80000-87FFF	180000-187FFF	32			148000-14FFFF
32		78000-7FFFF	178000-17FFFF	32			140000-147FFF
32		70000-77FFF	170000-177FFF	32			138000-13FFFF
32		68000-6FFFF	168000-16FFFF	32			130000-137FFF
32		60000-67FFF	160000-167FFF	32			128000-12FFFF
32		58000-5FFFF	158000-15FFFF	32			120000-127FFF
32		50000-57FFF	150000-157FFF	32			118000-11FFFF
32		48000-4FFFF	148000-14FFFF	32			110000-117FFF
32		40000-47FFF	140000-147FFF	32			108000-10FFFF
32		38000-3FFFF	138000-13FFFF	32			100000-107FFF
32		30000-37FFF	130000-137FFF	32		F8000-FFFFF	0F8000-0FFFFF
32		28000-2FFFF	128000-12FFFF	32		F0000-F7FFF	0F0000-0F7FFF
32		20000-27FFF	120000-127FFF	32		E8000-EFFFF	0E8000-0EFFFF
32		18000-1FFFF	118000-11FFFF	32		E0000-E7FFF	0E0000-0E7FFF
32		10000-17FFF	110000-117FFF	32		D8000-DFFFF	0D8000-0DFFFF
32		08000-0FFFF	108000-10FFFF	32		D0000-D7FFF	0D0000-0D7FFF
32		00000-07FFF	100000-107FFF	32		C8000-CFFFF	0C8000-0CFFFF

8-Mbit, 16-Mbit, and 32-Mbit Word-Wide Memory Addressing (Continued)

Top Boot				Bottom Boot			
Size (KW)	8M	16M	32M	Size (KW)	8M	16M	32M
32			0F8000-0FFFFF	32		C0000-C7FFF	0C0000-0C7FFF
32			0F0000-0F7FFF	32		B8000-BFFFF	0B8000-0BFFFF
32			0E8000-0EFFFF	32		B0000-B7FFF	0B0000-0B7FFF
32			0E0000-0E7FFF	32		A8000-AFFFF	0A8000-0AFFFF
32			0D8000-0DFFFF	32		A0000-A7FFF	0A0000-0A7FFF
32			0D0000-0D7FFF	32		98000-9FFFF	098000-09FFFF
32			0C8000-0CFFFF	32		90000-97FFF	090000-097FFF
32			0C0000-0C7FFF	32		88000-8FFFF	088000-08FFFF
32			0B8000-0BFFFF	32		80000-87FFF	080000-087FFF
32			0B0000-0B7FFF	32	78000-7FFFF	78000-7FFFF	78000-7FFFF
32			0A8000-0AFFFF	32	70000-77FFF	70000-77FFF	70000-77FFF
32			0A0000-0A7FFF	32	68000-6FFFF	68000-6FFFF	68000-6FFFF
32			098000-09FFFF	32	60000-67FFF	60000-67FFF	60000-67FFF
32			090000-097FFF	32	58000-5FFFF	58000-5FFFF	58000-5FFFF
32			088000-08FFFF	32	50000-57FFF	50000-57FFF	50000-57FFF
32			080000-087FFF	32	48000-4FFFF	48000-4FFFF	48000-4FFFF
32			078000-077FFF	32	40000-47FFF	40000-47FFF	40000-47FFF
32			070000-077FFF	32	38000-3FFFF	38000-3FFFF	38000-3FFFF
32			068000-06FFFF	32	30000-37FFF	30000-37FFF	30000-37FFF
32			060000-067FFF	32	28000-2FFFF	28000-2FFFF	28000-2FFFF
32			058000-05FFFF	32	20000-27FFF	20000-27FFF	20000-27FFF
32			050000-057FFF	32	18000-1FFFF	18000-1FFFF	18000-1FFFF
32			048000-04FFFF	32	10000-17FFF	10000-17FFF	10000-17FFF
32			040000-047FFF	32	08000-0FFFF	08000-0FFFF	08000-0FFFF
32			038000-03FFFF	4	07000-07FFF	07000-07FFF	07000-07FFF
32			030000-037FFF	4	06000-06FFF	06000-06FFF	06000-06FFF
32			028000-02FFFF	4	05000-05FFF	05000-05FFF	05000-05FFF
32			020000-027FFF	4	04000-04FFF	04000-04FFF	04000-04FFF
32			018000-01FFFF	4	03000-03FFF	03000-03FFF	03000-03FFF
32			010000-017FFF	4	02000-02FFF	02000-02FFF	02000-02FFF
32			008000-00FFFF	4	01000-01FFF	01000-01FFF	01000-01FFF
32			000000-007FFF	4	00000-00FFF	00000-00FFF	00000-00FFF

APPENDIX F BYTE-WIDE MEMORY MAP DIAGRAMS

Byte-Wide Memory Addressing

Top Boot				Bottom Boot			
Size (KB)	8M	16M	32M	Size (KB)	8M	16M	32M
8	FE000-FFFFF	1FE000-1FFFFF	3FE000-3FFFFFF	64			3F0000-3FFFFFF
8	FC000-FDFFF	1FC000-1FDFFF	3FC000-3FDFFF	64			3E0000-3FFFFFF
8	FA000-FBFFF	1FA000-1FBFFF	3FA000-3FBFFF	64			3D0000-3FFFFFF
8	F8000-F9FFF	1F8000-1F9FFF	3F8000-3F9FFF	64			3C0000-3FFFFFF
8	F6000-F7FFF	1F6000-1F7FFF	3F6000-3F7FFF	64			3B0000-3FFFFFF
8	F4000-F5FFF	1F4000-1F5FFF	3F4000-3F5FFF	64			3A0000-3FFFFFF
8	F2000-F3FFF	1F2000-1F3FFF	3F2000-3F3FFF	64			390000-3FFFFFF
8	F0000-F1FFF	1F0000-1F1FFF	3F0000-3F1FFF	64			380000-3FFFFFF
64	E0000-EFFFF	1E0000-1EFFFF	3E0000-3EFFFF	64			370000-37FFFF
64	D0000-DFFFF	1D0000-1DFFFF	3D0000-3DFFFF	64			360000-36FFFF
64	C0000-CFFFF	1C0000-1CFFFF	3C0000-3CFFFF	64			350000-35FFFF
64	B0000-BFFFF	1B0000-1BFFFF	3B0000-3BFFFF	64			340000-34FFFF
64	A0000-AFFFF	1A0000-1AFFFF	3A0000-3AFFFF	64			330000-33FFFF
64	90000-9FFFF	190000-19FFFF	390000-39FFFF	64			320000-32FFFF
64	80000-8FFFF	180000-18FFFF	380000-38FFFF	64			310000-31FFFF
64	70000-7FFFF	170000-17FFFF	370000-37FFFF	64			300000-30FFFF
64	60000-6FFFF	160000-16FFFF	360000-36FFFF	64			2F0000-2FFFFF
64	50000-5FFFF	150000-15FFFF	350000-35FFFF	64			2E0000-2EFFFF
64	40000-4FFFF	140000-14FFFF	340000-34FFFF	64			2D0000-2DFFFF
64	30000-3FFFF	130000-13FFFF	330000-33FFFF	64			2C0000-2CFFFF
64	20000-2FFFF	120000-12FFFF	320000-32FFFF	64			2B0000-2BFFFF
64	10000-1FFFF	110000-11FFFF	310000-31FFFF	64			2A0000-2AFFFF
64	00000-0FFFF	100000-10FFFF	300000-30FFFF	64			290000-29FFFF
64		0F0000-0FFFFF	2F0000-2FFFFF	64			280000-28FFFF
64		0E0000-0EFFFF	2E0000-2EFFFF	64			270000-27FFFF
64		0D0000-0DFFFF	2D0000-2DFFFF	64			260000-26FFFF
64		0C0000-0CFFFF	2C0000-2CFFFF	64			250000-25FFFF
64		0B0000-0BFFFF	2B0000-2BFFFF	64			240000-24FFFF
64		0A0000-0AFFFF	2A0000-2AFFFF	64			230000-23FFFF
64		090000-09FFFF	290000-29FFFF	64			220000-22FFFF
64		080000-08FFFF	280000-28FFFF	64			210000-21FFFF
64		070000-07FFFF	270000-27FFFF	64			200000-20FFFF
64		060000-06FFFF	260000-26FFFF	64		1F0000-1FFFFF	1F0000-1FFFFF
64		050000-05FFFF	250000-25FFFF	64		1E0000-1EFFFF	1E0000-1EFFFF
64		040000-04FFFF	240000-24FFFF	64		1D0000-1DFFFF	1D0000-1DFFFF
64		030000-03FFFF	230000-23FFFF	64		1C0000-1CFFFF	1C0000-1CFFFF
64		020000-02FFFF	220000-22FFFF	64		1B0000-1BFFFF	1B0000-1BFFFF
64		010000-01FFFF	210000-21FFFF	64		1A0000-1AFFFF	1A0000-1AFFFF
64		000000-00FFFF	200000-20FFFF	64		190000-19FFFF	190000-19FFFF

Byte-Wide Memory Addressing (Continued)

Top Boot				Bottom Boot			
Size (KB)	8M	16M	32M	Size (KB)	8M	16M	32M
64			1F0000-1FFFFF	64		180000-18FFFF	180000-18FFFF
64			1E0000-1EFFFF	64		170000-17FFFF	170000-17FFFF
64			1D0000-1DFFFF	64		160000-16FFFF	160000-16FFFF
64			1C0000-1CFFFF	64		150000-15FFFF	150000-15FFFF
64			1B0000-1BFFFF	64		140000-14FFFF	140000-14FFFF
64			1A0000-1AFFFF	64		130000-13FFFF	130000-13FFFF
64			190000-19FFFF	64		120000-12FFFF	120000-12FFFF
64			180000-18FFFF	64		110000-11FFFF	110000-11FFFF
64			170000-17FFFF	64		100000-10FFFF	100000-10FFFF
64			160000-16FFFF	64	F0000-FFFFF	0F0000-0FFFFF	0F0000-0FFFFF
64			150000-15FFFF	64	E0000-EFFFF	0E0000-0EFFFF	0E0000-0EFFFF
64			140000-14FFFF	64	D0000-DFFFF	0D0000-0DFFFF	0D0000-0DFFFF
64			130000-13FFFF	64	C0000-CFFFF	0C0000-0CFFFF	0C0000-0CFFFF
64			120000-12FFFF	64	B0000-BFFFF	0B0000-0BFFFF	0B0000-0BFFFF
64			110000-11FFFF	64	A0000-AFFFF	0A0000-0AFFFF	0A0000-0AFFFF
64			100000-10FFFF	64	90000-9FFFF	090000-09FFFF	090000-09FFFF
64			0F0000-0FFFFF	64	80000-8FFFF	080000-08FFFF	080000-08FFFF
64			0E0000-0EFFFF	64	70000-7FFFF	070000-07FFFF	070000-07FFFF
64			0D0000-0DFFFF	64	60000-6FFFF	060000-06FFFF	060000-06FFFF
64			0C0000-0CFFFF	64	50000-5FFFF	050000-05FFFF	050000-05FFFF
64			0B0000-0BFFFF	64	40000-4FFFF	040000-04FFFF	040000-04FFFF
64			0A0000-0AFFFF	64	30000-3FFFF	030000-03FFFF	030000-03FFFF
64			090000-09FFFF	64	20000-2FFFF	020000-02FFFF	020000-02FFFF
64			080000-08FFFF	64	10000-1FFFF	010000-01FFFF	010000-01FFFF
64			070000-07FFFF	8	0E000-0FFFF	00E000-00FFFF	00E000-00FFFF
64			060000-06FFFF	8	0C000-0DFFF	00C000-00DFFF	00C000-00DFFF
64			050000-05FFFF	8	0A000-0BFFF	00A000-00BFFF	00A000-00BFFF
64			040000-04FFFF	8	08000-09FFF	008000-009FFF	008000-009FFF
64			030000-03FFFF	8	06000-07FFF	006000-007FFF	006000-007FFF
64			020000-02FFFF	8	04000-05FFF	004000-005FFF	004000-005FFF
64			010000-01FFFF	8	02000-03FFF	002000-003FFF	002000-003FFF
64			000000-00FFFF	8	00000-01FFF	000000-001FFF	000000-001FFF

APPENDIX G DEVICE ID TABLE

Read Configuration Addresses and Data

Item		Address	Data
Manufacturer Code	x16	00000	0089
	x8	00000	89
Device Code			
8-Mbit x 16-T	x16	00001	88C0
8-Mbit x 16-B	x16	00001	88C1
16-Mbit x 16-T	x16	00001	88C2
16-Mbit x 16-B	x16	00001	88C3
32-Mbit x 16-T	x16	00001	88C4
32-Mbit x 16-B	x16	00001	88C5
8-Mbit x 8-T	x8	00001	C0
8-Mbit x 8-B	x8	00001	C1
16-Mbit x 8-T	x8	00001	C2
16-Mbit x 8-B	x8	00001	C3
32-Mbit x 8-T	x8	00001	C4
32-Mbit x 8-B	x8	00001	C5

NOTE: Other locations within the configuration address space are reserved by Intel for future use.

APPENDIX H PROTECTION REGISTER ADDRESSING

Word-Wide Protection Register Addressing

Word	Use	A7	A6	A5	A4	A3	A2	A1	A0
LOCK	Both	1	0	0	0	0	0	0	0
0	Factory	1	0	0	0	0	0	0	1
1	Factory	1	0	0	0	0	0	1	0
2	Factory	1	0	0	0	0	0	1	1
3	Factory	1	0	0	0	0	1	0	0
4	User	1	0	0	0	0	1	0	1
5	User	1	0	0	0	0	1	1	0
6	User	1	0	0	0	0	1	1	1
7	User	1	0	0	0	1	0	0	0

Byte-Wide Protection Register Addressing

Byte	Use	A11	A7	A6	A5	A4	A3	A2	A1	A0
LOCK	Both	0	1	0	0	0	0	0	0	0
0	Factory	0	1	0	0	0	0	0	0	1
1	Factory	1	1	0	0	0	0	0	0	1
2	Factory	0	1	0	0	0	0	0	1	0
3	Factory	1	1	0	0	0	0	0	1	0
4	Factory	0	1	0	0	0	0	0	1	1
5	Factory	1	1	0	0	0	0	0	1	1
6	Factory	0	1	0	0	0	0	1	0	0
7	Factory	1	1	0	0	0	0	1	0	0
8	User	0	1	0	0	0	0	1	0	1
9	User	1	1	0	0	0	0	1	0	1
10	User	0	1	0	0	0	0	1	1	0
11	User	1	1	0	0	0	0	1	1	0
12	User	0	1	0	0	0	0	1	1	1
13	User	1	1	0	0	0	0	1	1	1
14	User	0	1	0	0	0	1	0	0	0
15	User	1	1	0	0	0	0	0	0	0