

CLASSIFICATION Einstufung	PRODUCT SPECIFICATION Produktspezifikation	No. DS-4555-2400-102	REV. A
SUBJECT Thema	MODEM FOR IEEE802.15.4 (ZIGBEE) "ZigBee" Modem" (IEEE802.15.4)	PAGE Seite	2 of 26
CUSTOMER'S CODE PAN4555	PANASONIC'S CODE ENWC9A0xxxEF	DATE Datum	26.04.2007

TABLE OF CONTENTS

1.	Key Features	4
2.	Applications for the Module	4
3.	Description of the Module.....	5
4.	Scope of this Document	5
5.	History for this Document	5
6.	Terminal Layout.....	6
7.	Block Diagram	8
8.	Key Parts List	8
9.	Test Conditions	8
10.	Absolute Maximum Ratings.....	9
11.	Operating Conditions.....	9
12.	DC Electrical Characteristics.....	10
13.	A/D converter Characteristics.....	10
14.	AC Electrical Characteristics	11
15.	Soldering Temperature-Time Profile (for reflow soldering)	12
	15.1. For lead solder	12
	15.2. For leadfree solder.....	12
16.	Module Dimension.....	13
17.	Foot Print of the Module	13
18.	Labeling Drawing.....	14
19.	Mechanical Requirements.....	14
20.	Recommended Land Pattern	15
21.	Development of Applications with freescale BeeStack™	16
22.	Reliability Tests	17
23.	Cautions	17
	23.1. Notes of design	17
	23.2. Notes of installation.....	18
	23.3. Notes of usage conditions.....	18
	23.4. Notes of storage.....	19
	23.5. Cautions for safety	19
	23.6. Other cautions.....	19
24.	Packaging.....	21
	24.1. Tape Dimension.....	21
	24.2. Packing in Tape	21
	24.3. Component direction.....	22
	24.4. Reel Dimension.....	22
	24.5. Label for Package	23
	24.6. Total Packing Handling	23

HIGH FREQUENCY PRODUCTS DIVISION
Module Business
PANASONIC ELECTRONIC DEVICES
EUROPE GmbH

APPROVED
genehmigt

CHECKED
geprüft

DESIGNED
erstellt

CLASSIFICATION Einstufung	PRODUCT SPECIFICATION Produktspezifikation	No. DS-4555-2400-102	REV. A
SUBJECT Thema	MODEM FOR IEEE802.15.4 (ZIGBEE) "ZigBee" Modem" (IEEE802.15.4)	PAGE Seite	3 of 26
CUSTOMER'S CODE PAN4555	PANASONIC'S CODE ENWC9A0xxxEF	DATE Datum	26.04.2007

24.7. Cover tape reel strength	24
25. Ordering Information	24
26. RoHS Declaration.....	25
27. Data Sheet Status	25
28. Related Documents.....	25
29. General Information.....	26
30. Life Support Policy	26

PRELIMINARY

HIGH FREQUENCY PRODUCTS DIVISION Module Business PANASONIC ELECTRONIC DEVICES EUROPE GmbH	APPROVED genehmigt	CHECKED geprüft	DESIGNED erstellt
			www.DataSheet4U.com

CLASSIFICATION Einstufung	PRODUCT SPECIFICATION Produktspezifikation	No. DS-4555-2400-102	REV. A
SUBJECT Thema	MODEM FOR IEEE802.15.4 (ZIGBEE) "ZigBee" Modem" (IEEE802.15.4)	PAGE Seite	4 of 26
CUSTOMER'S CODE PAN4555	PANASONIC'S CODE ENWC9A0xxxEF	DATE Datum	26.04.2007

1. KEY FEATURES

Schlüsseleigenschaften

- Short range 2,4GHz ISM band transceiver with microcontroller and reference oscillator
- Provides complete hardware for a wireless node using IEEE802.15.4 packet structure
- Very small size (12.2mm x 16.4mm x 2.2mm)
- 2 antenna options: Single port 50Ω or ceramic antenna
- 16 selectable Channels with 250 kbps in the 2.4 GHz band
- Low power modes for increased battery life
- High sensitivity of -92 dBm typ. at 1% Packet Error Rate
- 0 dBm typ. output power programmable over a 30 dB range
- Low supply voltage (2.0 V to 3.4 V, 2.7 V typ.)
- Operating temperature range -40°C to +85°C
- Link Quality and Clear Channel Assessment capability
- 60k Flash and 4k RAM memory
- 4 channel A/D converter with 10 Bit for fast and easy conversion from analog inputs -such as temperature, pressure and fluid levels- to digital values.
- 3 channel 16 Bit timer/pulse width modulation (TPM) outputs
- BDM port for direct download programming
- In total 20 digital I/O lines with programmable pull-ups and few with high-current driver.
- Low power modes for increased battery life
- Low battery warning
- Low voltage detect/reset
- Complies with ETSI EN300328 and FCC Part 15B

2. APPLICATIONS FOR THE MODULE

Anwendungen für das Modul

- ZigBee™ FFD (full functional) and RFD (reduced functional) devices working in star and mesh networks
- Wireless sensor and actuator networks
- Remote control and wire replacement in industrial systems
- Factory and home automation and control
- Inventory and logistics management
- HID (Human Interface Devices)
- Toys
- Home gateways
- proprietary networking solutions using IEEE802.15.4

HIGH FREQUENCY PRODUCTS DIVISION
Module Business
PANASONIC ELECTRONIC DEVICES
EUROPE GmbH

APPROVED
genehmigt

CHECKED
geprüft

DESIGNED
erstellt

CLASSIFICATION Einstufung	PRODUCT SPECIFICATION Produktspezifikation	No. DS-4555-2400-102	REV. A
SUBJECT Thema	MODEM FOR IEEE802.15.4 (ZIGBEE) "ZigBee" Modem" (IEEE802.15.4)	PAGE Seite	5 of 26
CUSTOMER'S CODE PAN4555	PANASONIC'S CODE ENWC9A0xxxEF	DATE Datum	26.04.2007

3. DESCRIPTION OF THE MODULE

Beschreibung des Moduls

The PAN4555 module is a short range, low power, 2.4 GHz ISM band transceiver which includes a complete 802.15.4 physical layer (PHY) modem, designed for the IEEE 802.15.4 wireless standard and a appropriate microcontroller (MCU) with reference oscillator which provides a cost effective solution for short-range data links and networks.

The main purpose of PAN4555 are ZigBee™ (www.zigbee.org) applications based on "BeeStack" of Freescale Inc.. For details on ZigBee™ application software see chapter 21.

Proprietary networking solutions on top of the IEEE802.15.4 MAC/PHY software package (available at www.freescale.com/zigbee) could be implemented instead of ZigBee™ as well.

As Integrated Development Environment (IDE) the Metrowerks™ CodeWarrior IDE from www.metrowerks.com is required. For device flash programming via the BDM port of PAN4555 the USB HCS08/HCS12 Multilink from www.pemicro.com is recommended.

4. SCOPE OF THIS DOCUMENT

Umfang dieses Dokumentes

This product specification applies to the ZigBee ready modem ENWC9A0xxxE.
The xxx is the indicator for different versions (refer to chapter 25 Ordering Information).
The used ZigBee chip is the MC13194 from the US company freescale
www.freescale.com/zigbee

Diese Produktionsunterlagen beziehen sich auf das ZigBee ready Modem ENWC9A0xxxE
Die Zeichen xxx bezeichnen verschiedene Versionen (Erklärung im Kapitel 25 Ordering Information).

Der verwendete ZigBee Chip ist der MC13194 der US Firma freescale.

5. HISTORY FOR THIS DOCUMENT

Versionsverwaltung dieses Dokumentes

Revision Version	Date Datum	Modification / Remarks Änderungen / Bemerkungen
A	26.04.2007	Initial draft version

HIGH FREQUENCY PRODUCTS DIVISION
Module Business
PANASONIC ELECTRONIC DEVICES
EUROPE GmbH

APPROVED
genehmigt

CHECKED
geprüft

DESIGNED
erstellt

CLASSIFICATION Einstufung	PRODUCT SPECIFICATION Produktspezifikation	No. DS-4555-2400-102	REV. A
SUBJECT Thema	MODEM FOR IEEE802.15.4 (ZIGBEE) "ZigBee" Modem" (IEEE802.15.4)	PAGE Seite	6 of 26
CUSTOMER'S CODE PAN4555	PANASONIC'S CODE ENWC9A0xxxEF	DATE Datum	26.04.2007

6. TERMINAL LAYOUT Anschlußbelegung

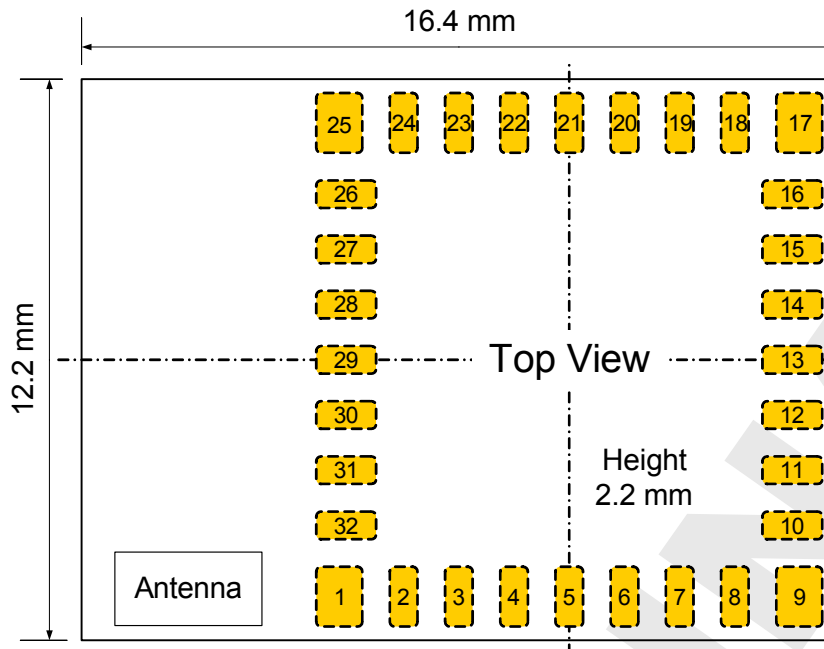

Please refer also to the MC1321x technical data sheet and reference manual, which is given in [2] and [3] in chapter Related Documents.

Pin No.	Pin Name	Pin Type	Description
1	GND	I/O	Ground
2	PTB0 / AD1P0	I/O	MCU Port B Bit 0 / ATD analog Channel 0
3	PTB1 / AD1P1	I/O	MCU Port B Bit 1 / ATD analog Channel 1
4	PTB2 / AD1P2	I/O	MCU Port B Bit 2 / ATD analog Channel 2
5	PTB7/AD1P7	I/O	MCU Port B Bit 7 / ATD analog Channel 7
6	VREFH	I	MCU high reference voltage for ATD
7	PTA7 / KBI1P7	Dig. I/O	MCU Port A Bit 7 / Keyboard Input Bit 7
8	PTA5 / KBI1P5	Dig. I/O	MCU Port A Bit 5 / Keyboard Input Bit 5
9	GND	I/O	Ground
10	PTA6 / KBI1P6	Dig. I/O	MCU Port A Bit 6 / Keyboard Input Bit 6
11	PTG0 / BKGND / MS	Dig. I/O	MCU Port G Bit 0 / Background / Mode Select ⁽¹⁾
12	PTG1 / XTAL	Dig. I/O / O	MCU Port G Bit 1 / Crystal oscillator output ⁽²⁾
13	PTG2 / EXTAL	Dig. I/O / I	MCU Port G Bit 2 / Crystal oscillator input ⁽²⁾
14	GND	I/O	Ground

HIGH FREQUENCY PRODUCTS DIVISION
Module Business
PANASONIC ELECTRONIC DEVICES
EUROPE GmbH

APPROVED
genehmigt

CHECKED
geprüft

DESIGNED
erstellt

CLASSIFICATION Einstufung	PRODUCT SPECIFICATION Produktspezifikation	No. DS-4555-2400-102	REV. A
SUBJECT Thema	MODEM FOR IEEE802.15.4 (ZIGBEE) "ZigBee" Modem" (IEEE802.15.4)	PAGE Seite 7 of 26	
CUSTOMER'S CODE PAN4555	PANASONIC'S CODE ENWC9A0xxxEF	DATE Datum 26.04.2007	

Pin No.	Pin Name	Pin Type	Description
15	PTC0 / TXD2	Dig. I/O	MCU Port C Bit 0 / SCI2 TX data out
16	PTC1 / RXD2	Dig. I/O	MCU Port C Bit 1/ SCI2 RX data in
17	GND	I/O	Ground
18	PTC5	Dig. I/O	MCU Port C Bit 5
19	PTC3 / SCL1	Dig. I/O	MCU Port C Bit 1/ IIC bus clock
20	PTC2 / SDA1	Dig. I/O	MCU Port C Bit 1/ IIC bus clock
21	PTE0 / TXD1	Dig. I/O	MCU Port E Bit 0 / SCI1 TX data out
22	PTE1 / RXD1	Dig. I/O	MCU Port E Bit 1/ SCI1 RX data in
23	VDDA	Power O	Modem analog regulated supply output
24	Vcc	Power I	Modem voltage regulators' input
25	GND	I/O	Ground
26	Vcc	Power I	Modem voltage regulators' input
27	 RESET	Dig. I/O	MCU reset. Active low
28	PTD6 / TPM2CH3	Dig. I/O	MCU Port D Bit 6 / TPM2 Channel 3
29	PTD4 / TPM2CH1	Dig. I/O	MCU Port D Bit 4 / TPM2 Channel 1
30	PTD2 / TPM1CH2	Dig. I/O	MCU Port D Bit 2 / TPM1 Channel 2
31	GND	I/O	Ground
32	EXANT	I/O	Pin for external antenna (50 Ω)

Note:

- (1) PTG0 is output only. Pin is I/O when used as BDM function.
- (2) Full I/O when not used as clock source. Please refer also to [2].

HIGH FREQUENCY PRODUCTS DIVISION
Module Business
PANASONIC ELECTRONIC DEVICES
EUROPE GmbH

APPROVED
genehmigt

CHECKED
geprüft

DESIGNED
erstellt

CLASSIFICATION Einstufung	PRODUCT SPECIFICATION Produktspezifikation	No. DS-4555-2400-102	REV. A
SUBJECT Thema	MODEM FOR IEEE802.15.4 (ZIGBEE) "ZigBee" Modem" (IEEE802.15.4)	PAGE Seite	8 of 26
CUSTOMER'S CODE PAN4555	PANASONIC'S CODE ENWC9A0xxxEF	DATE Datum	26.04.2007

7. BLOCK DIAGRAM Blockdiagramm

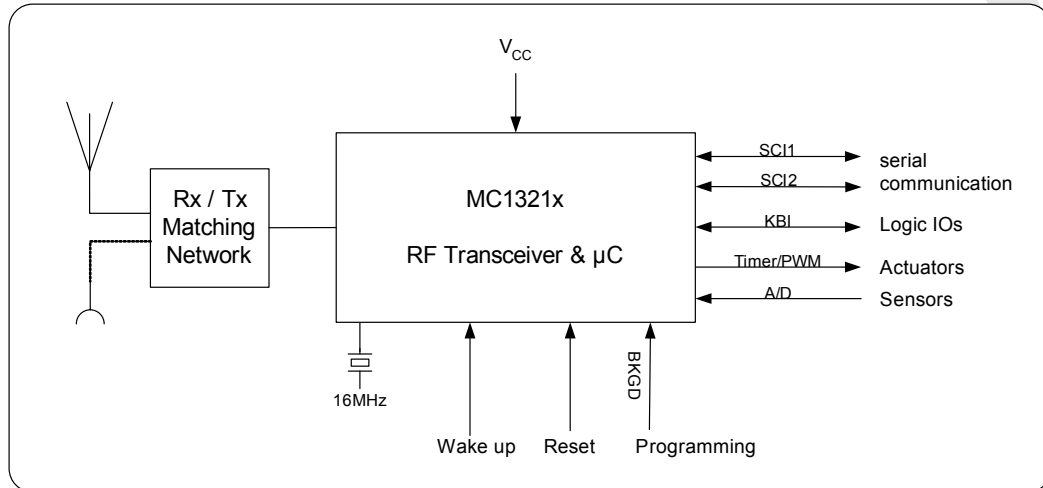

8. KEY PARTS LIST Liste der Schlüsselkomponenten

Part Name Teilenummer	Material Material
P.W.Board Leiterplatte	Glass cloth epoxide resin with gold plating FR4 mit Goldauflage
Casing Deckel	Material: BZn15-20, thickness 0.15mm Material: Weißblech 0,15mm Dicke
IC part name IC Name	MC13194 (freescale www.freescale.com/zigbee) All information are based on [2] chapter 28

9. TEST CONDITIONS Meßbedingungen

Measurements shall be made under room temperature and humidity unless otherwise specified.
Messungen unter normalen Bedingungen, Abweichungen sind gesondert notiert.

Temperature	25 ± 10°C	Humidity	40 to 85%RH
Temperatur	25 ± 10°C	Luftfeuchtigkeit	40 to 85%RH

HIGH FREQUENCY PRODUCTS DIVISION
Module Business
PANASONIC ELECTRONIC DEVICES
EUROPE GmbH

APPROVED
genehmigt

CHECKED
geprüft

DESIGNED
erstellt

CLASSIFICATION Einstufung	PRODUCT SPECIFICATION Produktspezifikation	No. DS-4555-2400-102	REV. A
SUBJECT Thema	MODEM FOR IEEE802.15.4 (ZIGBEE) "ZigBee" Modem" (IEEE802.15.4)	PAGE Seite	9 of 26
CUSTOMER'S CODE PAN4555	PANASONIC'S CODE ENWC9A0xxxEF	DATE Datum	26.04.2007

10. ABSOLUTE MAXIMUM RATINGS

Absolute Grenzwerte

The maximum ratings may not be exceeded under any circumstances, not even momentarily and individually, as permanent damage to the module will result.

No.	Item Punkt	Symbol Zeichen	Absolute Maximum Ratings Absolute Grenzwerte	Unit Einheit
1	Supply voltage	V_{CC}	-0.3 to +3.6	Vdc
2	Ripple on V_{CC}	V_{CCrip}	100 (ripple frequency ≥ 200 kHz)	mVpp
3	Digital input voltages	V_{in}	-0.3 to $V_{CC}+0.3$	Vdc
4	Instantaneous maximum current Single pin limit for all digital I/O pins ⁽¹⁾	I_D	± 25	mAdc
5	Storage temperature range	T_{stg}	-40 to +105	$^{\circ}C$
6	Operating temperature range	T_{op}	-40 to +85	$^{\circ}C$
7	RF Input Power	P_{max}	10	dBm
8	ESD on any pin except for pin 32 EXANT. Human Body Model (HBM)	V_{THHBM}	± 2	kV
9	Lead temperature Löttemperatur	T_{Death}	Please refer to chapter 15.2.	$^{\circ}C$
10	Moisture Sensitivity Level	MSL	3 (168 hours)	

Notes:

(1) Input must be current limited to the value specified

11. OPERATING CONDITIONS

Betriebsbedingungen

No.	Item	Condition / Remark	Symbol	Value			Unit
				Min	Typ	Max	
1	Supply voltage	The typical value is recommended	V_{CC}	2.0	2.7	3.4	Vdc
2	RF Input Frequency		f_{in}	2405		2480	MHz
3	Return loss of load at pin 32 EXANT	Receive/Transmit Mode to 50 Ω reference load	a	-10			dB
4	Logic Input Voltage Low		V_{IL}	0		$0.3 \times V_{CC}$	V
5	Logic Input Voltage High		V_{IH}	$0.7 \times V_{CC}$		V_{CC}	V
6	SPI clock rate	The typical value is recommended	f_{SPI}	-	8.0	8.0	MHz
7	Operating temperature range		T_{op}	-40		+85	$^{\circ}C$

HIGH FREQUENCY PRODUCTS DIVISION
Module Business
PANASONIC ELECTRONIC DEVICES
EUROPE GmbH

APPROVED
genehmigt

CHECKED
geprüft

DESIGNED
erstellt

CLASSIFICATION Einstufung	PRODUCT SPECIFICATION Produktspezifikation	No. DS-4555-2400-102	REV. A
SUBJECT Thema	MODEM FOR IEEE802.15.4 (ZIGBEE) "ZigBee" Modem" (IEEE802.15.4)	PAGE Seite 10 of 26	
CUSTOMER'S CODE PAN4555	PANASONIC'S CODE ENWC9A0xxxEF	DATE Datum 26.04.2007	

12. DC ELECTRICAL CHARACTERISTICS

$V_{CC} = 2.7V$, $T_{amb} = 25^{\circ}C$ if nothing else stated

No.	Item	Condition / Remark	Symbol	Value			Unit
				Min	Typ	Max	
1	Transmit current consumption	Transmit Mode ⁽¹⁾	I_{CCT}		30	35	mA
2	Receive current consumption	Receive Mode	I_{CCR}		37	42	mA
3	Low power current consumption	Off ⁽²⁾	$I_{leakage}$		0.2	1.0	μA
		Hibernate ⁽²⁾	I_{CCH}		1.0	6.0	μA
		Doze (no CLKO) ^{(2) (3)}	I_{CCD}		35	102	μA
		Idle	I_{CCI}		500	800	μA
4	digital I/O pin characteristics	Please refer to [2] 6.3.1 MCU DC Characteristics					
5	digital I/O pin input capacitance	all non-supply pins ⁽⁴⁾	C_{in}			7	pF
6	Low voltage warning/detection Power on reset re-arm voltage	Please refer to [2] 6.3.1 MCU DC Characteristics					

Notes:

- (1) SPI Register 12 is default value of 0x00BC which sets output power to nominal value
- (2) To attain specified low power current, all GPIO and other digital IO must be handled properly. Detailed description could be found at [2] at section 7.2 Low Power Considerations.
- (3) CLKO frequency at default value of 32.786 kHz.
- (4) This parameter is characterized and not tested on each device.

13. A/D CONVERTER CHARACTERISTICS

No	Item	Remark
1	ATD characteristics	Please refer to [2] 6.3.3 MCU ATD Characteristics
2	ATD timing/performance characteristics	Please refer to [2] 6.3.3 MCU ATD Characteristics

The A/D high reference voltage VREFH is connected to pin 6 (VREFH)
The A/D low reference voltage VREFL is internally connected to GND.

HIGH FREQUENCY PRODUCTS DIVISION
Module Business
PANASONIC ELECTRONIC DEVICES
EUROPE GmbH

APPROVED
genehmigt

CHECKED
geprüft

DESIGNED
erstellt

CLASSIFICATION Einstufung	PRODUCT SPECIFICATION Produktspezifikation	No. DS-4555-2400-102	REV. A
SUBJECT Thema	MODEM FOR IEEE802.15.4 (ZIGBEE) "ZigBee" Modem" (IEEE802.15.4)	PAGE Seite 11 of 26	
CUSTOMER'S CODE PAN4555	PANASONIC'S CODE ENWC9A0xxxEF	DATE Datum 26.04.2007	

14. AC ELECTRICAL CHARACTERISTICS

$V_{CC} = 2.7V$, $T_{amb} = 25^{\circ}C$, 50Ω load at EXANT, for all channels number 11,12,..., 26 according to [1]

No Nr	Receiver Empfänger	Limit			Unit Einheit
		Min	Typ	Max	
1	Sensitivity for 1% Packet Error Rate (PER), -85dBm required by [1]	-	-92	-87	dBm
2	Saturation (maximum input level)	0	10	-	dBm
3	Adjacent Channel Interference for 1% PER ($\pm 5MHz$; desired signal -82dBm)	0	29	-	dB
4	Alternate Channel Interference for 1% PER ($\pm 10MHz$; desired signal -82dBm)	0	40	-	dB
5	Frequency Error Tolerance	-	-	200	kHz
6	Symbol Rate Error Tolerance	-	-	80	ppm
7	In-band Spurious Emission	-	tbd	-	dBm
8	Spurious Emissions <1GHz	-	tbd	-57	dBm
9	Spurious Emissions >1GHz	-	tbd	-47	dBm

No Nr	Transmitter Sender	Limit			Unit Einheit
		Min	Typ	Max	
1	Maximum Output Power ⁽¹⁾	-3.0	0.0	-	dBm
2	Nominal Output Power ⁽²⁾	-	-4.0	-	dBm
3	Minimum Output Power	-	tbd	-	dBm
4	Error Vector Magnitude (EVM)	-	25	35	%
5	Power Control Range	-	30	-	dB
6	Over the Air Data Rate	-	250	-	kbps
7	2 nd harmonic @ maximum output power	-	-50	-30	dBm
8	3 rd harmonic @ maximum output power	-	-60	-30	dBm
9	Spurious Emissions <1GHz	-	< -40	-36	dBm
10	Spurious Emissions >1GHz	-	< -40	-30	dBm

No Nr	Stand By In Bereitschaft	Limit			Unit Einheit
		Min	Typ	Max	
1	Spurious Emissions <1GHz	-	< -60	-57	dBm
2	Spurious Emissions >1GHz	-	< -50	-47	dBm

Notes:

- (1) SPI Register 12 programmed to 0xFF which sets output power to maximum.
Measured at pin EXANT for the SMD pad version.
- (2) SPI Register 12 programmed to 0xBC which sets output power to nominal.
Measured at pin EXANT for the SMD pad version.

HIGH FREQUENCY PRODUCTS DIVISION Module Business PANASONIC ELECTRONIC DEVICES EUROPE GmbH	APPROVED genehmigt	CHECKED geprüft	DESIGNED erstellt
--	-----------------------	--------------------	----------------------

www.DataSheet4U.com

CLASSIFICATION Einstufung	PRODUCT SPECIFICATION Produktspezifikation	No. DS-4555-2400-102	REV. A
SUBJECT Thema	MODEM FOR IEEE802.15.4 (ZIGBEE) "ZigBee" Modem" (IEEE802.15.4)	PAGE Seite	12 of 26
CUSTOMER'S CODE PAN4555	PANASONIC'S CODE ENWC9A0xxxEF	DATE Datum	26.04.2007

15. SOLDERING TEMPERATURE-TIME PROFILE (FOR REFLOW SOLDERING)
Temperatur-Zeit Profil für die Reflowlötung

15.1. FOR LEAD SOLDER

**Recommended temp. profile
for reflow soldering**

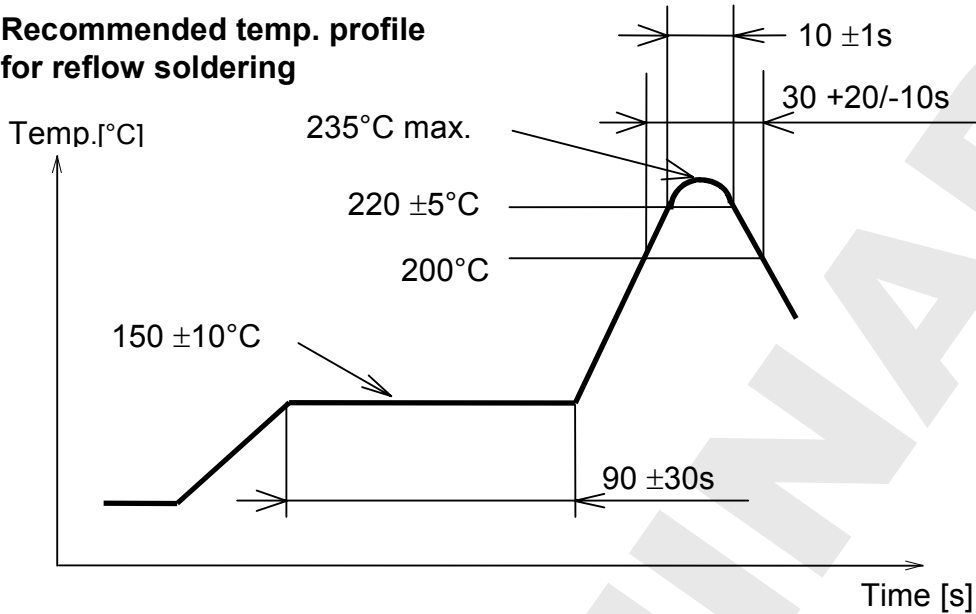

15.2. FOR LEADFREE SOLDER

**Our used temp. profile
for reflow soldering**

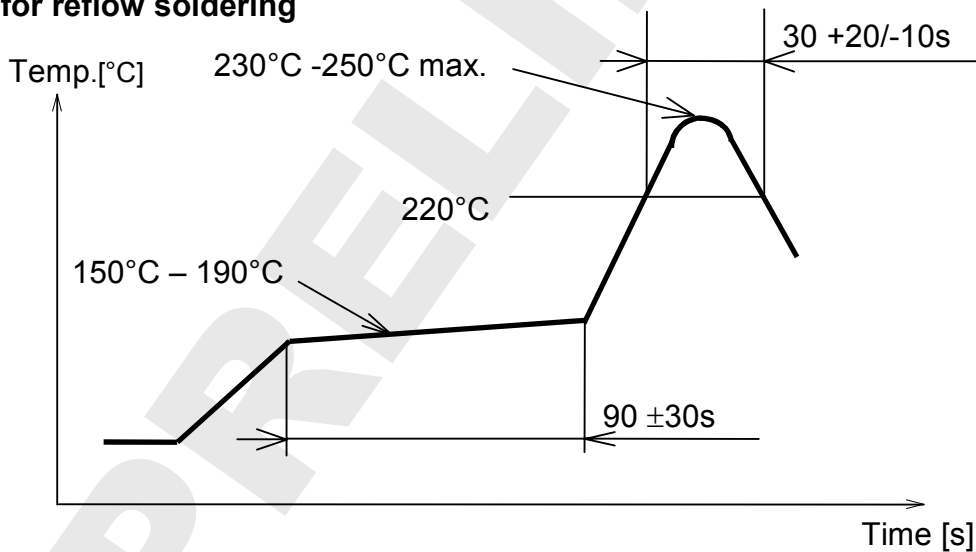

Reflow permissible cycle: 2
Opposite side reflow is prohibited due to module weight.

HIGH FREQUENCY PRODUCTS DIVISION Module Business PANASONIC ELECTRONIC DEVICES EUROPE GmbH	APPROVED genehmigt	CHECKED geprüft	DESIGNED erstellt
--	-----------------------	--------------------	----------------------

CLASSIFICATION Einstufung	PRODUCT SPECIFICATION Produktspezifikation	No. DS-4555-2400-102	REV. A
SUBJECT Thema	MODEM FOR IEEE802.15.4 (ZIGBEE) "ZigBee" Modem" (IEEE802.15.4)	PAGE Seite 13 of 26	
CUSTOMER'S CODE PAN4555	PANASONIC'S CODE ENWC9A0xxxEF	DATE Datum	26.04.2007

16. MODULE DIMENSION Modulabmessungen

No.	Item Punkt	Dimension Abmessung	Tolerance Toleranz	Remark Bemerkung
1	Width	12.20	± 0.20	
2	Lenght	16.40	± 0.20	
3	Height	2.20	± 0.20	With case

17. FOOT PRINT OF THE MODULE Lötpads vom Modul

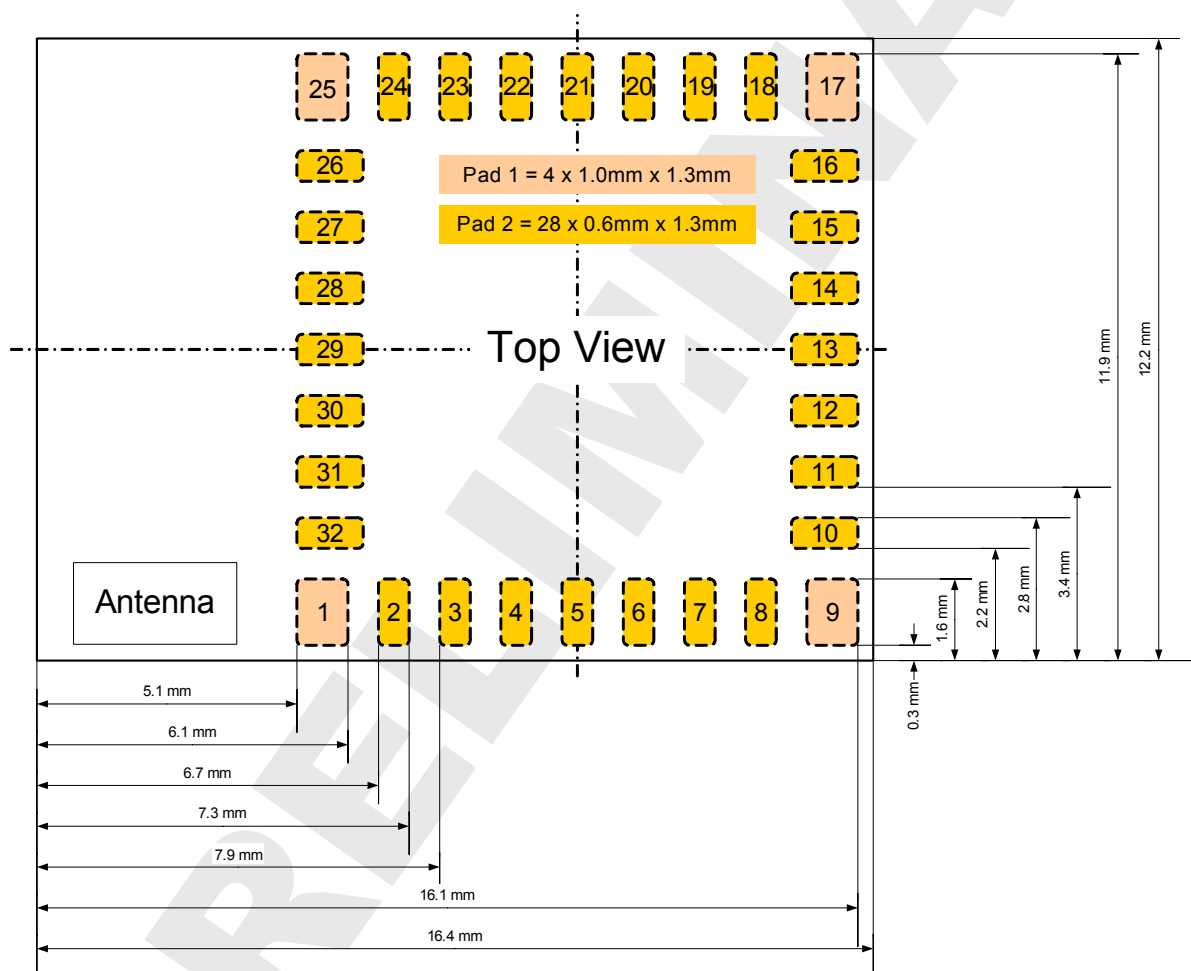

All dimensions in mm.
The outer dimensions has a tolerance of ± 0.2mm.

HIGH FREQUENCY PRODUCTS DIVISION
Module Business
PANASONIC ELECTRONIC DEVICES
EUROPE GmbH

APPROVED
genehmigt

CHECKED
geprüft

DESIGNED
erstellt

CLASSIFICATION Einstufung	PRODUCT SPECIFICATION Produktspezifikation	No. DS-4555-2400-102	REV. A
SUBJECT Thema	MODEM FOR IEEE802.15.4 (ZIGBEE) "ZigBee" Modem" (IEEE802.15.4)	PAGE Seite 14 of 26	
CUSTOMER'S CODE PAN4555	PANASONIC'S CODE ENWC9A0xxxEF	DATE Datum	26.04.2007

18. LABELING DRAWING

Kennzeichnung des Moduls durch Label

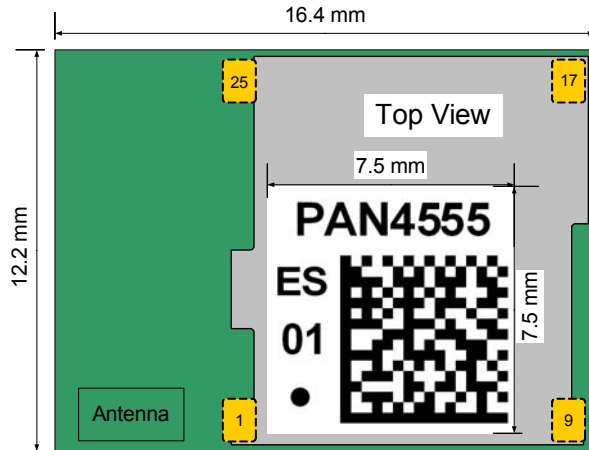

This label is suitable for reflow soldering and designed for the engineering sample status.

Information in the 2D-Barcode are the date code in the format Year-Month-Day [6 signs], serial number [6 signs], ordering number [8 signs; without ENW and F], the identifier for the hardware release [2 signs, now 01] and the ES, separated by a semicolon.

ES stands for Engineering Samples, please refer to chapter General Information.

In mass production status, the ES will be eliminated and replaced by a software identifier. And will be also implemented at the last information in the 2D-Barcode.

The point on the label is the identifier for pin 1 of the module.

01 is the hardware revision.

19. MECHANICAL REQUIREMENTS

Mechanische Anforderungen

No.	Item Punkt	Limit Grenzwerte	Condition Bedingung
1	Solderability Lötbarkeit	More than 75% of the soldering area shall be coated by solder Mehr als 75% der Lötfläche soll mit Lötpaste bedeckt sein.	Reflow soldering with recommendable temperature profile
2	Resistance to soldering heat	It shall be satisfied electrical requirements and not be mechanical damage	Please refer to chapter 15.2.

HIGH FREQUENCY PRODUCTS DIVISION
Module Business
PANASONIC ELECTRONIC DEVICES
EUROPE GmbH

APPROVED
genehmigt

CHECKED
geprüft

DESIGNED
erstellt

CLASSIFICATION Einstufung	PRODUCT SPECIFICATION Produktspezifikation	No. DS-4555-2400-102	REV. A
SUBJECT Thema	MODEM FOR IEEE802.15.4 (ZIGBEE) "ZigBee" Modem" (IEEE802.15.4)	PAGE Seite	15 of 26
CUSTOMER'S CODE PAN4555	PANASONIC'S CODE ENWC9A0xxxEF	DATE Datum	26.04.2007

20. RECOMMENDED LAND PATTERN Empfohlenes Land Pattern

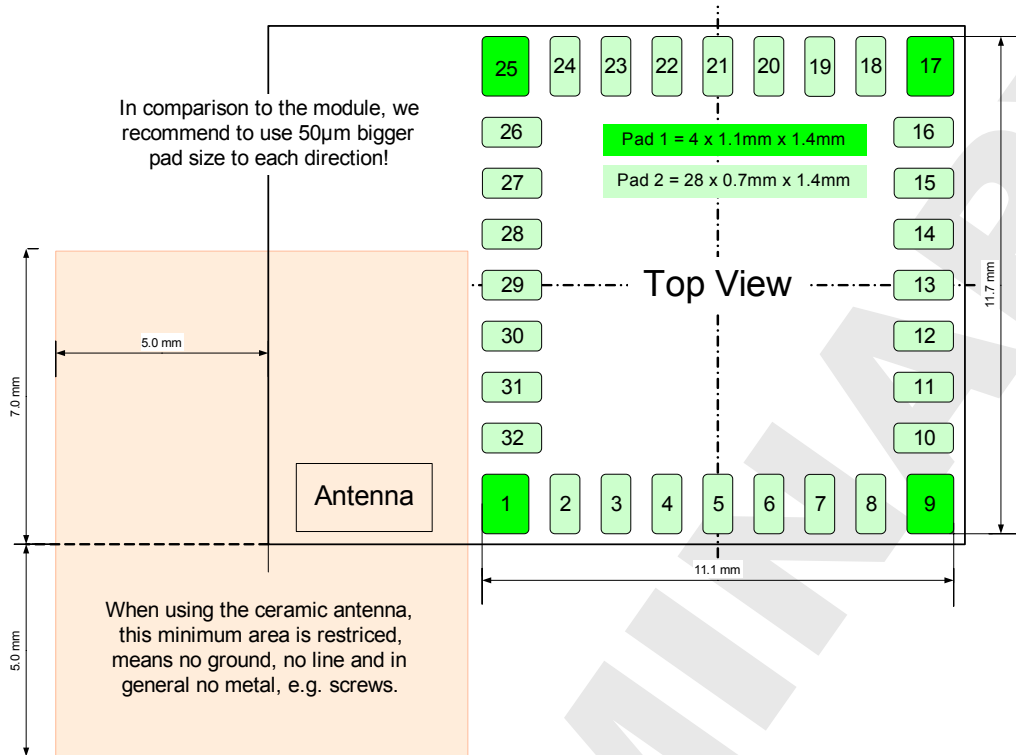

Dimensions in mm.

The land pattern dimensions above can serve as a guidance, but this information is given without any legal responsibility.

For your footprint, we recommend to use 50µm bigger size for the pads at each direction in comparison to the module footprint, please refer to chapter 17. Foot Print of the Module.

For the solder paste screen please use the same as for the module, but slight different measures and shapes of the solder paste screen cutouts might be optimum depending on your soldering process, for example on the chosen solder paste screen thickness. The solder screen thickness depends on your production standard, we recommend 120µm to 150µm.

IMPORTANT:

The bottom side of PAN4555 is fully coated, nevertheless no copper, such as through hole vias, planes or tracks on your board component layer should be located below PAN4555 in order to avoid short cuts. In cases where a track or through hole via has to be located under the module it has to be kept away from PAN4555 bottom pads. The PN4555 multilayer pcb contains an inner RF shielding plane, therefore no pcb shielding plane below the module is needed.

When using the antenna pad version and if your application allows, please place the antenna on the edge of your carrier board.

If you have any questions on these points, we are open to discuss your individual situation.

HIGH FREQUENCY PRODUCTS DIVISION Module Business PANASONIC ELECTRONIC DEVICES EUROPE GmbH	APPROVED genehmigt	CHECKED geprüft	DESIGNED erstellt
--	-----------------------	--------------------	----------------------

CLASSIFICATION Einstufung	PRODUCT SPECIFICATION Produktspezifikation	No. DS-4555-2400-102	REV. A
SUBJECT Thema	MODEM FOR IEEE802.15.4 (ZIGBEE) "ZigBee" Modem" (IEEE802.15.4)	PAGE Seite	16 of 26
CUSTOMER'S CODE PAN4555	PANASONIC'S CODE ENWC9A0xxxEF	DATE Datum	26.04.2007

21. DEVELOPMENT OF APPLICATIONS WITH FREESCALE BEESTACK™

Entwicklung von Applikationen mit Hilfe des BeeStacks von freescale

This chapter are copied from [8], please refer to this document to get more information.

PAN4555 is built around the MC13214 single package from Freescale Inc. which includes the freescale ZigBee codebase BeeStack™ (downscaled versions of PAN4555 with MC1321x suited for IEEE802.15.4 or SMAC only are available on demand as well).

The access to BeeStack™ is provided after registration and login at www.freescale.com/zigbee. After login the BEEKITDOWNLOADPACKAGE.zip can be downloaded. This package contains BeeStack™, IEEE802.15.4 MAC and SMAC codebases. For PAN4555 PHY testing using TestTool™ the download of the latest 1321xEVK package is recommended.

After successful installation of Beekit on a PC open BeeKit. A ZigBee sample solution *.bksln can be created in a few steps.

Important: Before a solution may be exported for PAN4555 the MC1321x target settings have to be changed via the "User defined target editor". The required changes are:

- Uncheck the "Use external Antenna Switch"
- Adjust the port settings depending on your application, the PAN4555 datasheet and for use of the PAN4555 carrier board the pin list in chapter PAN4555 PINLIST at [8].

For importing, compiling and debugging of the BeeKit™ solution the Integrated Development Environment (IDE) Metrowerks™ CodeWarrior from www.metrowerks.com is required.

As device flash programmer the USB HCS08/HCS12 Multilink from www.pemicro.com is recommended.

Important: PAN4555 is a single RF port design with MC13214, refer also to AN3248. The Freescale reference boards 13213-NCB and 13213-SRB are dual port designs, software for these boards will not run.

The shipping of products which use ZigBee™ technology requires a membership of the ZigBee™ Alliance (www.zigbee.org), at least as an adopter member, and is mandatory for the ZigBee™ product certification procedure and use of the ZigBee™ Logo.

The prices and fees as known from today are as follows:

- IDE CodeWarrior order number CWS-H08-C64K-CX from www.metrowerks.com : US\$ 995,-.
- USB HCS08/HCS12 Multilink (www.pemicro.com), orderable at www.freescale.com/zigbee with the ID USBMULTILINKBDM: US\$ 99,-
- BeeStack™: The support fee after a 30 days period free of charge required by Freescale Inc. is US\$ 999,-.

HIGH FREQUENCY PRODUCTS DIVISION Module Business PANASONIC ELECTRONIC DEVICES EUROPE GmbH	APPROVED genehmigt	CHECKED geprüft	DESIGNED erstellt
--	-----------------------	--------------------	----------------------

www.DataSheet4U.com

CLASSIFICATION Einstufung	PRODUCT SPECIFICATION Produktspezifikation	No. DS-4555-2400-102	REV. A
SUBJECT Thema	MODEM FOR IEEE802.15.4 (ZIGBEE) "ZigBee" Modem" (IEEE802.15.4)	PAGE Seite	17 of 26
CUSTOMER'S CODE PAN4555	PANASONIC'S CODE ENWC9A0xxxEF	DATE Datum	26.04.2007

- Companies selling products using ZigBee™ technology have to be a member of the ZigBee™ Alliance (www.zigbee.org). The minimum fee per year for a membership as adopter is US\$ 3500,-.
- For adopter members the fee for listing the first product at (www.zigbee.org) is US\$ 1000,-.
- The cost of a ZigBee™ product certification at a test house (TÜV Rheinland) ranges from approximately US\$ 4000,- to US\$ 8000,-, depending on the implemented software.

22. RELIABILITY TESTS Zuverlässigkeitstests

The measurement should be done after exposed to room temperature and humidity for 1hour.
Die Messungen sollten erst nach einer Stunde Lagerung unter normalen Bedingungen erfolgen.

No.	Item Punkt	Limit Grenzwerte	Condition Bedingung
1	Vibration test	Electrical parameter should be in specification	a) Freq.:10~50Hz,Amplitude:1.5mm a) 20min. / cycle,1hrs. each of XYZ axis b) Freq.:30~100Hz, 6G b) 20min. / cycle,1hrs. each of XYZ axis
2	Shock test	the same as the above	Dropped onto hard wood from height of 50cm for 3 times
3	Heat cycle test	the same as the above	-40°C for 30min. and +85°C for 30min.; each temperature 300 cycles
4	Moisture test	the same as the above	+60°C, 90% RH, 300h
5	Low temp. test	the same as the above	-40°C, 300h
6	High temp. test	the same as the above	+85°C, 300h

23. CAUTIONS Warnungen

Failure to do so may result in degrading of the product's functions and damage to the product.

23.1. NOTES OF DESIGN

Designhinweise

- (1) Please follow the condition written in this specification, especially the control signals of this module.
- (2) This product should not be stressed when installed.
- (3) Heat is the major cause of shortening the life of these products. Please keep this product away from heat.
Avoid assembly and use of the target equipment in conditions where the products' temperature may exceed the maximum allowable.
- (4) The supply voltage should not be exceeding or reverse, and should not carry noise and spike.
- (5) Please keep this product away from other high frequency circuits.

HIGH FREQUENCY PRODUCTS DIVISION Module Business PANASONIC ELECTRONIC DEVICES EUROPE GmbH	APPROVED genehmigt	CHECKED geprüft	DESIGNED erstellt
--	-----------------------	--------------------	----------------------

CLASSIFICATION Einstufung	PRODUCT SPECIFICATION Produktspezifikation	No. DS-4555-2400-102	REV. A
SUBJECT Thema	MODEM FOR IEEE802.15.4 (ZIGBEE) "ZigBee" Modem" (IEEE802.15.4)	PAGE Seite	18 of 26
CUSTOMER'S CODE PAN4555	PANASONIC'S CODE ENWC9A0xxxEF	DATE Datum	26.04.2007

23.2. NOTES OF INSTALLATION

Verarbeitungshinweise

- (1) Reflow soldering is possible for twice on the condition in chapter 15.
Please set up the temperature at the soldering portion of this product according to this reflow profile.
- (2) Carefully position the products so that their heat will not burn into printed circuit boards or affect the other components that are susceptible to heat.
- (3) Carefully locate these products so that their temperatures will not increase due to the effects of heat generated by neighboring components.
- (4) If a vinyl-covered wire comes into contact with the products, then the cover will melt and generate toxic gas, damaging the insulation. Never allow contact between the cover and these products to occur.
- (5) This product should not be stressed or vibrated when reflowed.
- (6) Please keep the following conditions when you install this product for reparation by hand soldering.
- (7) Please do not wash this product.
- (8) Please refer to the recommended pattern when designing a board.
- (9) Pressing on parts of the metal cover or fastening objects to the metal cover is not allowed.

23.3. NOTES OF USAGE CONDITIONS

Benutzerhinweise

- (1) Please take measure against static electricity.
If pulses or other transient loads (a large load applied in a short time) are applied to the products, then before use, check and evaluate their operation when assembled on your products.
- (2) Please do not use the fallen product.
- (3) Please do not put on damage and dirt to the pin , and don't touch the electric components.
- (4) Please follow the condition written in the ratings , about the power supply instruments applied to this product.
- (5) Electrode peeling strength: Do not add pressure of more than 4.9N when soldered on PCB
- (6) Pressing on parts of the metal cover or fastening objects to the metal cover is not allowed.
- (7) These products are intended for general purpose and standard use in general electronic equipment, such as home appliances, office equipment, information and communication equipment.

HIGH FREQUENCY PRODUCTS DIVISION
Module Business
PANASONIC ELECTRONIC DEVICES
EUROPE GmbH

APPROVED
genehmigt

CHECKED
geprüft

DESIGNED
erstellt

CLASSIFICATION Einstufung	PRODUCT SPECIFICATION Produktspezifikation	No. DS-4555-2400-102	REV. A
SUBJECT Thema	MODEM FOR IEEE802.15.4 (ZIGBEE) "ZigBee" Modem" (IEEE802.15.4)	PAGE Seite	19 of 26
CUSTOMER'S CODE PAN4555	PANASONIC'S CODE ENWC9A0xxxEF	DATE Datum	26.04.2007

23.4. NOTES OF STORAGE

Lagerhinweise

- (1) The module may not be stressed mechanically during storage.
- (2) Do not store these products in the following conditions or the performance characteristics of the product, such as RF performance will be adversely affected:
 - Storage in salty air or in an environment with a high concentration of corrosive gas, such as Cl₂, H₂S, NH₃, SO₂, or NOX
 - Storage in direct sunlight
 - Storage in an environment where the temperature may be outside the range of 5°C to 35°C range, or where the humidity may be outside the 45 to 85% range.
 - Storage of the products for more than one year after the date of delivery at your company if all the above conditions (1) to (3) have been avoided
- (3) Storage period: Please check the adhesive strength of the embossed tape and soldering after 6 months of storage.
- (4) Please keep this product away from water, poisonous gas and corrosive gas.
- (5) This product should not be stressed or shocked when transported.
- (6) Please follow the specification when piling up the packed crate (max. 10).

23.5. CAUTIONS FOR SAFETY

Sicherheitshinweise

These specifications are intended to preserve the quality assurance of products as individual components.

Before use, check and evaluate their operation when mounted on your products. Abide by these specifications, without deviation when using the products. These products may short-circuit. If electrical shocks, smoke, fire, and/or accidents involving human life are anticipated when a short circuit occurs, then at least, provide the following failsafe functions, as a minimum.

- (1) Ensure the safety of the whole system by installing a protection circuit and a protection device.
- (2) Ensure the safety of the whole system by installing a redundant circuit or another system to prevent a single fault causing an unsafe status.

23.6. OTHER CAUTIONS

Weitere Hinweise

- (1) This specification sheet is copyrighted. Please do not open it to the third party.
- (2) Please do not use this product of our company for another purpose.
- (3) Be sure to provide an appropriate fail-safe function on your product to prevent a second damage that may be caused by the abnormal function or the failure of our product.
- (4) This product has not been manufactured with any ozone chemical controlled under the Montreal Protocol.
- (5) These products are not intended for other uses, other than under the special conditions shown below. Before using these products under such special conditions, check their performance and reliability under the said special

HIGH FREQUENCY PRODUCTS DIVISION Module Business PANASONIC ELECTRONIC DEVICES EUROPE GmbH	APPROVED genehmigt	CHECKED geprüft	DESIGNED erstellt
--	-----------------------	--------------------	----------------------

CLASSIFICATION Einstufung	PRODUCT SPECIFICATION Produktspezifikation	No. DS-4555-2400-102	REV. A
SUBJECT Thema	MODEM FOR IEEE802.15.4 (ZIGBEE) "ZigBee" Modem" (IEEE802.15.4)	PAGE Seite	20 of 26
CUSTOMER'S CODE PAN4555	PANASONIC'S CODE ENWC9A0xxxEF	DATE Datum	26.04.2007

conditions carefully to determine whether or not they can be used in such a manner.

- In liquid, such as water, salt water, oil, alkali, or organic solvent, or in places where liquid may splash.
 - In direct sunlight, outdoors, or in a dusty environment
 - In an environment where condensation occurs.
 - In an environment with a high concentration of harmful gas (e.g. salty air, HCl, Cl₂, SO₂, H₂S, NH₃, and NO_x)
- (6) If an abnormal voltage is applied due to a problem occurring in other components or circuits, replace these products with new products because they may not be able to provide normal performance even if their electronic characteristics and appearances appear satisfactory.
- (7) When you have any question or uncertainty, both of you and Panasonic sincerely cope with it.

HIGH FREQUENCY PRODUCTS DIVISION
Module Business
PANASONIC ELECTRONIC DEVICES
EUROPE GmbH

APPROVED
genehmigt

CHECKED
geprüft

DESIGNED
erstellt

CLASSIFICATION Einstufung	PRODUCT SPECIFICATION Produktspezifikation	No. DS-4555-2400-102	REV. A
SUBJECT Thema	MODEM FOR IEEE802.15.4 (ZIGBEE) "ZigBee" Modem" (IEEE802.15.4)	PAGE Seite	21 of 26
CUSTOMER'S CODE PAN4555	PANASONIC'S CODE ENWC9A0xxxEF	DATE Datum	26.04.2007

24. PACKAGING Verpackung

24.1. TAPE DIMENSION

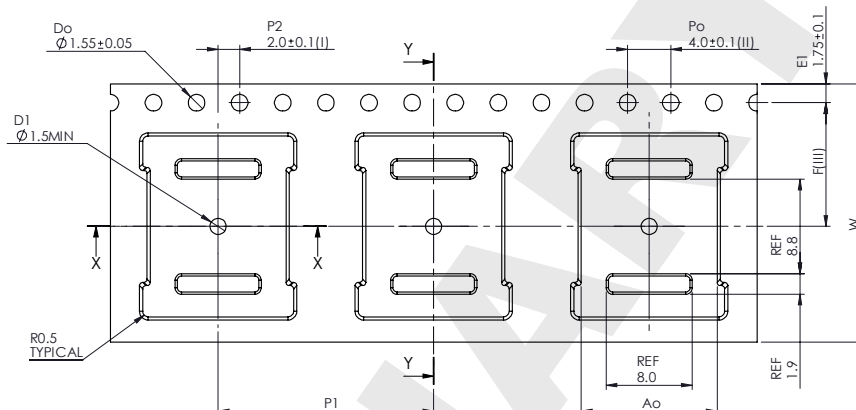
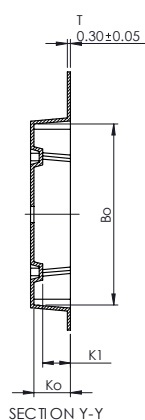

Ao	12.60	+/- 0.1
Bo	16.80	+/- 0.1
Ko	3.40	+/- 0.1
K 1	2.60	+/- 0.1
F	11.50	+/- 0.1
P 1	20.00	+/- 0.1
W	24.00	+/- 0.3

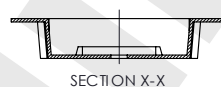
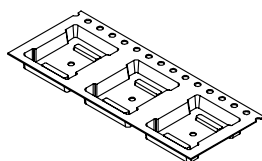

Forming format : Flatbed
Estimated max. length : 60 meter/2263 reel

- (I) Measured from centreline of sprocket hole to centreline of pocket.
- (II) Cumulative tolerance of 10 sprocket holes is ± 0.20 .
- (III) Measured from centreline of sprocket hole to centreline of pocket.
- (IV) Other material available.

ALL DIMENSIONS IN MILLIMETRES UNLESS OTHERWISE STATED.

This package will be available latest as the mass production status are confirmed.

24.2. PACKING IN TAPE

Direction of unreeling (for customer)

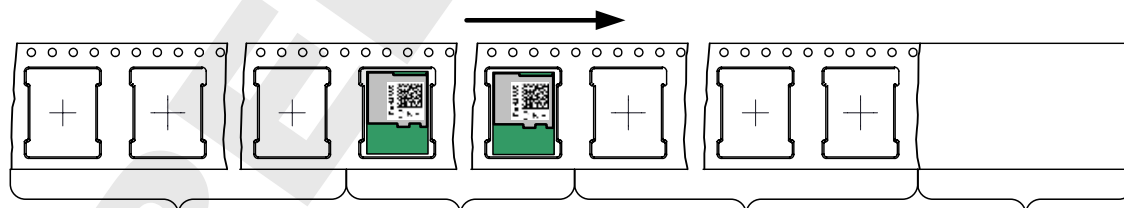

trailer (empty)
1 x circumference /hub
(min. 160mm)

Component packed
area.
Standard 1500pcs

Leader (empty)
minimum 10 pitch

Top cover tape more
than 1 x circumference
plus 100mm to avoid
fixing of tape end on
sealed modules.

Empty hollow in component packed area shall be less than two per reel and those hollows shall not be consecutive.

Top cover tape shall not be found on reel holes and shall not stick out from reel.

HIGH FREQUENCY PRODUCTS DIVISION
Module Business
PANASONIC ELECTRONIC DEVICES
EUROPE GmbH

APPROVED
genehmigt

CHECKED
geprüft

DESIGNED
erstellt

CLASSIFICATION Einstufung	PRODUCT SPECIFICATION Produktspezifikation	No. DS-4555-2400-102	REV. A
SUBJECT Thema	MODEM FOR IEEE802.15.4 (ZIGBEE) "ZigBee" Modem" (IEEE802.15.4)	PAGE Seite	22 of 26
CUSTOMER'S CODE PAN4555	PANASONIC'S CODE ENWC9A0xxxEF	DATE Datum	26.04.2007

24.3. COMPONENT DIRECTION Komponentenanordnung

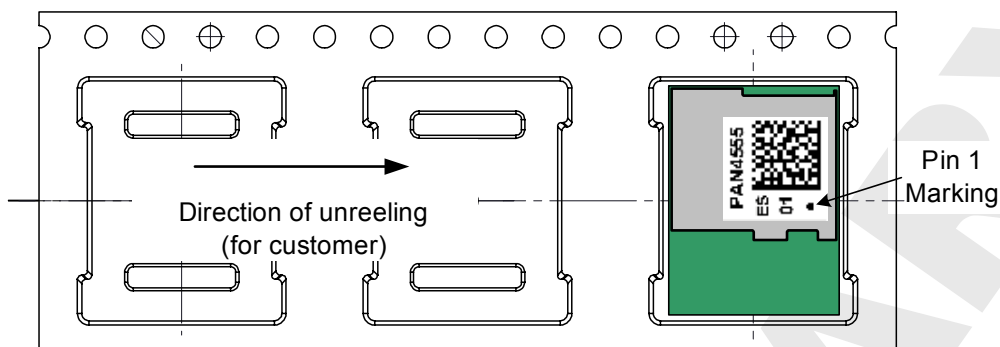

Please refer also to chapter 18. Labeling Drawing

This package will be available latest as the mass production status are confirmed.

24.4. REEL DIMENSION

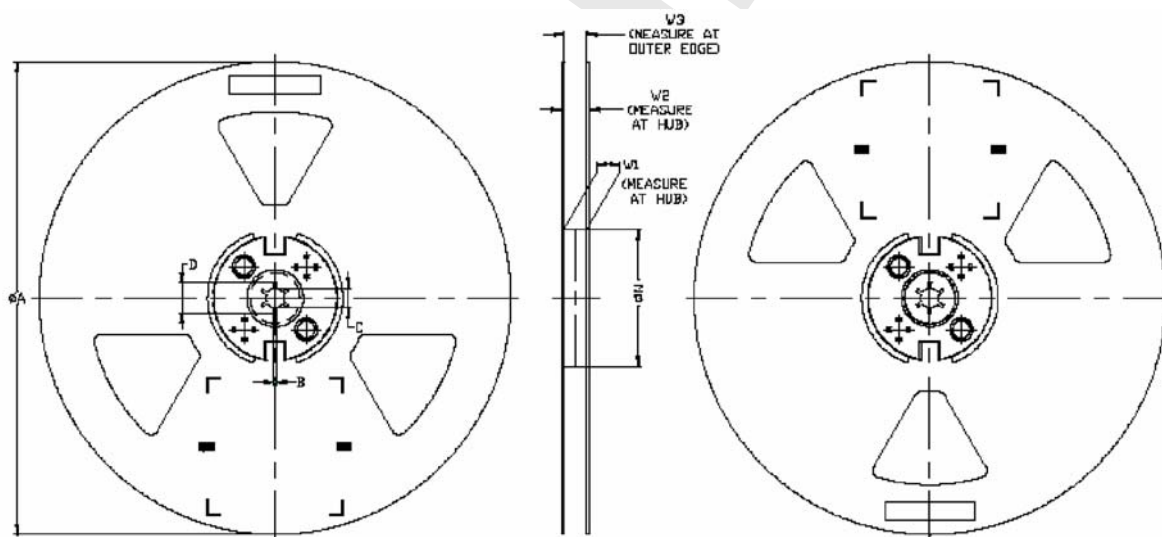

TAPE SIZE	A MAX	B MIN	C	D MIN	N ±1.0	W1	W2 MAX	W3	Assembly Method
24mm	330.0	1.5	13 ^{+0.5} _{-0.2}	20.2	100.0	25.0 ^{+2.0} _{-0.0}	30.4	24.4 ^{+3.0} _{-0.5}	*Latch

All dimensions in millimeters unless otherwise stated

*Latch (2PC)

HIGH FREQUENCY PRODUCTS DIVISION
Module Business
PANASONIC ELECTRONIC DEVICES
EUROPE GmbH

APPROVED
genehmigt

CHECKED
geprüft

DESIGNED
erstellt

CLASSIFICATION Einstufung	PRODUCT SPECIFICATION Produktspezifikation	No. DS-4555-2400-102	REV. A
SUBJECT Thema	MODEM FOR IEEE802.15.4 (ZIGBEE) "ZigBee" Modem" (IEEE802.15.4)	PAGE Seite	23 of 26
CUSTOMER'S CODE PAN4555	PANASONIC'S CODE ENWC9A0xxxEF	DATE Datum	26.04.2007

24.5. LABEL FOR PACKAGE

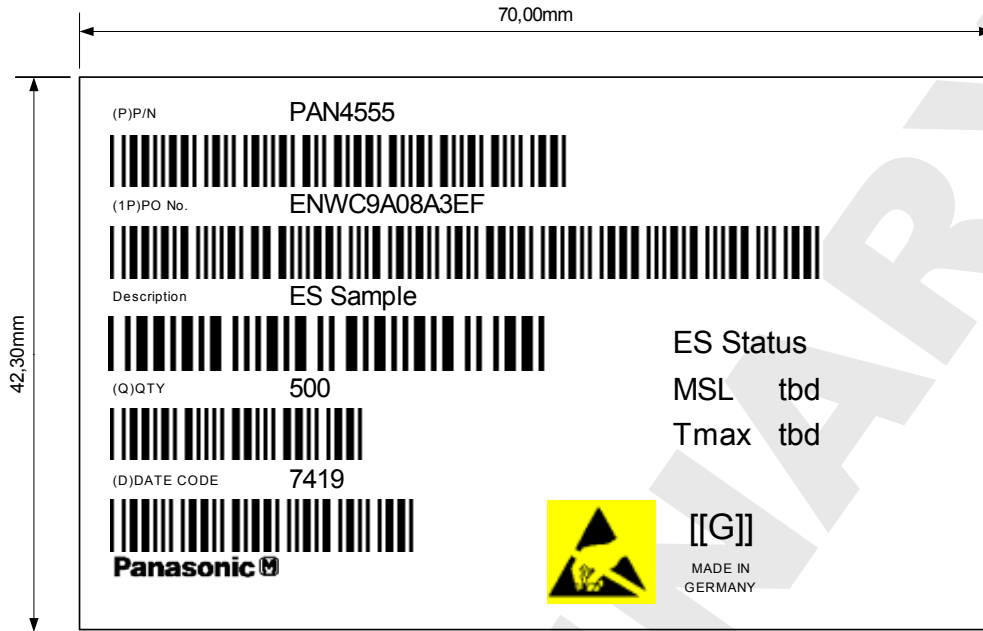

The label must be stick 3 times, reel, barrier bag and inner carton box.

24.6. TOTAL PACKING HANDLING

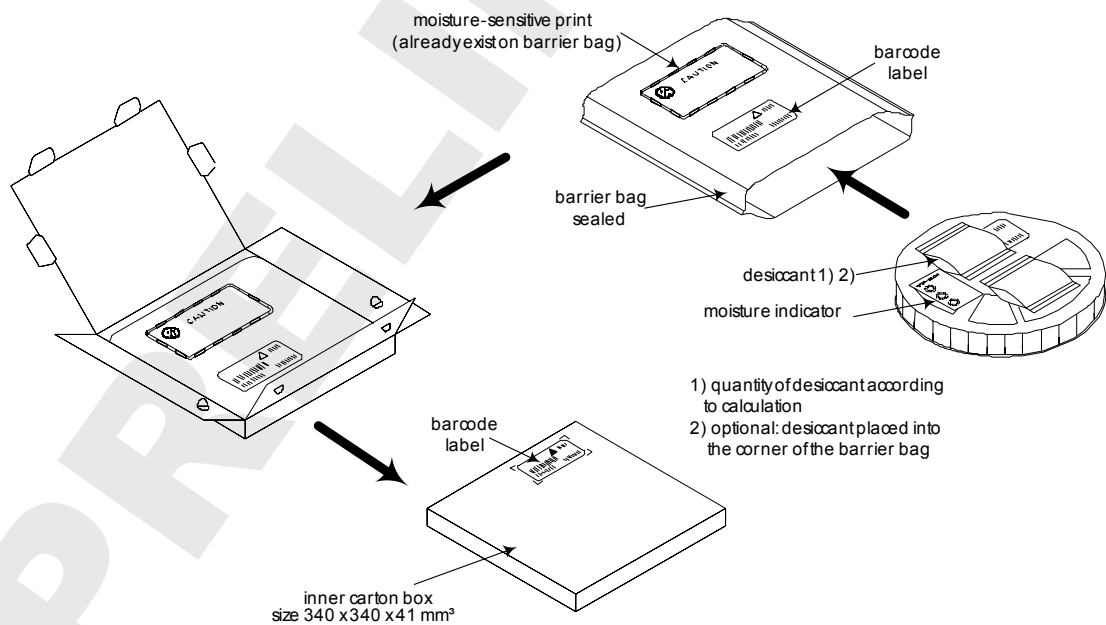

HIGH FREQUENCY PRODUCTS DIVISION
Module Business
PANASONIC ELECTRONIC DEVICES
EUROPE GmbH

APPROVED
genehmigt

CHECKED
geprüft

DESIGNED
erstellt

CLASSIFICATION Einstufung	PRODUCT SPECIFICATION Produktspezifikation	No. DS-4555-2400-102	REV. A
SUBJECT Thema	MODEM FOR IEEE802.15.4 (ZIGBEE) "ZigBee" Modem" (IEEE802.15.4)	PAGE Seite	24 of 26
CUSTOMER'S CODE PAN4555	PANASONIC'S CODE ENWC9A0xxxEF	DATE Datum	26.04.2007

24.7. COVER TAPE REEL STRENGTH

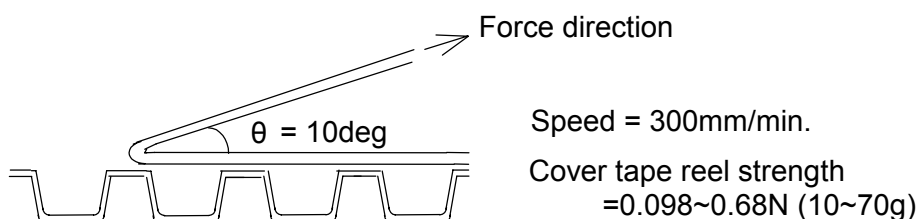

25. ORDERING INFORMATION

Bestellinformationen

Ordering part number	Description	MOQ ⁽¹⁾
ENWCZA08A3EF ⁽²⁾	Engineering Sample ZigBee ready PAN4555, 2.4GHz ZigBee ready with Ceramic Antenna 60kBit Flash Memory	1
ENWCZA09N4EF ⁽²⁾	Engineering Sample ZigBee ready PAN4555, 2.4GHz ZigBee ready with RF out on a SMD pad 60kBit Flash Memory	1
ENWC9A08A3EF ⁽³⁾	Mass Production Sample ZigBee ready PAN4555, 2.4GHz ZigBee ready with Ceramic Antenna 60kBit Flash Memory	1500 ⁽⁴⁾
ENWC9A09N4EF ⁽³⁾	Mass Production Sample ZigBee ready PAN4555, 2.4GHz ZigBee ready with RF out on a SMD pad 60kBit Flash Memory	1500 ⁽⁴⁾

Note:

- (1) Minimum order quantity.
- (2) The "Z" in the ordering part number, refers to the engineering sample status. After mass production the "Z" will be changed to the "9".
- (3) Could only be ordered, if we released the mass production status.
If we finishing, this document will change from PRELIMINARY to RELEASE also the revision status will move from alphabetic numbering to 1.0.
- (4) On special agreement we can also deliver in lower quantity!

HIGH FREQUENCY PRODUCTS DIVISION
Module Business
PANASONIC ELECTRONIC DEVICES
EUROPE GmbH

APPROVED
genehmigt

CHECKED
geprüft

DESIGNED
erstellt

CLASSIFICATION Einstufung	PRODUCT SPECIFICATION Produktspezifikation	No. DS-4555-2400-102	REV. A
SUBJECT Thema	MODEM FOR IEEE802.15.4 (ZIGBEE) "ZigBee" Modem" (IEEE802.15.4)	PAGE Seite	25 of 26
CUSTOMER'S CODE PAN4555	PANASONIC'S CODE ENWC9A0xxxEF	DATE Datum	26.04.2007

26. ROHS DECLARATION

RoHS-Erklärung

Declaration of environmental compatibility for supplied products:

Hereby we declare to our best present knowledge based on declaration of our suppliers that this product do not contain by now the following substances which are banned by Directive 2002/95/EC (RoHS) or if contain a maximum concentration of 0,1% by weight in homogeneous materials for

- Lead and lead compounds
- Mercury and mercury compounds
- Chromium (VI)
- PBB (polybrominated biphenyl) category
- PBDE (polybrominated biphenyl ether) category

And a maximum concentration of 0,01% by weight in homogeneous materials for

- Cadmium and cadmium compounds

27. DATA SHEET STATUS

Datenblatt Status

This data sheet contains data from the PRELIMINARY specification. Supplementary data will be published at a later date. Panasonic Electronic Devices Europe GmbH reserves the right to change the specification without notice, in order to improve the design and supply the best possible product.

Please consult the most recently issued data sheet before initiating or completing a design. If there is an update, please download under: [PAN4555 Latest Data Sheet!](#)

28. RELATED DOCUMENTS

Mitgeltende Dokumente

For an update, please search in the suitable homepage.

- [1] IEEE Standard 802.15.4 –2003 Wireless Medium Access Control (MAC) and Physical Layer (PHY) Specifications for Low-Rate Wireless Personal Area Networks (LR-WPANs)
- [2] Technical Data MC1321x Document Number: MC1321x
Rev. 1.1, 03/2007 Freescale Semiconductor
- [3] MC1321x Reference Manual Document Number: MC1321xRM
Rev. 1.1, 10/2006 Freescale Semiconductor
- [4] Handling MAC Address erasure, AN2825, Rev. 0.0 10/2004, Freescale Semiconductor
- [5] 802154MPSUG 802.15.4 MAC/PHY Software User's Guide, Rev 1.1, Freescale Semiconductor

HIGH FREQUENCY PRODUCTS DIVISION Module Business PANASONIC ELECTRONIC DEVICES EUROPE GmbH	APPROVED genehmigt	CHECKED geprüft	DESIGNED erstellt
--	-----------------------	--------------------	----------------------

CLASSIFICATION Einstufung	PRODUCT SPECIFICATION Produktspezifikation	No. DS-4555-2400-102	REV. A
SUBJECT Thema	MODEM FOR IEEE802.15.4 (ZIGBEE) "ZigBee" Modem" (IEEE802.15.4)	PAGE Seite	26 of 26
CUSTOMER'S CODE PAN4555	PANASONIC'S CODE ENWC9A0xxxEF	DATE Datum	26.04.2007

[6] 802154EBRM.pdf 802.15.4 / ZigBee Embedded Bootloader Reference Manual Rev. 0.0
09/2004

[7] AN2771 ZigBee/802.15.4 PHY Protocol Test Client (PTC) Rev. 0.0 Freescale Semiconductor

[8] Manual to the Evaluation Kit from Panasonic
Downloadable under: www.pedeu.panasonic.de

29. GENERAL INFORMATION Allgemeine Informationen

© Panasonic Electronic Devices Europe GmbH 2007.

All rights reserved.

This product description does not lodge the claim to be complete and free of mistakes.

Please contact the related product manager in every case.

If we deliver samples to the customer, these samples have the status Engineering Samples. This means, the design of this product is not yet concluded. Engineering Samples may be partially or fully functional, and there may be differences to be published Data Sheet. Engineering Samples are not qualified and are not to be used for reliability testing or series production.

Disclaimer:

Customer acknowledges that samples may deviate from the Data Sheet and may bear defects due to their status of development and the lack of qualification mentioned above.

Panasonic Electronic Devices Europe GmbH rejects any liability or product warranty for Engineering Samples. In particular, Panasonic Electronic Devices Europe GmbH disclaims liability for damages caused by

- the use of the Engineering Sample other than for Evaluation Purposes, particularly the installation or integration in an other product to be sold by Customer,
- deviation or lapse in function of Engineering Sample,
- improper use of Engineering Samples.

Panasonic Electronic Devices Europe GmbH disclaims any liability for consequential and incidental damages. In case of any questions, please contact your local sales partner or the related product manager.

30. LIFE SUPPORT POLICY

Politik für Lebenserhaltungssysteme

This Panasonic Electronic Devices Europe GmbH product is not designed for use in life support appliances, devices, or systems where malfunction can reasonably be expected to result in a significant personal injury to the user, or as a critical component in any life support device or system whose failure to perform can be reasonably expected to cause the failure of the life support device or system, or to affect its safety or effectiveness. Customers using or selling these products for use in such applications do so at their own risk and agree to fully indemnify Panasonic Electronic Devices Europe GmbH for any damages resulting.

HIGH FREQUENCY PRODUCTS DIVISION Module Business PANASONIC ELECTRONIC DEVICES EUROPE GmbH	APPROVED genehmigt	CHECKED geprüft	DESIGNED erstellt
			www.DataSheet4U.com