



TONE/PULSE DIALER WITH HANDFREE AND HOLD FUNCTION

GENERAL DESCRIPTION

The W91320 series are Si-gate CMOS IC that provide necessary signal for either Pulse or Tone dialing. It features Handfree dialing, one key redial, Hold and Redial.

FEATURES

- DTMF/PULSE switchable dialer.
- 32 digits for Redial memory.
- Pulse to Tone (*T) keypad for Long Distance Call operation.
- 4 × 5 keyboard can be used.
- Easy operation with Redial, Flash, Pause and *T keypads.
- Pause, P-->T (Pulse to Tone) can be stored as a digit in memory.
- Minimum tone output duration : 100 msec.
- Minimum inter tone pause : 100 msec.
- Power on reset on chip.
- 3.579545 MHz crystal or ceramic resonator is used.
- 18, or 20 pin DIP plastic package.
- The different types of W91320 series are shown as the following Table 1.

TABLE 1:

TYPE NO.	PULSE (pps)	FLASH (ms)	M/B	H/ P MUTE	HANDFREE	PACKAGE
W91320	10	600/ 98	Pin	Yes	-	18
W91320A	10	600/ 98	Pin	Yes	Yes	20
W91321	10/20	600/305	1:2	Yes	-	18
W91321A	10/20	600/305	1:2	Yes	Yes	20

W91320/A				
MODE PIN	TONE/PULSE	DIAL RATE	M/B RATIO	FLASH TIME
V _{DD}	Pulse	10 pps	2 : 3	F1 = 600 mS F2 = 98 mS
Floating	Pulse	10 pps	1 : 2	
V _{SS}	Tone	-	-	

W91321/A				
MODE PIN	TONE/PULSE	DIAL RATE	M/B RATIO	FLASH TIME
V _{DD}	Pulse	10 pps	1 : 2	F1 = 600 mS F2 = 305 mS
Floating	Pulse	20 pps	1 : 2	
V _{SS}	Tone	-	-	

TONE/PULSE DIALER

PIN CONFIGURATION

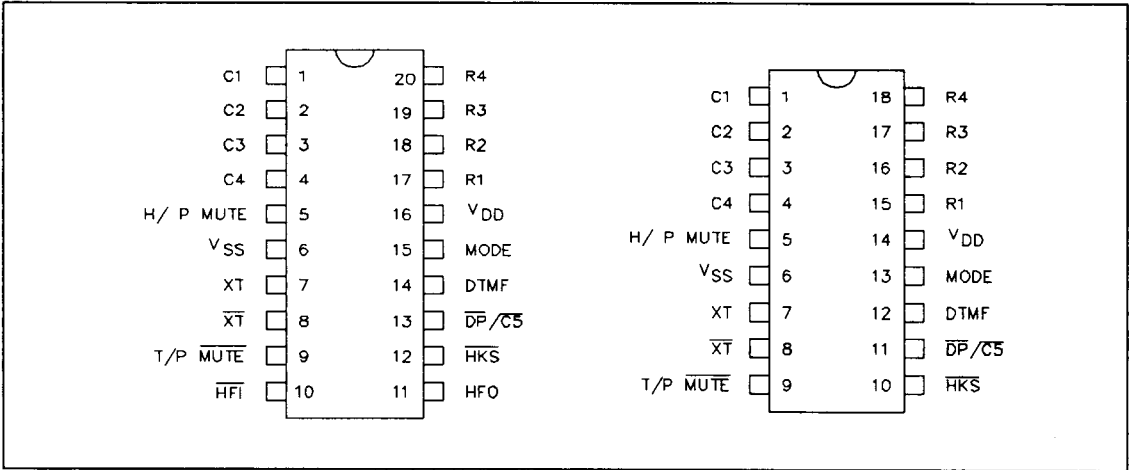

BLOCK DIAGRAM

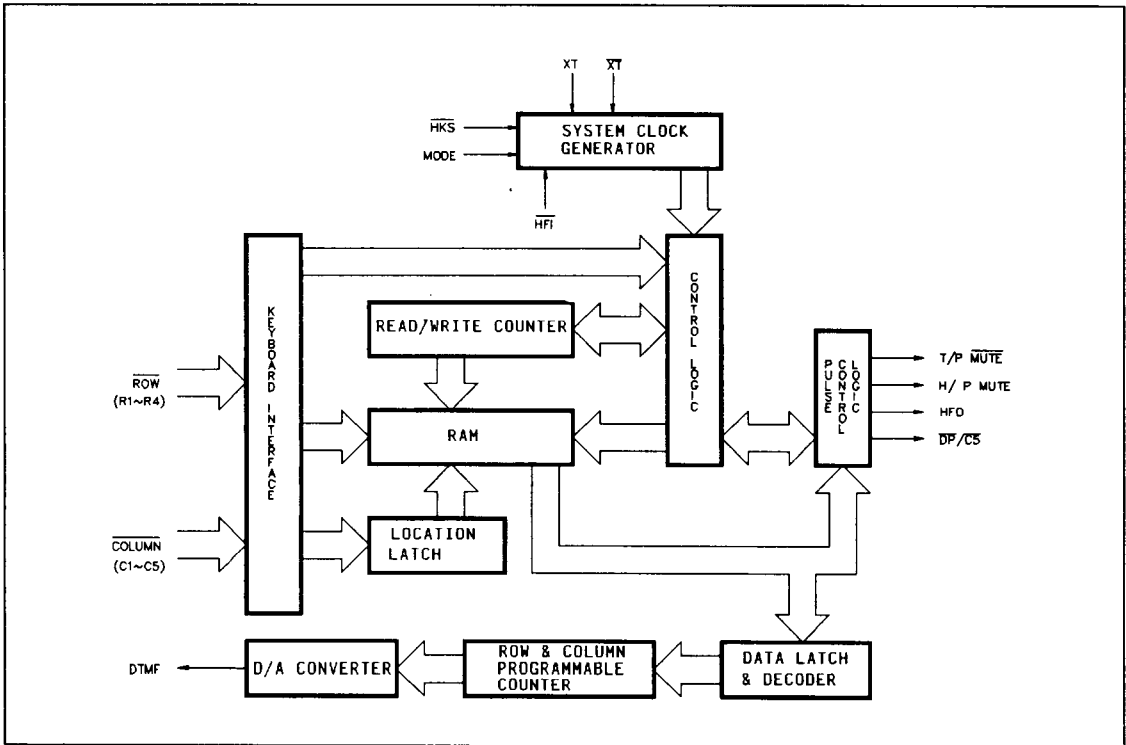

PIN DESCRIPTION

SYMBOL	18 PIN	20 PIN	I/O	FUNCTION																																				
Column-Row Inputs	1-4 & 15-18	1-4 & 17-20	I	The Keyboard input may be used with either the standard 4X5 keyboard or the inexpensive single contact (Form A) keyboard, the electronic input with μC , that also can be connected to be used. A valid key entry is defined by a single row being connected to a single column.																																				
XT	7	7	I	A built in inverter provides oscillation with an inexpensive 3.579545MHz crystal or ceramic resonator.																																				
\overline{XT}	8	8	0	The oscillator output pin.																																				
T/P \overline{MUTE}	9	9	0	The T/P \overline{MUTE} is a conventional CMOS N-channel open drain output. The output transistor is switched on during Pulse and Tone mode dialing sequence and Flash break. Otherwise, it is switched off.																																				
MODE	13	15	I	Pull mode pin to V_{SS} ; the dialer is in Tone mode. Pull mode pin to V_{DD} ; the dialer is in Pulse mode-10pps, M/B=2:3. Pull mode pin to floating; the dialer is in Pulse mode-10pps, M/B=1:2.																																				
\overline{HKS}	10	12	I	This pin is the hook switch input. $\overline{HKS}=1$, ON HOOK state, chip in sleeping mode, no operation. $\overline{HKS}=0$, OFF HOOK state, enable chip on normal operation. This pin must combine to HFI, HFO to perform the above function. Please refer to HFI, HFO pins. \overline{HKS} pin is pulled to V_{DD} by internal resistor.																																				
$\overline{DP}/\overline{CS}$	11	13	0	Open drain dialing pulse output (Fig. 1). Flash key and one key redial will cause \overline{DP} active either in Tone mode or Pulse mode.																																				
DTMF	12	14	0	In pulse mode, it always keeps at low state. In tone mode, it will output a dual or single tone. The detailed timing diagram of tone mode is shown in Fig.2(a,b). <table border="1" style="margin-left: auto; margin-right: auto;"> <thead> <tr> <th colspan="4">OUTPUT FREQUENCY (Hz)</th> </tr> <tr> <th></th> <th>Specified</th> <th>Actual</th> <th>Error %</th> </tr> </thead> <tbody> <tr> <td>R1</td> <td>697</td> <td>699</td> <td>+ 0.28</td> </tr> <tr> <td>R2</td> <td>770</td> <td>766</td> <td>- 0.52</td> </tr> <tr> <td>R3</td> <td>852</td> <td>848</td> <td>- 0.47</td> </tr> <tr> <td>R4</td> <td>941</td> <td>948</td> <td>+ 0.74</td> </tr> <tr> <td>C1</td> <td>1209</td> <td>1216</td> <td>+ 0.57</td> </tr> <tr> <td>C2</td> <td>1336</td> <td>1332</td> <td>- 0.30</td> </tr> <tr> <td>C3</td> <td>1477</td> <td>1472</td> <td>- 0.34</td> </tr> </tbody> </table>	OUTPUT FREQUENCY (Hz)					Specified	Actual	Error %	R1	697	699	+ 0.28	R2	770	766	- 0.52	R3	852	848	- 0.47	R4	941	948	+ 0.74	C1	1209	1216	+ 0.57	C2	1336	1332	- 0.30	C3	1477	1472	- 0.34
OUTPUT FREQUENCY (Hz)																																								
	Specified	Actual	Error %																																					
R1	697	699	+ 0.28																																					
R2	770	766	- 0.52																																					
R3	852	848	- 0.47																																					
R4	941	948	+ 0.74																																					
C1	1209	1216	+ 0.57																																					
C2	1336	1332	- 0.30																																					
C3	1477	1472	- 0.34																																					

SYMBOL	18 PIN	20 PIN	I/O	FUNCTION																																								
V_{DD}, V_{SS}	14, 6	16, 6	I	Power input pins.																																								
\overline{HFI}, HFO	-	10, 11	I, O	<p>Handfree control pins. When \overline{HFI} input pin has a low pulse, the handfree control state is toggled on. Status of the handfree control state is listed in the following table :</p> <table border="1"> <thead> <tr> <th colspan="2">CURRENT STATE</th> <th colspan="3">NEXT STATE</th> </tr> <tr> <th>Hook SW.</th> <th>HFO</th> <th>Input</th> <th>HFO</th> <th>Dialing?</th> </tr> </thead> <tbody> <tr> <td>-</td> <td>Low</td> <td>$\overline{HFI} \downarrow$</td> <td>High</td> <td>Yes</td> </tr> <tr> <td>On Hook</td> <td>High</td> <td>$\overline{HFI} \downarrow$</td> <td>Low</td> <td>No</td> </tr> <tr> <td>Off Hook</td> <td>High</td> <td>$\overline{HFI} \downarrow$</td> <td>Low</td> <td>Yes</td> </tr> <tr> <td>On Hook</td> <td>-</td> <td>Off Hook</td> <td>Low</td> <td>Yes</td> </tr> <tr> <td>Off Hook</td> <td>Low</td> <td>On Hook</td> <td>Low</td> <td>No</td> </tr> <tr> <td>Off Hook</td> <td>High</td> <td>On Hook</td> <td>High</td> <td>Yes</td> </tr> </tbody> </table> <p>\overline{HFI} pin is pulled to V_{DD} by internal resistor. The control function and Hold function relationship is shown in Fig.3.</p>	CURRENT STATE		NEXT STATE			Hook SW.	HFO	Input	HFO	Dialing?	-	Low	$\overline{HFI} \downarrow$	High	Yes	On Hook	High	$\overline{HFI} \downarrow$	Low	No	Off Hook	High	$\overline{HFI} \downarrow$	Low	Yes	On Hook	-	Off Hook	Low	Yes	Off Hook	Low	On Hook	Low	No	Off Hook	High	On Hook	High	Yes
CURRENT STATE		NEXT STATE																																										
Hook SW.	HFO	Input	HFO	Dialing?																																								
-	Low	$\overline{HFI} \downarrow$	High	Yes																																								
On Hook	High	$\overline{HFI} \downarrow$	Low	No																																								
Off Hook	High	$\overline{HFI} \downarrow$	Low	Yes																																								
On Hook	-	Off Hook	Low	Yes																																								
Off Hook	Low	On Hook	Low	No																																								
Off Hook	High	On Hook	High	Yes																																								
H/ P MUTE	5	5	O	The H/ P MUTE is a conventional inverter output. In pulse dialing, flash and hold period, the output will be at active high, otherwise it will keep at low state.																																								

FUNCTIONAL DESCRIPTION

A. Keyboard Operation

	C1	C2	C3	C4	$\overline{C5}$
R1	1	2	3		
R2	4	5	6	F1	
R3	7	8	9	F2	H
R4	* / T	0	#	R / P	R

- F1, F2 -- Flash keys.
Flash keys can not be stored in memory.
- * / T -- In the Pulse mode this key works as Pulse-->Tone key, and it works as * key in the tone mode.
* / T key can be stored as a digit in Pulse or Tone mode.

- R/P -- Redial and Pause function key.
The Redial function can be executed only in first key-in after OFF HOOK, otherwise it will be operated as Pause function.
The Redial function has not break function.
- R -- One key Redial key.
The one key redial function has no break function in the first key-in after OFF HOOK.
The one key redial function uses the redial buffer same as the redial function (R/P), and it is active during normal dialing or repertory dialing.
- H -- Hold function key.

B. Normal Dialing

OFF HOOK (or **ON HOOK** & **HFI** ↓), **D1**,
D2, - - - -, **Dn**

1. **D1**, **D2**, - - - -, **Dn** will be dialed out.
2. Dialing length is unlimited, but the Redial is inhibited if it oversteps 32 digits.

C. Redialing

1. **OFF HOOK**, **D1**, **D2**, - - - -, **Dn**, **BUSY**,
Come **ON HOOK**, **OFF HOOK** (or **ON HOOK**
& **HFI** ↓), **R/P**
or **ON HOOK** & **HFI** ↓, **D1**, **D2**, - - - -,
Dn, **BUSY**, **HFI** ↓, Come **HFI** ↓
, **R/P**

- a. The **R/P** key can execute Redial function only in first key-in after **OFF HOOK**, otherwise it will be Pause function.
2. **OFF HOOK** (or **ON HOOK** & **HFI** ↓), **D1**,
D2, - - - -, **Dn**, **BUSY** **R**
- a. The one key Redialing function timing diagram is shown in Fig.4.
 - b. If the dialing of **D1** to **Dn** is finished, pressing **R** key will cause the Pulse output pin to go low for 2.2 seconds break time and 600 ms pause will automatically be added.
 - c. If the pulses of the dialed number with **D1** to **Dn** have not finished, pressing the **R** key will be ignored.
3. **OFF HOOK**, **D1**, **D2**, - - - -, **Dn**,
BUSY **ON HOOK** come **OFF HOOK** **R**
- a. If **R** is the first key after **OFF HOOK**, it only can execute Redialing function and it will not cause the Pulse output pin to go low for the break time of 2.2 seconds.

D. Access Pause

OFF HOOK (or **ON HOOK** & **HFI** ↓), **D1**,
D2, **R/P**, **D3**, - - -, **Dn**

1. The Pause function can be stored in memory.
2. The Pause function is executed in normal dialing or Redialing or memory dialing.
3. The pause function timing diagram is shown in Fig.5.

E. Pulse to Tone (* / T)

OFF HOOK (or **ON HOOK** & **HFI** ↓), **D1**,
D2, - - - -, **Dn**, *** / T**, **D1'**,
D2', - - - -, **Dn'**

1. If the mode switch is set in Pulse mode, then the output signal will be:
D1, **D2**, - - -, **Dn**, Pause (3.6s)
(Pulse)
D1', **D2'**, - - - -, **Dn'**
(Tone)
2. If the mode switch is set in Tone mode, then the output signal will be:
D1, **D2**, - - -, **Dn**
(Tone)
, * , **D1'**, **D2'**, - - - -, **Dn'**
(Tone) (Tone)
3. It can be reset to Pulse mode only in operation of **ON HOOK**, because it's still in Tone mode when the digits have been dialed out.
4. The P --> T function timing diagram is shown in Fig.6.

F. Flash (F1 or F2)

OFF HOOK (or **ON HOOK** & **HFI** ↓), **FL**

1. Flash key can not be stored as a digit in memory and it has the first priority of the keyboard function.
2. The system will return to the initial state after the break time is finished.
3. The Flash function timing diagram is shown in Fig.7.

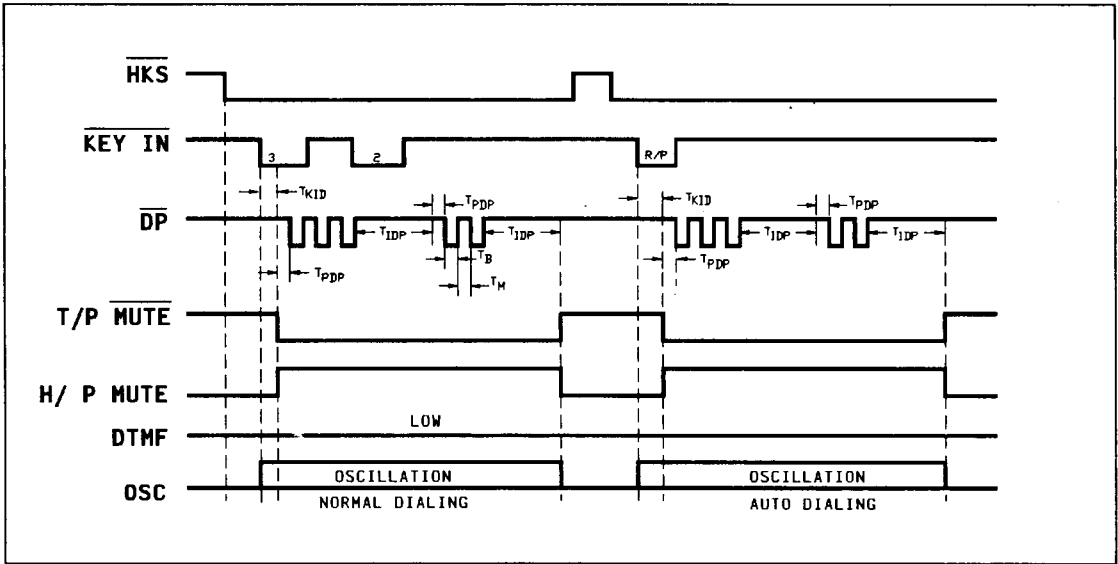

Figure 1. Pulse Mode Timing Diagram

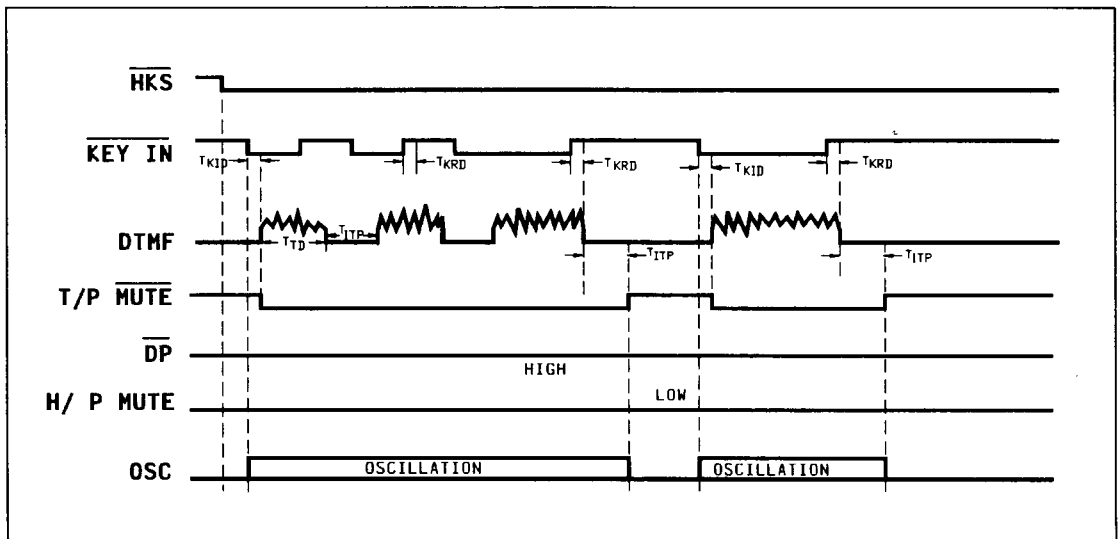

Figure 2(a). Tone Mode Normal Dialing Timing Diagram

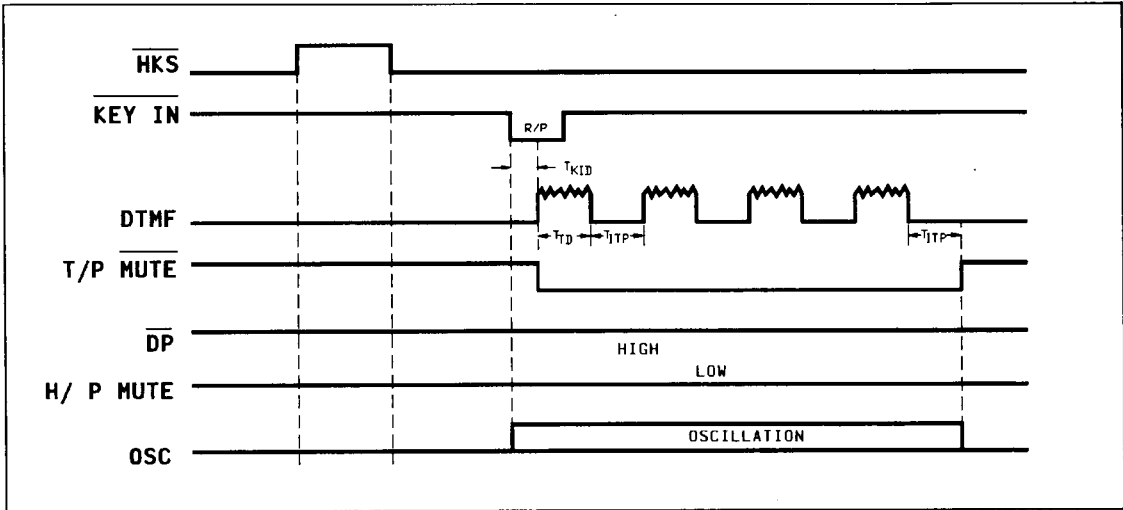

Figure 2(b). Tone Mode Auto Dialing Timing Diagram

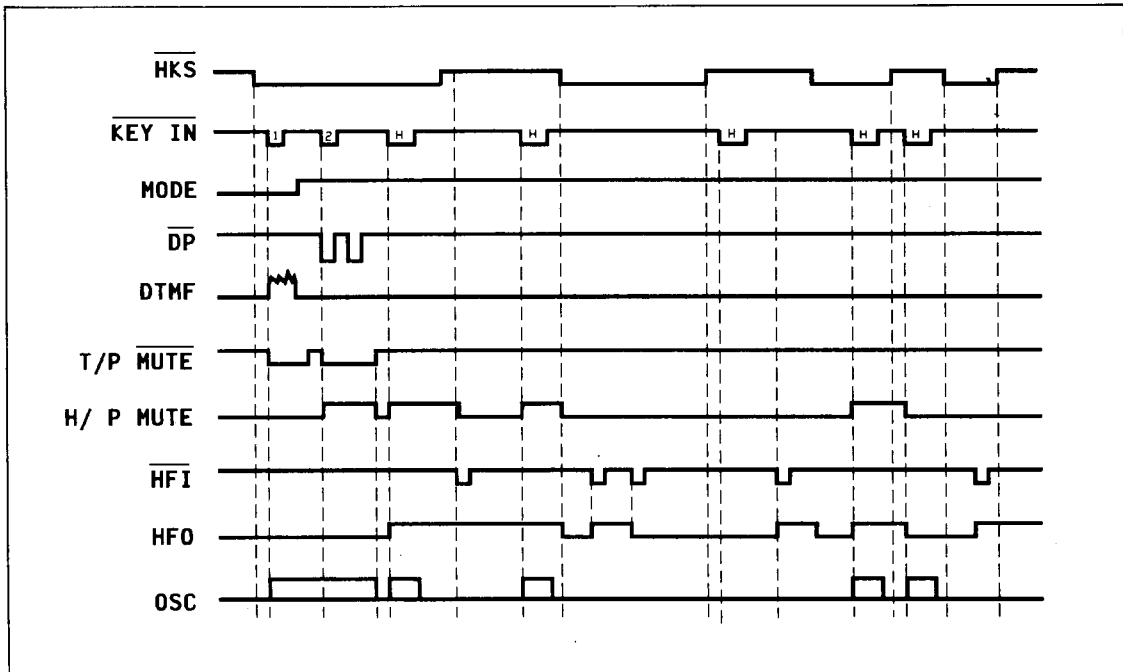

Figure 3.

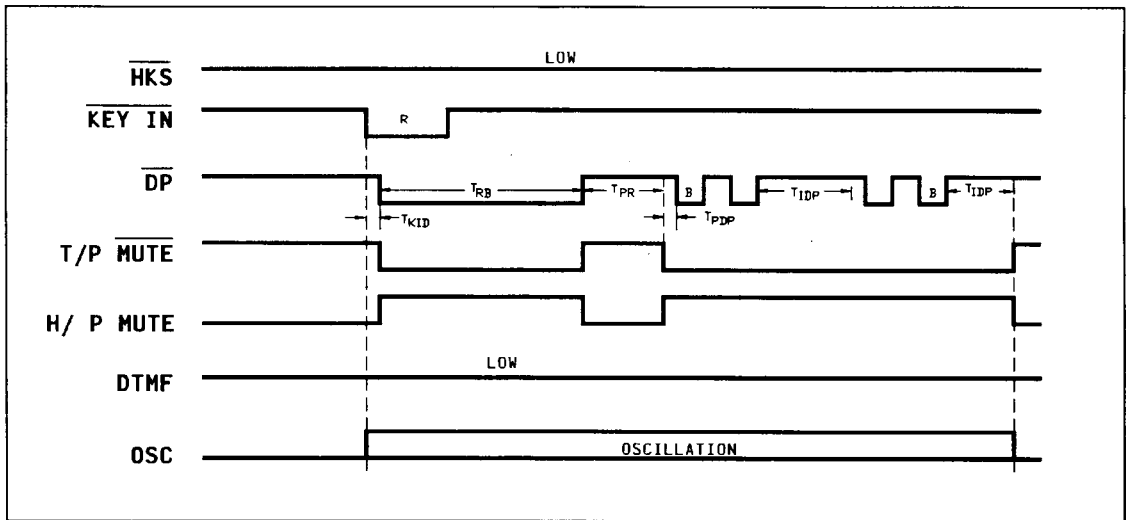

Figure 4. Pulse Mode Timing Diagram

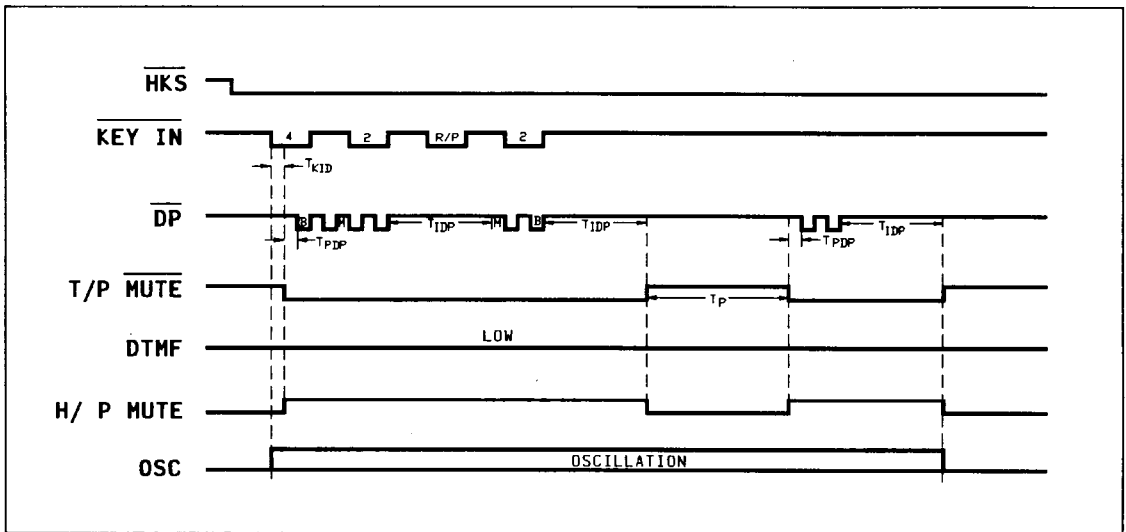

Figure 5. Pause Function Timing Diagram

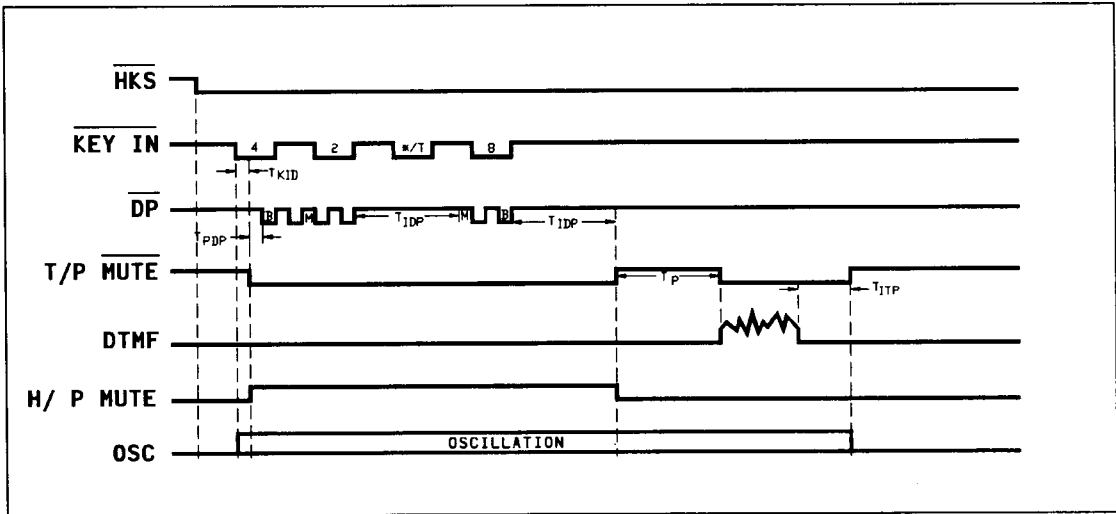

Figure 6. P-->T Operation Timing Diagram in Normal Dialing

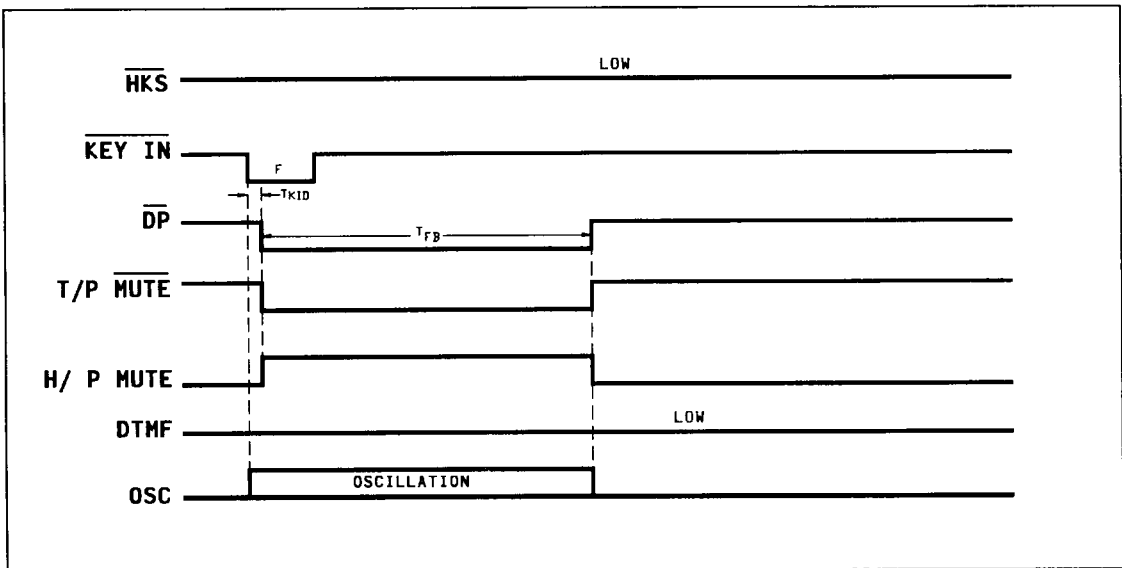

Figure 7. Flash Operating Timing Diagram

TONE/PULSE
DIALER

ABSOLUTE MAXIMUM RATING

PARAMETER	SYMBOL	RATING	UNIT
DC Supply Voltage	$V_{DD} - V_{SS}$	-0.3 ~ +7.0	V
Input/Output Voltage	V_{IL}	$V_{SS} - 0.3$	V
	V_{IH}	$V_{DD} + 0.3$	V
	V_{OL}	$V_{SS} - 0.3$	V
	V_{OH}	$V_{DD} + 0.3$	V
Power Dissipation	P_D	120	mW
Operating Temperature	T_{OPR}	-20 ~ 70	°C
Storage Temperature	T_{STG}	-55 ~ +150	°C

DC CHARACTERISTICS

($V_{DD} - V_{SS} = 2.5$ V , $F_{osc} = 3.58$ MHz , $T_a = 25$ °C , All output unloaded)

PARAMETER	SYMBOL	CONDITIONS	MIN.	TYP.	MAX.	UNIT
Operating Voltage	V_{DD}	-	2.0	-	5.5	V
Operating Current	I_{OP}	Tone	-	0.30	0.50	mA
		Pulse	-	0.15	0.30	
Standby Current	I_{SB}	$\overline{HKS} = 0$, No load & No key entry	-	-	15	μA
Memory Retention Current	I_{MR}	$\overline{HKS} = 1$, $V_{DD} = 1.0$ V	-	-	0.2	μA
DTMF Output Voltage	V_{TO}	Row group, $R_L = 5k\Omega$	130	150	170	mVrms
Pre-emphasis		Col/Row, $V_{DD} = 2.0-5.5$ V	1	2	3	dB
DTMF Distortion	T_{HD}	$R_L = 5k\Omega$, $V_{DD} = 2.0-5.5$ V	-	-30	-23	dB
DTMF Output DC Level	V_{TDC}	$R_L = 5k\Omega$, $V_{DD} = 2.0-5.5$ V	1.1	-	2.8	V
DTMF Output Sink Current	I_{TL}	$V_{TO} = 0.5$ V	0.2	-	-	mA
\overline{DP} Output Sink Current	I_{PL}	$V_{PO} = 0.5$ V	0.5	-	-	mA
T/P MUTE Output Sink Current	I_{ML}	$V_{MO} = 0.5$ V	0.5	-	-	mA
\overline{HKS} I/P Pull High Resister	R_{KH}		-	300	-	kΩ
HFO Drive/Sink Current	I_{HFH}	$V_{HFH} = 2.0$ V	0.5	-	-	mA
	I_{HFL}	$V_{HFL} = 0.5$ V	0.5	-	-	
Keypad Input Drive current	I_{Kd}	$V_I = 0$ V	4	-	30	μA
Keypad Input Sink Current	I_{KS}	$V_I = 2.5$ V	200	400	-	μA
Keypad Resistance			-	-	5.0	kΩ

AC CHARACTERISTICS

PARAMETER	SYMBOL	CONDITIONS	MIN.	TYP.	MAX.	UNIT
Keypad Active in Debounce	T_{KID}		-	20	-	mS
Key Release Debounce	T_{KRD}		-	20	-	mS
Pre-digit-pause (1)	T_{PDP1} 10 pps	M/B = 2:3	-	40	-	mS
		M/B = 1:2	-	33.3	-	
Pre-digit-pause (2)	T_{PDP2} 20 pps	M/B = 2:3	-	20	-	mS
		M/B = 1:2	-	16.7	-	
Inter Digit Pause (Auto Dialing)	T_{IDP}	10 pps	-	800	-	mS
		20 pps	-	500	-	
Make / Break Ratio	M/B	M/B = 2/3	-	40:60	-	%
		M/B = 1/2	-	33:67	-	
DTMF Output Duration	T_{TD}	Auto Dialing	-	100	-	mS
Inter Tone Pause	T_{ITP}		-	100	-	mS
Flash Break Time	T_{FB}		-	98	-	mS
		-	305	-		
		-	600	-		
Pause Time	T_P		-	3.6	-	S
One Key Redialing Pause Time	T_{PR}		-	600	-	mS
One Key Redialing Break Time	T_{RB}		-	2.2	-	S

APPLICATION CIRCUIT

