



512 bit (64 bit x8) Serial Access TIMEKEEPER[®] SRAM

FEATURES SUMMARY

- 5V \pm 10% SUPPLY VOLTAGE
- COUNTERS FOR SECONDS, MINUTES, HOURS, DAY, DATE, MONTH, YEARS, AND CENTURY
- YEAR 2000 COMPLIANT
- SOFTWARE CLOCK CALIBRATION
- AUTOMATIC POWER-FAIL DETECT AND SWITCH CIRCUITRY
- I²C BUS COMPATIBLE
- 56 BYTES OF GENERAL PURPOSE RAM
- ULTRA-LOW BATTERY SUPPLY CURRENT OF 450nA
- LOW OPERATING CURRENT OF 300 μ A
- OPERATING TEMPERATURE OF -40 to 85°C
- AUTOMATIC LEAP YEAR COMPENSATION
- SPECIAL SOFTWARE PROGRAMMABLE OUTPUT
- PACKAGING OPTIONS INCLUDE:
 - 28-lead SOIC and SNAPHAT[®] TOP (to be ordered separately)
 - SO8

Figure 1. 8-pin SOIC Package

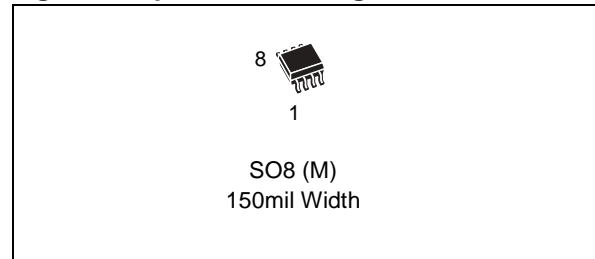

Figure 2. 28-pin SOIC Package

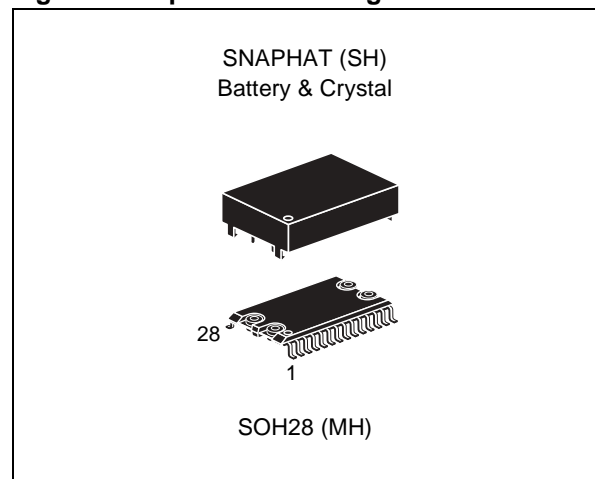

TABLE OF CONTENTS

FEATURES SUMMARY	1
Figure 1. 8-pin SOIC Package	1
Figure 2. 28-pin SOIC Package	1
SUMMARY DESCRIPTION	4
Figure 3. Logic Diagram	4
Table 1. Signal Names	4
Figure 4. 8-pin SOIC Connections	5
Figure 5. 28-pin SOIC Connections	5
Figure 6. Block Diagram	5
OPERATION	6
2-Wire Bus Characteristics	6
Bus not busy	6
Start data transfer	6
Stop data transfer	6
Data valid	6
Acknowledge	6
Figure 7. Serial Bus Data Transfer Sequence	7
Figure 8. Acknowledge Sequence	7
Figure 9. Bus Timing Requirements Sequence	8
Table 2. AC Characteristics	8
READ Mode	9
Figure 10. Slave Address Location	9
Figure 11. READ Mode Sequence	9
Figure 12. Alternative READ Mode Sequence	10
WRITE Mode	10
Data Retention Mode	10
Figure 13. WRITE Mode Sequence	10
CLOCK OPERATION	11
Table 3. Register Map	11
Clock Calibration	12
Figure 14. Crystal Accuracy Across Temperature	13
Figure 15. Clock Calibration	13
Output Driver Pin	14
Initial Power-on Defaults	14
MAXIMUM RATING	14
Table 4. Absolute Maximum Ratings	14
DC AND AC PARAMETERS	15
Table 5. Operating and AC Measurement Conditions	15

Figure 16.AC Measurement I/O Waveform	15
Table 6. Capacitance.	15
Table 7. DC Characteristics.	16
Table 8. Crystal Electrical Characteristics.	16
Figure 17.Power Down/Up Mode AC Waveforms	17
Table 9. Power Down/Up Mode AC Characteristics	17
Table 10. Power Down/Up Trip Points DC Characteristics.	17
PACKAGE MECHANICAL INFORMATION	18
Figure 18.SO8 – 8-pin Plastic Small Package Outline	18
Table 11. SO8 – 8-pin Plastic Small Outline, Package Mechanical Data	18
Figure 19.SOH28 – 28-lead Plastic Small Outline, 4-socket battery SNAPHAT, Package Outline.	19
Table 12. SOH28 – 28-lead Plastic Small Outline, 4-socket battery SNAPHAT, Mech. Data.	19
Figure 20.SH – 4-pin SNAPHAT Housing for 48mAh Battery & Crystal, Package Outline	20
Table 13. SH – 4-pin SNAPHAT Housing for 48mAh Battery & Crystal, Package Mech. Data.	20
Figure 21.SH – 4-pin SNAPHAT Housing for 120mAh Battery & Crystal, Package Outline	21
Table 14. SH – 4-pin SNAPHAT Housing for 120mAh Battery & Crystal, Package Mech. Data.	21
PART NUMBERING	22
Table 15. Ordering Information Scheme	22
Table 16. SNAPHAT Battery/Crystal Table	22
REVISION HISTORY	23
Table 17. Document Revision History	23

SUMMARY DESCRIPTION

The M41T56 TIMEKEEPER[®] is a low power, 512-bit static CMOS RAM organized as 64 words by 8 bits. A built-in 32,768Hz oscillator (external crystal controlled) and the first 8 bytes of the RAM are used for the clock/calendar function and are configured in binary coded decimal (BCD) format. Addresses and data are transferred serially via a two-line, bi-directional bus. The built-in address register is incremented automatically after each WRITE or READ data byte.

The M41T56 clock has a built-in power sense circuit which detects power failures and automatically switches to the battery supply during power failures. The energy needed to sustain the RAM and clock operations can be supplied from a small lithium coin cell.

Typical data retention time is in excess of 10 years with a 50mAh, 3V lithium cell. The M41T56 is supplied in an 8-lead Plastic SOIC package or a 28-lead SNAPHAT[®] package.

The 28-pin, 330mil SOIC provides sockets with gold plated contacts at both ends for direct connection to a separate SNAPHAT housing containing the battery and crystal. The unique design allows the SNAPHAT battery package to be mounted on top of the SOIC package after the completion of the surface mount process. Insertion of the SNAPHAT housing after reflow prevents potential battery and crystal damage due to the high temperatures required for device surface-mounting. The SNAPHAT housing is keyed to prevent reverse insertion. The SOIC and battery/crystal packages are shipped separately in plastic anti-static tubes or in Tape & Reel form.

For the 28-lead SOIC, the battery/crystal package (e.g., SNAPHAT) part number is "M4Txx-BR12SH" (see Table 16., page 22).

Caution: Do not place the SNAPHAT battery/crystal package "M4Txx-BR12SH" in conductive foam as this will drain the lithium button-cell battery.

Figure 3. Logic Diagram

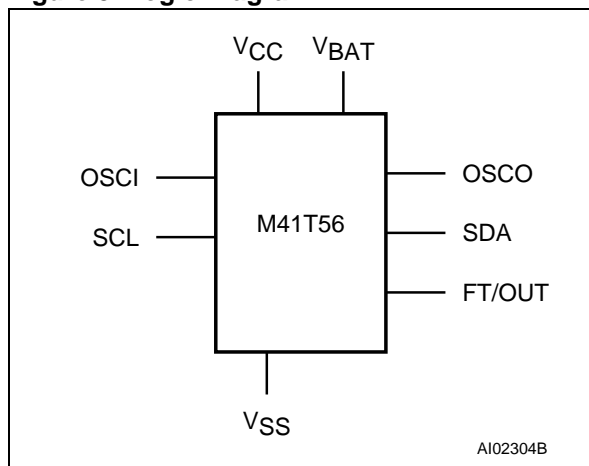

Table 1. Signal Names

OSCI	Oscillator Input
OCSO	Oscillator Output
FT/OUT	Frequency Test / Output Driver (Open Drain)
SDA	Serial Data Address Input / Output
SCL	Serial Clock
VBAT	Battery Supply Voltage
VCC	Supply Voltage
VSS	Ground

Figure 4. 8-pin SOIC Connections

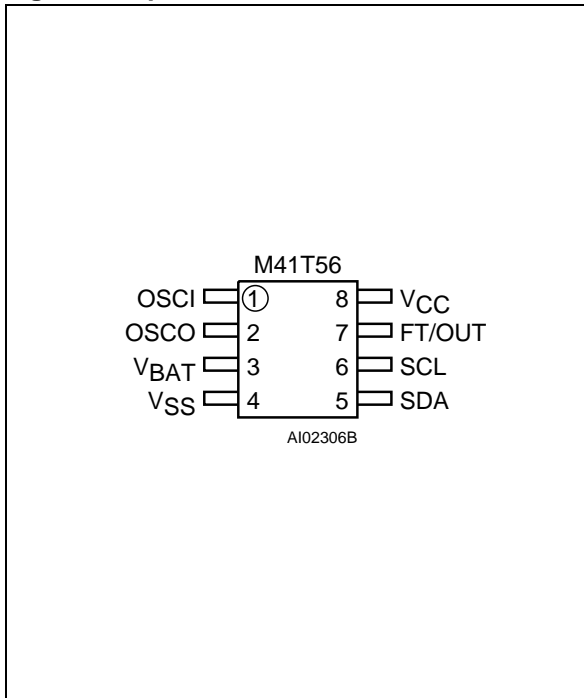

Figure 5. 28-pin SOIC Connections

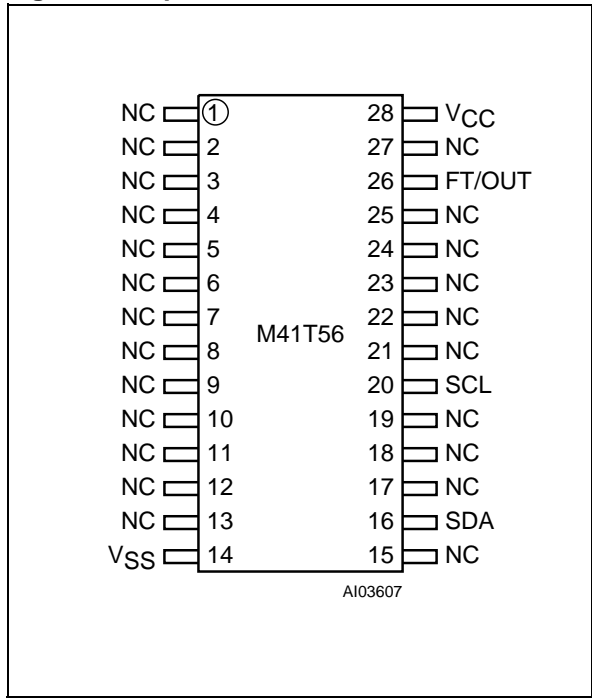
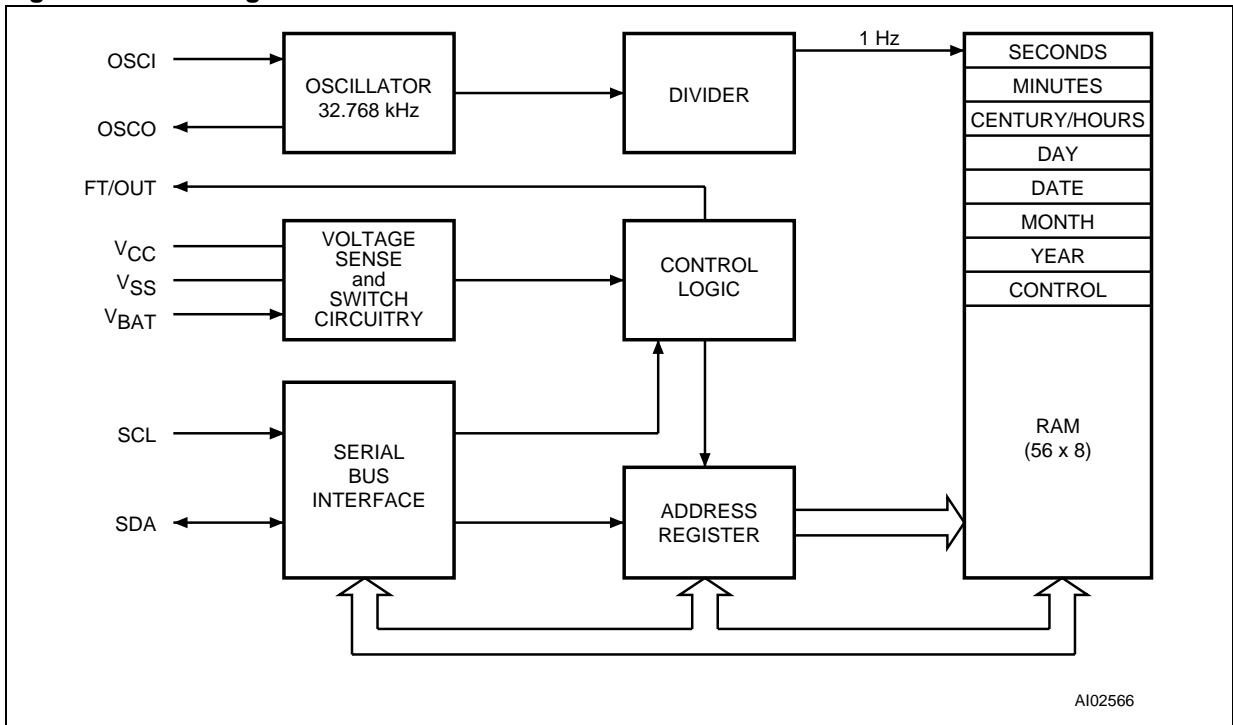

Figure 6. Block Diagram



OPERATION

The M41T56 clock operates as a slave device on the serial bus. Access is obtained by implementing a start condition followed by the correct slave address (D0h). The 64 bytes contained in the device can then be accessed sequentially in the following order:

1. Seconds Register
2. Minutes Register
3. Century/Hours Register
4. Day Register
5. Date Register
6. Month Register
7. Years Register
8. Control Register

9 to 64.RAM

The clock continually monitors V_{CC} for an out of tolerance condition. Should V_{CC} fall below V_{PFD} , the device terminates an access in progress and resets the device address counter. Inputs to the device will not be recognized at this time to prevent erroneous data from being written to the device from an out of tolerance system. When V_{CC} falls below V_{BAT} , the device automatically switches over to the battery and powers down into an ultra low current mode of operation to conserve battery life. Upon power-up, the device switches from battery to V_{CC} at V_{BAT} and recognizes inputs when V_{CC} goes above V_{PFD} volts.

2-Wire Bus Characteristics

This bus is intended for communication between different ICs. It consists of two lines: one bi-directional for data signals (SDA) and one for clock signals (SCL). Both the SDA and the SCL lines must be connected to a positive supply voltage via a pull-up resistor.

The following protocol has been defined:

- Data transfer may be initiated only when the bus is not busy.
- During data transfer, the data line must remain stable whenever the clock line is High.
- Changes in the data line while the clock line is High will be interpreted as control signals.

Accordingly, the following bus conditions have been defined:

Bus not busy. Both data and clock lines remain High.

Start data transfer. A change in the state of the data line, from High to Low, while the clock is High, defines the START condition.

Stop data transfer. A change in the state of the data line, from Low to High, while the clock is High, defines the STOP condition.

Data valid. The state of the data line represents valid data when after a start condition, the data line is stable for the duration of the High period of the clock signal. The data on the line may be changed during the Low period of the clock signal. There is one clock pulse per bit of data.

Each data transfer is initiated with a start condition and terminated with a stop condition. The number of data bytes transferred between the start and stop conditions is not limited. The information is transmitted byte-wide and each receiver acknowledges with a ninth bit.

By definition, a device that gives out a message is called "transmitter," the receiving device that gets the message is called "receiver." The device that controls the message is called "master." The devices that are controlled by the master are called "slaves."

Acknowledge. Each byte of eight bits is followed by one Acknowledge Bit. This Acknowledge Bit is a low level put on the bus by the receiver, whereas the master generates an extra acknowledge related clock pulse.

A slave receiver which is addressed is obliged to generate an acknowledge after the reception of each byte. Also, a master receiver must generate an acknowledge after the reception of each byte that has been clocked out of the slave transmitter.

The device that acknowledges has to pull down the SDA line during the acknowledge clock pulse in such a way that the SDA line is a stable Low during the High period of the acknowledge related clock pulse. Of course, setup and hold times must be taken into account. A master receiver must signal an end-of-data to the slave transmitter by not generating an acknowledge on the last byte that has been clocked out of the slave. In this case, the transmitter must leave the data line High to enable the master to generate the STOP condition.

Figure 7. Serial Bus Data Transfer Sequence

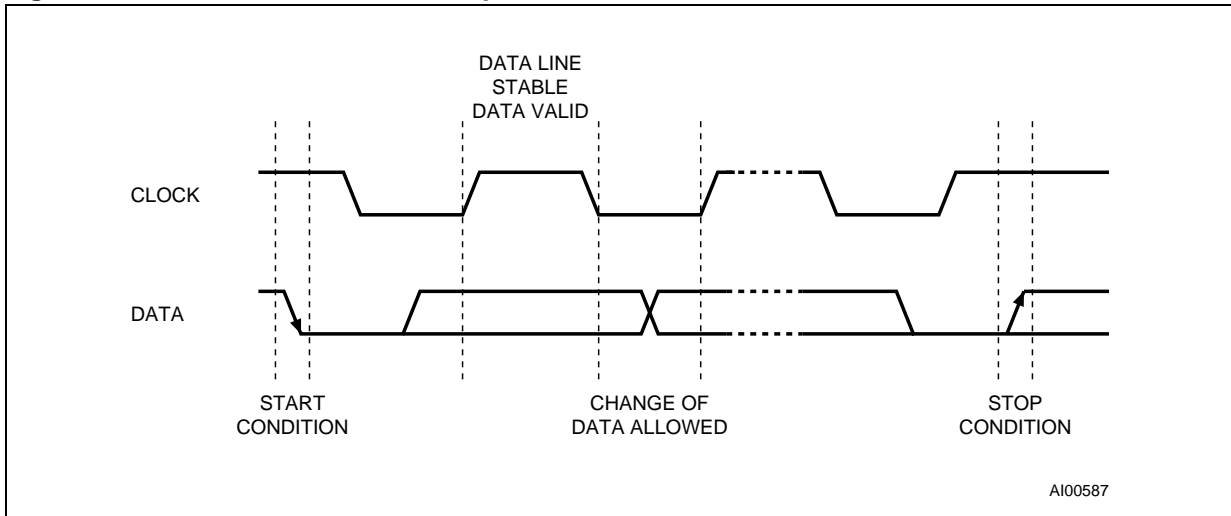

Figure 8. Acknowledge Sequence

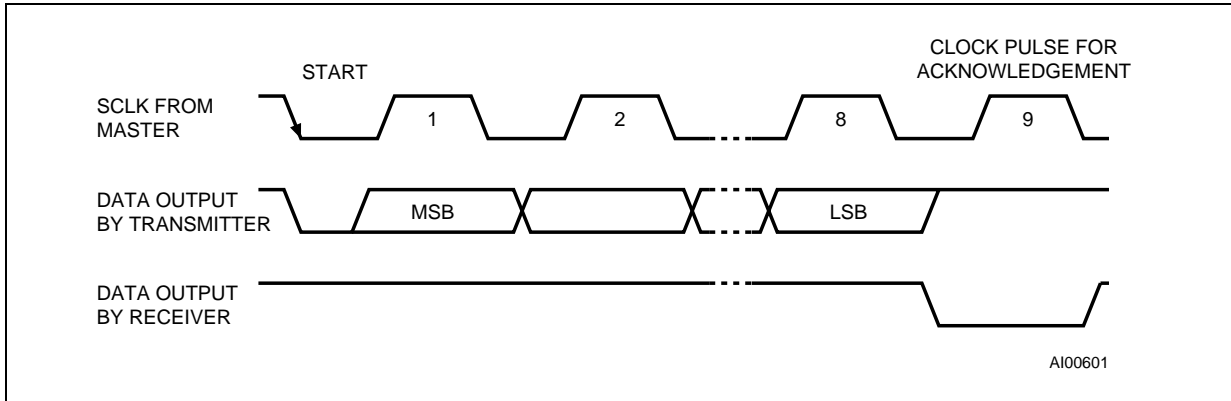

Figure 9. Bus Timing Requirements Sequence

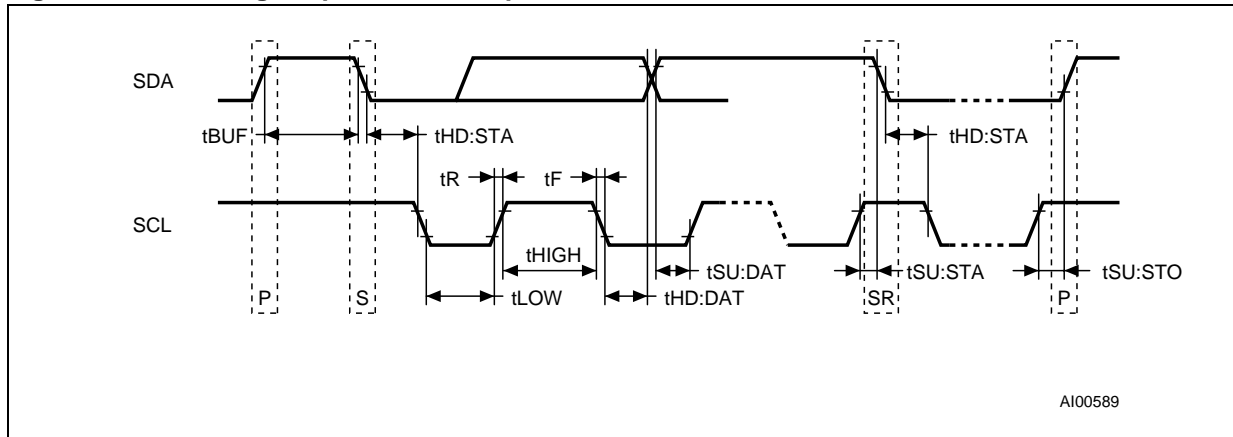

Table 2. AC Characteristics

Symbol	Parameter ⁽¹⁾	Min	Max	Unit
f_{SCL}	SCL Clock Frequency	0	100	kHz
t_{LOW}	Clock Low Period	4.7		μs
t_{HIGH}	Clock High Period	4		μs
t_R	SDA and SCL Rise Time		1	μs
t_F	SDA and SCL Fall Time		300	ns
$t_{HD:STA}$	START Condition Hold Time (after this period the first clock pulse is generated)	4		μs
$t_{SU:STA}$	START Condition Setup Time (only relevant for a repeated start condition)	4.7		μs
$t_{SU:DAT}$	Data Setup Time	250		ns
$t_{HD:DAT}^{(2)}$	Data Hold Time	0		μs
$t_{SU:STO}$	STOP Condition Setup Time	4.7		μs
t_{BUF}	Time the bus must be free before a new transmission can start	4.7		μs

Note: 1. Valid for Ambient Operating Temperature: $T_A = -40$ to $85^\circ C$; $V_{CC} = 4.5$ to $5.5V$ (except where noted).
 2. Transmitter must internally provide a hold time to bridge the undefined region (300ns max.) of the falling edge of SCL.

READ Mode

In this mode, the master reads the M41T56 slave after setting the slave address (see Figure 10 and Figure 11., page 9). Following the WRITE Mode Control Bit ($R/\bar{W} = 0$) and the Acknowledge Bit, the word address A_n is written to the on-chip address pointer. Next the START condition and slave address are repeated, followed by the READ Mode Control Bit ($R/\bar{W} = 1$). At this point, the master transmitter becomes the master receiver. The data byte which was addressed will be transmitted and the master receiver will send an Acknowledge Bit to the slave transmitter. The address pointer is only incremented on reception of an Acknowledge

Bit. The M41T56 slave transmitter will now place the data byte at address $A_n + 1$ on the bus. The master receiver reads and acknowledges the new byte and the address pointer is incremented to $A_n + 2$. This cycle of reading consecutive addresses will continue until the master receiver sends a STOP condition to the slave transmitter.

An alternate READ Mode may also be implemented, whereby the master reads the M41T56 slave without first writing to the (volatile) address pointer. The first address that is read is the last one stored in the pointer, see Figure 12., page 10.

Figure 10. Slave Address Location

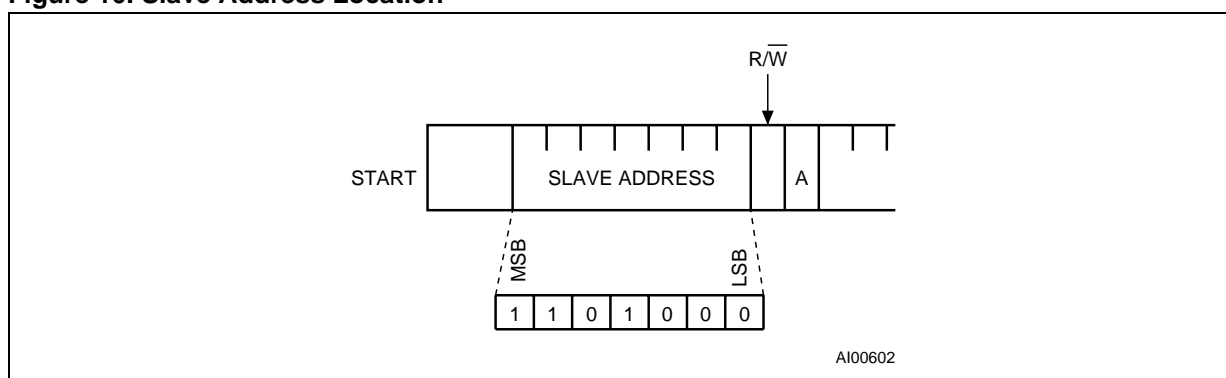

Figure 11. READ Mode Sequence

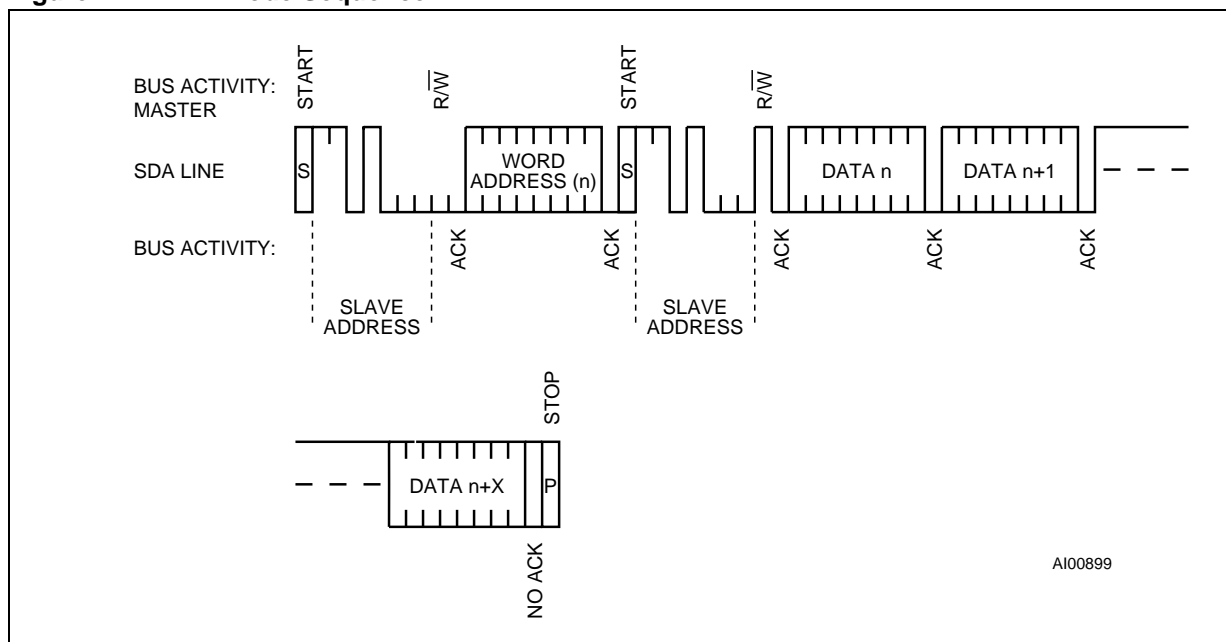
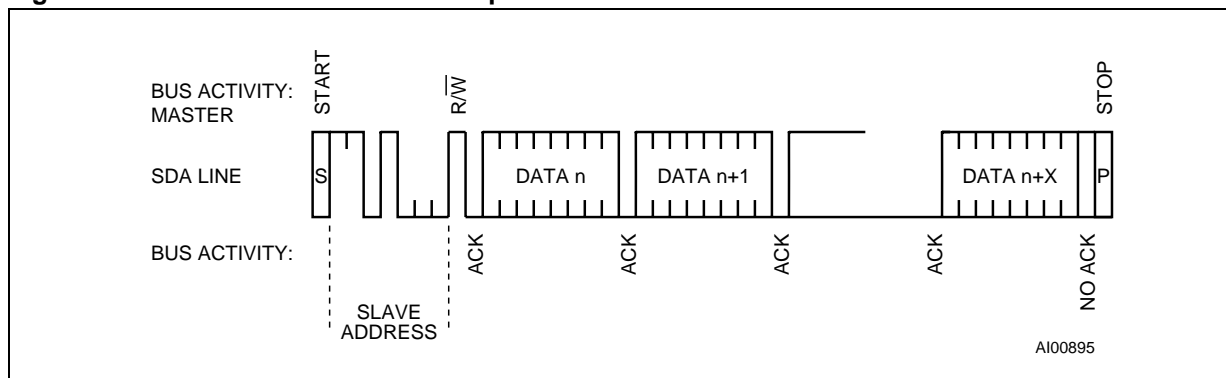

Figure 12. Alternative READ Mode Sequence



WRITE Mode

In this mode the master transmitter transmits to the M41T56 slave receiver. Bus protocol is shown in Figure 13., page 10. Following the START condition and slave address, a logic '0' (R/W = 0) is placed on the bus and indicates to the addressed device that word address A_n will follow and is to be written to the on-chip address pointer. The data word to be written to the memory is strobed in next and the internal address pointer is incremented to the next memory location within the RAM on the reception of an acknowledge clock. The M41T56 slave receiver will send an acknowledge clock to the master transmitter after it has received the slave address and again after it has received the word address and each data byte (see Figure 10).

Data Retention Mode

With valid V_{CC} applied, the M41T56 can be accessed as described above with READ or WRITE cycles. Should the supply voltage decay, the M41T56 will automatically deselect, write protecting itself when V_{CC} falls between V_{PFD} (max) and V_{PFD} (min). This is accomplished by internally inhibiting access to the clock registers and SRAM. When V_{CC} falls below the Battery Back-up Switchover Voltage (V_{SO}), power input is switched from the V_{CC} pin to the battery and the clock registers and SRAM are maintained from the attached battery supply.

All outputs become high impedance. On power up, when V_{CC} returns to a nominal value, write protection continues for t_{REC} .

For a further more detailed review of battery life-time calculations, please see Application Note AN1012.

Figure 13. WRITE Mode Sequence

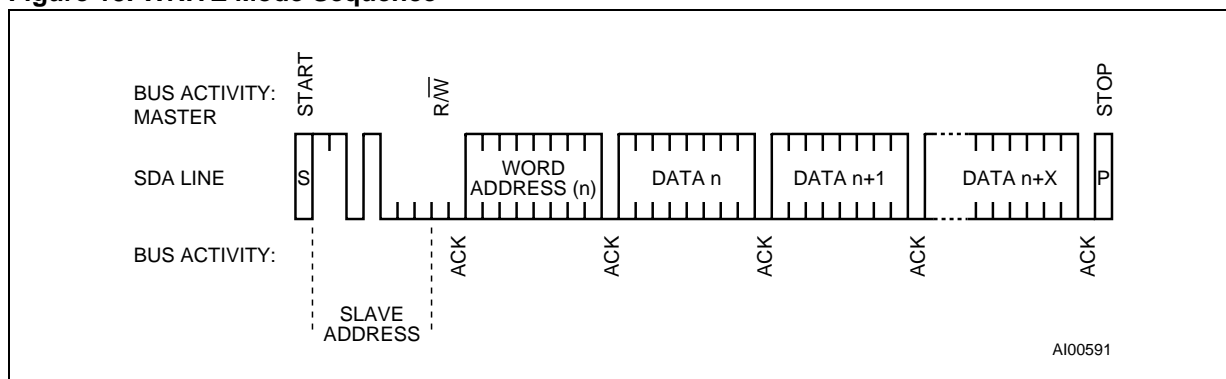

CLOCK OPERATION

The eight byte clock register (see Table 3) is used to both set the clock and to read the date and time from the clock, in a binary coded decimal format. Seconds, Minutes, and Hours are contained within the first three registers. Bits D6 and D7 of Clock Register 2 (Hours Register) contain the CENTURY ENABLE Bit (CEB) and the CENTURY Bit (CB). Setting CEB to a '1' will cause CB to toggle, either from '0' to '1' or from '1' to '0' at the turn of the century (depending upon its initial state). If CEB is set to a '0,' CB will not toggle. Bits D0 through D2 of Register 3 contain the Day (day of week). Registers 4, 5, and 6 contain the Date (day of month), Month, and Years. The final register is the Control Register (this is described in the Clock Calibration section). Bit D7 of Register 0 contains the STOP Bit (ST). Setting this bit to a '1' will cause the oscillator to stop.

If the device is expected to spend a significant amount of time on the shelf, the oscillator may be stopped to reduce current drain. When reset to a '0' the oscillator restarts within one second.

The seven Clock Registers may be read one byte at a time, or in a sequential block. The Control Register (Address location 7) may be accessed independently. Provision has been made to assure that a clock update does not occur while any of the seven clock addresses are being read. If a clock address is being read, an update of the clock registers will be delayed by 250ms to allow the READ to be completed before the update occurs. This will prevent a transition of data during the READ.

Note: This 250ms delay affects only the clock register update and does not alter the actual clock time.

Table 3. Register Map

Address	Data								Function/Range BCD Format	
	D7	D6	D5	D4	D3	D2	D1	D0		
0	ST	10 Seconds			Seconds				Seconds	00-59
1	X	10 Minutes			Minutes				Minutes	00-59
2	CEB ⁽¹⁾	CB	10 Hours		Hours				Century/Hours	0-1/00-23
3	X	X	X	X	X	Day			Day	01-07
4	X	X	10 Date		Date				Date	01-31
5	X	X	X	10 M.	Month				Month	01-12
6	10 Years			Years				Year	00-99	
7	OUT	FT	S	Calibration				Control		

Keys: S = SIGN Bit

FT = FREQUENCY TEST Bit

ST = STOP Bit

OUT = Output level

X = Don't care

CEB = Century Enable Bit

CB = Century Bit

Note: 1. When CEB is set to '1,' CB will toggle from '0' to '1' or from '1' to '0' every 100 years (dependent upon the initial value set).

2. When CEB is set to '0,' CB will not toggle.

Clock Calibration

The M41T56 is driven by a quartz-controlled oscillator with a nominal frequency of 32,768Hz. The devices are tested not to exceed 35 ppm (parts per million) oscillator frequency error at 25°C, which equates to about ± 1.53 minutes per month. With the calibration bits properly set, the accuracy of each M41T56 improves to better than ± 2 ppm at 25°C.

The oscillation rate of any crystal changes with temperature (see [Figure 14., page 13](#)). Most clock chips compensate for crystal frequency and temperature shift error with cumbersome “trim” capacitors. The M41T56 design, however, employs periodic counter correction. The calibration circuit adds or subtracts counts from the oscillator divider circuit at the divide by 256 stage, as shown in [Figure 14., page 13](#). The number of times pulses are blanked (subtracted, negative calibration) or split (added, positive calibration) depends upon the value loaded into the five-bit Calibration Byte found in the Control Register. Adding counts speeds the clock up, subtracting counts slows the clock down.

The Calibration Byte occupies the five lower order bits (D4-D0) in the Control Register (Addr 7). This byte can be set to represent any value between 0 and 31 in binary form. Bit D5 is the Sign Bit; '1' indicates positive calibration, '0' indicates negative calibration. Calibration occurs within a 64 minute cycle. The first 62 minutes in the cycle may, once per minute, have one second either shortened by 128 or lengthened by 256 oscillator cycles. If a binary '1' is loaded into the register, only the first 2 minutes in the 64 minutes cycle will be modified; if a binary 6 is loaded, the first 12 will be affected, and so on.

Therefore, each calibration step has the effect of adding 512 or subtracting 256 oscillator cycles for every 125,829,120 actual oscillator cycles, that is +4.068 or -2.034 ppm of adjustment per calibration step in the calibration register. Assuming that the oscillator is in fact running at exactly 32,768Hz, each of the 31 increments in the Calibration Byte would represent +10.7 or -5.35 seconds per month which corresponds to a total range of +5.5 or -2.75 minutes per month.

Two methods are available for ascertaining how much calibration a given M41T56 may require. The first involves simply setting the clock, letting it run for a month and comparing it to a known accurate reference (like WWV broadcasts). While that may seem crude, it allows the designer to give the end user the ability to calibrate his clock as his environment may require, even after the final product is packaged in a non-user serviceable enclosure. All the designer has to do is provide a simple utility that accessed the Calibration Byte.

The second approach is better suited to a manufacturing environment, and involves the use of some test equipment. When the Frequency Test (FT) Bit, the seventh-most significant bit in the Control Register, is set to a '1,' and the oscillator is running at 32,768Hz, the FT/OUT pin of the device will toggle at 512Hz. Any deviation from 512Hz indicates the degree and direction of oscillator frequency shift at the test temperature.

For example, a reading of 512.01024Hz would indicate a +20ppm oscillator frequency error, requiring a -10(XX001010) to be loaded into the Calibration Byte for correction.

Note: Setting or changing the Calibration Byte does not affect the Frequency Test output frequency.

Figure 14. Crystal Accuracy Across Temperature

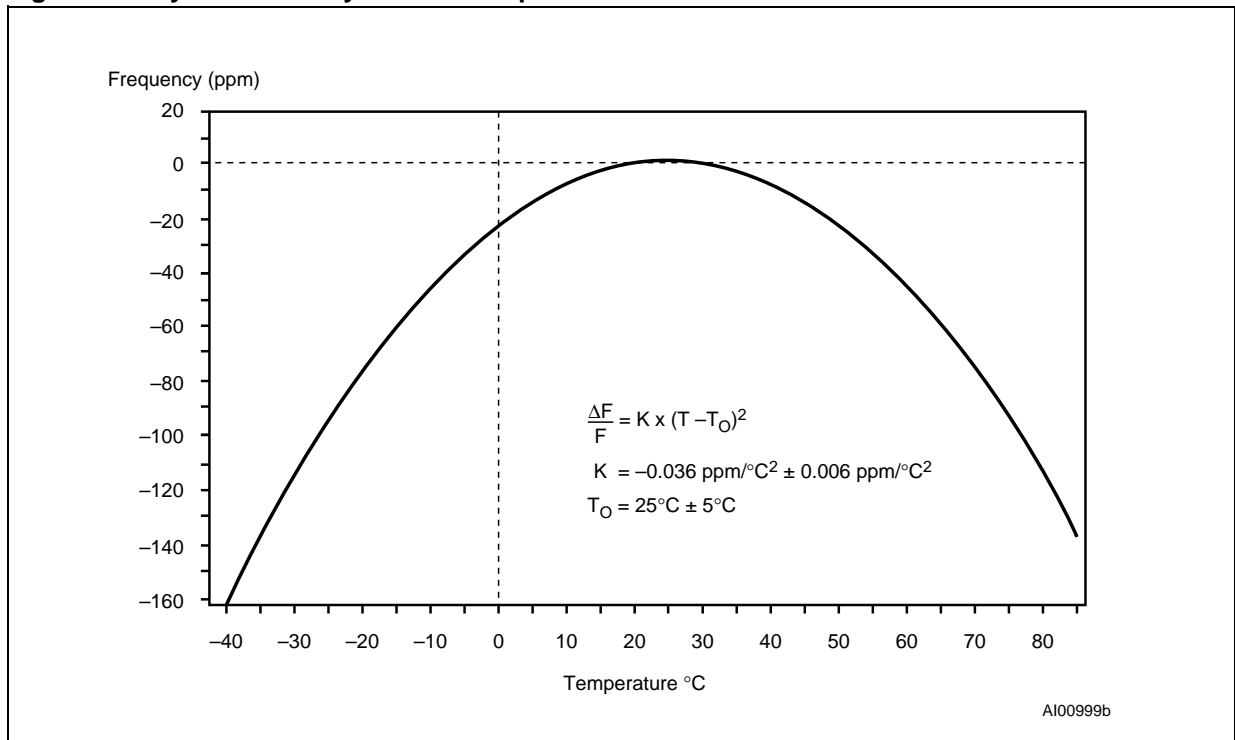
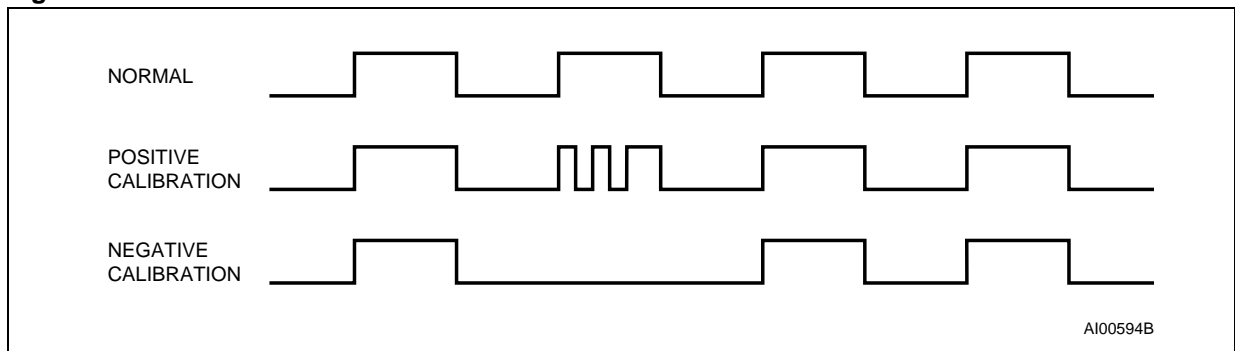

Figure 15. Clock Calibration



Output Driver Pin

When the FT Bit is not set, the FT/OUT pin becomes an output driver that reflects the contents of D7 of the Control Register. In other words, when D6 of location 7 is a '0' and D7 of location 7 is a '0' and then the FT/OUT pin will be driven low.

Note: The FT/OUT pin is open drain which requires an external pull-up resistor.

Initial Power-on Defaults

Upon initial application of power to the device, the FT Bit will be set to a '0' and the OUT Bit will be set to a '1.' All other Register bits will initially power-on in a random state.

MAXIMUM RATING

Stressing the device above the rating listed in the "Absolute Maximum Ratings" table may cause permanent damage to the device. These are stress ratings only and operation of the device at these or any other conditions above those indicated in the Operating sections of this specification is

not implied. Exposure to Absolute Maximum Rating conditions for extended periods may affect device reliability. Refer also to the STMicroelectronics SURE Program and other relevant quality documents.

Table 4. Absolute Maximum Ratings

Symbol	Parameter	Value	Unit
T _A	Ambient Operating Temperature	-40 to 85	°C
T _{STG}	Storage Temperature (V _{CC} Off, Oscillator Off)	SNAPHAT	-40 to 85
		SOIC	-55 to 125
T _{SLD} ^(1,2)	Lead Solder Temperature for 10 seconds	260	°C
V _{IO}	Input or Output Voltages	-0.3 to 7	V
V _{CC}	Supply Voltage	-0.3 to 7	V
I _O	Output Current	20	mA
P _D	Power Dissipation	0.25	W

Note: 1. For SO package, standard (SnPb) lead finish: Reflow at peak temperature of 225°C (total thermal budget not to exceed 180°C for between 90 to 150 seconds).
2. For SO package, Lead-free (Pb-free) lead finish: Reflow at peak temperature of 260°C (total thermal budget not to exceed 245°C for greater than 30 seconds).

CAUTION: Negative undershoots below -0.3V are not allowed on any pin while in the Battery Back-up mode.

CAUTION: Do NOT wave solder SOIC to avoid damaging SNAPHAT sockets.

DC AND AC PARAMETERS

This section summarizes the operating and measurement conditions, as well as the DC and AC characteristics of the device. The parameters in the following DC and AC Characteristic tables are derived from tests performed under the Measure-

ment Conditions listed in the relevant tables. Designers should check that the operating conditions in their projects match the measurement conditions when using the quoted parameters.

Table 5. Operating and AC Measurement Conditions

Parameter	Value	Unit
Supply Voltage (V_{CC})	4.5 to 5.5	V
Ambient Operating Temperature (T_A)	-40 to 85	°C
Load Capacitance (C_L)	100	pF
Input Rise and Fall Times	≤ 5	ns
Input Pulse Voltages	0 to 3	V
Input and Output Timing Ref. Voltages	1.5	V

Note: Output Hi-Z is defined as the point where data is no longer driven.

Figure 16. AC Measurement I/O Waveform

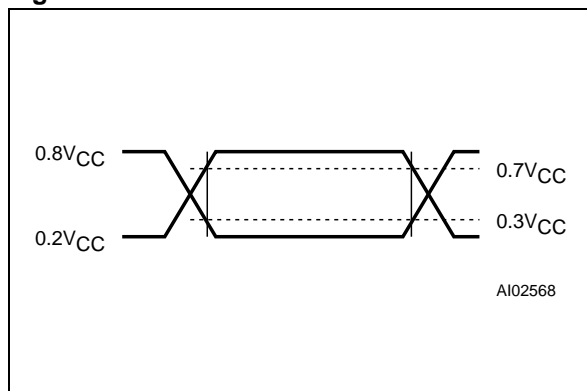

Table 6. Capacitance

Symbol	Parameter ^(1,2)	Min	Max	Unit
C_{IN}	Input Capacitance (SCL)		7	pF
$C_{OUT}^{(3)}$	Output Capacitance (SDA, FT/OUT)		10	pF
t_{LP}	Low-pass filter input time constant (SDA and SCL)	0.25	1	μ s

Note: 1. Effective capacitance measured with power supply at 5V; sampled, not 100% tested.
 2. At 25°C, $f = 1$ MHz.
 3. Outputs deselected.

Table 7. DC Characteristics

Symbol	Parameter	Test Condition ⁽¹⁾	Min	Typ	Max	Unit
I _{LI}	Input Leakage Current	0V ≤ V _{IN} ≤ V _{CC}			±1	μA
I _{LO}	Output Leakage Current	0V ≤ V _{OUT} ≤ V _{CC}			±1	μA
I _{CC1}	Supply Current	Switch Frequency = 100kHz			300	μA
I _{CC2}	Supply Current (Standby)	SCL, SDA = V _{CC} – 0.3V		100		μA
V _{IL}	Input Low Voltage		–0.3		1.5	V
V _{IH}	Input High Voltage		3		V _{CC} + 0.8	V
V _{OL}	Output Low Voltage	I _{OL} = 5mA, V _{CC} = 4.5V			0.4	V
V _{BAT} ⁽²⁾	Battery Supply Voltage		2.5	3	3.5	V
I _{BAT}	Battery Supply Current	T _A = 25°C, V _{CC} = 0V, Oscillator ON, V _{BAT} = 3V		450	550	nA

Note: 1. Valid for Ambient Operating Temperature: T_A = –40 to 85°C; V_{CC} = 4.5 to 5.5V (except where noted).
 2. STMicroelectronics recommends the RAYOVAC BR1225 or BR1632 (or equivalent) as the battery supply.

Table 8. Crystal Electrical Characteristics

Symbol	Parameter ^(1,2,3)	Min	Typ	Max	Unit
f _O	Resonant Frequency		32.768		kHz
R _S	Series Resistance			60	kΩ
C _L	Load Capacitance		12.5		pF

Note: 1. These values are externally supplied if using the SO8 package. STMicroelectronics recommends the KDS DT-38: 1TA/1TC252E127, Tuning Fork Type (thru-hole) or the DMX-26S: 1TJS125FH2A212, (SMD) quartz crystal for industrial temperature operations. KDS can be contacted at kouhou@kdsj.co.jp or http://www.kdsj.co.jp for further information on this crystal type.
 2. Load capacitors are integrated within the M41T56. Circuit board layout considerations for the 32.768 kHz crystal of minimum trace lengths and isolation from RF generating signals should be taken into account.
 3. All SNAPHAT battery/crystal tops meet these specifications.

Figure 17. Power Down/Up Mode AC Waveforms

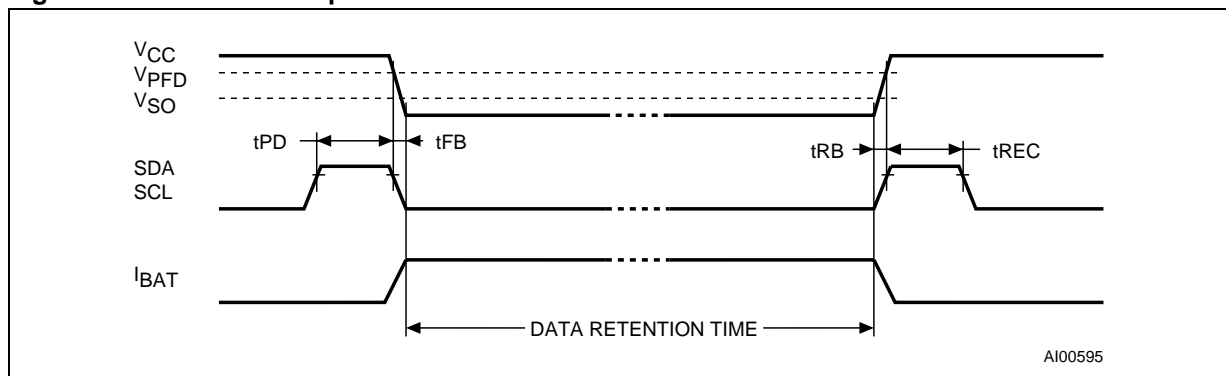

Table 9. Power Down/Up Mode AC Characteristics

Symbol	Parameter ⁽¹⁾	Min	Max	Unit
t_{PD}	SCL and SDA at V_{IH} before Power Down	0		ns
t_{FB}	V_{PFD} (min) to V_{SS} V_{CC} Fall Time	300		μ s
t_{RB}	V_{SS} to V_{PFD} (min) V_{CC} Rise Time	100		μ s
t_{REC}	SCL and SDA at V_{IH} after Power Up	10		μ s

Note: 1. Valid for Ambient Operating Temperature: $T_A = -40$ to 85°C ; $V_{CC} = 4.5$ to 5.5V (except where noted).

Table 10. Power Down/Up Trip Points DC Characteristics

Symbol	Parameter ^(1,2)	Min	Typ	Max	Unit
V_{PFD}	Power-fail Deselect Voltage	$1.2 V_{BAT}$	$1.25 V_{BAT}$	$1.285 V_{BAT}$	V
V_{SO}	Battery Back-up Switchover Voltage		V_{BAT}		V

Note: 1. All voltages referenced to V_{SS} .

2. Valid for Ambient Operating Temperature: $T_A = -40$ to 85°C ; $V_{CC} = 4.5$ to 5.5V (except where noted).

PACKAGE MECHANICAL INFORMATION

Figure 18. SO8 – 8-pin Plastic Small Package Outline

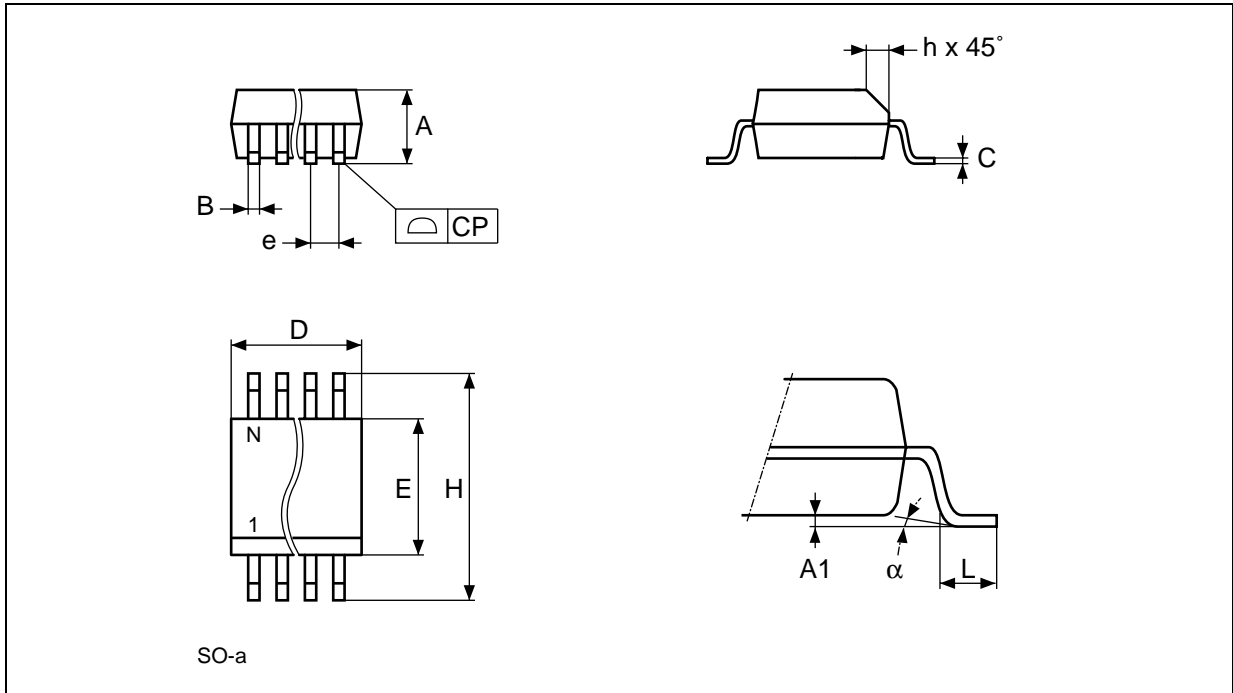

Note: Drawing is not to scale.

Table 11. SO8 – 8-pin Plastic Small Outline, Package Mechanical Data

Symb	mm			inches		
	Typ	Min	Max	Typ	Min	Max
A		1.35	1.75		0.053	0.069
A1		0.10	0.25		0.004	0.010
B		0.33	0.51		0.013	0.020
C		0.19	0.25		0.007	0.010
D		4.80	5.00		0.189	0.197
E		3.80	4.00		0.150	0.157
e	1.27	–	–	0.050	–	–
H		5.80	6.20		0.228	0.244
h		0.25	0.50		0.010	0.020
L		0.40	0.90		0.016	0.035
alpha		0°	8°		0°	8°
N		8			8	
CP			0.10			0.004

Figure 19. SOH28 – 28-lead Plastic Small Outline, 4-socket battery SNAPHAT, Package Outline

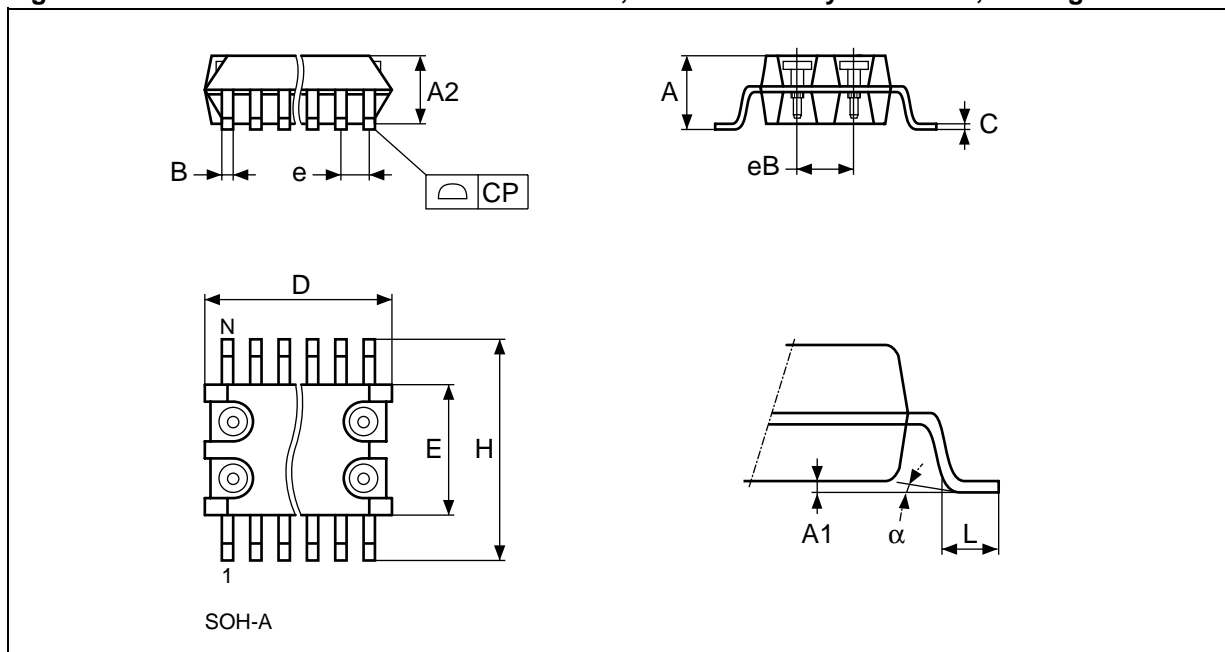

Note: Drawing is not to scale.

Table 12. SOH28 – 28-lead Plastic Small Outline, 4-socket battery SNAPHAT, Mech. Data

Symb	mm			inches		
	Typ	Min	Max	Typ	Min	Max
A			3.05			0.120
A1		0.05	0.36		0.002	0.014
A2		2.34	2.69		0.092	0.106
B		0.36	0.51		0.014	0.020
C		0.15	0.32		0.006	0.012
D		17.71	18.49		0.697	0.728
E		8.23	8.89		0.324	0.350
e	1.27	–	–	0.050	–	–
eB		3.20	3.61		0.126	0.142
H		11.51	12.70		0.453	0.500
L		0.41	1.27		0.016	0.050
alpha		0°	8°		0°	8°
N	28			28		
CP			0.10			0.004

Figure 20. SH – 4-pin SNAPHAT Housing for 48mAh Battery & Crystal, Package Outline

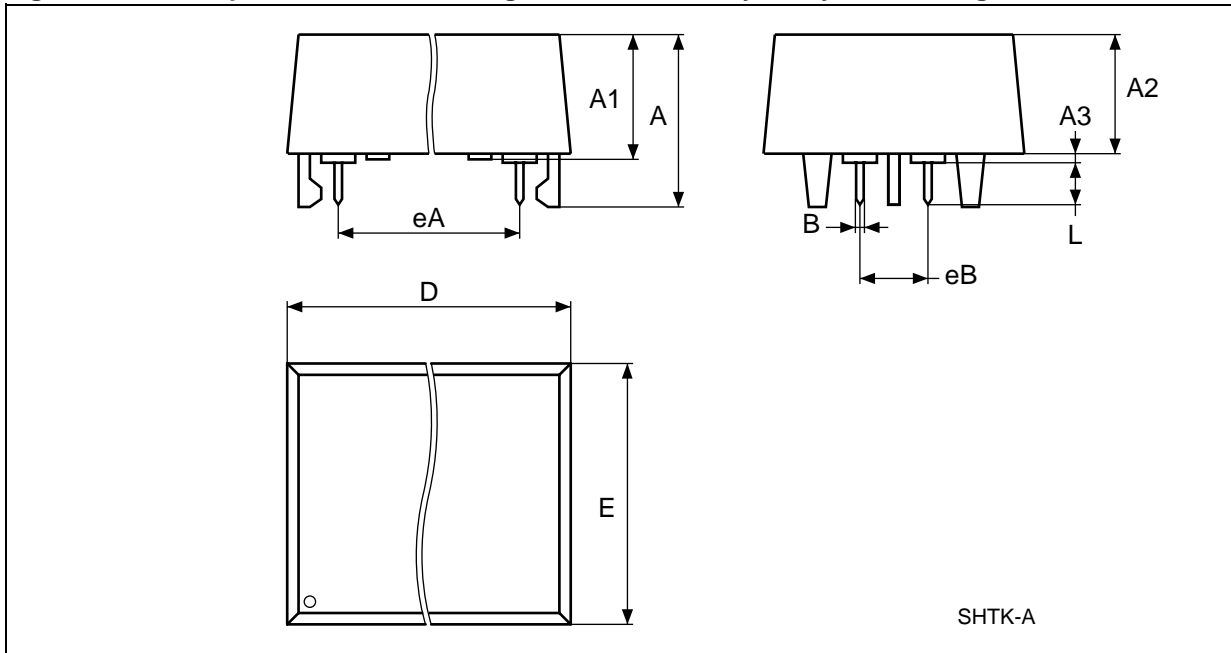

Note: Drawing is not to scale.

Table 13. SH – 4-pin SNAPHAT Housing for 48mAh Battery & Crystal, Package Mech. Data

Symb	mm			inches		
	Typ	Min	Max	Typ	Min	Max
A			9.78			0.385
A1		6.73	7.24		0.265	0.285
A2		6.48	6.99		0.255	0.275
A3			0.38			0.015
B		0.46	0.56		0.018	0.022
D		21.21	21.84		0.835	0.860
E		14.22	14.99		0.560	0.590
eA		15.55	15.95		.6122	.6280
eB		3.20	3.61		0.126	0.142
L		2.03	2.29		0.080	0.090

Figure 21. SH – 4-pin SNAPHAT Housing for 120mAh Battery & Crystal, Package Outline

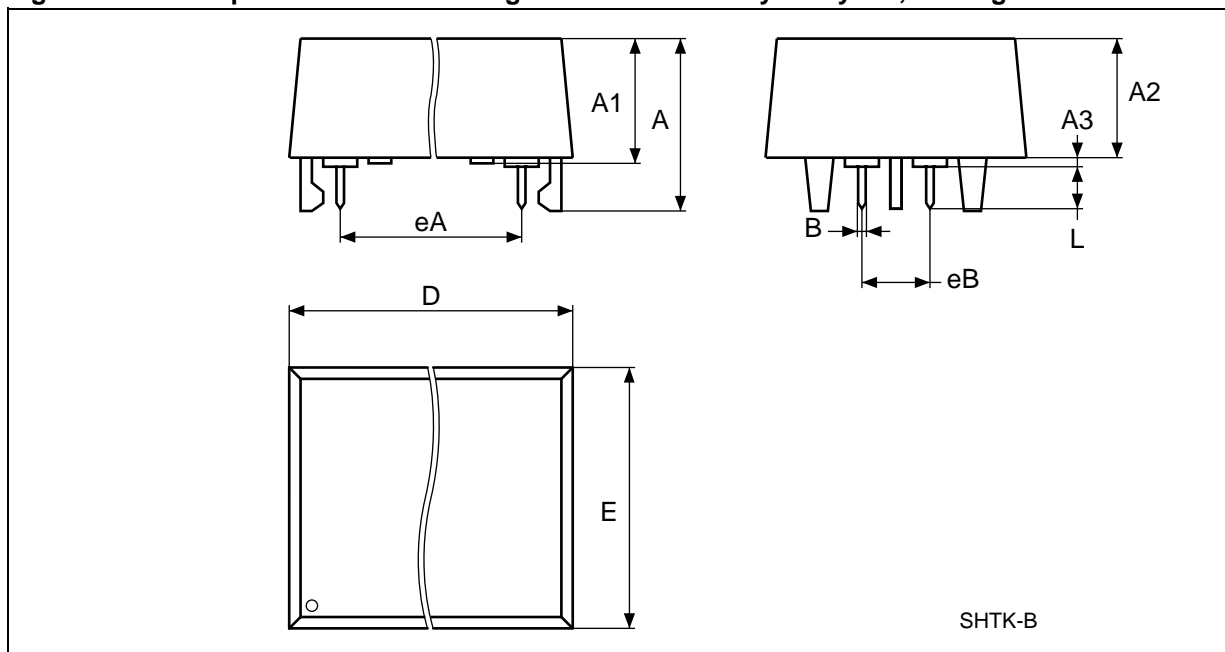

Note: Drawing is not to scale.

Table 14. SH – 4-pin SNAPHAT Housing for 120mAh Battery & Crystal, Package Mech. Data

Symb	mm			inches		
	Typ	Min	Max	Typ	Min	Max
A			10.54			0.415
A1		8.00	8.51		0.315	0.335
A2		7.24	8.00		0.285	0.315
A3			0.38			0.015
B		0.46	0.56		0.018	0.022
D		21.21	21.84		0.835	0.860
E		17.27	18.03		0.680	0.710
eA		15.55	15.95		.6122	.6280
eB		3.20	3.61		0.126	0.142
L		2.03	2.29		0.080	0.090

PART NUMBERING

Table 15. Ordering Information Scheme

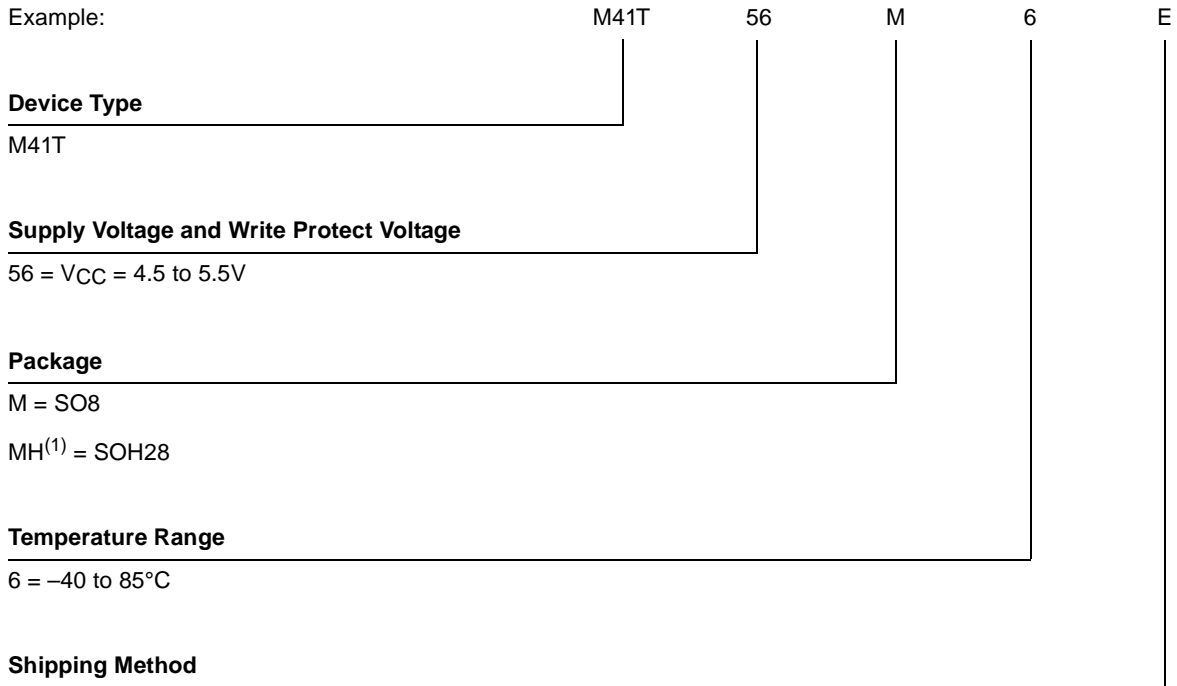

For SO8:

- blank = Tubes (Not for New Design - Use E)
- E = Lead-free Package (ECO[®]PACK[®]), Tubes
- F = Lead-free Package (ECO[®]PACK[®]), Tape & Reel
- TR = Tape & Reel (Not for New Design - Use F)

For SOH28:

- blank = Tubes (Not for New Design - Use E)
- E = Lead-free Package (ECO[®]PACK[®]), Tubes
- F = Lead-free Package (ECO[®]PACK[®]), Tape & Reel
- TR = Tape & Reel (Not for New Design - Use F)

Note: 1. The SOIC package (SOH28) requires the SNAPHAT[®] battery package which is ordered separately under the part number "M4Txx-BR12SHx" in plastic tube or "M4Txx-BR12SHxTR" in Tape & Reel form (see Table 16).

Caution: Do not place the SNAPHAT battery package "M4TXX-BR12SH" in conductive foam as it will drain the lithium button-cell battery.

For other options, or for more information on any aspect of this device, please contact the ST Sales Office nearest you.

Table 16. SNAPHAT Battery/Crystal Table

Part Number	Description	Package
M4T28-BR12SH	Lithium Battery (48mAh)/Crystal SNAPHAT	SH
M4T32-BR12SH	Lithium Battery (120mAh)/Crystal SNAPHAT	SH

REVISION HISTORY

Table 17. Document Revision History

Date	Rev. #	Revision Details
March 1999	1.0	First Issue
12/23/99	1.1	SOH28 package added
03/21/00	1.2	Series Resistance Max Value Changed (Table 8)
11/30/00	1.3	Added PSDIP8 package
01/25/01	1.4	Corrected graphic, measurements of PSDIP8 (Figure 20, Table 14)
02/16/01	2.0	Reformatted, table added (Table 16)
04/06/01	2.1	Add temp./voltage information to characteristics (Tables 7, 2); correct Series Resistance (Table 8)
07/17/01	2.2	Basic formatting changes
08/02/02	2.3	Modify reflow time and temperature footnote (Table 4); modify Crystal Electrical Characteristics table footnotes (Table 8); removed PSDIP8 package
11/07/02	2.4	Correct figure name (Figure 1)
15-Jun-04	3.0	Reformatted; add Lead-free information; update characteristics (Figure 14; Table 4, 15)

Information furnished is believed to be accurate and reliable. However, STMicroelectronics assumes no responsibility for the consequences of use of such information nor for any infringement of patents or other rights of third parties which may result from its use. No license is granted by implication or otherwise under any patent or patent rights of STMicroelectronics. Specifications mentioned in this publication are subject to change without notice. This publication supersedes and replaces all information previously supplied. STMicroelectronics products are not authorized for use as critical components in life support devices or systems without express written approval of STMicroelectronics.

The ST logo is a registered trademark of STMicroelectronics.

All other names are the property of their respective owners.

© 2004 STMicroelectronics - All rights reserved

STMicroelectronics GROUP OF COMPANIES

Australia - Belgium - Brazil - Canada - China - Czech Republic - Finland - France - Germany -
Hong Kong - India - Israel - Italy - Japan - Malaysia - Malta - Morocco - Singapore -
Spain - Sweden - Switzerland - United Kingdom - United States

www.st.com