



# DVCH2800D Series

## HIGH RELIABILITY HYBRID DC-DC CONVERTERS

### DESCRIPTION

The DVCH series of high reliability DC-DC converters is operable over the full military (-55 °C to +125 °C) temperature range with no power derating. Unique to the DVCH series is a magnetic feedback circuit that is radiation immune. Operating at a nominal fixed frequency of 400 kHz, these regulated, isolated units utilize well controlled undervoltage lockout circuitry to eliminate slow start-up problems.

These converters are designed and manufactured in a facility qualified to ISO9001 and certified to MIL-PRF-38534 and MIL-STD-883.

This product may incorporate one or more of the following U.S. patents:

5,784,266  
5,790,389  
5,963,438  
5,999,433  
6,005,780  
6,084,792  
6,118,673

### FEATURES

- High Reliability
- Very Low Output Noise
- Wide Input Voltage Range: 12 to 50 Volts per MIL-STD-704
- Up to 1.5 Watts Output Power
- Radiation Immune Magnetic Feedback Circuit
- NO Use of Optoisolators
- Undervoltage Lockout
- Indefinite Short Circuit Protection
- Current Limit Protection
- Industry Standard Pinout
- High Input Transient Voltage: 80 Volts for 1 sec per MIL-STD-704A
- Precision Projection Welded Hermetic Package
- High Power Density: > 7 W/in<sup>3</sup>
- Custom Versions Available
- Additional Environmental Screening Available
- Meets MIL-STD-461C and MIL-STD-461D EMC Requirements When Used With a DVMSA28 EMI Filter
- MIL-PRF-38534 Element Evaluated Components

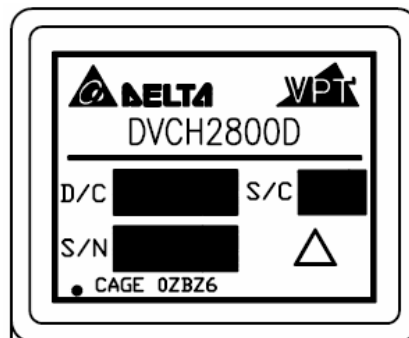


Figure 1 – DVCH2800D DC-DC Converter  
(Not To Scale)

SPECIFICATIONS ( $T_{CASE} = -55^{\circ}\text{C}$  to  $+125^{\circ}\text{C}$ ,  $V_{IN} = +28\text{V} \pm 5\%$ , Full Load, Unless Otherwise Specified)

## ABSOLUTE MAXIMUM RATINGS

Input Voltage (Continuous)	50 $V_{DC}$	Junction Temperature Rise to Case	+5°C
Input Voltage (Transient, 1 second)	80 Volts	Storage Temperature	-65°C to +150°C
Output Power <sup>1</sup>	1.5 Watts	Lead Solder Temperature (10 seconds)	270°C
Power Dissipation (Full Load, $T_{CASE} = +125^{\circ}\text{C}$ )	0.6 Watts	Weight (Maximum)	11 Grams

Parameter	Conditions	DVCH2805D			DVCH2812D			Units
		Min	Typ	Max	Min	Typ	Max	
<b>STATIC</b>								
INPUT Voltage <sup>4</sup>	Continuous	12	28	50	12	28	50	V
	Transient, 1 sec	-	-	80	-	-	80	V
Current	Inhibited	-	-	3.5	-	-	3.5	mA
	No Load	-	-	10	-	-	12	mA
Ripple Current	Full Load, 20Hz to 10MHz	-	-	30	-	-	30	$\text{mA}_{p-p}$
Inhibit Pin Input <sup>4</sup>		0	-	1.5	0	-	1.5	V
Inhibit Pin Open Circuit Voltage <sup>4</sup>		8.0	9.0	11.0	8.0	9.0	11.0	V
UVLO Turn On		6.5	-	11.5	6.5	-	11.5	V
OUTPUT Voltage	$\pm V_{OUT}$ $T_{CASE} = 25^{\circ}\text{C}$	4.95	5.00	5.05	11.88	12.0	12.12	V
	$\pm V_{OUT}$ $T_{CASE} = -55^{\circ}\text{C}$ to $+125^{\circ}\text{C}$	4.80	5.00	5.20	11.52	12.0	12.48	V
Power <sup>3</sup>	Total	0	-	1.5	0	-	1.5	W
	$\pm V_{OUT}$ Either Output	0	-	1.2	0	-	1.2	W
Current <sup>3</sup>	$I_{OUT}$ Either Output	0	-	0.24	0	-	.1	A
	Ripple Voltage	$\pm V_{OUT}$ Full Load, 20Hz to 10MHz	-	-	50	-	-	100
Line Regulation	$\pm V_{OUT}$ $V_{IN} = 12\text{V}$ to $50\text{V}$	-	-	150	-	-	150	mV
Load Regulation	$\pm V_{OUT}$ 10% Load to Full Load	-	-	400	-	-	700	mV
Load Regulation	$\pm V_{OUT}$ 50% Load to Full Load	-	-	250	-	-	250	mV
EFFICIENCY		72	79	-	74	79	-	%
LOAD FAULT POWER DISSIPATION	Overload <sup>4</sup>	-	-	3	-	-	3	W
	Short Circuit	-	-	4	-	-	4.5	W
CAPACITIVE LOAD <sup>4</sup>		-	-	500	-	-	200	$\mu\text{F}$
SWITCHING FREQUENCY		325	400	475	325	400	475	kHz
ISOLATION	500 $V_{DC}$	100	-	-	100	-	-	$\text{M}\Omega$
MTBF (MIL-HDBK-217F)	AIF @ $T_c = 55^{\circ}\text{C}$	-	841	-	-	841	-	kHrs
<b>DYNAMIC</b>								
Load Step Output Transient	$\pm V_{OUT}$ Half Load to Full Load	-	100	300	-	100	300	$\text{mV}_{PK}$
Load Step Recovery <sup>2</sup>		-	200	500	-	100	400	$\mu\text{Sec}$
Line Step Output Transient <sup>4</sup>	$\pm V_{OUT}$ $V_{IN} = 12\text{V}$ to $50\text{V}$	-	200	400	-	300	600	$\text{mV}_{PK}$
Line Step Recovery <sup>2,4</sup>		-	400	600	-	300	600	$\mu\text{Sec}$
Turn On Delay	$\pm V_{OUT}$ $V_{IN} = 0\text{V}$ to $28\text{V}$	-	15	20	-	15	20	mSec
Turn On Overshoot		-	0	25	-	0	50	$\text{mV}_{PK}$

Notes: 1. Dependant on output voltage. 2. Time for output voltage to settle within 1% of its nominal value.  
3. Derate linearly to 0 at 135°C. 4. Verified by qualification testing.

SPECIFICATIONS ( $T_{CASE} = -55^{\circ}\text{C}$  to  $+125^{\circ}\text{C}$ ,  $V_{IN} = +28\text{V} \pm 5\%$ , Full Load, Unless Otherwise Specified)

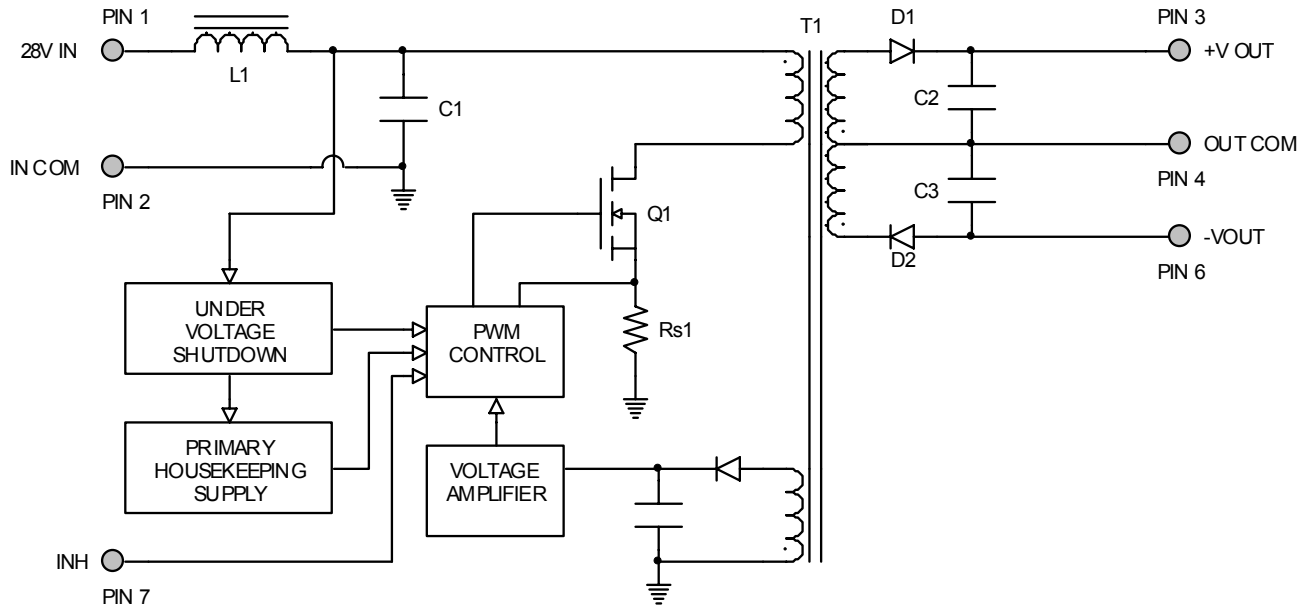
## ABSOLUTE MAXIMUM RATINGS

Input Voltage (Continuous)	50 $V_{DC}$	Junction Temperature Rise to Case	+5°C
Input Voltage (Transient, 1 second)	80 Volts	Storage Temperature	-65°C to +150°C
Output Power <sup>1</sup>	1.5 Watts	Lead Solder Temperature (10 seconds)	270°C
Power Dissipation (Full Load, $T_{CASE} = +125^{\circ}\text{C}$ )	0.6 Watts	Weight (Maximum)	11 Grams

Parameter	Conditions	DVCH2815D			Units
		Min	Typ	Max	
<b>STATIC</b>					
INPUT Voltage <sup>4</sup>	Continuous	12	28	50	V
	Transient, 1 sec	-	-	80	V
Current	Inhibited	-	-	3.5	mA
	No Load	-	-	14	mA
Ripple Current	Full Load, 20Hz to 10MHz	-	-	30	mA <sub>p-p</sub>
Inhibit Pin Input <sup>4</sup>		0	-	1.5	V
Inhibit Pin Open Circuit Voltage <sup>4</sup>		8.0	9.0	11.0	V
UVLO Turn On		6.5	-	11.5	V
OUTPUT Voltage	$\pm V_{OUT}$ $T_{CASE} = 25^{\circ}\text{C}$	14.85	15.0	15.15	V
	$\pm V_{OUT}$ $T_{CASE} = -55^{\circ}\text{C}$ to $+125^{\circ}\text{C}$	14.40	15.0	15.60	V
Power <sup>3</sup>	Total	0	-	1.5	W
	$\pm V_{OUT}$ Either Output	0	-	1.2	W
Current <sup>3</sup>	$I_{OUT}$ Either Output	0	-	0.08	A
Ripple Voltage	$\pm V_{OUT}$ Full Load, 20Hz to 10MHz	-	-	100	mV <sub>p-p</sub>
Line Regulation	$\pm V_{OUT}$ $V_{IN} = 12\text{V}$ to $50\text{V}$	-	-	150	mV
Load Regulation	$\pm V_{OUT}$ 10% Load to Full Load	-	-	700	mV
Load Regulation	$\pm V_{OUT}$ 50% Load to Full Load	-	-	250	mV
EFFICIENCY		74	79	-	%
LOAD FAULT POWER DISSIPATION	Overload <sup>4</sup>	-	-	3	W
	Short Circuit	-	-	4.5	W
CAPACITIVE LOAD <sup>4</sup>		-	-	200	$\mu\text{F}$
SWITCHING FREQUENCY		325	400	475	kHz
ISOLATION	500 $V_{DC}$	100	-	-	M $\Omega$
MTBF (MIL-HDBK-217F)	AIF @ $T_c = 55^{\circ}\text{C}$	-	841	-	kHrs
<b>DYNAMIC</b>					
Load Step Output Transient	$\pm V_{OUT}$ Half Load to Full Load	-	100	300	mV <sub>PK</sub>
Load Step Recovery <sup>2</sup>		-	100	400	$\mu\text{Sec}$
Line Step Output Transient <sup>4</sup>	$\pm V_{OUT}$ $V_{IN} = 12\text{V}$ to $50\text{V}$	-	300	600	mV <sub>PK</sub>
Line Step Recovery <sup>2,4</sup>		-	300	600	$\mu\text{Sec}$
Turn On Delay	$\pm V_{OUT}$ $V_{IN} = 0\text{V}$ to $28\text{V}$	-	15	20	mSec
Turn On Overshoot		-	0	50	mV <sub>PK</sub>

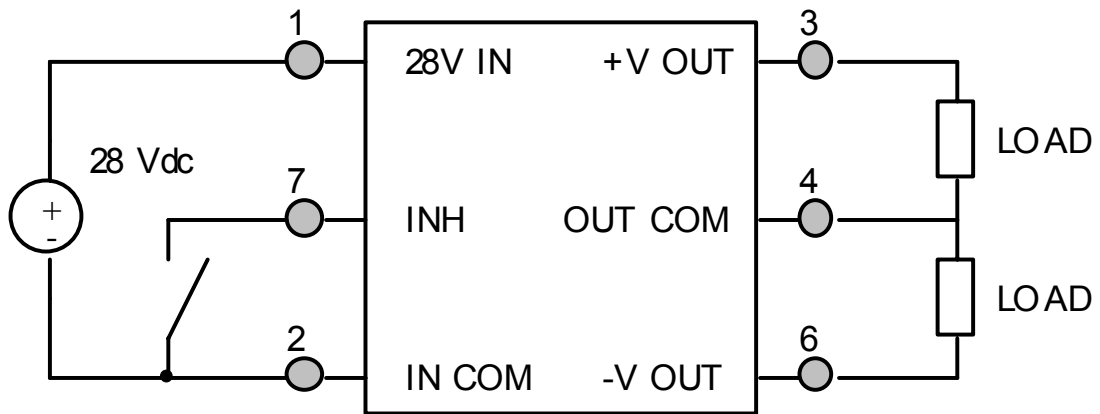
Notes: 1. Dependant on output voltage. 2. Time for output voltage to settle within 1% of its nominal value.  
3. Derate linearly to 0 at 135°C. 4. Verified by qualification testing.

**BLOCK DIAGRAM**



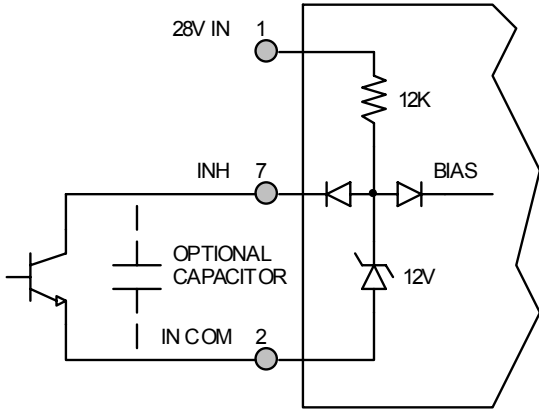
**Figure 2**

**CONNECTION DIAGRAM**

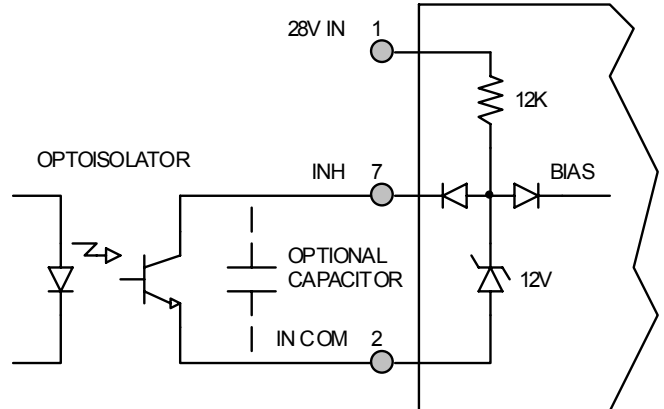


**Figure 3**

**INHIBIT DRIVE CONNECTION DIAGRAMS**

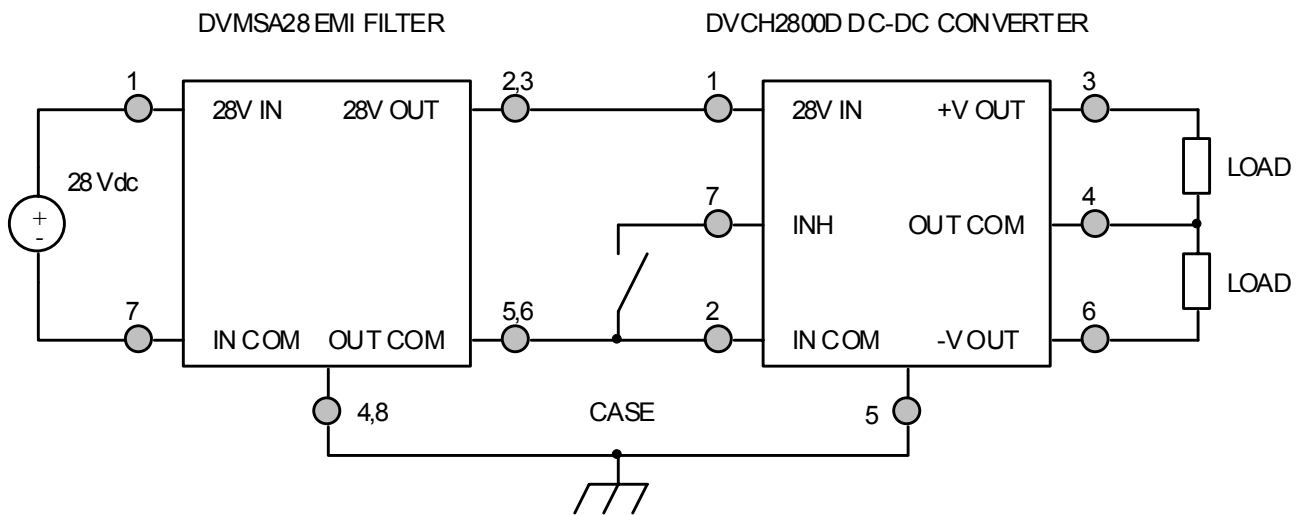


**Figure 4** – Internal Inhibit Circuit and Recommended Drive  
(Shown with optional capacitor for turn-on delay)



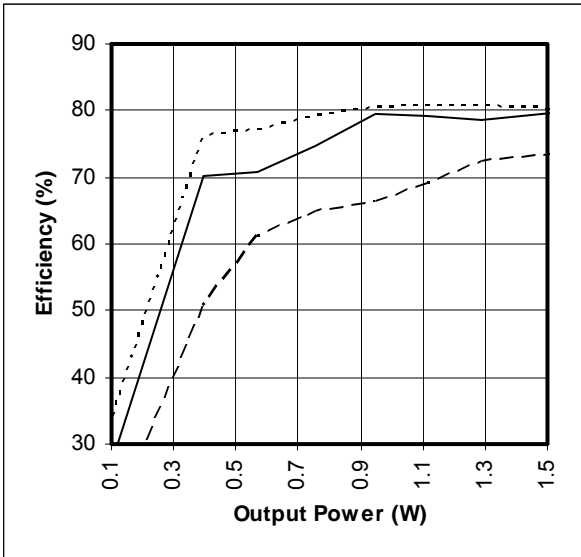
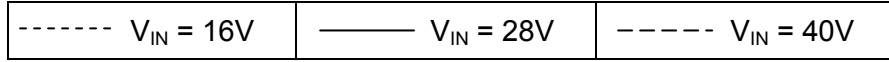
**Figure 5** – Isolated Inhibit Drive  
(Shown with optional capacitor for turn-on delay)

**EMI FILTER HOOKUP DIAGRAM**

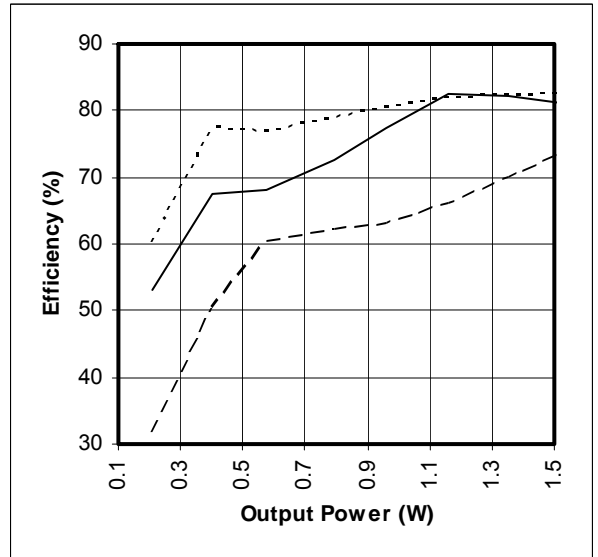


**Figure 6** – Converter with EMI Filter

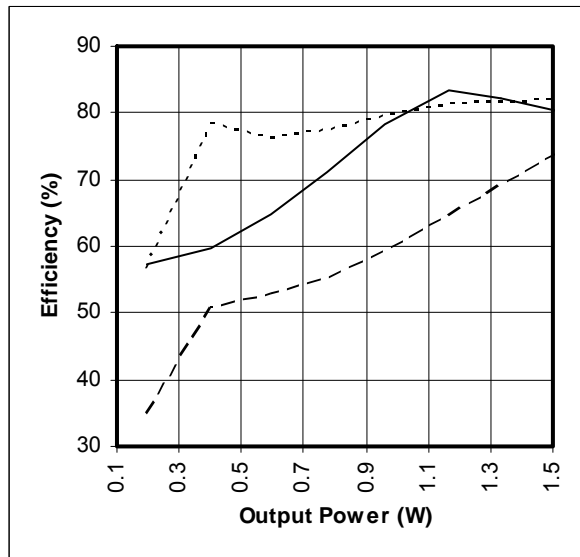
EFFICIENCY PERFORMANCE CURVES ( $T_{CASE} = 25^{\circ}C$ , Full Load, Unless Otherwise Specified)



**Figure 7 – DVCH2805D**  
Efficiency (%) vs. Output Power (W)



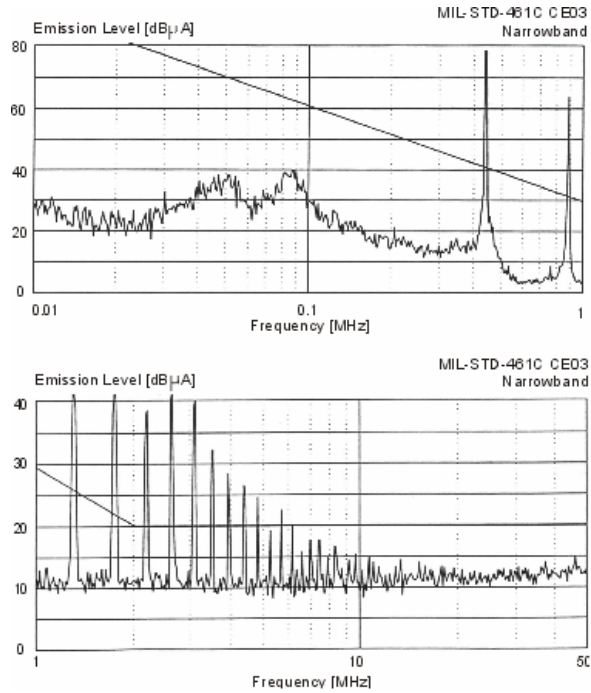
**Figure 8 – DVCH2812D**  
Efficiency (%) vs. Output Power (W)



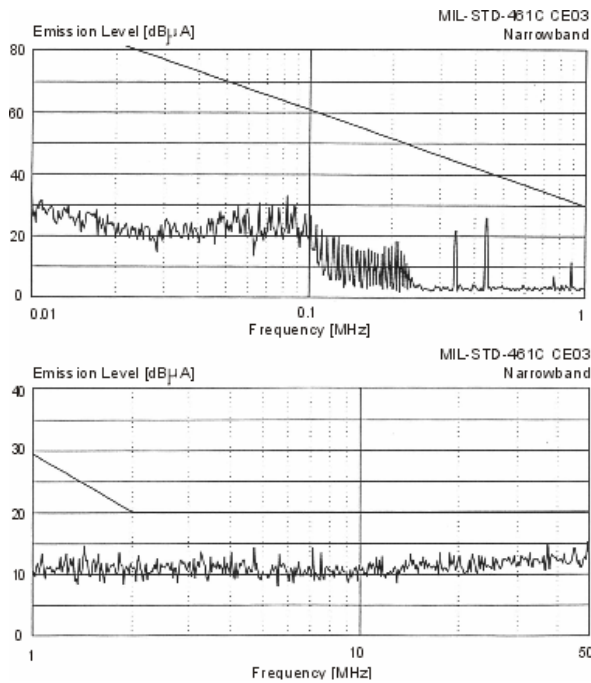
**Figure 9 – DVCH2815D**  
Efficiency (%) vs. Output Power (W)

**EMI PERFORMANCE CURVES**

( $T_{CASE} = 25^{\circ}C$ ,  $V_{IN} = +28V \pm 5\%$ , Full Load, Unless Otherwise Specified)

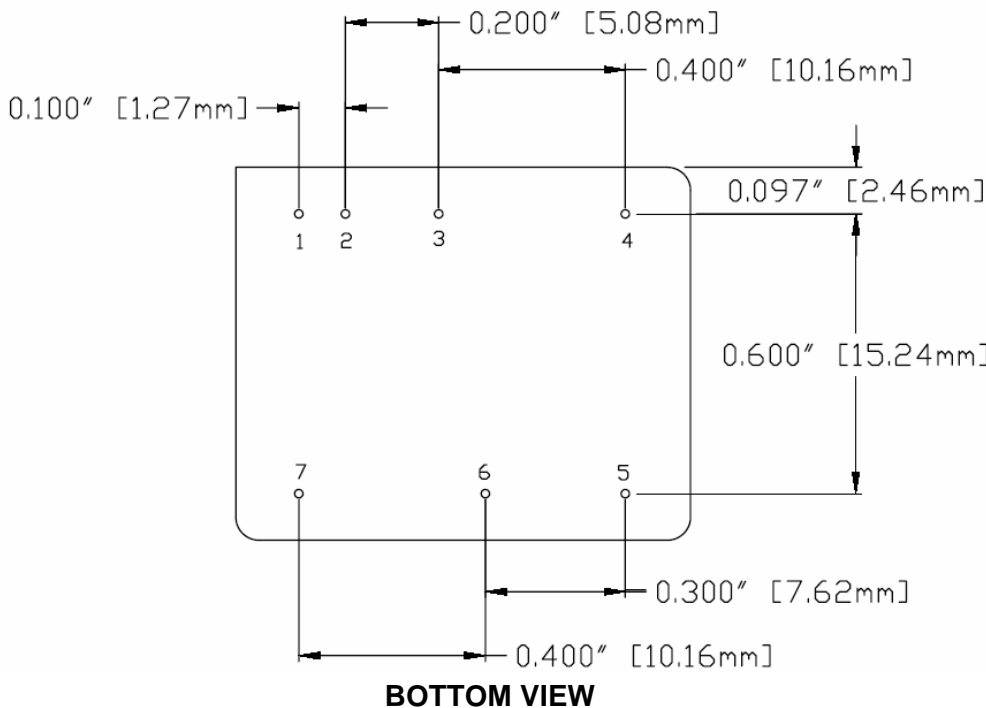
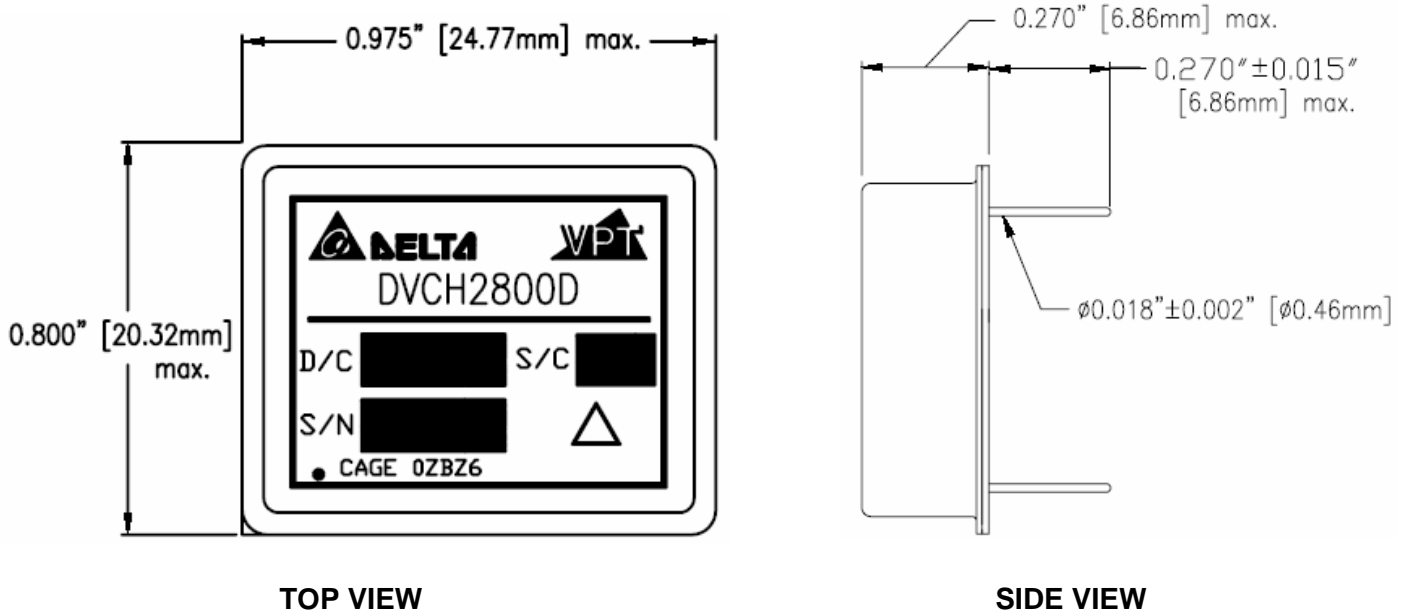


**Figure 10 – DVCH2800D without EMI Filter**



**Figure 11 – DVCH2800D with EMI Filter**

## PACKAGE SPECIFICATIONS



PIN	FUNCTION
1	28V IN
2	IN COM
3	+V OUT
4	OUT COM
5	CASE
6	-V OUT
7	INHIBIT

**Figure 12 – Package and Pinout**  
 (Dimensional Limits are ±0.005" Unless Otherwise Stated)



## PACKAGE PIN DESCRIPTION

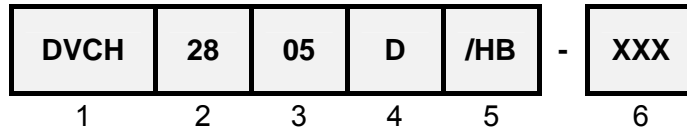
Pin	Function	Description
1	28V IN	Positive Input Voltage Connection
2	IN COM	Input Common Connection
3	+V OUT	Positive Output Voltage Connection
4	OUT COM	Output Common Connection
5	CASE	Case Connection
6	-V OUT	Negative Output Voltage Connection
7	INHIBIT	Logic Low = Disabled Output. Connecting the inhibit pin to input common causes converter shutdown. Logic High = Enabled Output. Unconnected or open collector TTL.

## ENVIRONMENTAL SCREENING (100% Tested Per MIL-STD-883 as referenced to MIL-PRF-38534)

Screening	MIL-STD-883	Standard (No Suffix)	Extended /ES	HB /HB	Class H /H	Class K /K
Non-Destructive Bond Pull	Method 2023	•	•	•	•	•
Internal Visual	Method 2017, 2032 Internal Procedure	•	•	•	•	•
Temperature Cycling	Method 1010, Condition C Method 1010, -55°C to 125°C		•	•	•	•
Constant Acceleration	Method 2001, 3000g, Y1 Direction Method 2001, 500g, Y1 Direction		•	•	•	•
PIND	Method 2020, Condition A <sup>2</sup>					•
Pre Burn-In Electrical	100% at 25°C					•
Burn-In	Method 1015, 320 hours at +125°C Method 1015, 160 hours at +125°C 96 hours at +125°C 24 hours at +125°C	•	•	•	•	•
Final Electrical	MIL-PRF-38534, Group A <sup>1</sup> 100% at 25°C	•	•	•	•	•
Hermeticity	Method 1014, Fine Leak, Condition A Method 1014, Gross Leak, Condition C Dip (1 x 10 <sup>-3</sup> )	•	•	•	•	•
Radiography	Method 2012 <sup>3</sup>					•
External Visual	Method 2009	•	•	•	•	•

- Notes:
1. 100% R&R testing at -55°C, +25°C, and +125°C with all test data included in product shipment.
  2. PIND test Certificate of Compliance included in product shipment.
  3. Radiographic test Certificate of Compliance and film(s) included in product shipment.

## ORDERING INFORMATION



(1)

(2)

(3)

(4)

Product Series	Nominal Input Voltage		Output Voltage		Number of Outputs	
<b>DVCH</b>	<b>28</b>	28 Volts	<b>05</b> <b>12</b> <b>15</b>	5 Volts 12 Volts 15 Volts	<b>D</b>	Dual

(5)

(6)

Screening Code <sup>1,2</sup>		Additional Screening Code
<b>None</b> <b>/ES</b> <b>/HB</b> <b>/H</b> <b>/K</b>	Standard Extended HB Class H Class K	Contact Sales

- Notes:
1. Contact the VPT Inc. Sales Department for availability of Class H (/H) or Class K (/K) qualified products.
  2. VPT Inc. reserves the right to ship higher screened or SMD products to meet lower screened orders at our sole discretion unless specifically forbidden by customer contract.

Please contact your sales representative or the VPT Inc. Sales Department for more information concerning additional environmental screening and testing, different input voltage, output voltage, power requirement, source inspection, and/or special element evaluation for space or other higher quality applications.

## SMD (STANDARD MICROCIRCUIT DRAWING) NUMBERS

Standard Microcircuit Drawing (SMD)	DVCH2800D Series Similar Part Number
*T.B.D.	DVCH2805D/H
*T.B.D.	DVCH2812D/H
*T.B.D.	DVCH2815D/H

Do not use the DVCH2800D Series similar part number for SMD product acquisition. It is listed for reference only. For exact specifications for the SMD product, refer to the SMD drawing. SMD's can be downloaded from the DSCC website at <http://www.dscclia.mil/programs/smcr/>. The SMD number listed above is for MIL-PRF-38534 Class H screening, standard gold plated lead finish, and no RHA (Radiation Hardness Assurance) level. Please reference the SMD for other screening levels, lead finishes, and radiation levels.

## CONTACT INFORMATION

To request a quotation or place orders please contact your sales representative or the VPT Inc. Sales Department at:

**Phone:** (425) 353-3010  
**Fax:** (425) 353-4030  
**E-mail:** [vptsales@vpt-inc.com](mailto:vptsales@vpt-inc.com)

All information contained in this datasheet is believed to be accurate, however, no responsibility is assumed for possible errors or omissions. The products or specifications contained herein are subject to change without notice.