

POWER MANAGEMENT
Description

The EZ1084 series of high performance positive voltage regulators are designed for use in applications requiring low dropout performance at up to 5A. Additionally, the EZ1084 series provides excellent regulation over variations in line, load and temperature.

Outstanding features include low dropout performance at rated current, fast transient response, internal current limiting and thermal shutdown protection of the output device.

A variety of options are available for maximum flexibility: the EZ1084C has both fixed and adjustable voltage options and is designed for use in commercial applications; the EZ1084BC is adjustable only for cost sensitive commercial applications; the EZ1084I is adjustable only for industrial applications.

All devices are available in the popular TO-220 and TO-263 packages.

Features

- ◆ Low dropout voltage: 1.3V max. for EZ1084C, 1.4V max. for EZ1084I, 1.45V max. for EZ1084BC
- ◆ Full current rating over line and temperature
- ◆ Fast transient response
- ◆ ±2% total output regulation over line, load and temperature (±2.4% for EZ1084BC)
- ◆ Adjust pin current max 90µA over temperature
- ◆ Fixed/adjustable output voltage (EZ1084C)
- ◆ Line regulation typically 0.015%
- ◆ Load regulation typically 0.05%
- ◆ Industrial temperature range (EZ1084I)
- ◆ TO-220 and TO-263 packages

Applications

- ◆ Printer and plotter supplies
- ◆ Instrumentation
- ◆ Medical equipment
- ◆ Microcontroller systems
- ◆ Telecommunication systems
- ◆ Motherboards
- ◆ Switching supply post regulation

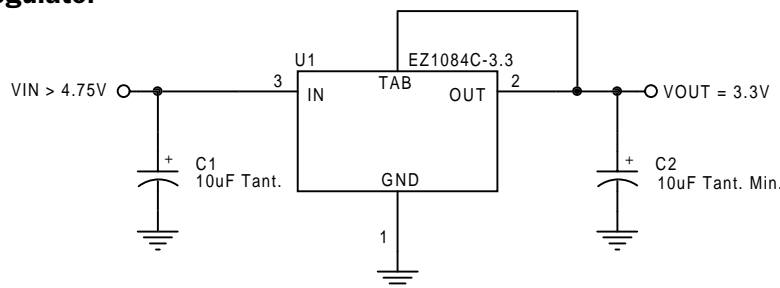
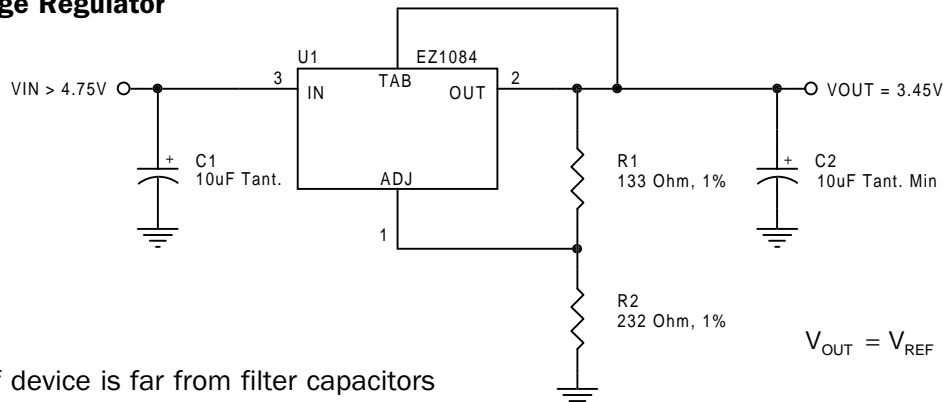
Typical Application Circuit
Fixed Voltage Regulator

Adjustable Voltage Regulator

Notes:

- (1) C1 needed if device is far from filter capacitors
- (2) C2 minimum value required for stability

$$V_{OUT} = V_{REF} \cdot \left(1 + \frac{R2}{R1}\right) + I_{ADJ} \cdot R2$$

POWER MANAGEMENT

Absolute Maximum Ratings

Parameter	Symbol	Maximum	Units
Input Supply Voltage	V_{IN}	7	V
Power Dissipation	P_D	Internally Limited	W
Thermal Resistance Junction to Case TO-220 TO-263	θ_{JC}	2.5 2.5	°C/W
Thermal Resistance Junction to Ambient TO-220 TO-263	θ_{JA}	50 60	°C/W
Operating Ambient Temperature Range EZ1084BC, EZ1084C EZ1084I	T_A	0 to 70 -40 to 85	°C
Operating Junction Temperature Range EZ1084BC, EZ1084C EZ1084I	T_J	0 to 125 -40 to 125	°C
Storage Temperature Range	T_{STG}	-65 to 150	°C
Lead Temperature (Soldering) 10 Sec.	T_{LEAD}	300	°C
ESD Rating (Human Body Model)	ESD	2	kV

Electrical Characteristics

Unless otherwise specified: Adj. V_{IN} = 2.75V to 7.0V and Adj. I_O = 10mA to 5A; Fixed V_{IN} = 4.75 to 7.0V and Fixed I_O = 0 mA to 5A.
Values in **bold** apply over full operating ambient temperature range.

Parameter	Symbol	V_{IN}	I_O	Min	Typ	Max	Units
Output Voltage ⁽¹⁾ EZ1084C-X.X	V_O	5V	0mA	0.99 V_O	V_O	1.01 V_O 1.02V_O	V
Reference Voltage ⁽¹⁾ EZ1084C, EZ1084I	V_{REF}	5V	10mA	1.238 1.225	1.250	1.262 1.275	V
Reference Voltage ⁽¹⁾ EZ1084BC	V_{RE}	5V	10mA	1.233 1.220	1.250	1.267 1.280	V
Line Regulation ⁽¹⁾	$REG_{(LINE)}$		10mA		0.045	0.2	%
Load Regulation ⁽¹⁾	$REG_{(LOAD)}$	5V			0.15	0.4	%
Dropout Voltage ⁽¹⁾⁽²⁾ EZ1084C, EZ1084C-X.X EZ1084I EZ1084BC	V_D		5A		1.20 1.20 1.20	1.30 1.40 1.45	V
Current Limit	I_{CL}			5.0	7.5		A

POWER MANAGEMENT
Electrical Characteristics (Cont)

Unless otherwise specified: Adj. $V_{IN} = 2.75V$ to $7.0V$ and Adj. $I_O = 10mA$ to $5A$; Fixed $V_{IN} = 4.75$ to $7.0V$ and Fixed $I_O = 0$ mA to $5A$.
Values in **bold** apply over full operating ambient temperature range.

Parameter	Symbol	V_{IN}	I_O	Min	Typ	Max	Units
Quiescent Current Fixed Voltage Version	I_Q	5V			10	14	mA
Temperature Coefficient	T_C				0.005		%/°C
Adjust Pin Current	I_{ADJ}				55	90	μA
Adjust Pin Current Change	ΔI_{ADJ}				0.2	5	μA
Temperature Stability	T_S	5V	0.5A		0.5		%
Minimum Load Current Adj Voltage Versions	I_O	5V			5	10	mA
RMS Output Noise ⁽³⁾	V_N				0.003		% V_O
Ripple Rejection Ratio ⁽⁴⁾	R_A	5V	5A	60	72		dB

NOTES:

- (1) Low duty cycle pulse testing with Kelvin connections required.
- (2) $\Delta V_{OUT}, \Delta V_{REF} = 1\%$
- (3) Bandwidth of 10 Hz to 10 kHz.
- (4) 120 Hz input ripple (C_{ADJ} for ADJ = $25\mu F$).

POWER MANAGEMENT

Pin Configurations

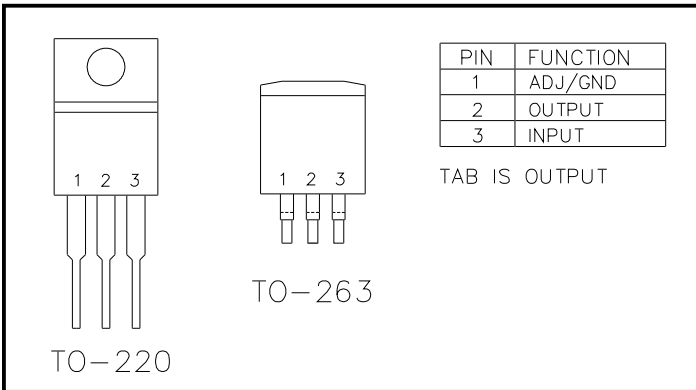

Ordering Information

Device ⁽¹⁾⁽²⁾	Package
EZ1084BCM.TR EZ1084CM-X.X.TR EZ1084IM.TR	TO-263 ⁽³⁾
EZ1084BCT EZ1084CT-X.X EZ1084IT	TO-220 ⁽⁴⁾

Notes:

- (1) Where X.X denotes voltage options (EZ1084C only). Available voltages are: 1.5V, 2.5V and 3.3V. Leave blank for adjustable version (1.3 to 5.7V). Contact factory for additional voltage options.
- (2) Where C and I denote Commercial (0°C to 70°C) and Industrial (-40°C to 85°C) ambient temperature ranges.
- (3) Only available in tape and reel packaging. A reel contains 800 devices.
- (4) Only available in tube packaging. A tube contains 50 devices.

Pin Descriptions

Pin	Pin Name	Pin Function
1	ADJUST	This pin is the negative side of the reference voltage for adjustable devices. Transient response can be improved by adding a small bypass capacitor from the adjust pin to ground.
	GROUND	This pin is the bottom end of the internal resistor feedback chain for fixed output voltage parts, and should be connected to ground.
2	OUTPUT	This is the power output of the device and is electrically connected to the TAB.
3	INPUT	This is the input supply pin for both the control circuitry and the pass device.

Block Diagram

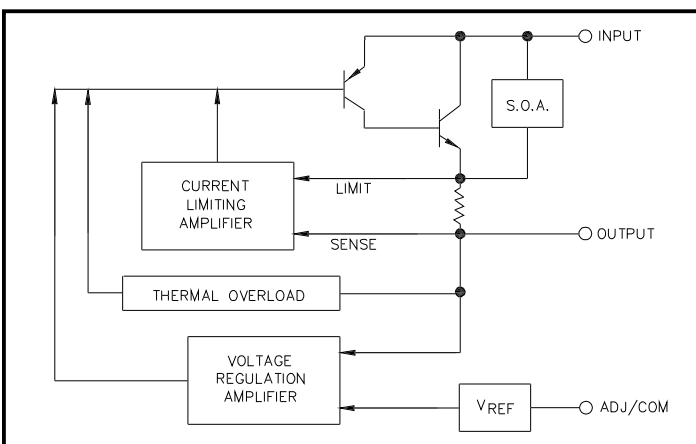

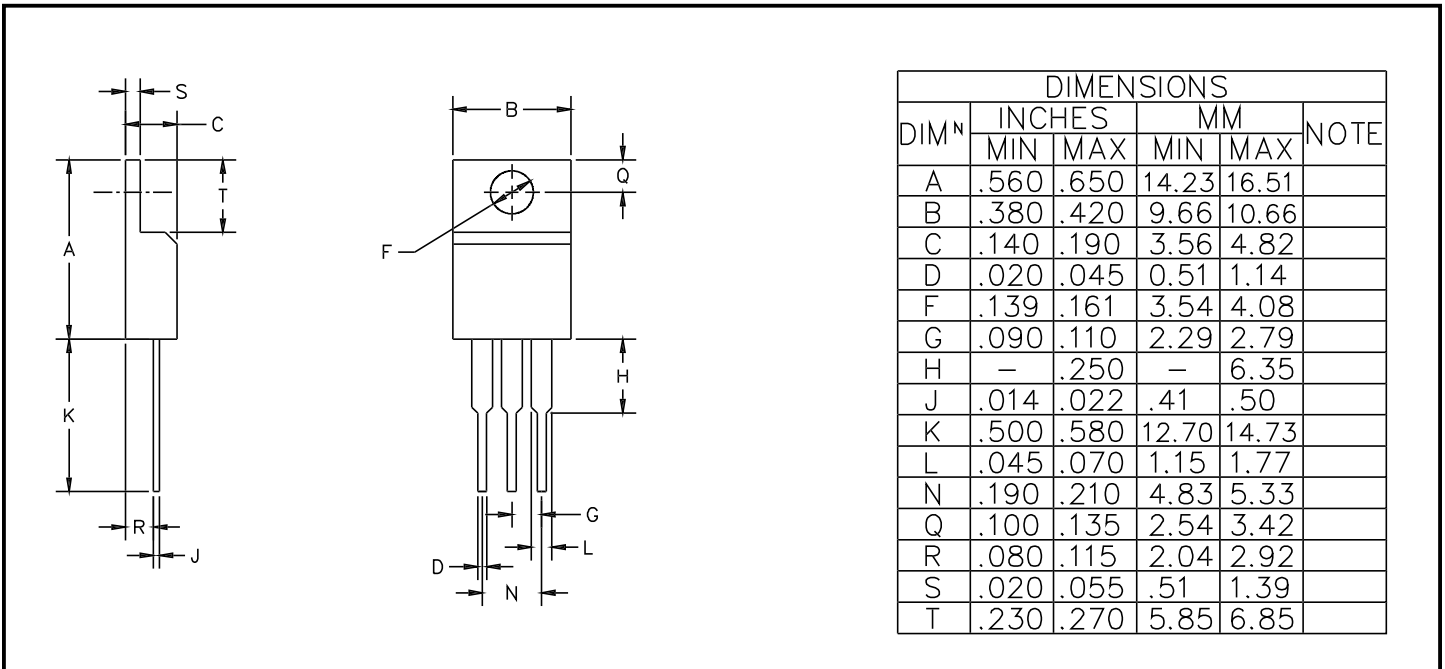
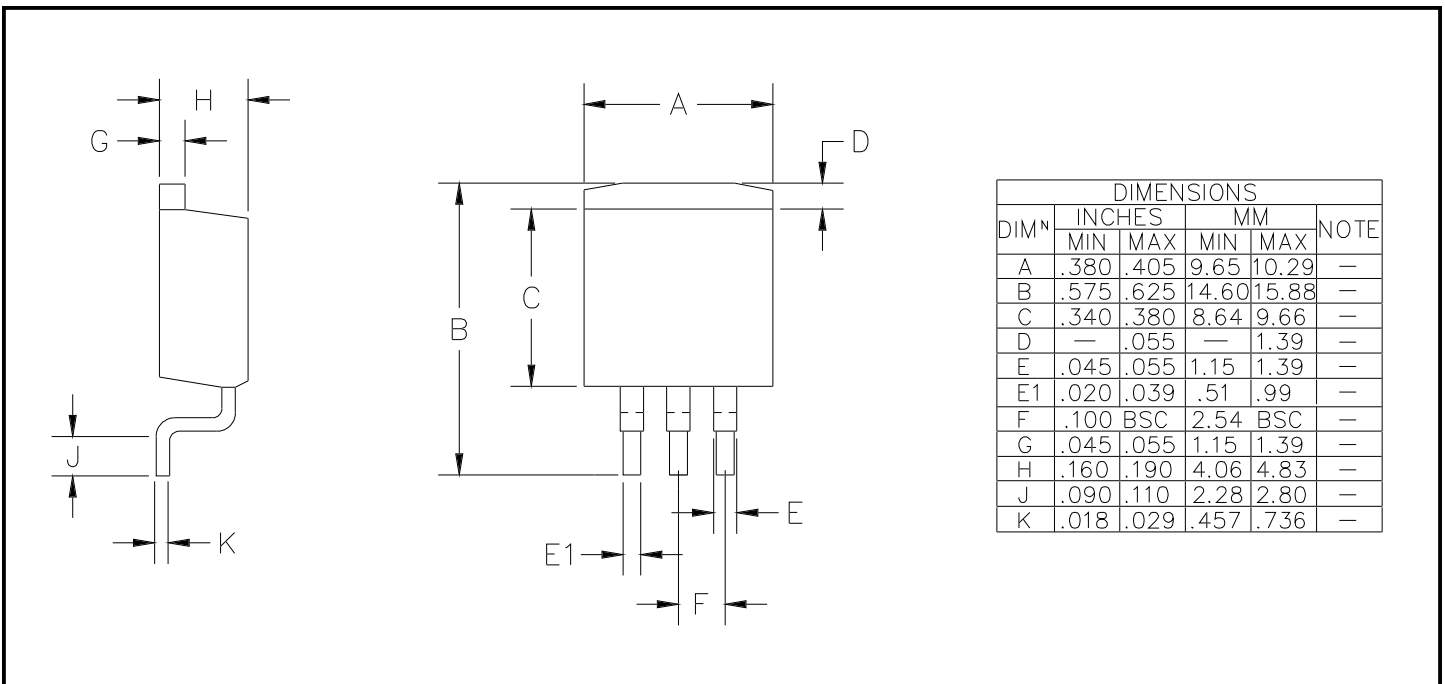
POWER MANAGEMENT
Outline Drawing - TO-220

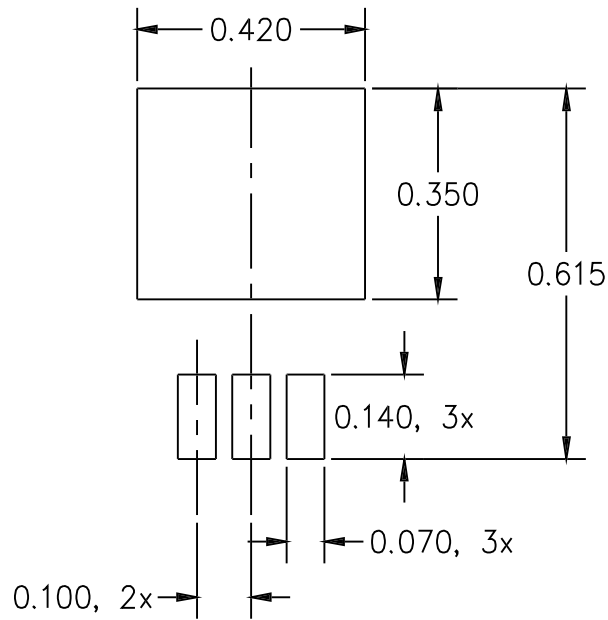
Outline Drawing - TO-263

POWER MANAGEMENT**Land Pattern - TO-263**

NOTE: ALL DIMENSIONS ARE IN INCHES

Contact Information

Semtech Corporation
Power Management Products Division
652 Mitchell Rd., Newbury Park, CA 91320
Phone: (805)498-2111 FAX (805)498-3804