

To all our customers

Regarding the change of names mentioned in the document, such as Hitachi Electric and Hitachi XX, to Renesas Technology Corp.

The semiconductor operations of Mitsubishi Electric and Hitachi were transferred to Renesas Technology Corporation on April 1st 2003. These operations include microcomputer, logic, analog and discrete devices, and memory chips other than DRAMs (flash memory, SRAMs etc.) Accordingly, although Hitachi, Hitachi, Ltd., Hitachi Semiconductors, and other Hitachi brand names are mentioned in the document, these names have in fact all been changed to Renesas Technology Corp. Thank you for your understanding. Except for our corporate trademark, logo and corporate statement, no changes whatsoever have been made to the contents of the document, and these changes do not constitute any alteration to the contents of the document itself.

Renesas Technology Home Page: <http://www.renesas.com>

Renesas Technology Corp.
Customer Support Dept.
April 1, 2003

Cautions

Keep safety first in your circuit designs!

1. Renesas Technology Corporation puts the maximum effort into making semiconductor products better and more reliable, but there is always the possibility that trouble may occur with them. Trouble with semiconductors may lead to personal injury, fire or property damage.

Remember to give due consideration to safety when making your circuit designs, with appropriate measures such as (i) placement of substitutive, auxiliary circuits, (ii) use of nonflammable material or (iii) prevention against any malfunction or mishap.

Notes regarding these materials

1. These materials are intended as a reference to assist our customers in the selection of the Renesas Technology Corporation product best suited to the customer's application; they do not convey any license under any intellectual property rights, or any other rights, belonging to Renesas Technology Corporation or a third party.
2. Renesas Technology Corporation assumes no responsibility for any damage, or infringement of any third-party's rights, originating in the use of any product data, diagrams, charts, programs, algorithms, or circuit application examples contained in these materials.
3. All information contained in these materials, including product data, diagrams, charts, programs and algorithms represents information on products at the time of publication of these materials, and are subject to change by Renesas Technology Corporation without notice due to product improvements or other reasons. It is therefore recommended that customers contact Renesas Technology Corporation or an authorized Renesas Technology Corporation product distributor for the latest product information before purchasing a product listed herein.
The information described here may contain technical inaccuracies or typographical errors. Renesas Technology Corporation assumes no responsibility for any damage, liability, or other loss rising from these inaccuracies or errors.
Please also pay attention to information published by Renesas Technology Corporation by various means, including the Renesas Technology Corporation Semiconductor home page (<http://www.renesas.com>).
4. When using any or all of the information contained in these materials, including product data, diagrams, charts, programs, and algorithms, please be sure to evaluate all information as a total system before making a final decision on the applicability of the information and products. Renesas Technology Corporation assumes no responsibility for any damage, liability or other loss resulting from the information contained herein.
5. Renesas Technology Corporation semiconductors are not designed or manufactured for use in a device or system that is used under circumstances in which human life is potentially at stake. Please contact Renesas Technology Corporation or an authorized Renesas Technology Corporation product distributor when considering the use of a product contained herein for any specific purposes, such as apparatus or systems for transportation, vehicular, medical, aerospace, nuclear, or undersea repeater use.
6. The prior written approval of Renesas Technology Corporation is necessary to reprint or reproduce in whole or in part these materials.
7. If these products or technologies are subject to the Japanese export control restrictions, they must be exported under a license from the Japanese government and cannot be imported into a country other than the approved destination.
Any diversion or reexport contrary to the export control laws and regulations of Japan and/or the country of destination is prohibited.
8. Please contact Renesas Technology Corporation for further details on these materials or the products contained therein.

HA16103 FPJ/FPK

Watchdog Timer



ADE-204-010B (Z)
Rev. 2
Dec. 2000

Description

The HA16103FPJ/FPK monolithic voltage control is designed for microcomputer systems. In addition to voltage regulator, it includes watch dog timer function, power on reset function, and output voltage monitor function.

It is suitable for battery use microcomputer systems.

Functions

- 5 V regulated power supply
- Power on reset pulse generator
- Watch dog timer
- Low voltage inhibit protection

Features

- Wide operational supply voltage range ($V_{CC} = 6$ to 40 V)
- Various control signals are generated when microcomputer system runaway occurs. (\overline{NMI} signal and \overline{STBY} signal are generated by detecting voltage level, and \overline{RES} signal is generated by monitoring the time after \overline{NMI} signal is detected)
- Regulated voltage, \overline{NMI} detecting voltage, \overline{STBY} detecting voltage are adjustable.
- At low voltage and re-start, the delay time of \overline{RES} signal is adjustable
- Watchdog timer filtering uses the minimum clock input pulse width and maximum cycle detection method

Ordering Information

Type No.	Package
HA16103FPJ	FP-20DA
HA16103FPK	FP-20DA

Pin Arrangement

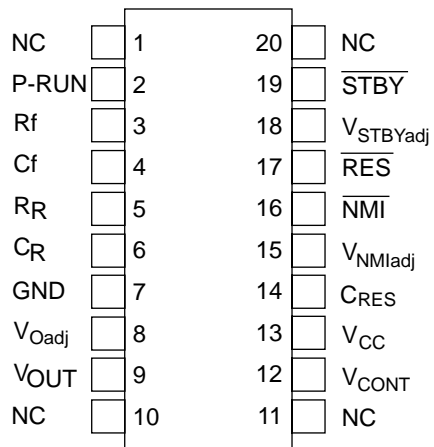

(Top view)

Pin Functions

No.	Pin Name	Description
1	NC	NC pin
2	P-RUN	P-RUN signal input pin for watchdog timer
3	R _f	Connect resistor R _f . Frequency bandwidth of the filter circuit depends on R _f
4	C _f	Connect resistor C _f . Frequency bandwidth of the filter circuit depends on C _f
5	R _R	Connect resistor R _R . Reset-signal power-on time depends on R _R
6	C _R	Connect resistor C _R . Reset-signal power-on time depends on C _R
7	GND	Ground
8	Voadj	5-V reference voltage fine-tuning pin. Connect a resistor between this pin and GND. The value of output voltage is given by $V_{OUT} = \{1 + 5.34/(R1 // 2.0)\} \times Voadj$ Unit for R1: kΩ
9	V _{OUT}	Connect the collector of an external PNP-type transistor. The pin supplies 5-V regulated voltage for internal circuit
10	NC	NC pin
11	NC	NC pin
12	V _{CONT}	The external PNP-type transistor's base control pin
13	V _{CC}	Supply voltage pin. Operating supply voltage range is 6.0 to 40 V.
14	C _{RES}	If the voltage of V _{OUT} pin declines to less than Detection voltage(1) (because of an instant power cut or other cause), \overline{NMI} signals are generated. If $t_{RES} \approx 0.5 \cdot R_f \cdot C_{RES}$ (sec) has passed since then, \overline{RES} signals are generated. If the voltage of V _{OUT} pin inclines to more than Detection voltage(1) (in case of re-start from LVI state), \overline{NMI} signals are stop. $t_r \approx 0.5 \cdot R_f \cdot C_{RES}$ (sec) has passed since then, \overline{RES} signals are stop. Connect capacitor C _{RES} between this pin and GND to adjust the \overline{RES} signals delay time(t_{RES} , t_r). If delay time is unnecessary, make this pin open ($t_{RES} = 2 \mu s$ typ. $t_r = 10 \mu s$ typ. at open)
15	V _{NMIadj}	\overline{NMI} detection voltage fine-tuning pin. Connect a resistor between this pin and V _{OUT} pin or GND. The value of output voltage is given by $V_{NMI} = \{1 + (R2 // 25.5)/(R3 // 10.6)\} \times V_{NMIadj}$ Unit for R2, R3: kΩ
16	\overline{NMI}	\overline{NMI} signal output pin. Connect to pin \overline{NMI} of the microcomputer
17	\overline{RES}	\overline{RES} signal output pin. Connect to pin \overline{RES} of the microcomputer
18	V _{STBYadj}	\overline{STBY} detection voltage tuning pin. Connect a resistor between this pin and V _{OUT} or GND. The value of output voltage is given by $V_{STBY} = 1.89 \times \{1 + 21/(7.9 + 8.85 // R4)\} \times V_{STBYadj}$ Unit for R4: kΩ
19	\overline{STBY}	\overline{STBY} signal output pin. Connect to pin \overline{STBY} of the microcomputer
20	NC	NC pin

Block Diagram

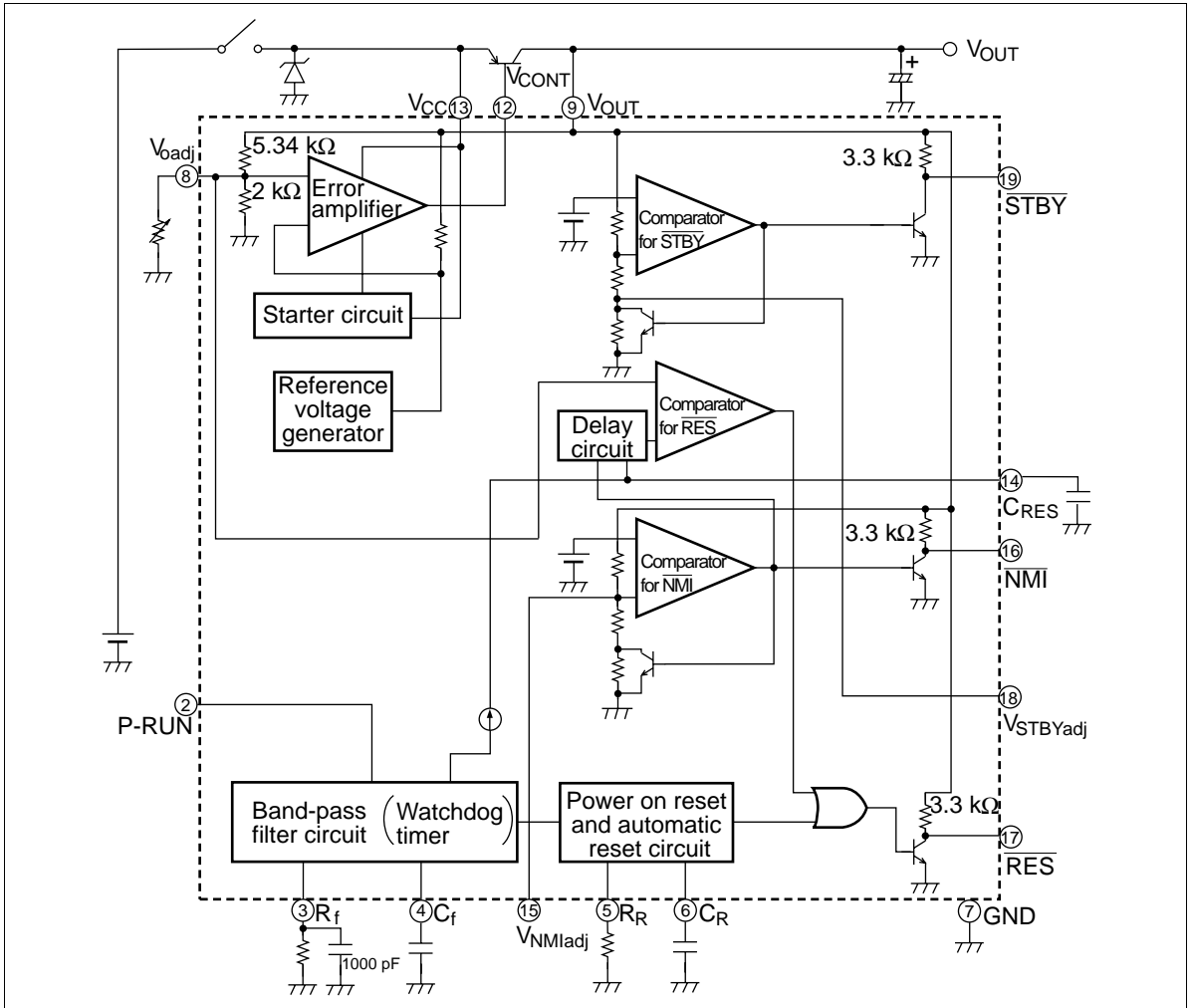

Functional Description

Stabilized Power Supply Function

The stabilized power supply includes the following features:

- Wide range of operating input voltage from 6 V to 40 V to provide stabilized voltages
- Availability of any output current, by simply replacing the external transistor
- Fine adjustment of output voltage

Figure 1 shows the fine adjustment circuit of the output circuit. Select the resistor R1 as shown in equation 1.

Add a resistor between GND and Voadj to increase the output voltage.

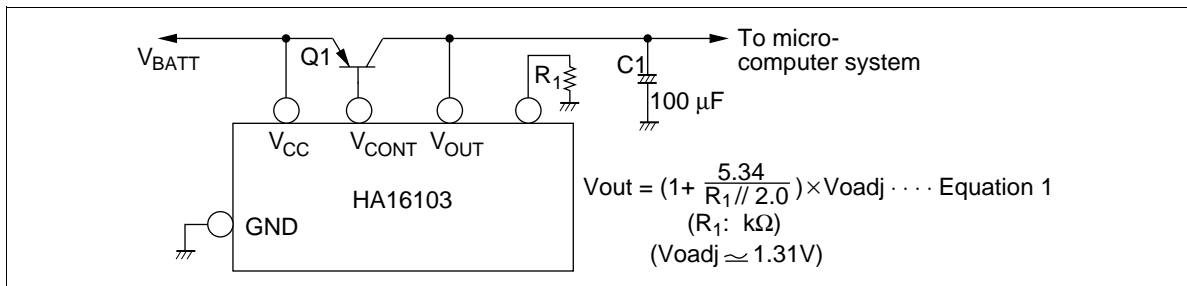

Figure 1 Fine Adjustment Circuit of Output Voltage

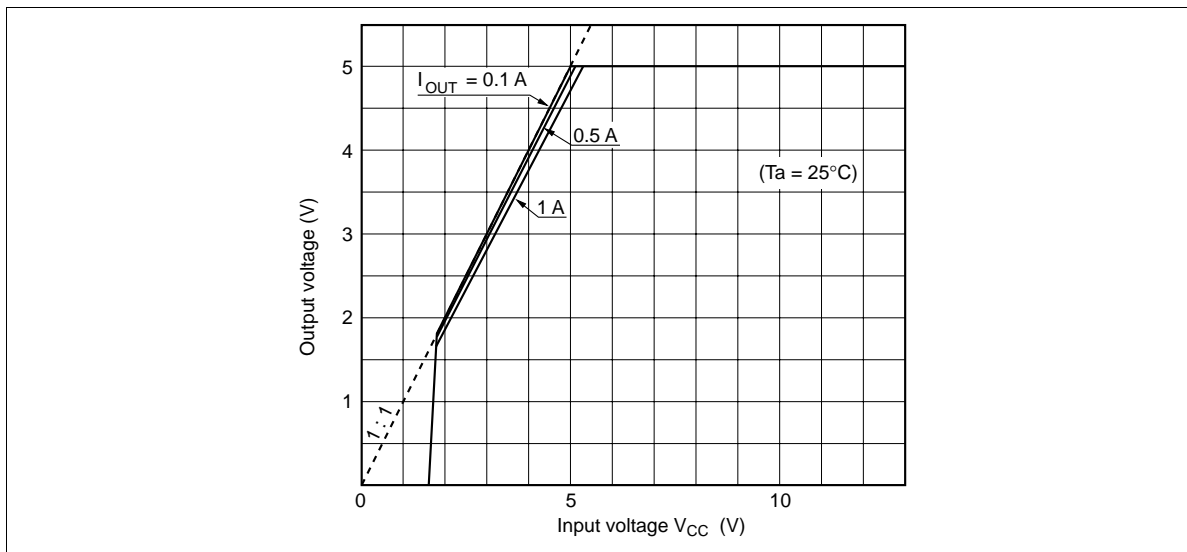
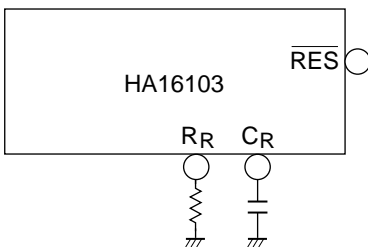

Figure 2 Output Voltage Characteristic

Power-On Reset Function

The system contains the power-on reset function required when a microcomputer is turned on.

The reset period may be set with external components R_R and C_R . Equation 2 specifies how to determine the reset period (t_{on}) and figure 3 shows the characteristic of the circuit.



$$t_{on} = 0.46 \times C_R \times R_R \times V_{out}(s) \dots \text{Equation 2}$$

R_R : Ω

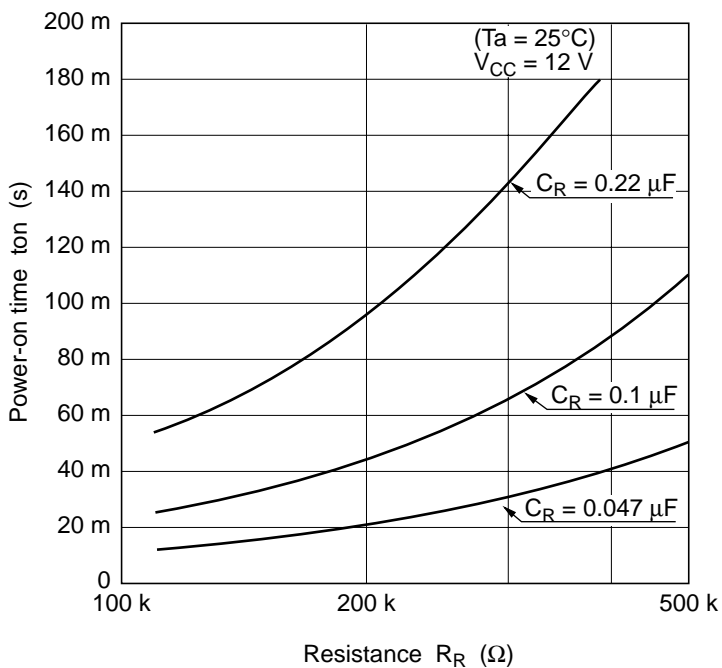
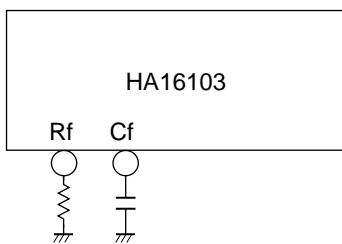

Figure 3 Characteristic of Power-On Reset Circuit

Watchdog Timer Function

The system contains a bandpass filter for pulse width detection, which outputs a reset pulse when input pulses are not at the preselected frequency (at either a higher or lower frequency).

The RC characteristic of the bandpass filter may be set with external components Rf and Cf. Equation 3 specifies how to determine the minimum pulse width (tmin) for runaway detection of the bandpass filter, and figure 4 shows the characteristic of the filter.



$$t_{min} = C_f \times R_f \times 0.11 \text{ (s)} \dots \text{Equation 3}$$

Rf : Ω

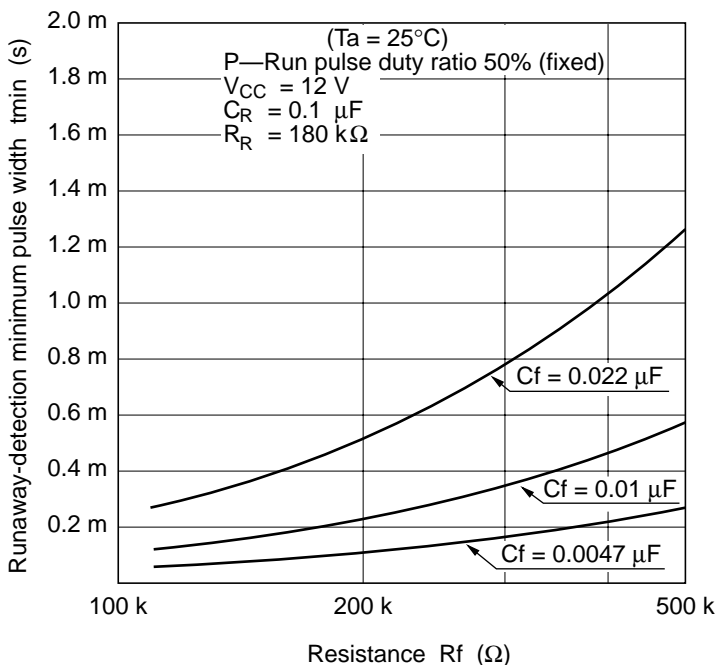

Figure 4 Characteristic of Power-On Reset Circuit

Low Voltage Monitoring Function

The system contains a circuit to send a control signal to the microcomputer when the output voltage drops. The circuit includes the following features.

- Two-point monitoring of output voltage (V_{NMI} and V_{STBY})
- Availability of fine adjustment of V_{th1} (V_{NMI}) and V_{th2} (V_{STBY})
- Output of control signal in standby mode of microcomputer

Figure 5 shows the timing chart of control signals when the output voltage drops.

If the output voltage drops below V_{th1} (4.60 V), the \overline{NMI} signal rises to request the microcomputer to issue the \overline{NMI} interrupt signal. The \overline{RES} signal falls t_{RES} seconds after the \overline{NMI} signal rises. If the output voltage drops further to below V_{th2} (3.2 V), the \overline{STBY} signal rises to enable the micro-computer to enter standby mode.

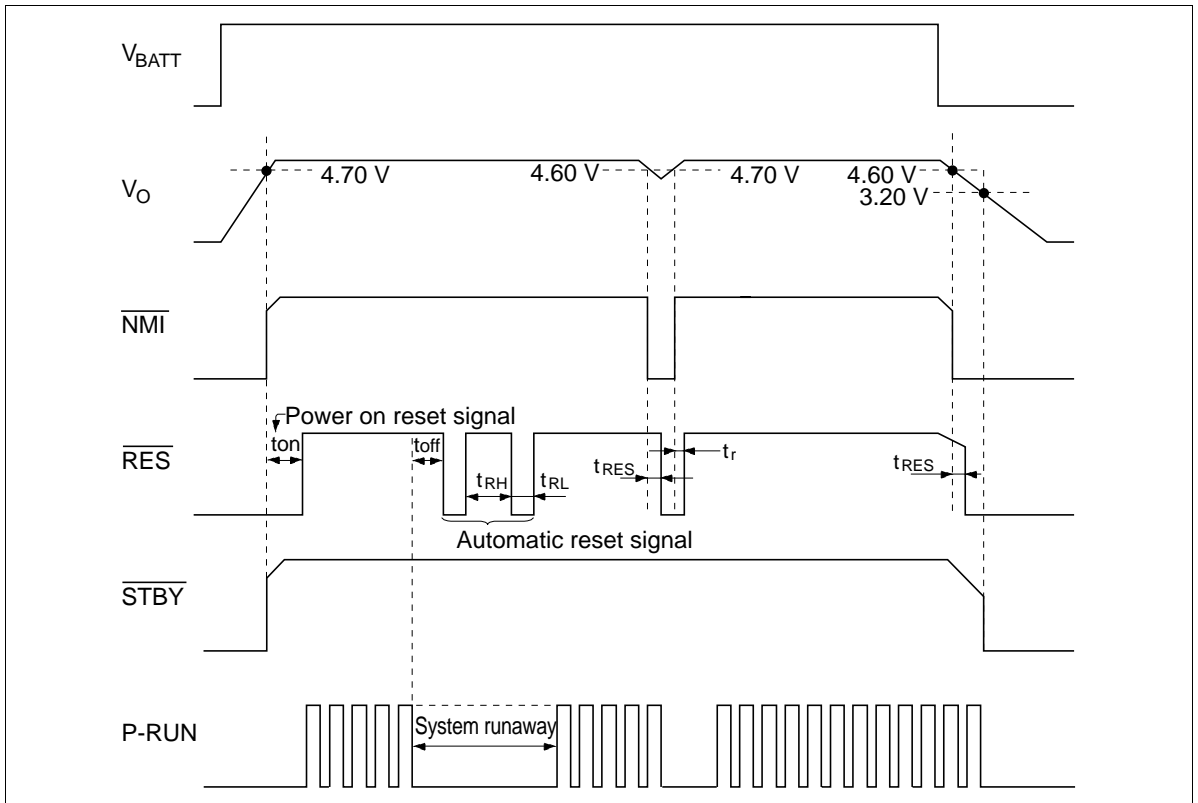

Figure 5 Timing Chart for Low Voltage Monitoring

Absolute Maximum Ratings (Ta = 25°C)

Item	Symbol	Ratings		Units
		HA16103FPJ	HA16103FPK	
V _{CC} supply voltage	V _{CC}	40	40	V
Control pin voltage	V _{CONT}	40	40	V
Control pin current	I _{CONT}	20	20	mA
V _{OUT} pin voltage	V _{OUT}	12	12	V
Power dissipation	P _T	400* ¹	400* ²	mW
Operating ambient temperature range	Topr	-40 to +85	-40 to +125	°C
Storage temperature range	Tstg	-50 to +125	-50 to +150	°C

Notes: 1. Value under Ta ≤ 77°C. If Ta is greater, 8.3 mW/°C derating occurs.

2. Allowable temperature of IC junction part, Tj(max), is as shown below.

$$T_j(\text{max}) = \theta_{j-a} \cdot P_c(\text{max}) + T_a$$

(θ_{j-a} is thermal resistance value during mounting, and P_c(max) is the maximum value of IC power dissipation.)

Therefore, to keep T_j(max) ≤ 125°C, wiring density and board material must be selected according to the board thermal conductivity ratio shown below.

Be careful that the value of P_c(max) does not exceed that P_T.

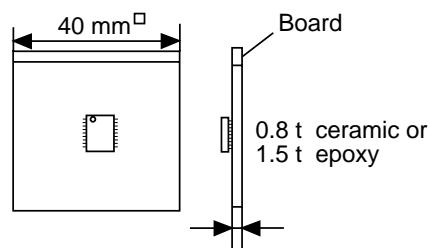
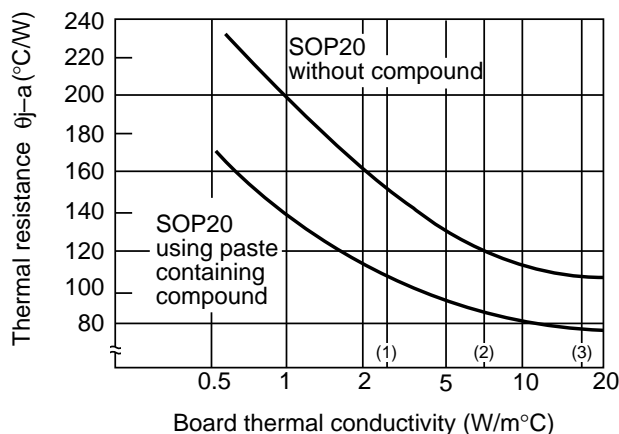

- (1) Glass epoxy board with 10% wiring density
- (2) Glass epoxy board with 30% wiring density
- (3) Ceramic board with 96% alumina coefficient

HA16103 FPJ/FPK

Electrical Characteristics (Ta = 25°C, V_{CC} = 12 V, V_{OUT} = 5 V)

HA16103FPJ/FPK

Item		Symbol	Min	Typ	Max	Unit	Test Condition
Regulator	Supply current	I _{CCL}	—	8	12	mA	V _{CC} = 12 V
	Output voltage	V _{O1}	4.80	5.00	5.20	V	V _{CC} = 6 to 17.5 V I _{OUT} = 0.5 A, R ₁ = 30 kΩ
		V _{O2}	4.70	5.00	5.30	V	V _{CC} = 6 to 17.5 V I _{OUT} = 1 A, R ₁ = 30 kΩ
	Line regulation	V _{oline}	-50	—	50	mV	V _{CC} = 6 to 17.5 V I _{OUT} = 1 A, R ₁ = 30 kΩ
	Load regulation	V _{oload}	-100	—	100	mV	I _{OUT} = 10 mA to 0.5 A, R ₁ = 30 kΩ
	Ripple rejection	R _{REJ}	45	75	—	dB	V _i = 0.5 V _{rms} , f _i = 1 kHz, R ₁ = 30 kΩ
	Output voltage Temperature coefficient	δV _O /δT	—	0.6	—	mV/°C	V _{CC} = 12 V, R ₁ = 30 kΩ
Clock input	"L"-input voltage	V _{IL}	—	—	0.8	V	
	"H"-input voltage	V _{IH}	2.0	—	—	V	
	"L"-input current	I _{IL}	-120	-60	—	μA	V _{IL} = 0 V
	"H"-input current	I _{IH}	—	0.3	0.5	mA	V _{IH} = 5 V

Electrical Characteristics ($T_a = 25^\circ\text{C}$, $V_{CC} = 12\text{ V}$, $V_{OUT} = 5\text{ V}$) (cont)

Item		Symbol	Min	Typ	Max	Unit	Test Condition
NMI output	NMI pin "L"-level voltage	V_{OL1}	—	—	0.4	V	$I_{OL1} = 2\text{ mA}$
	NMI pin "H"-level voltage	V_{OH1}	—	V_{O1} (V_{O2})	—	V	
	NMI function start V_{OUT} voltage	V_{NMI}	—	0.7	1.4	V	
STBY output	STBY pin "L"-level voltage	V_{OL2}	—	—	0.4	V	$I_{OL2} = 2\text{ mA}$
	STBY pin "H"-level voltage	V_{OH2}	—	V_{O1} (V_{O2})	—	V	
	STBY function start V_{OUT} voltage	V_{STBY}	—	0.7	1.4	V	
RES output	RES pin "L"-level voltage	V_{OL3}	—	—	0.4	V	$I_{OL3} = 2\text{ mA}$
	RES pin "H"-level voltage	V_{OH3}	—	V_{O1} (V_{O2})	—	V	
	RES function start V_{OUT} voltage	V_{RES}	—	0.7	1.4	V	
	Power on time	t_{ON}	25	40	60	ms	$R_f = 180\text{ k}\Omega$, $R_R = 180\text{ k}\Omega$ $C_f = 0.01\text{ }\mu\text{F}$, $C_R = 0.1\text{ }\mu\text{F}$
	Clock off reset time	t_{OFF}	80	130	190	ms	
	Reset pulse "L"-level time	t_{RL}	15	20	30	ms	$R_f = 180\text{ k}\Omega$, $R_R = 180\text{ k}\Omega$ $C_f = 0.01\text{ }\mu\text{F}$, $C_R = 0.1\text{ }\mu\text{F}$
Reset pulse "H"-level time	t_{RH}	37	60	90	ms	$R_f = 180\text{ k}\Omega$, $R_R = 180\text{ k}\Omega$ $C_f = 0.01\text{ }\mu\text{F}$, $C_R = 0.1\text{ }\mu\text{F}$	
Low Voltage protecton	Detection voltage(1)	V_{H1}	4.40	4.60	4.80	V	
	Detection voltage(1) Hysteresis width	V_{HYS1}	50	100	150	mV	
	Detection voltage(2)	V_{H2}	2.9	3.2	3.5	V	
	Detection voltage(2) Hysteresis width	V_{HYS2}	1.35	1.5	1.65	V	
	Reset pulse	inhibit	t_{RES}	—	200	—	μs
Delay time	restart	t_r	—	200	—	μs	$C_{RES} = 2200\text{ pF}$

HA16103 FPJ/FPK

Electrical Characteristics ($T_a = -40$ to 125°C , $V_{CC} = 12$ V, $V_{OUT} = 5$ V, $R1 = 30$ k Ω)
(cont)

HA16103FPK

Item		Symbol	Min	Typ	Max	Unit	Test Condition
	Supply current	I_{CC1}	—	7	13	mA	
Regulator	Output voltage	V_{out1}	4.80	5.00	5.20	V	$V_{CC} = 6$ to 17.5 V $I_{OUT} = 0.5$ A
	Line regulation	V_{oline}	-50	—	50	mV	$V_{CC} = 6$ to 17.5 V $I_{OUT} = 0.5$ A
	Load regulation	V_{oload}	-100	—	100	mV	$I_{OUT} = 10$ mA to 0.5 A
Clock input	"L"-input voltage	V_{IL}	—	—	0.4	V	
	"H"-input voltage	V_{IH}	2.4	—	—	V	
	"L"-input current	I_{IL}	-120	-60	—	μA	$V_{IL} = 0$ V
	"H"-input current	I_{IH}	—	0.3	0.6	mA	$V_{IH} = 5$ V
NMI output	NMI pin "L"-level voltage	V_{OLN}	—	—	0.5	V	$I_{OL1} = 2$ mA
	NMI pin "H"-level voltage	V_{OHN}	—	V_{OUT1}	—	V	
STBY output	STBY pin "L"-level voltage	V_{OLS}	—	—	0.5	V	$I_{OL2} = 2$ mA
	STBY pin "H"-level voltage	V_{OHS}	—	V_{OUT1}	—	V	
RES output	RES pin "L"-level voltage	V_{OLR}	—	—	0.5	V	$I_{OL3} = 2$ mA
	RES pin "H"-level voltage	V_{OHR}	—	V_{OUT1}	—	V	
	Power on time	t_{ON}	25	40	60	ms	$R_f = 180$ k Ω , $R_R = 180$ k Ω
	Clock off reset time	t_{OFF}	70	130	200	ms	$C_f = 0.01$ μF , $C_R = 0.1$ μF
	Reset pulse "L"-level time	t_{RL}	15	20	30	ms	$R_f = 180$ k Ω , $R_R = 180$ k Ω $C_f = 0.01$ μF , $C_R = 0.1$ μF
	Reset pulse "H"-level time	t_{RH}	30	60	100	ms	$R_f = 180$ k Ω , $R_R = 180$ k Ω $C_f = 0.01$ μF , $C_R = 0.1$ μF
Low Voltage protecton	Detection voltage(1)	V_{NMI}	4.35	4.60	4.85	V	
	Detection voltage(2)	V_{STBY}	2.80	3.20	3.60	V	

Test Circuit

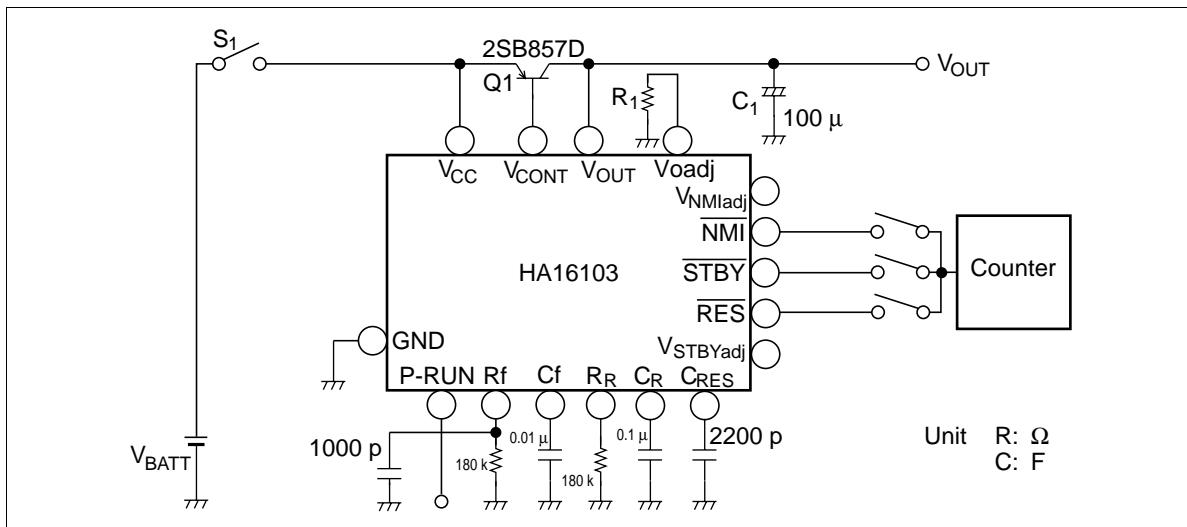

Sample Connection Circuit

Sample Connection Circuit between HA16103 and H8/532

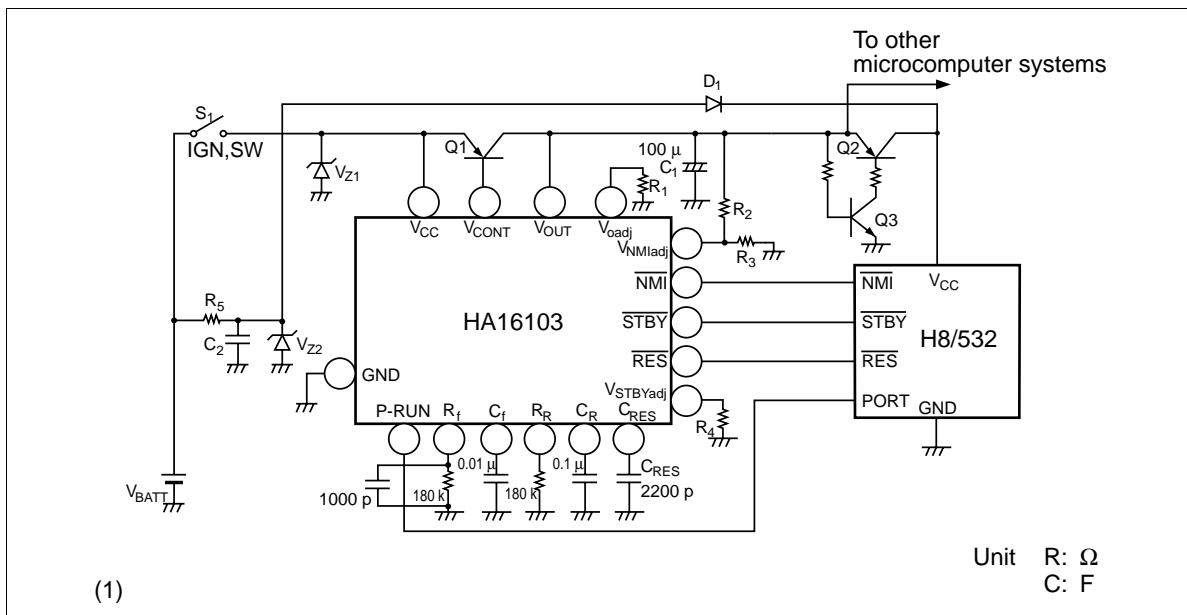

(1)

HA16103 FPJ/FPK

Sample Connection Circuit between HA16103 and H8/532 (2)

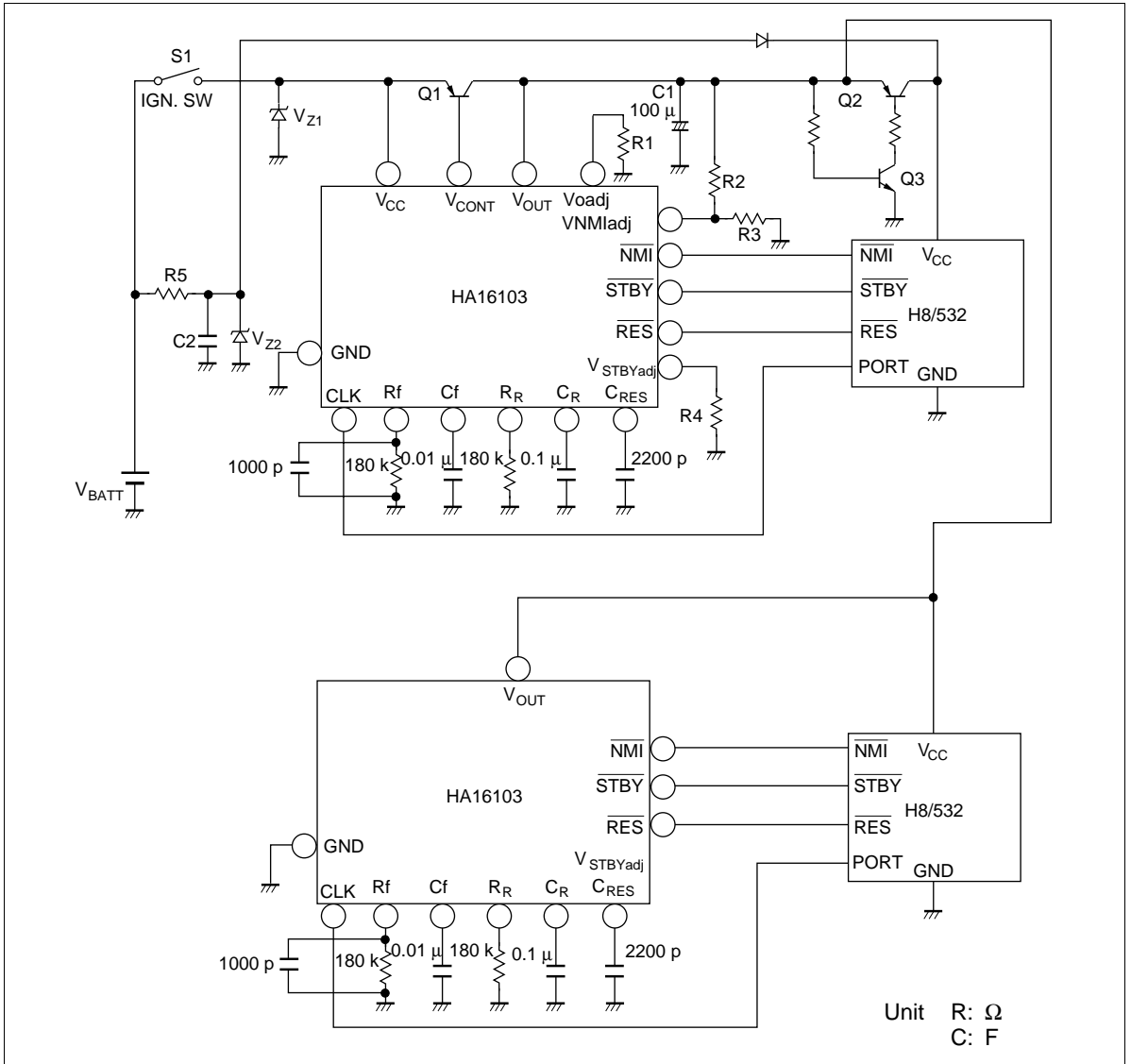

Precautions

If the IC's ground potential varies suddenly by several volts due to wiring impedance (see figure 6), a false $\overline{\text{RES}}$ pulse may be output. The reason for this is that potentials in the $\overline{\text{RES}}$ pulse generating circuit change together with the $V_{\text{OUT}}\text{-GND}$ potential. The reference potential of the comparator in figure 7 and the potential of the external capacitor have different impedances as seen from the comparator, causing a momentary inversion. The solution is to stabilize the ground potential. Two ways of stabilizing the IC's ground line are:

- Separate the IC's ground line from highcurrent ground lines.
- Increase the capacitance (C_0) used to smooth the V_{OUT} output.

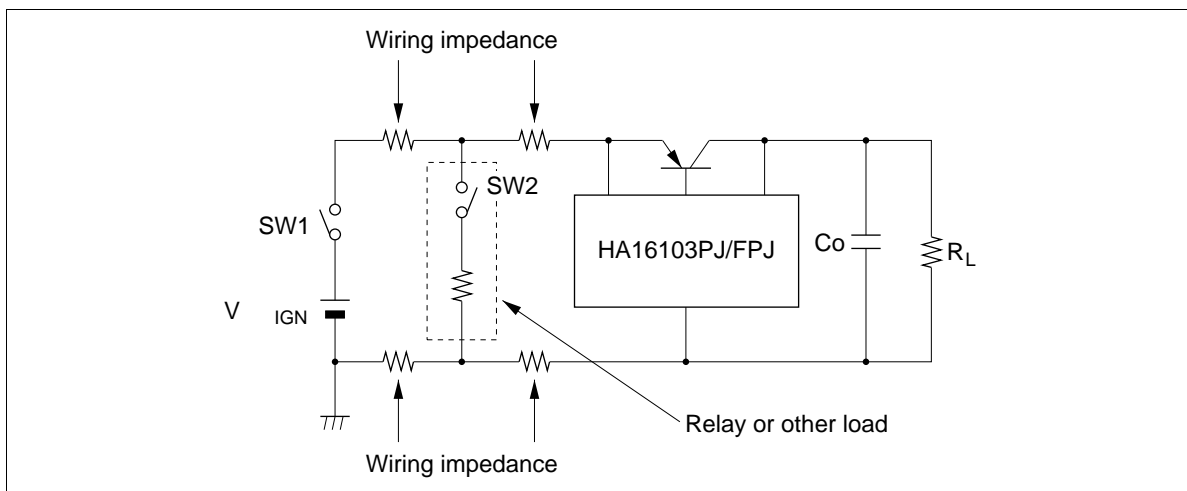

Figure 6 Typical Circuit

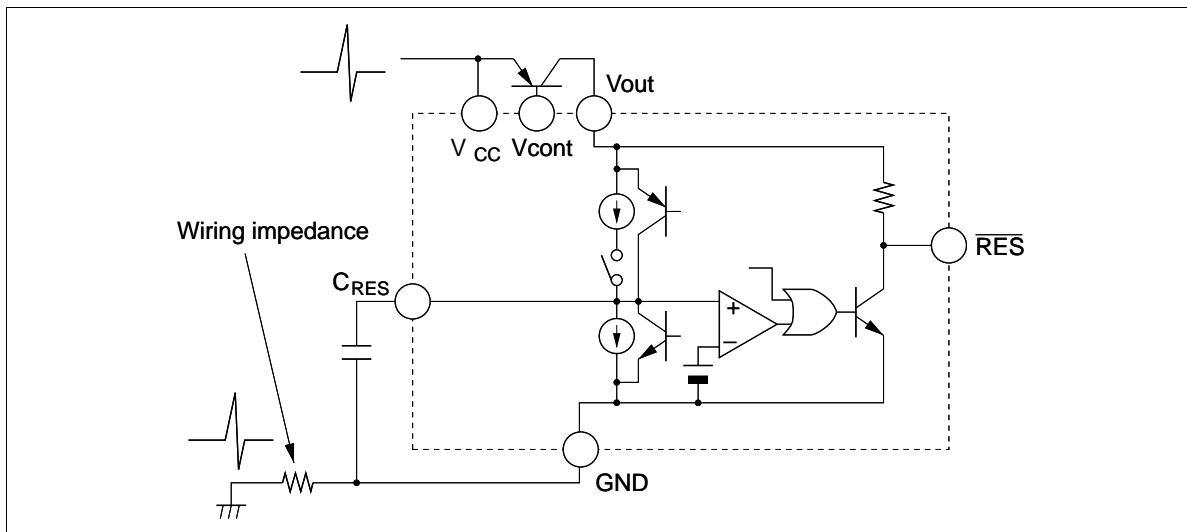
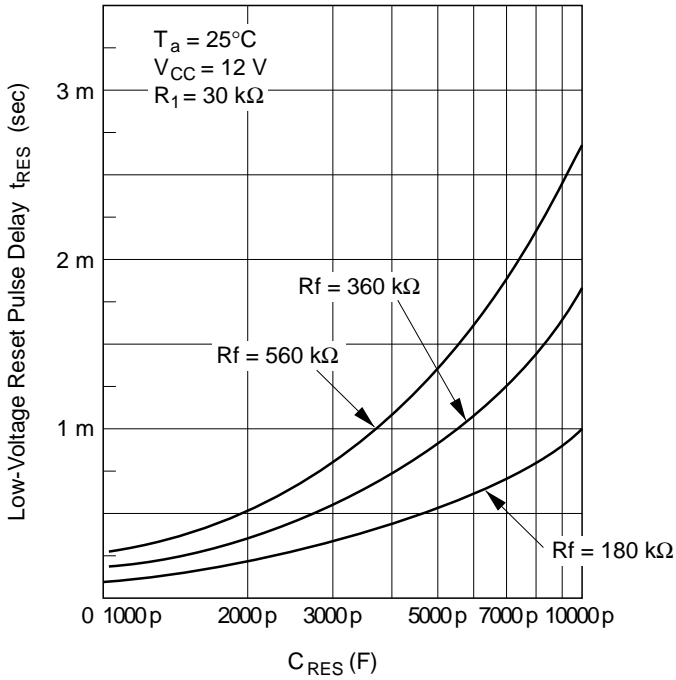

Figure 7 $\overline{\text{RES}}$ Comparator

• Low-voltage inhibit section

Low-Voltage Reset Pulse Delay vs. C_{RES}



Permissible P-RUN Pulse Duty Cycle vs. P-RUN Pulse Frequency

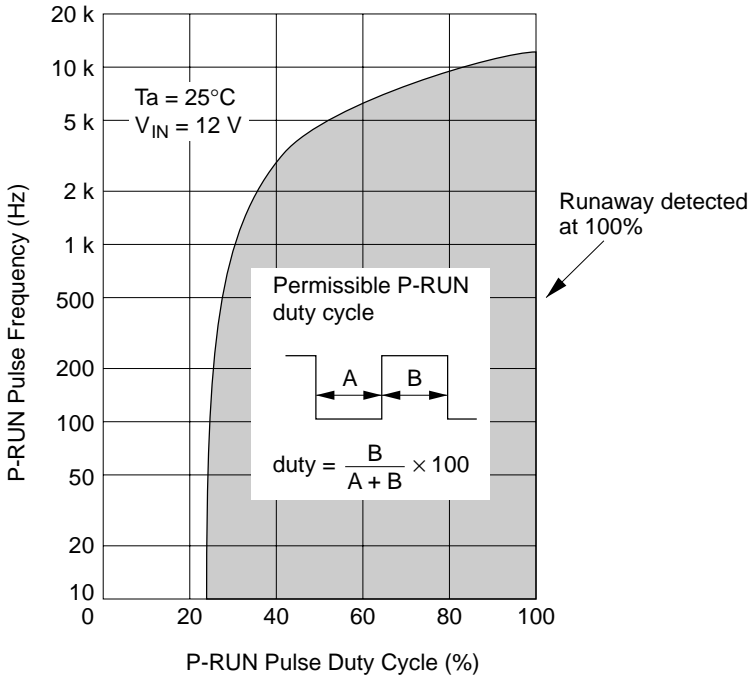

- Low-voltage inhibit section
Low-Voltage Reset Pulse Recovery Delay vs. C_{RES}

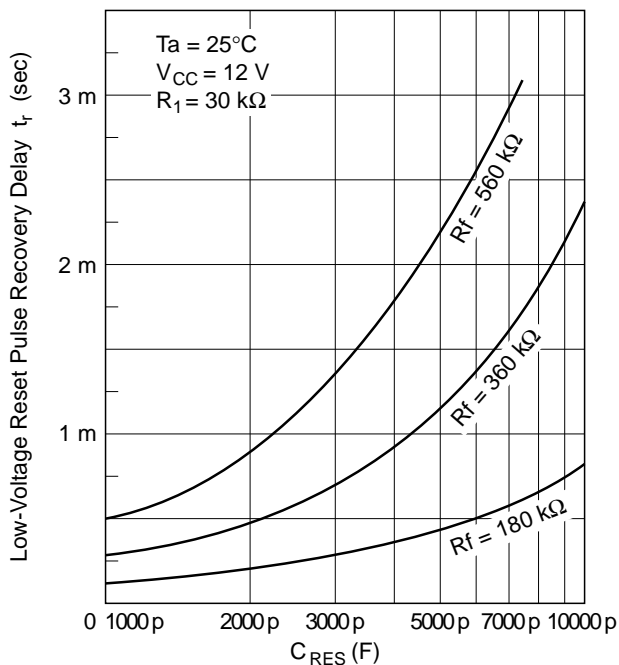

- Power-on and auto-reset section
Reset Low Time vs. Resistance R_R

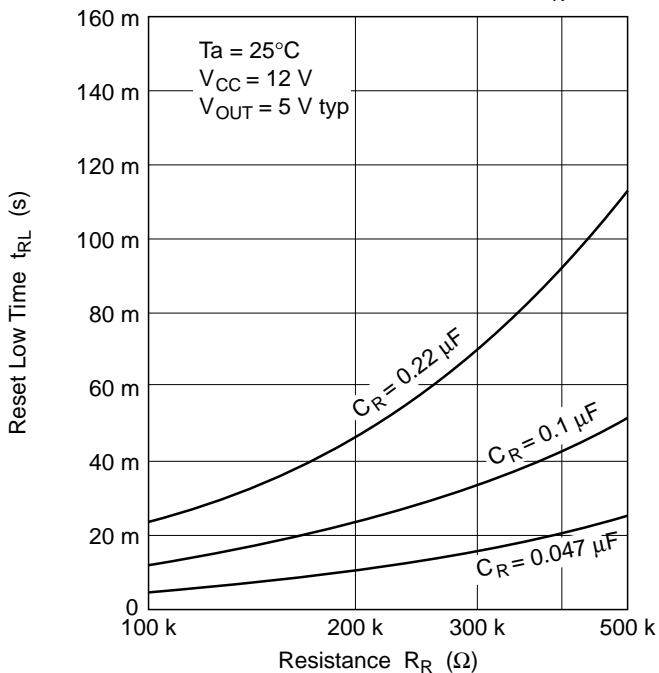

• Power-on and auto-reset section

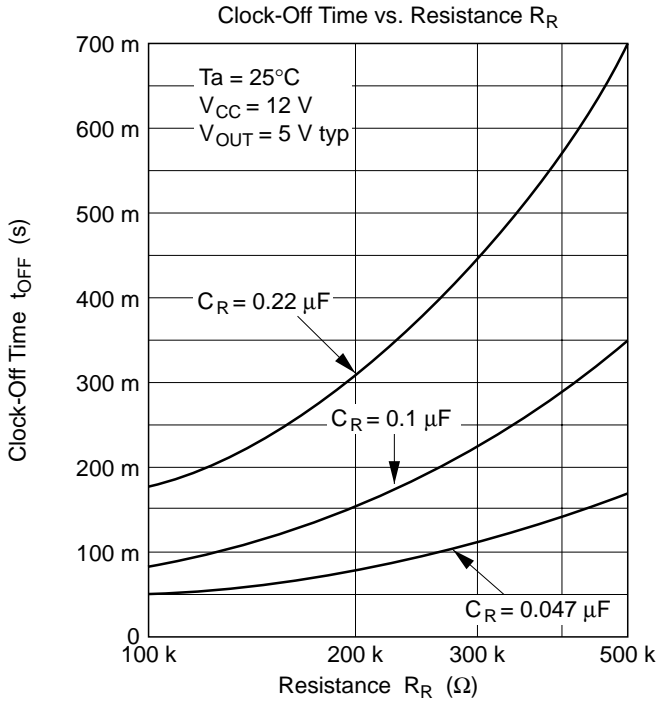

• Vref section

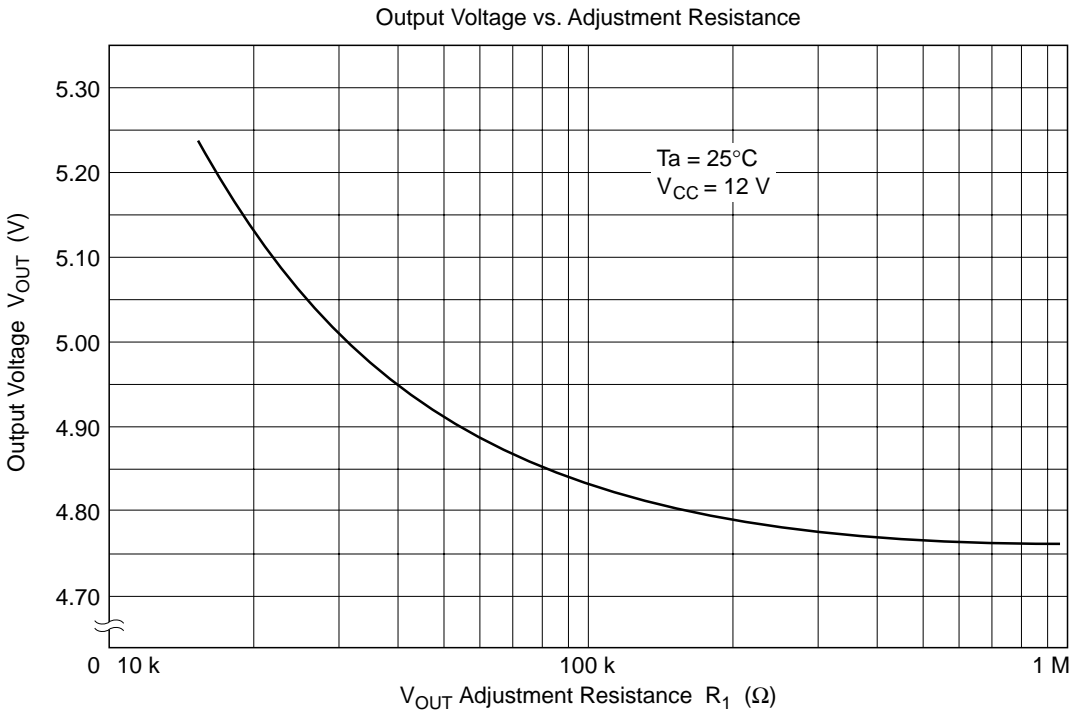

• Power-on and auto-reset section

Reset High Time vs. Resistance R_R

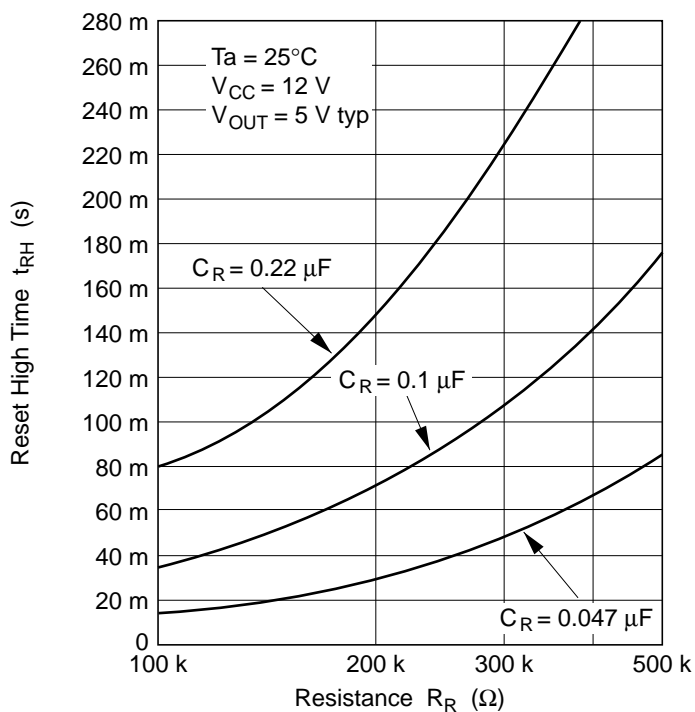

Package Dimensions

Unit: mm

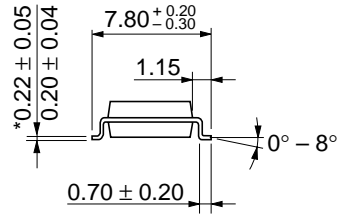
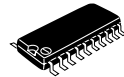
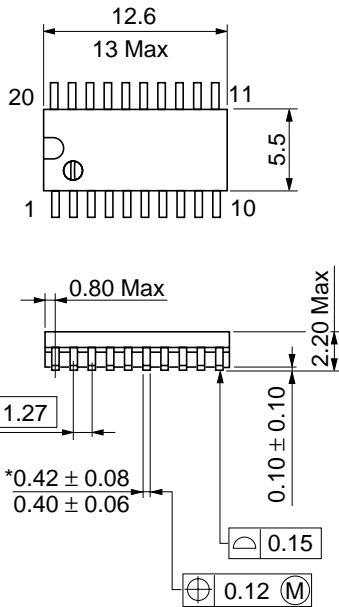

*Dimension including the plating thickness
Base material dimension

Hitachi Code	FP-20DA
JEDEC	—
EIAJ	Conforms
Mass (reference value)	0.31 g

Cautions

1. Hitachi neither warrants nor grants licenses of any rights of Hitachi's or any third party's patent, copyright, trademark, or other intellectual property rights for information contained in this document. Hitachi bears no responsibility for problems that may arise with third party's rights, including intellectual property rights, in connection with use of the information contained in this document.
2. Products and product specifications may be subject to change without notice. Confirm that you have received the latest product standards or specifications before final design, purchase or use.
3. Hitachi makes every attempt to ensure that its products are of high quality and reliability. However, contact Hitachi's sales office before using the product in an application that demands especially high quality and reliability or where its failure or malfunction may directly threaten human life or cause risk of bodily injury, such as aerospace, aeronautics, nuclear power, combustion control, transportation, traffic, safety equipment or medical equipment for life support.
4. Design your application so that the product is used within the ranges guaranteed by Hitachi particularly for maximum rating, operating supply voltage range, heat radiation characteristics, installation conditions and other characteristics. Hitachi bears no responsibility for failure or damage when used beyond the guaranteed ranges. Even within the guaranteed ranges, consider normally foreseeable failure rates or failure modes in semiconductor devices and employ systemic measures such as fail-safes, so that the equipment incorporating Hitachi product does not cause bodily injury, fire or other consequential damage due to operation of the Hitachi product.
5. This product is not designed to be radiation resistant.
6. No one is permitted to reproduce or duplicate, in any form, the whole or part of this document without written approval from Hitachi.
7. Contact Hitachi's sales office for any questions regarding this document or Hitachi semiconductor products.

HITACHI

Hitachi, Ltd.

Semiconductor & Integrated Circuits.

Nippon Bldg., 2-6-2, Ohte-machi, Chiyoda-ku, Tokyo 100-0004, Japan
Tel: Tokyo (03) 3270-2111 Fax: (03) 3270-5109

URL NorthAmerica : <http://semiconductor.hitachi.com/>
 Europe : <http://www.hitachi-eu.com/hel/ecg>
 Asia : <http://sicapac.hitachi-asia.com>
 Japan : <http://www.hitachi.co.jp/Sicd/indx.htm>

For further information write to:

Hitachi Semiconductor
(America) Inc.
179 East Tasman Drive,
San Jose, CA 95134
Tel: <1> (408) 433-1990
Fax: <1> (408) 433-0223

Hitachi Europe GmbH
Electronic Components Group
Dornacher Straße 3
D-85622 Feldkirchen, Munich
Germany
Tel: <49> (89) 9 9180-0
Fax: <49> (89) 9 29 30 00

Hitachi Europe Ltd.
Electronic Components Group.
Whitebrook Park
Lower Cookham Road
Maidenhead
Berkshire SL6 8YA, United Kingdom
Tel: <44> (1628) 585000
Fax: <44> (1628) 585160

Hitachi Asia Ltd.
Hitachi Tower
16 Collyer Quay #20-00,
Singapore 049318
Tel : <65>-538-6533/538-8577
Fax : <65>-538-6933/538-3877
URL : <http://www.hitachi.com.sg>

Hitachi Asia Ltd.
(Taipei Branch Office)
4/F, No. 167, Tun Hwa North Road,
Hung-Kuo Building,
Taipei (105), Taiwan
Tel : <886>-(2)-2718-3666
Fax : <886>-(2)-2718-8180
Telex : 23222 HAS-TP
URL : <http://www.hitachi.com.tw>

Hitachi Asia (Hong Kong) Ltd.
Group III (Electronic Components)
7/F., North Tower,
World Finance Centre,
Harbour City, Canton Road
Tsim Sha Tsui, Kowloon,
Hong Kong
Tel : <852>-(2)-735-9218
Fax : <852>-(2)-730-0281
URL : <http://www.hitachi.com.hk>

Copyright © Hitachi, Ltd., 2000. All rights reserved. Printed in Japan.
Colophon 2.0