



NEC's
4-PIN ULTRA SMALL FLAT-LEAD
SUPER LOW OUTPUT CAPACITANCE
1-ch OPTICAL COUPLED MOS FET

PS7801C-1A

FEATURES

- **ULTRA SMALL FLAT-LEAD PACKAGE:**
4.2 (L) × 2.5 (W) × 1.85 (H) mm
- **SUPER LOW OUTPUT CAPACITANCE:**
 $C_{out} = 0.5 \text{ pF TYP.}$
- **LOW C × R:**
 $C \times R = 6.5 \text{ pF} \cdot \Omega$
- **1 CHANNEL TYPE:**
1 a output
- **DESIGN FOR AC/DC SWITCHING LINE CHANGER**
- **LOW OFFSET VOLTAGE**
- **ORDERING NUMBER OF TAPING PRODUCT:**
PS7801C-1A-F3, F4: 3 500 pcs/reel

DESCRIPTION

NEC's PS7801C-1A is a low output capacitance solid state relay containing a GaAs LED on the light emitting side (input side) and MOS FETs on the output side.

An ultra small flat-lead package has been provided which realizes a reduction in mounting area of about 50% compared with the PS72xx series.

It is suitable for high-frequency signal control, due to its low C × R, super low output capacitance, and low off-state leakage current.

APPLICATION

- **Measurement Equipment**

PACKAGE DIMENSIONS (UNIT: mm)

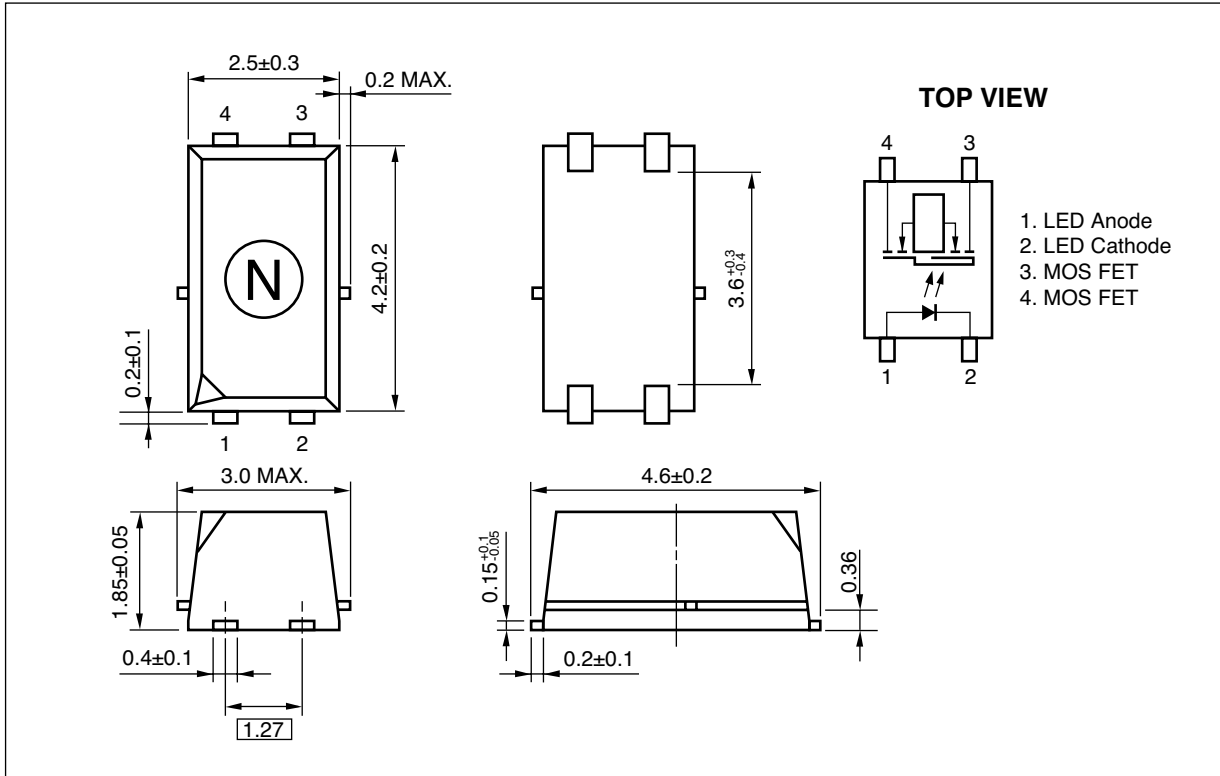

MARKING EXAMPLE

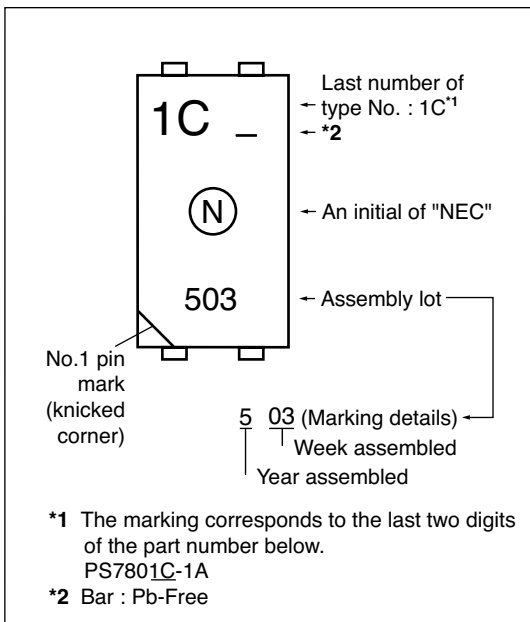

ORDERING INFORMATION

| PART NUMBER | ORDER NUMBER | SOLDER PLATING SPECIFICATION | PACKING STYLE |
|---------------|-----------------|------------------------------|------------------------------|
| PS7801C-1A-F3 | PS7801C-1A-F3-A | Pb-Free | Embossed Tape 3 500 pcs/reel |
| PS7801C-1A-F4 | PS7801C-1A-F4-A | | |

ABSOLUTE MAXIMUM RATINGS ($T_A = 25^\circ\text{C}$, unless otherwise Specified)

| | PARAMETER | SYMBOL | RATINGS | UNIT |
|---------------------------------|--|-----------|-------------|------------------|
| Diode | Forward Current (DC) | I_F | 50 | mA |
| | Reverse Voltage | V_R | 5.0 | V |
| | Power Dissipation | P_D | 50 | mW |
| | Peak Forward Current ^{*1} | I_{FP} | 1 | A |
| MOS FET | Break Down Voltage | V_L | 30 | V |
| | Continuous Load Current | I_L | 80 | mA |
| | Pulse Load Current ^{*2} (AC/DC Connection) | I_{LP} | 160 | mA |
| | Power Dissipation | P_D | 250 | mW |
| Isolation Voltage ^{*3} | | BV | 500 | Vr.m.s. |
| Total Power Dissipation | | P_T | 300 | mW |
| Operating Ambient Temperature | | T_A | -40 to +85 | $^\circ\text{C}$ |
| Storage Temperature | | T_{stg} | -40 to +100 | $^\circ\text{C}$ |

*1 $PW = 100 \mu\text{s}$, Duty Cycle = 1%

*2 $PW = 100 \text{ms}$, 1 shot

*3 AC voltage for 1 minute at $T_A = 25^\circ\text{C}$, RH = 60% between input and output.

Pins 1-2 shorted together, 3-4 shorted together.

RECOMMENDED OPERATING CONDITIONS ($T_A = 25^\circ\text{C}$)

| PARAMETER | SYMBOL | MIN. | TYP. | MAX. | UNIT |
|-----------------------|--------|------|------|------|------|
| LED Operating Current | I_F | 2 | 5 | 20 | mA |
| LED Off Voltage | V_F | 0 | | 0.5 | V |

ELECTRICAL CHARACTERISTICS (TA = 25 85°C)

| PARAMETER | | SYMBOL | CONDITIONS | MIN. | TYP. | MAX. | UNIT |
|-----------|---------------------------|------------|--|--------|------|------|---------------|
| Diode | Forward Voltage | V_F | $I_F = 5 \text{ mA}$ | | 1.1 | 1.4 | V |
| | Reverse Current | I_R | $V_R = 5 \text{ V}$ | | | 5.0 | μA |
| MOS FET | Off-state Leakage Current | I_{Loff} | $V_D = 30 \text{ V}$ | | 0.1 | 1.0 | nA |
| | Output Capacitance | C_{out} | $V_D = 0 \text{ V}, f = 1 \text{ MHz}$ | | 0.5 | 0.7 | pF |
| Coupled | LED On-state Current | I_{Fon} | $I_L = 80 \text{ mA}$ | | | 2.0 | mA |
| | On-state Resistance | R_{on} | $I_F = 5 \text{ mA}, I_L = 80 \text{ mA}$ | | 13 | 17 | Ω |
| | Turn-on Time*1,2 | t_{on} | $I_F = 5 \text{ mA}, V_O = 5 \text{ V}, R_L = 500 \Omega,$ | | 0.03 | 0.5 | ms |
| | Turn-off Time*1,2 | t_{off} | $PW \geq 10 \text{ ms}$ | | 0.1 | 0.5 | |
| | Isolation Resistance | R_{I-O} | $V_{I-O} = 0.5 \text{ kVDC}$ | 10^9 | | | Ω |
| | Isolation Capacitance | C_{I-O} | $V = 0 \text{ V}, f = 1 \text{ MHz}$ | | 0.3 | | pF |

***1 Test Circuit for Switching Time**

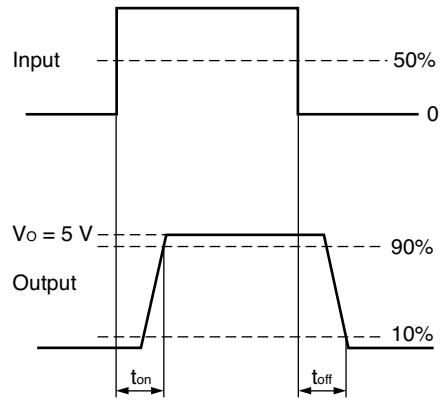
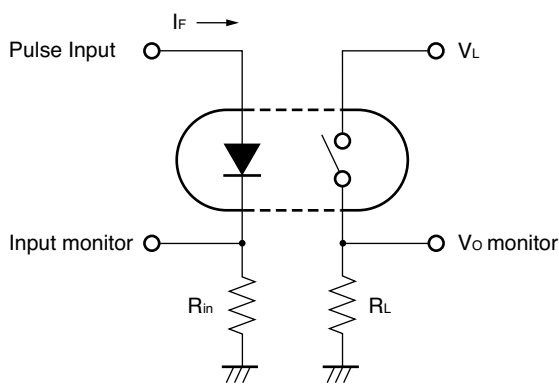

***2** The turn-on time and turn-off time are specified as input-pulse width $\geq 10 \text{ ms}$.

Be aware that when the device operates with an input-pulse width less than 10 ms, the turn-on time and turn-off time will increase.

NOTES ON HANDLING

Recommended soldering conditions

(1) Infrared reflow soldering

- Peak reflow temperature 260°C or below (package surface temperature)
- Time of peak reflow temperature 10 seconds or less
- Time of temperature higher than 220°C 60 seconds or less
- Time to preheat temperature from 120 to 180°C 120±30 s
- Number of reflows Three
- Flux Rosin flux containing small amount of chlorine (The flux with a maximum chlorine content of 0.2 Wt% is recommended.)

Recommended Temperature Profile of Infrared Reflow

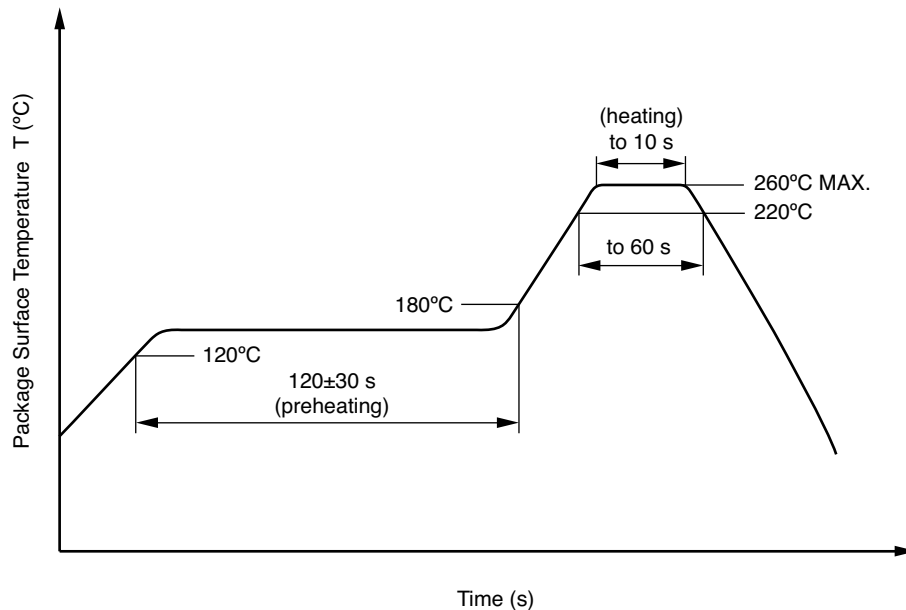

(2) Wave soldering

- Temperature 260°C or below (molten solder temperature)
- Time 10 seconds or less
- Preheating conditions 120°C or below (package surface temperature)
- Number of times One
- Flux Rosin flux containing small amount of chlorine (The flux with a maximum chlorine content of 0.2 Wt% is recommended.)

(3) Cautions

- Fluxes
Avoid removing the residual flux with freon-based and chlorine-based cleaning solvent.

Life Support Applications

These NEC products are not intended for use in life support devices, appliances, or systems where the malfunction of these products can reasonably be expected to result in personal injury. The customers of CEL using or selling these products for use in such applications do so at their own risk and agree to fully indemnify CEL for all damages resulting from such improper use or sale.

CEL California Eastern Laboratories, Your source for NEC RF, Microwave, Optoelectronic, and Fiber Optic Semiconductor Devices.
4590 Patrick Henry Drive • Santa Clara, CA 95054-1817 • (408) 988-3500 • FAX (408) 988-0279 • www.cel.com

DATA SUBJECT TO CHANGE WITHOUT NOTICE

04/11/2005