

Features

- SoundDesign™ Advanced Research
 - 128-band adaptive noise reduction
 - adaptive feedback cancellation
- 128-bit fingerprint security system and other security features to protect against device cloning and software piracy
- soft acoustic fade between memory changes
- FRONTWAVE® directional processing
- high fidelity audio CODEC
- 20-bit audio precision
- 95dB input dynamic range with HRX™ Headroom Extension
- 1, 2 or 4 channel WDRC compression
- 8-band graphic EQ
- 8 biquadratic filters
- drives zero-bias 2-terminal receivers
- 4 analog inputs
- 4 fully configurable memories with audible memory change indicator
- 2 memory select pads
- internal or external volume control
- AGCo with variable threshold, time constants, and optional adaptive release
- 16kHz or 8kHz bandwidth
- optimized programming speed
- thinSTAX™ packaging

thinSTAX PACKAGING

- Hybrid typical dimensions:
0.215 x 0.124 x 0.065in.
5.46 x 3.15 x 1.65mm

Description

Venture is Gennum's premiere DSP product designed on the Voyageur™ platform. Combining the power and capabilities of Voyageur together with SoundDesign Advanced Research, Venture delivers cutting-edge features and high performance.

Voyageur is Gennum's industry-leading programmable digital signal processing platform. SoundDesign Advanced Research is a Gennum developed methodology that couples state-of-the-art acoustic algorithms to ensure high-fidelity digital sound quality.

Venture's adaptive noise reduction preserves perceived speech levels without causing distortion. It monitors noise levels independently in 128 individual bands. This strategy also employs advanced psychoacoustic models to eliminate audible noise and reduce the amount of perceptible artifacts introduced by the noise reduction process.

Based on a phase cancellation method, Venture's adaptive feedback reduction algorithm provides increased maximum stable gain unlike other feedback strategies. Additionally, it features rapid adjustment for dynamic feedback situations and resistance to tonal inputs.

In addition to these adaptive algorithms, Venture also supports the following features: FRONTWAVE directional processing, cross fading between audio paths for click-free memory changes, 8-band graphic equalizer, 8 generic biquad filters (configurable as parametric or other filter types), programming speed enhancements, optional peak clipping, flexible compression adjustments, programmable tones for memory change and low battery indicators, wideband gain, volume control and industry-leading security features to avoid cloning and software piracy.

Available Venture configurations:

- GA3219: Adaptive noise reduction and adaptive feedback canceller
- GA3218: Adaptive noise reduction
- GA3217: Adaptive feedback canceller

Block Diagram

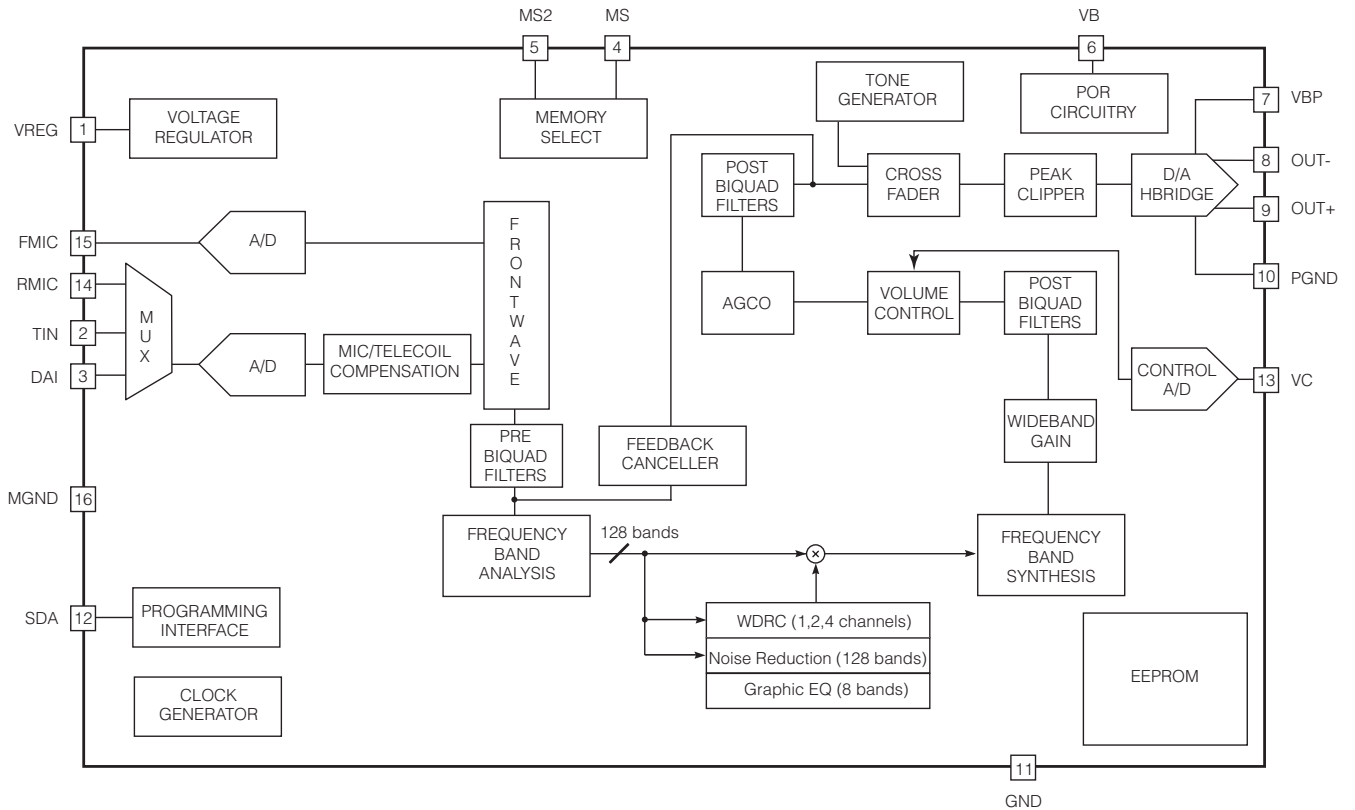

Hybrid block diagram

Contents

Features	1
thinSTAX PACKAGING.....	1
Description	1
1. Pad Connection.....	4
2. Absolute Maximum Rating	4
3. Electrical Characteristics.....	5
4. Typical Applications	7
5. Venture Overview.....	9
6. Signal Path.....	10
7. Functional Block Description.....	11
7.1 Adaptive Feedback Canceller	11
7.2 Adaptive Noise Reduction	11
7.3 A/D and D/A Converters	12
7.4 HRX Head Room Expander	12
7.5 FRONTWAVE Directionality	12
7.6 Channel Processing	13
7.7 Telecoil Path	14
7.8 Graphic Equalizer	14
7.9 Biquad Filters	14
7.10 Volume Control	15
7.11 AGCo and Peak Clipper	15
7.12 Memory Select Switches	16
7.12.1 Momentary Switch on MS.....	16
7.12.2 Momentary Switch on MS, Static Switch on MS2 (jump to last memory).....	16
7.12.3 Static Switch on MS and MS2	17
7.12.4 Static Switch on MS, Static Switch on MS2 (jump to last memory).....	17
7.13 Audible Memory Change Indicator	18
7.14 Tone Generator	19
7.15 Cross Fader	19
7.16 Power-On/Power-Off Behavior and Low Battery Indicator	19
7.17 Software And Security	21
7.18 SDA Communication	21
7.19 Power Management	21
8. Package Dimensions	22
8.1 Pad Location	23
9. Revision History	24

1. Pad Connection

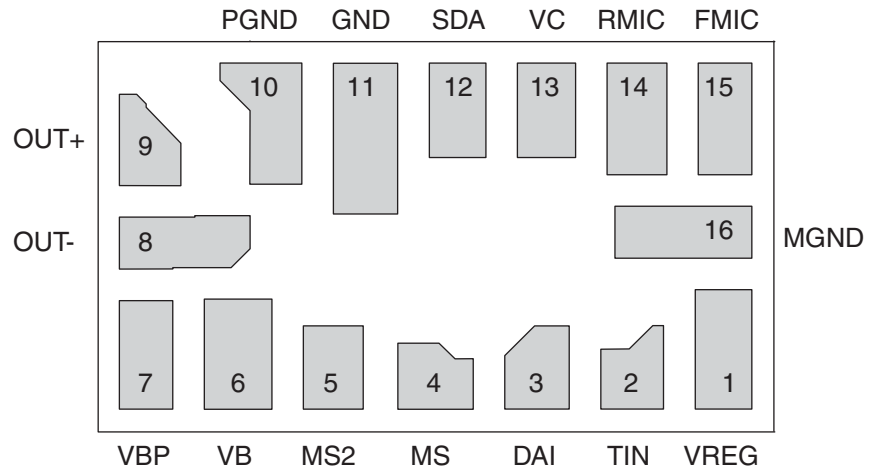

Figure 1-1: Pad Connection

2. Absolute Maximum Rating

Parameter	Value
Operating Temperature Range	0°C to 40°C
Storage Temperature Range	-20°C to 70°C
Absolute Maximum Power Dissipation	25mW
Maximum Operating Supply Voltage	1.5VDC
Absolute Maximum Supply Voltage	2VDC

3. Electrical Characteristics

Table 3-1: Electrical Characteristics

Conditions: $V_{BAT} = 1.25V$ Temperature = $25^{\circ}C$

Parameter	Symbol	Conditions	Min	Typ	Max	Units
Hybrid Current	I_{AMP}	With adaptive features 8kHz bandwidth	–	925	–	μA
	I_{AMP}	With adaptive features 16kHz bandwidth	–	1150	–	μA
Minimum Operating Supply Voltage	V_{BOFF}	Ramp down	0.93	0.95	0.97	V
Supply Voltage Turn On Threshold	V_{BON}	Ramp up	1.06	1.1	1.16	V
EEPROM Burn Cycles	–	–	100k	–	–	cycles
Low Frequency System Bandwidth	–	–	–	125	–	Hz
High Frequency System Bandwidth	–	32kHz sampling rate	–	16	–	kHz
Total Harmonic Distortion	THD	$V_{IN} = -40dBV$	–	–	1	%
THD at Maximum Input	THD_M	$V_{IN} = -15dBV$, HRX - ON	–	–	3	%
Clock Frequency	f_{clk}	–	1.945	2.048	2.151	MHz
Regulator						
Regulator Voltage	V_{REG}	–	0.87	0.90	0.93	V
Input						
Input Referred Noise	IRN	Bandwidth 100Hz - 8KHz	–	–	-106	dBV
Input Impedance	Z_{IN}	–	–	16	–	$k\Omega$
Anti-aliasing Filter Rejection	–	$f = f_{CLK} - 8kHz$, $V_{IN} = -40dBV$	–	80	–	dB
Maximum Input Level	–	–	–	-15	–	dBV
Input Dynamic Range	–	HRX - ON Bandwidth 100Hz - 8KHz	–	95	–	dB
A/D Dynamic Range	–	Bandwidth 100Hz - 8KHz	–	86	–	dB
Output						
D/A Dynamic Range	–	–	–	83	–	dBV
Output Impedance	Z_{OUT}	–	–	–	15	Ω

Table 3-1: Electrical Characteristics (Continued)

Conditions: $V_{BAT} = 1.25V$ Temperature = 25°C

Parameter	Symbol	Conditions	Min	Typ	Max	Units
Volume Control						
Volume Control Resistance	R_{VC}	Two-terminal connection	160	200	240	$k\Omega$
	R_{VC}	Three-terminal connection	100	–	1000	$k\Omega$
Volume Control Range	ΔA	–	–	42	–	dB
SDA Input						
Logic 0 Voltage	–	–	0	–	0.3	V
Logic 1 Voltage	–	–	1	–	1.3	V
SDA Output						
Standby Pull Up Current	–	–	1.4	2	2.6	μA
Sync Pull Up Current	–	–	450	500	550	μA
Logic 0 Current (Pull Down)	–	–	225	250	275	μA
Logic 1 Current (Pull Up)	–	–	225	250	275	μA
Synchronization Time (Synchronization Pulse Width)	T_{SYNC}	Baud = 0	237	250	263	μs
	T_{SYNC}	Baud = 1	118	125	132	μs
	T_{SYNC}	Baud = 2	59	62.5	66	μs
	T_{SYNC}	Baud = 3	29.76	31.25	32.81	μs
	T_{SYNC}	Baud = 4	14.88	15.63	16.41	μs
	T_{SYNC}	Baud = 5	7.44	7.81	8.20	μs
	T_{SYNC}	Baud = 6	3.72	3.91	4.10	μs
	T_{SYNC}	Baud = 7	1.86	1.95	2.05	μs
MS Input						
Pull Down Resistance	–	–	–	1	–	$M\Omega$
Logic 1 Voltage	–	–	V_{REG}	–	V_B	V
Rising Edge Threshold	–	–	0.5	0.69	0.9	V
Falling Edge Threshold	–	–	0.25	0.45	0.5	V
Hysteresis	–	–	0.1	0.24	0.4	V

Table 3-1: Electrical Characteristics (Continued)

Conditions: $V_{BAT} = 1.25V$ Temperature = 25°C

Parameter	Symbol	Conditions	Min	Typ	Max	Units
MS2 Input						
Pull Down Resistance	-	-	-	1	-	MΩ
Logic 1 Voltage	-	-	V_{REG}	-	V_B	V
Rising Edge Threshold	-	-	0.5	0.69	0.9	V
Falling Edge Threshold	-	-	0.25	0.45	0.5	V
Hysteresis	-	-	0.1	0.24	0.4	V

4. Typical Applications

All resistors in ohms, all capacitors in farads unless otherwise stated.

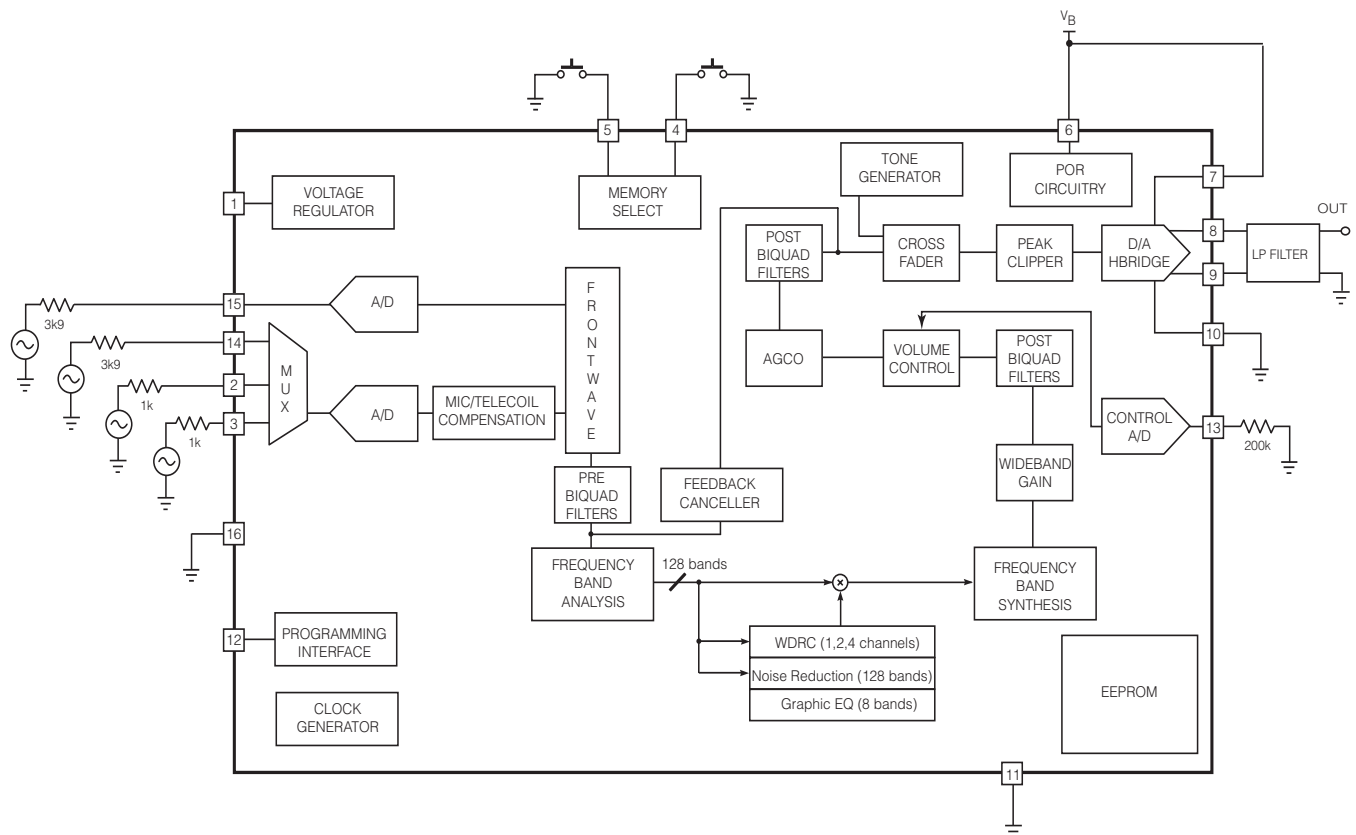

Figure 4-1: Test Circuit

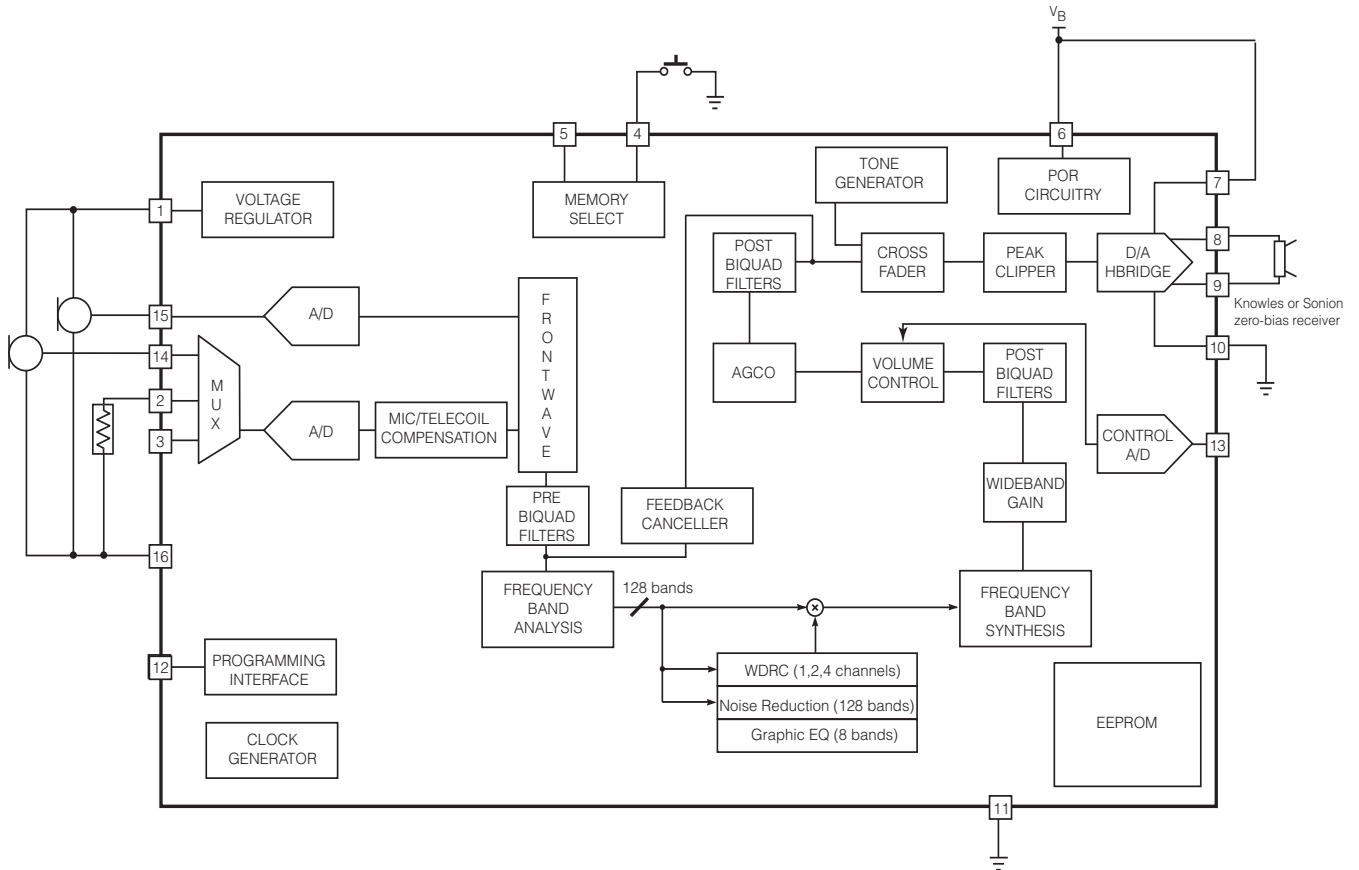

Figure 4-2: Typical Application Circuit

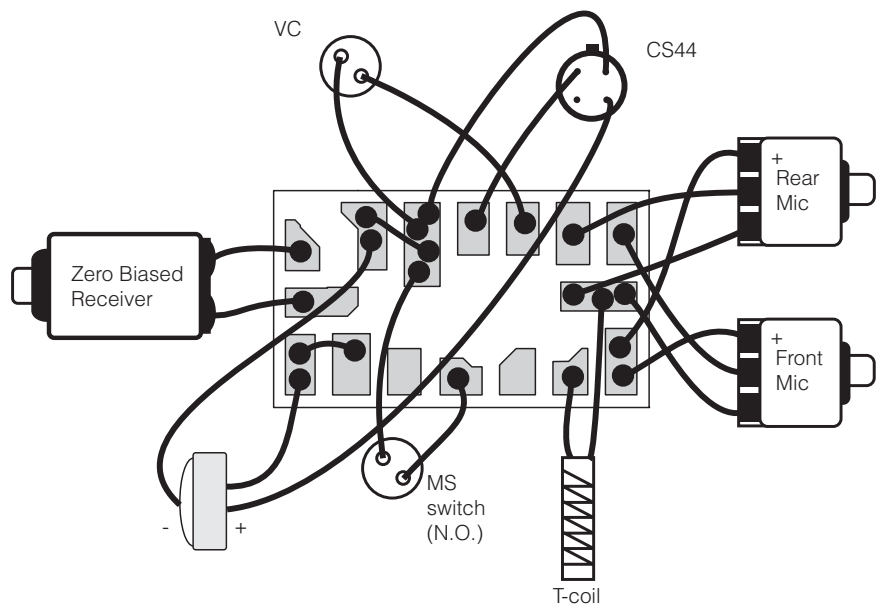

Figure 4-3: Typical Hearing Instrument Assembly Diagram

5. Venture Overview

Venture Digital is a DSP system with adaptive algorithms that run on the Voyager™ hardware platform. This hardware platform is a combination of a DSP core and a high fidelity audio CODEC. As well, thinSTAX packaging provides easy integration into a wide range of applications from CIC to BTE.

The audio functions implemented on the CODEC include tone generation, peak clipping and cross fading between audio paths. The DSP core implements FRONTWAVE directional processing, programmable filters, adaptive algorithms, compression, wideband gain, and volume control. The adaptive algorithms include Adaptive Noise Reduction and Adaptive Feedback Cancellation. The Adaptive Noise Reduction reduces audible noise in a low distortion manner while preserving perceived speech levels. The Adaptive Feedback Canceller reduces acoustic feedback while offering robust performance against pure tones. As well, Venture contains security features to protect clients' Intellectual Property against device cloning and software piracy.

Venture utilizes the power and capabilities of Voyager to deliver advanced features and enhanced performance previously unavailable to a product in its class.

This data sheet is part of a set of documents available for this product. Please refer to "Getting Started with Venture Digital", document #33350, for a list of other documents.

6. Signal Path

There are two main audio input signal paths. The first path contains the Front Microphone and second path contains the Rear Microphone, Telecoil or Direct Audio input as selected by a programmable MUX. The front microphone input is intended as the main Microphone audio input for single microphone applications. In FRONTWAVE operation, a multimicrophone signal is used to produce a directional hearing instrument response. The two audio inputs are buffered, sampled and converted into digital form using dual A/D converters. The digital outputs are converted into a 32kHz or 16kHz, 20-bit digital audio signal.

Further IIR filter blocks process the front microphone and rear microphone signals. One biquad filter is used to match the rear microphone's gain to that of the front microphone. After that, another filter is used to provide an adjustable group delay to create the desired polar response pattern during the calibration process.

In the Telecoil mode gains are trimmed during Cal/Config process to compensate for microphone/telecoil mismatches.

The FRONTWAVE block is followed by four cascaded biquad filters: "pre1", "pre2", "pre3" and "pre4". These filters can be used for frequency response shaping before the signal goes through channel and adaptive processing.

The channel and adaptive processing consists of

- frequency band analysis
- 1, 2 or 4 channel WDRC
- 8 logarithmically spaced band frequency shaping (graphic EQ)
- 128 frequency band adaptive noise reduction
- frequency band synthesis
- phase cancellation adaptive feedback reduction

After the processing the signal goes through two more biquad filters, "post1" and "post2", the Wideband Gain and Volume Control.

These biquad filters are followed by the AGCo block, two more biquad filters, post3" and "post4", and the Peak Clipper. The last stage in the signal path is the D/A H-bridge.

7. Functional Block Description

7.1 Adaptive Feedback Canceller

The Adaptive Feedback canceller (AFC) reduces acoustic feedback by forming an estimate of the hearing aid feedback signal and then subtracting this estimate from the hearing aid input. Therefore the forward path of the hearing aid is not affected. Unlike adaptive notch filter approaches, Venture's AFC does not reduce the hearing aid's gain. The AFC is based on a time-domain model of the feedback path.

Venture's second generation AFC exhibits greatly improved resistance to tonal inputs.

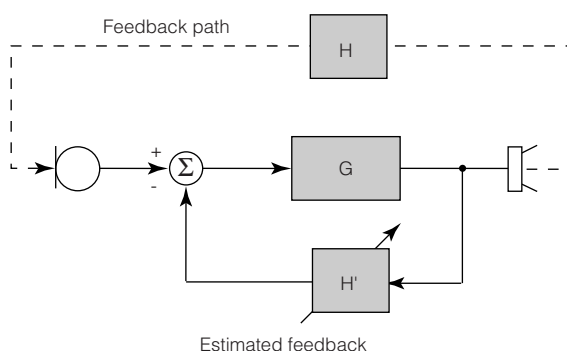

Figure 7-1: Adaptive Feedback Canceller (AFC) block diagram

7.2 Adaptive Noise Reduction

The noise reduction algorithm is built upon a high resolution 128-band filterbank enabling precise removal of noise. The algorithm monitors the signal and noise activities in these bands, and imposes a carefully calculated attenuation gain independently in each of the 128 bands.

The noise reduction gain applied to a given band is determined by a combination of three factors:

- Signal-to-Noise Ratio (SNR)
- Masking threshold
- Dynamics of the SNR per band.

The SNR in each band determines the maximum amount of attenuation that will be applied to the band; the poorer the SNR, the greater the amount of attenuation. Simultaneously, in each band, the masking threshold variations resulting from the energy in other adjacent bands is taken into account. Finally, the noise reduction gain is also adjusted to take advantage of the natural masking of 'noisy' bands by speech bands over time.

Based on this approach, only enough attenuation is applied to bring the energy in each 'noisy' band to just below the masking threshold. This prevents excessive amounts of attenuation from being applied and thereby reduces unwanted artifacts

and audio distortion. The Noise Reduction algorithm efficiently removes a wide variety of types of noise, while retaining natural speech quality and level.

7.3 A/D and D/A Converters

The system's two A/D converters are 2nd-order sigma-delta modulators, which operate at a 2.048MHz sample rate. The system's two audio inputs are pre-conditioned with antialias filtering and programmable gain pre-amplifiers. These analog outputs are over sampled and modulated to produce two, 1-bit pulse density modulated (PDM) data streams. The digital PDM data is then decimated down to pulse-code modulated (PCM) digital words at the system sampling rate of 32kHz.

The D/A is comprised of a digital, 3rd-order sigma-delta modulator and an H-bridge. The modulator accepts PCM audio data from the DSP path and converts it into a 32-times over-sampled, 1-bit PDM data stream, which is then supplied to the H-bridge. The H-bridge is a specialized CMOS output driver used to convert the 1-bit data stream into a low-impedance, differential output voltage waveform suitable for driving zero-biased hearing aid receivers.

7.4 HRX Head Room Expander

Venture has an enhanced Head Room Expander (HRX) circuit, which increases the input dynamic range of Venture without any audible artifacts. This is accomplished by dynamically adjusting the preamplifier's gain and the post-A/D attenuation depending on the input level.

7.5 FRONTWAVE Directionality

The FRONTWAVE block provides the resources necessary to implement directional microphone processing. The block accepts inputs from both a front and rear microphone and provides a synthesized directional microphone signal as its output. The directional microphone output is obtained by delaying the rear microphone signal and subtracting it from the front microphone signal. Various microphone response patterns can be obtained by adjusting the time delay.

The FRONTWAVE circuit also provides a fixed filter for compensating the sensitivity and frequency response differences between microphones. The filter parameters are adjusted during product calibration.

A dedicated biquad filter following the FRONTWAVE block has been allocated for low frequency equalization to compensate for the 6dB/octave roll off in frequency response that occurs in directional mode. The amount of low frequency equalization that is applied can be determined during product calibration.

Gennum recommends using matched microphones with FRONTWAVE, although calibration is fully possible using unmatched microphones.

7.6 Channel Processing

Figure 7-2 represents the I/O characteristic of independent AGC channel processing. The I/O curve can be divided into four main regions:

- low input level expansion (squelch) region
- low input level linear region
- compression region
- high input level linear region (return to linear)

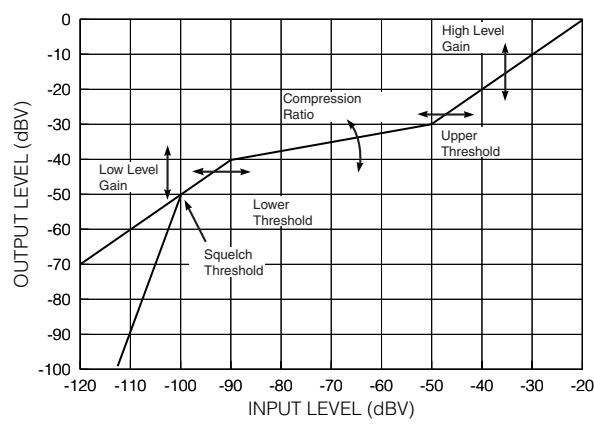

Figure 7-2: Independent Channel I/O Curve Flexibility

The I/O characteristic of the channel processing can be adjusted in six ways:

- squelch threshold (SQUELCHTH)
- low level gain (LLGAIN)
- lower threshold (LTH)
- high level gain (HLGAIN)
- upper threshold (UTH)
- compression ratio (CR)

To ensure that the I/O characteristics are continuous it is necessary to limit adjustment to a maximum of four of the available five parameters. During Parameter Map creation it is necessary to select four parameters as user adjustable (or fixed) and allow one parameter to be calculated.

The squelch region within each channel implements a low level noise reduction scheme (1:2 or 1:3 expansion ratio) for listener comfort. This scheme operates in quiet listening environments (programmable threshold) to reduce the gain at very low levels.

The number of compression channels is programmable in ARKonline and can be 1, 2 or 4.

7.7 Telecoil Path

The telecoil input is calibrated during the Cal/Config process. To compensate for the telecoil/microphone frequency response mismatch, a first order filter with 500Hz corner frequency is implemented. Through ARKonline it is possible to implement a telecoil compensation filter with an adjustable corner frequency. To accommodate for the gain mismatch, the telecoil gain is adjusted to match the microphone gain at 500Hz or 1kHz (default) and is selectable in ARKonline.

There is also a telecoil gain adjustment parameter, which can be enabled in ARKonline and set in IDS that will allow for manual adjustment of the telecoil gain compensation.

7.8 Graphic Equalizer

Venture has an 8 band graphic equalizer. The bands are spaced logarithmically, and each one provides up to 24dB of gain adjustment in 1dB increments.

7.9 Biquad Filters

Additional frequency shaping can be achieved by configuring generic biquad filters. The transfer function for each of the biquad filters is as follows:

$$H(z) = \frac{b_0 + b_1 * z^{-1} + b_2 * z^{-2}}{1 + a_1 * z^{-1} + a_2 * z^{-2}}$$

Note that the a0 coefficient is hard-wired to always be a 1. The coefficients are each 16 bits in length and include one sign bit, one bit to the left of the decimal point, and 14 bits to the right of the decimal point. Thus, before quantization, the floating-point coefficients must be in the range

-2.0 <= x < 2.0 and quantized with the function:

$$\text{round}(x * 214)$$

After designing a filter, the quantized coefficients can be entered into the PreBiquads or PostBiquads tab in the Interactive Data Sheet. The coefficients b0, b1, b2, a1, and a2 are as defined in the transfer function above. The parameters meta0 and meta1 do not have any effect on the signal processing, but can be used to store additional information related to the biquad with which they are associated.

The underlying code in the product components automatically checks all of the filters in the system for stability (that is, the poles have to be within the unit circle) before updating the graphs on the screen or programming the coefficients into the hybrid. If the Interactive Data Sheet receives an exception from the underlying stability checking code, it will automatically disable the biquad being modified and display a warning message. When the filter is made stable again, it can be re-enabled.

Note also that in some configurations some of these filters may be used by the product component for microphone/telecoil compensation, low-frequency EQ, etc. If this is the case, the coefficients the user enters into IDS will be ignored and the filter designed by the software will be programmed instead. For more information on filter design refer to [Biquad Filters In PARAGON™ Digital Hybrid](#) information note, Document # 20205.

7.10 Volume Control

The volume control (VC) can be either external or programmable. If VC is programmed for external operation, a variable resistor should be connected to the 9bit A/D converter.

The external VC can be configured to work with either a two-terminal 200k Ω variable resistor or a three-terminal 0.1M Ω –1M Ω variable resistor. In two-terminal configuration the VC is connected between GND and the VC input and in three-terminal configuration between GND, Vreg and the VC input.

If using two terminal VC, it must be calibrated before use. Calibration is not necessary with three terminal connection. Hysteresis is built into the Volume Control circuitry to prevent unintentional volume level toggling. A log taper potentiometer is recommended so that gain in dB would be linear with potentiometer rotation. The VC has 42dB of range.

7.11 AGCo and Peak Clipper

The output compression-limiting block (AGCo) is an output limiting circuit whose compression ratio is fixed at ∞ :1. The threshold level is programmable. The AGCo module has programmable attack and release time constants.

The AGCo on Venture has optional adaptive release functionality. When this function is enabled the release time varies depending on the environment. In general terms the release time becomes faster in environments where the average level is well below the threshold and only brief intermittent transients exceed the threshold.

Conversely, in environments where the average level is close to the AGCo threshold the release time applied to portions of the signal exceeding the threshold is longer. The result is an effective low distortion output limiter that clamps down very quickly on momentary transients but reacts more smoothly in loud environments to minimize compression pumping artifacts. The programmed release time is the longest release time applied while the fastest release time is 16 times faster than this. For example if a release time of 128ms is selected the fastest release time applied by the AGCo block is 8ms.

For added flexibility, Venture also has the Peak Clipper block.

7.12 Memory Select Switches

There are two, two-pole Memory Select switches available on Venture, which allows the user tremendous flexibility in switching between configurations. These switches may be either momentary or static and are configurable to be either pull-up or pull-down through the settings tab in IDS.

Up to four memories can be configured on Venture. Memory A must always be valid. All memory select options are selectable via the settings tab in IDS.

7.12.1 Momentary Switch on MS

This mode uses a single momentary switch on MS (Pin 4) to change memories. Using this mode will cause the part to start in Memory A and whenever the button is pressed the next valid memory will be loaded. When the user is in the last valid memory, a button press will cause memory A to be loaded.

This mode is set by programming the "MSSMode" parameter to "Momentary" and "Donly" to "disabled".

Examples

If 4 valid memories ABCDABCD...A...

If 3 valid memories ABCABCA...A...

If 2 valid memories ABABA...A...

If 1 valid memories AAA...A...

7.12.2 Momentary Switch on MS, Static Switch on MS2 (jump to last memory)

This mode uses a static switch on MS2 (Pin 5) and a momentary switch on MS (Pin 4) to change memories. If the static switch is OPEN, the part will start in memory A and it will behave like momentary with the exception memory D will not be used. If the static switch on MS2 is set to HIGH, the part will automatically jump to memory D (this will happen on startup or during normal operation). In this setup, the momentary switch's state is ignored. This prevents memory select beeps from occurring. When MS2 is set to OPEN, the part will load in the last select memory.

This mode is set by programming the "MSSMode" parameter to "Momentary" and "Donly" to "enabled".

Examples

If MS2 = OPEN and there are 4 valid memories: ABCABCA...A...

If MS2 = OPEN and there are 3 valid memories: ABABA...A...

If MS2 = HIGH: D...A...

Table 7-1: Dynamic example with 4 valid memories

T = momentary switch is toggled, 0 = OPEN, 1 = HIGH

MS2	0	0	0	1	1	1	0	0	0	1	0	0	0	0	0	0
MS	0	T	T	0	T	T	0	T	T	0	0	T	T	T	T	T
Memory	A	B	C	D	D	D	C	A	B	D	B	C	A	B	C	A

7.12.3 Static Switch on MS and MS2

This mode uses two static switches to change memories.

Table 7-2 describes which memory is selected depending on the state of the switches.

In this mode it is possible to jump from any memory to any other memory simply by changing the state of both switches. If both switches are changed simultaneously then the transition will be smooth, otherwise, if one switch is changed and then the other, the part will transition to an intermediate memory before reaching the final memory.

The part will start in whatever memory the switches are selecting. If a memory is invalid the part will default to memory A.

This mode is set by programming the “MSSMode” parameter to “static” and “Only” to “disabled”.

Table 7-2: Memory selected in Static Switch on MS and MS2 mode

MS	MS2	Memory
OPEN	OPEN	A
HIGH	OPEN	B (if valid, otherwise A)
OPEN	HIGH	C (if valid, otherwise A)
HIGH	HIGH	D (if valid, otherwise A)

7.12.4 Static Switch on MS, Static Switch on MS2 (jump to last memory)

This mode uses two static switches to change memories. Unlike in the previous example, this mode will switch to the last valid memory when the static switch on MS2 is HIGH. This means that this mode will only use a maximum of three memories (even if four valid memories are programmed). Table 7-3 describes which memory is selected depending on the state of the switches.

This mode is set by programming the “MSSMode” parameter to “static” and “Only” to “enabled”.

Table 7-3: Memory selected in Static Switch on MS, Static Switch on MS2 (jump to last memory) mode

MS	MS2	Memory
OPEN	OPEN	A
HIGH	OPEN	B (if valid, otherwise A)
OPEN	HIGH	D
HIGH	HIGH	D

In this mode it is possible to jump from any memory to any other memory simply by changing the state of both switches. If both switches are changed simultaneously then the transition will be smooth, otherwise, if one switch is changed and then the other, the part will transition to an intermediate memory before reaching the final memory.

When MS2 is set HIGH, the state of the switch on MS is ignored. This prevents memory select beeps from occurring when switching MS when MS2 is HIGH.

The part will start in whatever memory the switches are selecting. If a memory is invalid, the part will default to memory A.

7.13 Audible Memory Change Indicator

Venture can be programmed to produce tones to indicate a memory change. Using the Interactive Data Sheet Venture can be configured to either enable or disable the Memory Change Indicator.

When the Memory Change Indicator is enabled, there is an option to have a single beep for each memory change or multiple beeps.

The amplitude and frequency of the memory change tone can be selected independent of the Tone Generator settings and can be individually selected for each memory. When the memory change multiple beep is enabled and the memory change tone is enabled, then during a memory change operation the selected tone will beep a code to indicate which memory has been selected. The beep sequence will be 160ms ON followed by a 160ms OFF time between the beeps. The memory change beeping code is deciphered in [Table 7-4](#).

Table 7-4: The memory change beeping code

Selected Memory	Number of Beeps
A	1
B	2
C	3
D	4

7.14 Tone Generator

The programmable tone generator is capable of producing programmable tones. Upon reception of the tone enable instruction, the Venture connects the output of the tone generator to the input of the D/A converter. The programmed tone is then output until a tone disable instruction is issued. When disabled, the normal audio signal is again connected.

7.15 Cross Fader

To minimize potential loud transients when switching between memories, Venture uses a cross fader block. When the memory is changed, the audio signal is faded out, followed by the memory select indicator beeps (if enabled), and after switching to the next memory, the audio signal is faded back in. The cross fader is also used when turning the Tone Generator on or off, and during SDA programming.

7.16 Power-On/Power-Off Behavior and Low Battery Indicator

During power-on, the Venture hybrid is held in a reset state until the supply voltage (V_b) reaches a turn-on threshold. A small portion of the hybrid's internal control logic turns on and monitors the voltage to determine if the supply is stable. Once the supply is stable, the entire hybrid is activated and loads its configuration. Finally, the audio output turns on by smoothly transitioning to the expected output level.

During normal operation, when a low battery condition (below turn on threshold) is detected, the Venture hybrid sends out a series of one to seven beeps (each beep is 512ms ON and 512ms OFF) to indicate the battery is low. This will repeat every five minutes until the device reaches the turn-off threshold.

The low battery threshold is programmable in IDS between 1.0V and 1.2V in 10mV increments.

If V_b drops below the turn-off threshold then the Venture hybrid is returned to its reset state and the audio output is muted. After a reset due to a low battery or a sudden supply transient, the recovery behavior of Venture is determined by the selectable reset mode through ARKonline.

There are four selectable reset modes as follows:

1. Shallow-reset mode, which after a low battery shutdown or transient shutdown, will allow the Venture hybrid to immediately restart when the supply voltage rises above the turn-ON threshold. The device will restart in the memory that was last active when the shut down occurred. In summary, the device will function until the supply voltage drops below the turn-OFF threshold, and will recover when the device rises above the turn-ON threshold again.
2. Deep-reset mode, which after a low battery shutdown or transient shutdown, will not allow the Venture hybrid to restart. Once a shut down occurs (i.e. once the supply voltage drops below the turn-OFF threshold), the device remains off until the supply voltage drops below approximately 0.3V and subsequently rises above the turn-ON threshold. In order for the supply to drop below 0.3V, the battery should be disconnected. Upon reconnecting the battery (preferably a new battery) the supply voltage will rise above the turn-ON threshold, and subject to the supply being stable, the device will restart.
3. Mixed mode, which is a combination of modes 1 and 2. The device starts up in shallow-reset mode initially, then changes over to deep reset mode after five minutes.
4. Transient reboot mode (recommended), which is a more advanced combination of modes 1 and 2, plus some additional intelligence. The device starts up in shallow-reset mode initially, so that after a low battery shutdown or transient shutdown, the device immediately restarts when the supply voltage rises above the turn-ON threshold. Once the device restarts, deep-reset mode is applied and the device operates in the memory that was last active when the shut down occurred. Additionally, the maximum output level is reduced through a 2 dB reduction of the AGCo and peak clipper. This operating condition is defined as transient reboot mode. The device operates in transient reboot mode (meaning deep-reset mode and maximum output reduction are applied) while monitoring the supply voltage. If the supply voltage remains above the turn-on threshold for at least 30 seconds, the device is allowed to exit transient reboot mode. The device returns to shallow-reset mode and the maximum output is restored.

Generally, any low battery shutdown or transient shutdown that occurs while in shallow-reset mode (or while in the shallow-reset mode component of mixed mode or transient reboot mode) will result in the Venture hybrid restarting into the memory that was last active when the shut down occurred. The Venture hybrid has this memory restart capability for up to three memories. A restart in any memory beyond the first three memories will cause the device to restart in the initial memory, similar to the behavior when a battery is first connected. The transient reboot mode described above also applies to up to three memories. Any additional memories will use the shallow-reset mode behavior, and will restart in the initial memory after a shutdown.

In any of the above reset modes, the Venture hybrid can be configured through ARKonline to reduce the gain as the battery voltage drops. When the supply voltage falls below the low battery threshold, low battery tones will be emitted and the wideband gain will be reduced by 3dB. As the battery voltage continues to drop, the low battery tones will continue and the wideband gain will continue to be reduced. Once the turn-OFF threshold is reached, the device will shut down.

7.17 Software And Security

Venture incorporates security features to protect the device from cloning and against software piracy. These features are:

1. DLL protection by password — this prevents a third party from using IDS to reconfigure parts.
2. Hybrid authentication by 128-bit fingerprint to identify parts in application software — this prevents a third party from cloning a device's EEPROM, since the fingerprint can not be overwritten. Special functions can be used in fitting software to reject parts that do not match the expected fingerprint. This will prevent the piracy of fitting software.
3. DLL to hybrid pairing by using a software key in ARK to match product libraries with client software. A part can be "locked" at manufacturing time so that it will only communicate with the library it was programmed with. This prevents a third party from potentially upgrading a device with a different library in IDS or other application software.

Full software support is provided for every stage of development from design to manufacturing to fitting. Please refer to the [Getting Started with ARK Guide](#), document #27217.

7.18 SDA Communication

Venture is programmed via the SDA pin using industry standard programming boxes. During parameter changes the main audio signal path of the hybrid is temporarily muted using the cross fader to avoid the generation of disturbing audio transients. Once the changes are complete, the main audio path is reactivated.

Any changes made during programming will be lost at power-off unless they are explicitly burned to EEPROM memory.

Improvements have been made to the ARK software for Venture, which will increase communication speed. Certain parameters in ARKonline can be selected in such a way as to reduce the number of pages that need to be read out.

7.19 Power Management

Venture was designed to accommodate high power applications. AC ripple on the supply can cause instantaneous reduction of the battery's voltage, potentially disruption the circuit's function. Venture hybrids have a separate power supply and ground connections for the output stage. This allows hearing instrument designers to accommodate external RC filters in order to minimize any AC ripple from the supply line. Reducing this AC ripple greatly improves the stability of the circuit and prevents unwanted reset of the circuit caused by spikes on the supply line. For more information on properly designing a filter to reduce supply ripple, please refer to information note [Using the GB3211 PARAGON Digital in High Power Applications Initial Design Tips](#), document #24561.

8. Package Dimensions

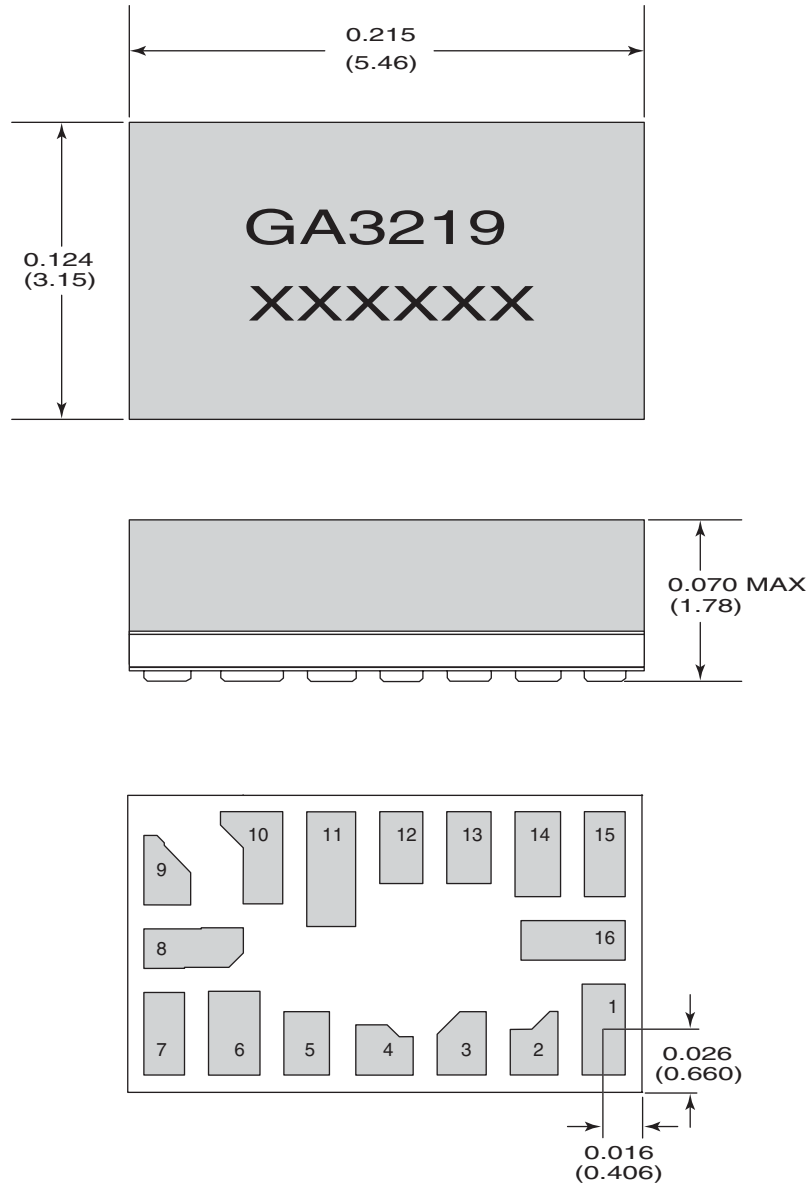

Dimension units are in inches.

Dimensions in parentheses are in millimetres, converted from inches and include minor rounding errors.

1.0000 inches = 25.400mm

Dimension tolerances: ± 0.005 (± 0.13) unless otherwise stated.

Work order number: XXXXXX

This Hybrid is designed for either point-to-point manual soldering or for reflow according to Gennum's reflow process (Information Note 521-45).

Figure 8-1: Package dimensions

8.1 Pad Location

Pad No.	Pad Position		Pad Dimensions	
	X	Y	Xdim (MIL)	Ydim (MIL)
1	0	0	18	38
2	-29	-5.75	20	26.5
3	-59.25	-5.75	20.5	26.5
4	-91.5	-8.5	24	21
5	-124	-5.75	19	26.5
6	-154.25	-1.75	21.5	34.5
7	-183.5	-1.75	17	34.5
8	-171.25	33.75	41.5	16.5
9	-182.25	66.5	19.5	29
10	-147	71.5	26	39
11	-113.75	66.5	20.5	49
12	-84.5	76	18	30
13	-56.25	76	18.5	30
14	-27.25	73.25	18.5	35.5
15	0.5	73.25	17	35.5
16	-12.75	37.25	43.5	16.5
Pad No.	X	Y	Xdim (mm)	Ydim (mm)
1	0	0	0.457	0.965
2	-0.737	-0.146	0.508	0.673
3	-1.505	-0.146	0.521	0.673
4	-2.324	-0.216	0.610	0.533
5	-3.150	-0.146	0.483	0.673
6	-3.918	-0.044	0.546	0.876
7	-4.661	-0.044	0.432	0.876
8	-4.350	0.857	1.054	0.419
9	-4.629	1.689	0.495	0.737
10	-3.734	1.816	0.660	0.991
11	-2.889	1.689	0.521	1.245
12	-2.146	1.930	0.457	0.762
13	-1.429	1.930	0.470	0.762
14	-0.692	1.861	0.470	0.902
15	0.013	2.007	0.432	0.902
16	-0.324	0.946	1.105	0.419

9. Revision History

Version	ECR	Date	Changes and / or Modifications
0	134601	October 2004	New document.
1	134970	December 2004	Updated to Preliminary Data Sheet.
2	135826	February 2005	Hybrid pads dimensions changed.

CAUTION

ELECTROSTATIC SENSITIVE DEVICES
DO NOT OPEN PACKAGES OR HANDLE
EXCEPT AT A STATIC-FREE WORKSTATION



DOCUMENT IDENTIFICATION
PRELIMINARY DATA SHEET

The product is in a preproduction phase and specifications are subject to change without notice.

GENNUM CORPORATION

Mailing Address: P.O. Box 489, Stn. A, Burlington, Ontario, Canada L7R 3Y3
Shipping Address: 970 Fraser Drive, Burlington, Ontario, Canada L7L 5P5
Tel. +1 (905) 632-2996 Fax. +1 (905) 632-5946

GENNUM JAPAN CORPORATION

Shinjuku Green Tower Building 27F, 6-14-1, Nishi Shinjuku, Shinjuku-ku, Tokyo, 160-0023 Japan
Tel. +81 (03) 3349-5501, Fax. +81 (03) 3349-5505

GENNUM UK LIMITED

25 Long Garden Walk, Farnham, Surrey, England GU9 7HX
Tel. +44 (0)1252 747 000 Fax +44 (0)1252 726 523

Gennum Corporation assumes no liability for any errors or omissions in this document, or for the use of the circuits or devices described herein. The sale of the circuit or device described herein does not imply any patent license, and Gennum makes no representation that the circuit or device is free from patent infringement.

GENNUM and the G logo are registered trademarks of Gennum Corporation.

© Copyright 2004 Gennum Corporation. All rights reserved. Printed in Canada.

www.gennum.com