



M/A-COM

DP52-0004

# Low Cost SMT Dual Band Diplexer 400-700/1100-1940 MHz



## Features

- Small Size and Low Profile
- Industry Standard SOW-16 SMT Plastic Package
- Superior Repeatability
- Passbands 400-700 MHz and 1100-1940 MHz
- Typical Passband Insertion Loss: 0.5 dB
- 2 Watt Power Handling
- Low Cost

## SOW-16

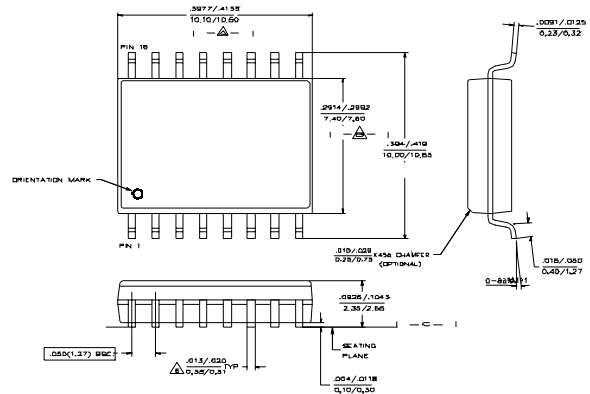

16-Lead SDP outline dimensions  
Wide body (.300)  
(All dimensions per JEDEC No. MS-013-AA, Issue C)  
Dimensions in  $\varnothing$  are in mm.  
Unless Otherwise Noted: .xxx =  $\pm 0.010$  (.xx =  $\pm 0.25$ )  
.xx =  $\pm 0.02$  (x =  $\pm 0.5$ )

## Description

M/A-COM's DP52-0004 is an IC-based monolithic Diplexer in a low cost SOW-16 plastic package. This Diplexer is ideally suited for applications where small size, low insertion loss, superior repeatability and low cost are required. Typical applications include WMT/PCS and dual mode portable devices.

The DP52-0004 is fabricated using a passive-integrated circuit process. The process features full-chip passivation for increased performance and reliability.

## Ordering Information

Part Number	Package
DP52-0004	SOW-16 Lead Plastic Package
DP52-0004-TR	Forward Tape and Reel <sup>1</sup>

1. If specific reel size is required, consult factory for part number assignment.

## 400MHz/1100-1940MHz Typical Electrical Specifications<sup>1</sup>, T<sub>A</sub> = +25°C

Parameter	Units	Min	Typ	Max
Passband Insertion Loss	dB	—	1.8	2.8
Stopband Isolation	dB	21	30	—
Passband VSWR	—	—	1.88	2.06

1. All specifications apply with a 50-Ohm source and load impedance.



M/A-COM Division of AMP Incorporated ■ North America: Tel. (800) 366-2266, Fax (800) 618-8883 ■ Asia/Pacific: Tel. +85 2 2111 8088, Fax +85 2 2111 8087 ■ Europe: Tel. +44 (1344) 869 595, Fax+44 (1344) 300 020

www.macom.com

AMP and Connecting at a Higher Level are trademarks.  
Specifications subject to change without notice.

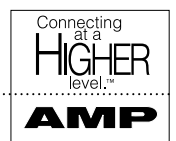

V1.00

**Absolute Maximum Ratings<sup>1</sup>**

Parameter	Absolute Maximum
Input Power	2 W CW
Operating Temperature	-40°C to +85°C
Storage Temperature	-65°C to +150°C

1. Exceeding these limits may cause permanent damage.

**Functional Diagram**

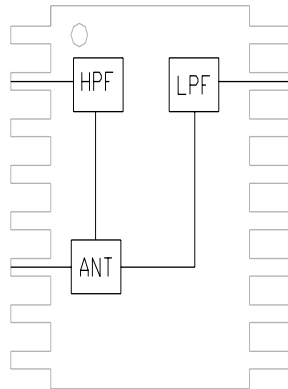

**Recommended PCB Configuration**

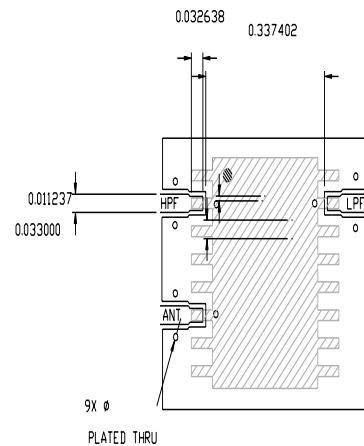

DP52-0004-G PCB LAYOUT (SDIC-16 CASE)  
 SCALE: 1X  
 CIRCUIT MATERIAL: FR4, .028 THICK  
 ALL PORTS ARE 50 OHMS

**Typical Performance @ +25°C**

**Insertion Loss vs Frequency**

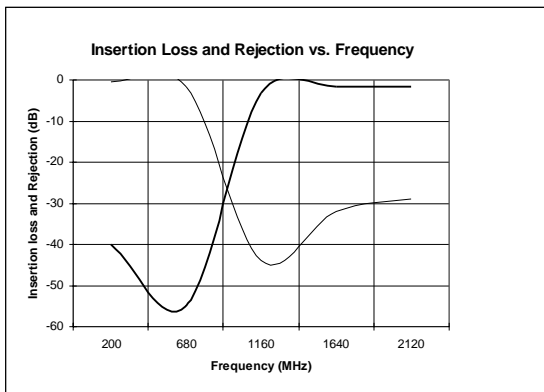

**VSWR vs Frequency**

