

DATA SHEET

ETD59/31/22

ETD cores and accessories

Supersedes data of September 2004

2008 Sep 01



FERROXCUBE
A YAGEO COMPANY

CORE SETS

Effective core parameters

SYMBOL	PARAMETER	VALUE	UNIT
$\Sigma(l/A)$	core factor (C1)	0.378	mm ⁻¹
V_e	effective volume	51500	mm ³
l_e	effective length	139	mm
A_e	effective area	368	mm ²
A_{min}	minimum area	360	mm ²
m	mass of core half	≈130	g

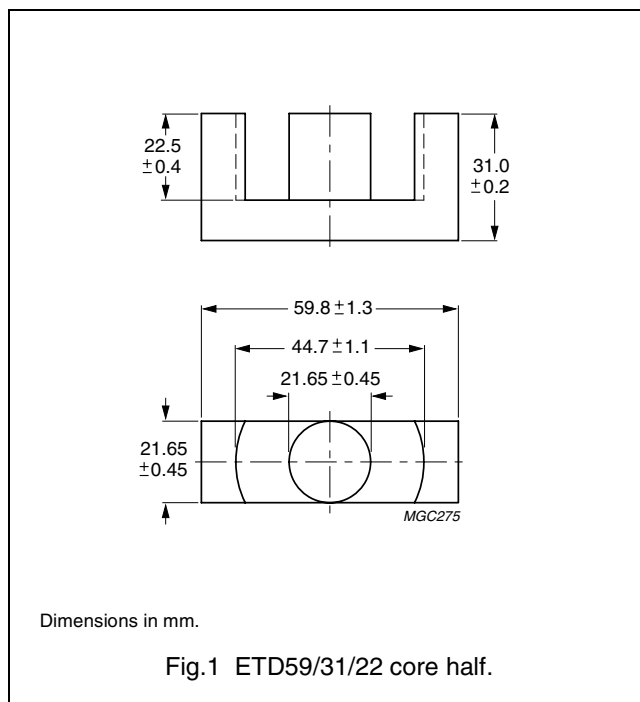

Core halves

Clamping force for A_L measurements, 70 ±20 N. Gapped cores are available on request.

GRADE	A_L (nH)	μ_e	AIR GAP (μm)	TYPE NUMBER
3C90	6000 ±25%	≈ 1800	≈ 0	ETD59/31/22-3C90
3C94	6000 ±25%	≈ 1800	≈ 0	ETD59/31/22-3C94
3C95 des	7340 ±25%	≈ 2205	≈ 0	ETD59/31/22-3C95
3F3	5600 ±25%	≈ 1680	≈ 0	ETD59/31/22-3F3

Properties of core sets under power conditions

GRADE	B (mT) at	CORE LOSS (W) at				
	H = 250 A/m; f = 25 kHz; T = 100 °C	f = 25 kHz; \hat{B} = 200 mT; T = 100 °C	f = 100 kHz; \hat{B} = 100 mT; T = 100 °C	f = 100 kHz; \hat{B} = 200 mT; T = 25 °C	f = 100 kHz; \hat{B} = 200 mT; T = 100 °C	f = 400 kHz; \hat{B} = 50 mT; T = 100 °C
3C90	≥330	≤ 6.2	≤ 7.3	–	–	–
3C94	≥330	–	≤ 5.2	–	≤ 31	–
3C95	≥330	–	–	≤ 32.4	≤ 30.9	–
3F3	≥320	–	≤ 6.7	–	–	≤ 12.8

COIL FORMER

General data 24-pins ETD59/31/22 coil former

PARAMETER	SPECIFICATION
Coil former material	polybutyleneterephthalate (PBT), glass-reinforced, flame retardant in accordance with "UL 94V-0"; UL file number E45329(M)
Pin material	copper-tin alloy (CuSn), tin (Sn) plated
Maximum operating temperature	155 °C, "IEC 60085", class F
Resistance to soldering heat	"IEC 60068-2-20", Part 2, Test Tb, method 1B, 350 °C, 3.5 s
Solderability	"IEC 60068-2-20", Part 2, Test Ta, method 1

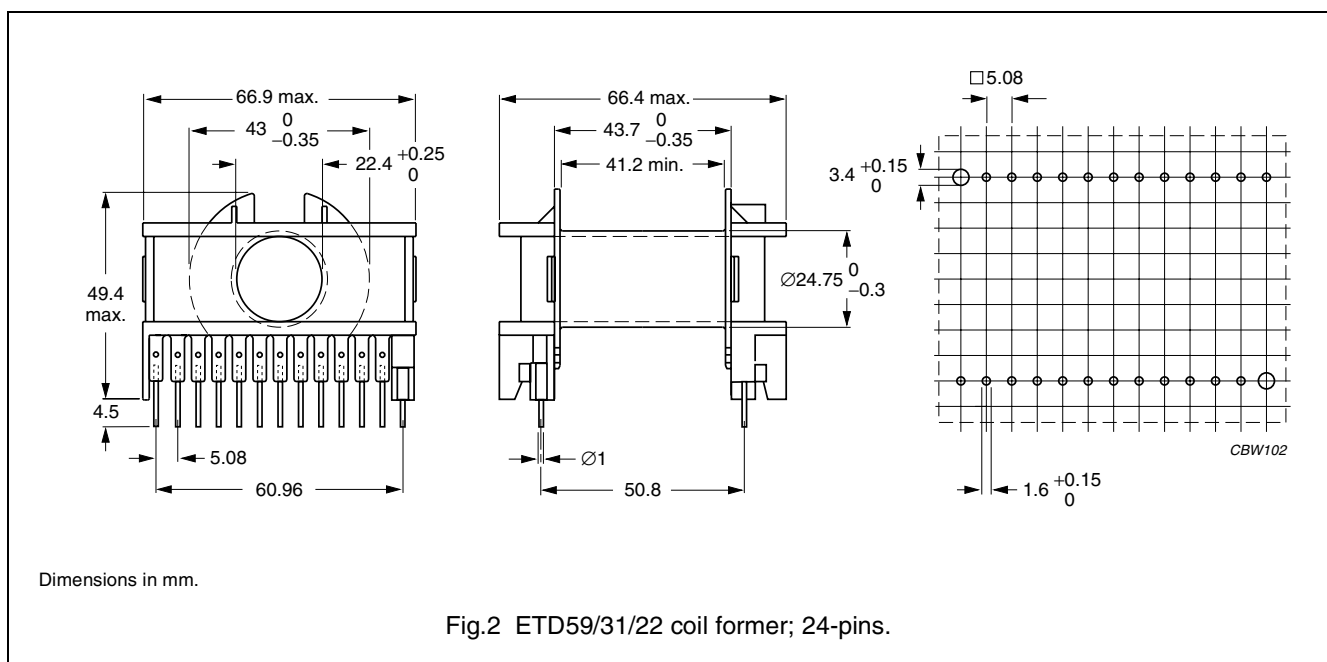

Winding data and area product for 24-pins ETD59/31/22 coil former

NUMBER OF SECTIONS	WINDING AREA (mm ²)	MINIMUM WINDING WIDTH (mm)	AVERAGE LENGTH OF TURN (mm)	AREA PRODUCT Ae x Aw (mm ⁴)	TYPE NUMBER
1	366	41.2	106	135000	CPH-ETD59-1S-24P

MOUNTING PARTS

General data

ITEM	REMARKS	FIGURE	TYPE NUMBER
Mounting clip	material: stainless steel	3	CLI-ETD59

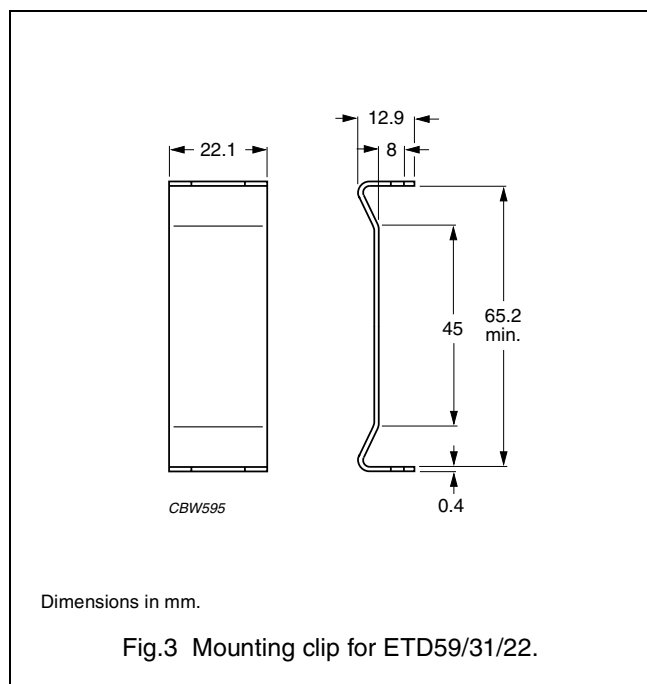

ETD cores and accessories

ETD59/31/22

DATA SHEET STATUS DEFINITIONS

DATA SHEET STATUS	PRODUCT STATUS	DEFINITIONS
Preliminary specification	Development	This data sheet contains preliminary data. Ferroxcube reserves the right to make changes at any time without notice in order to improve design and supply the best possible product.
Product specification	Production	This data sheet contains final specifications. Ferroxcube reserves the right to make changes at any time without notice in order to improve design and supply the best possible product.

DISCLAIMER

Life support applications — These products are not designed for use in life support appliances, devices, or systems where malfunction of these products can reasonably be expected to result in personal injury. Ferroxcube customers using or selling these products for use in such applications do so at their own risk and agree to fully indemnify Ferroxcube for any damages resulting from such application.

PRODUCT STATUS DEFINITIONS

STATUS	INDICATION	DEFINITION
Prototype		These are products that have been made as development samples for the purposes of technical evaluation only. The data for these types is provisional and is subject to change.
Design-in		These products are recommended for new designs.
Preferred		These products are recommended for use in current designs and are available via our sales channels.
Support		These products are not recommended for new designs and may not be available through all of our sales channels. Customers are advised to check for availability.