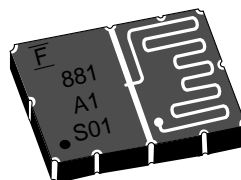

ASSP Mobile Communication Systems**SAW Duplexer (700 to 1000 MHz)****D5CB Series (D1)****DESCRIPTION**

The D5CB series of SAW antenna duplexer apply to the frequency range 700 to 1000 MHz. The SAW filters are fabricated on a lithium tantalate (LiTaO_3) substrate, producing small size and light duplexer. And its high performances is realized by using original design and patterning technology. The D1 type of SAW duplexer including transmitter filter, receiver filter and matching circuit is housed in a small package, so it is able to be stored inside thin radio card like CDPD standard.

FEATURES

- Ultra compact and light package (0.18 cc, 1.6 mm of height)
- External matching circuits are not required.
- Surface mount package (SMT)
- High handling power resistance

PACKAGE

D5CB Series (D1)

■ PIN ASSIGNMENT

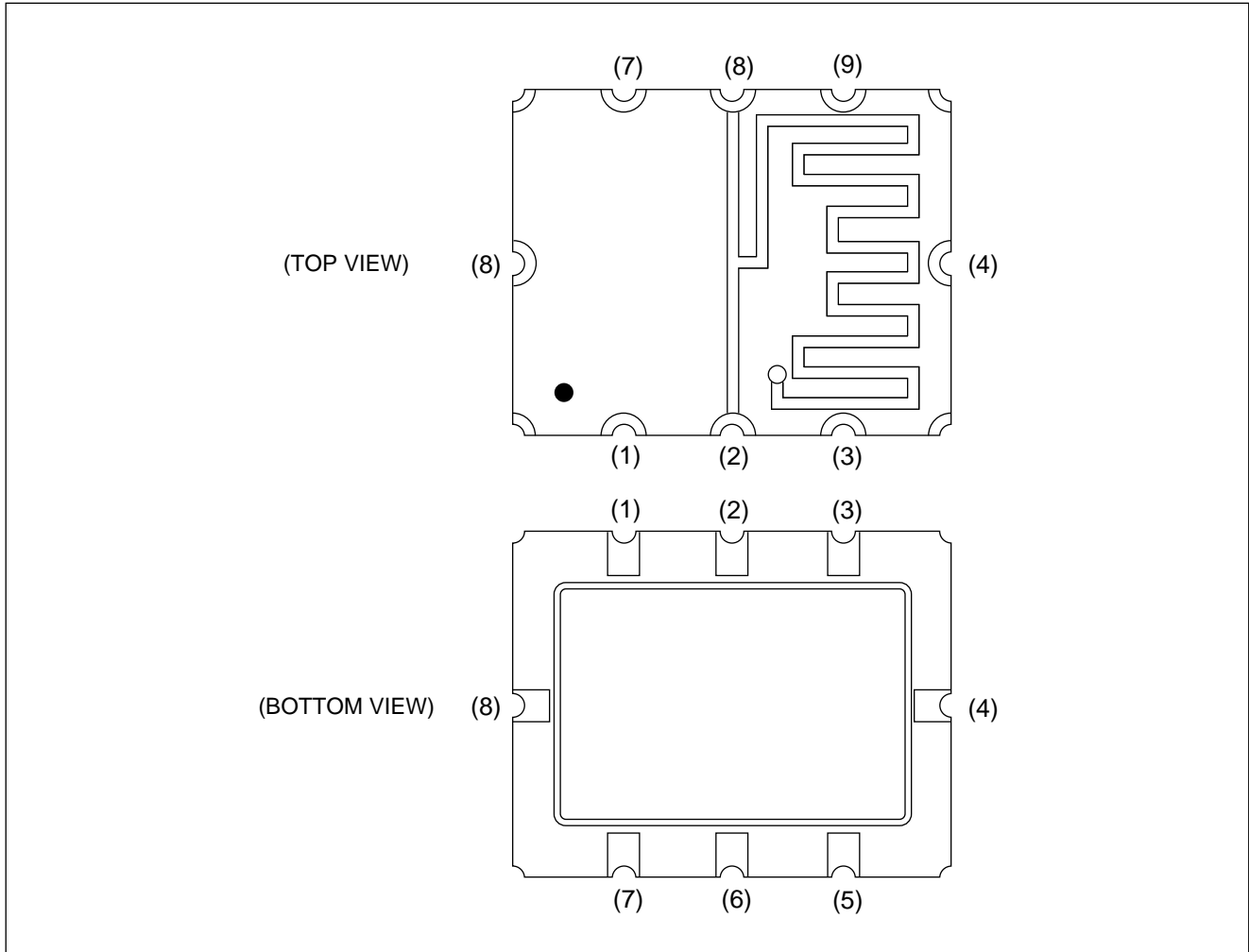

■ PIN DESCRIPTION

Pin No.	Pin name	Description
1	GND	Ground pin
2	ANT	Antenna pin *
3	GND	Ground pin
4	RX	Receiver side pin
5	GND	Ground pin
6	ANT	Antenna pin *
7	GND	Ground pin
8	TX	Transmitter side pin

* : Connect only one of two antenna pins to antenna terminal.
Regarding the other, it doesn't need to connect to any terminal.

D5CB Series (D1)

■ ABSOLUTE MAXIMUM RATINGS (See WARNING)

Parameter	Symbol	Rating	Unit
Operating temperature	T_a	-30 to +85	°C
Storage temperature	T_{stg}	-40 to +100	°C
Maximum input power	P_{IN}	1.2	W
Frequency range	—	700 to 1000	MHz

WARNING: Permanent device damage may occur if the above Absolute Maximum Ratings are exceeded. Functional operation should be restricted to the conditions as detailed in the operational sections of this data sheet. Exposure to absolute maximum rating conditions for extended periods may affect device reliability.

■ RECOMMENDED OPERATING CONDITIONS

Parameter	Symbol	Value	Unit
Operating temperature	T_a	-30 to +70	°C

■ STANDARD FREQUENCIES

System	Rx freq. (MHz)	Tx freq. (MHz)	Part number	Remarks
AMPS/ADC	824 to 849	869 to 894	FAR-D5CB-881M50-D1A1	

D5CB Series (D1)

■ ELECTRIC CHARACTERISTICS

AMPS/ADC

Part number: FAR-D5CB-881M50-D1A1

(T_a = -30 to +85°C)

Parameter	Symbol	Conditions	Value			Unit	Remarks	
			Min.	Typ.	Max.			
Tx- antenna	Insertion loss	IL	824 to 849 MHz	—	2.5	3.0	dB	
	In-band ripple	—	824 to 849 MHz	—	1.0	1.5	dB	
	Absolute attenuation	—	869 to 894 MHz	35	40	—	dB	
		—	1673 MHz	15	19	—	dB	
—	2510 MHz	10	13	—	dB			
Rx- antenna	Insertion loss	IL	869 to 894 MHz	—	3.5	4.0	dB	
	In-band ripple	—	869 to 894 MHz	—	1.5	2.5	dB	
	Absolute attenuation	—	824 to 849 MHz	40	43	—	dB	
Inband VSWR	Tx	—	824 to 849 MHz	—	1.7	2.0	—	
	Rx	—	869 to 894 MHz	—	1.7	2.0	—	
	antenna	—	824 to 849 MHz	—	1.8	2.0	—	
		—	869 to 894 MHz	—	2.0	2.5	—	

D5CB Series (D1)

TYPICAL CHARACTERISTICS

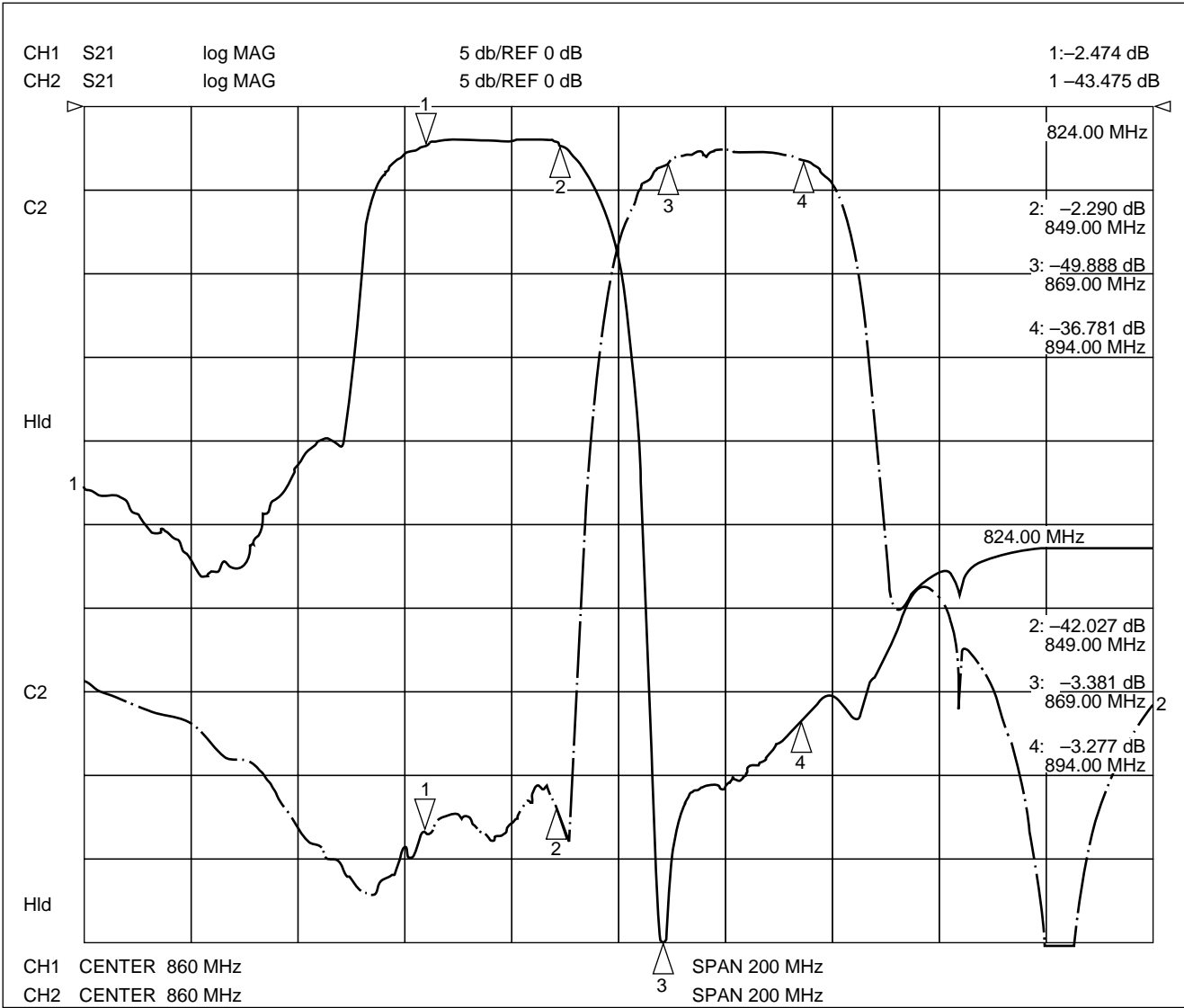

MEASUREMENT CIRCUIT

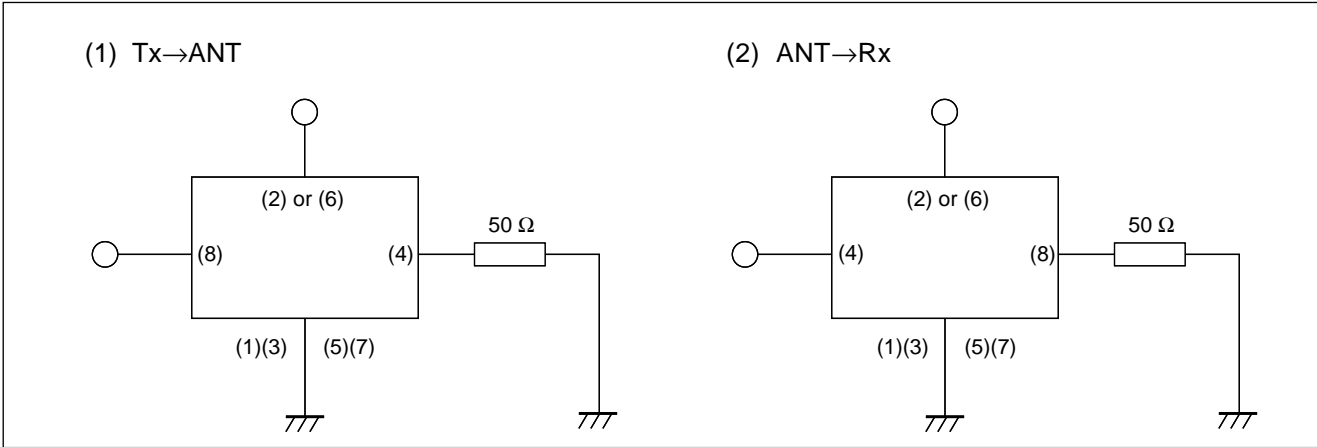

D5CB Series (D1)

■ PART NUMBER DESIGNATION

[Designation example]

FAR-D5CB-□□□□□□-D1□□-□

(1) (2) (3)

- (1) Frequency: Specify the nominal center frequency of higher frequency side in six alphanumeric. Enter M (for MHz) at the decimal point. Refer to below example.

[Example] 881.5 MHz ⇒ 881M50

- (2) Part symbol: Specified characters from A1 to Z9.

- (3) Packing: T:1 k pcs/reel

■ PACKAGE DIMENSION

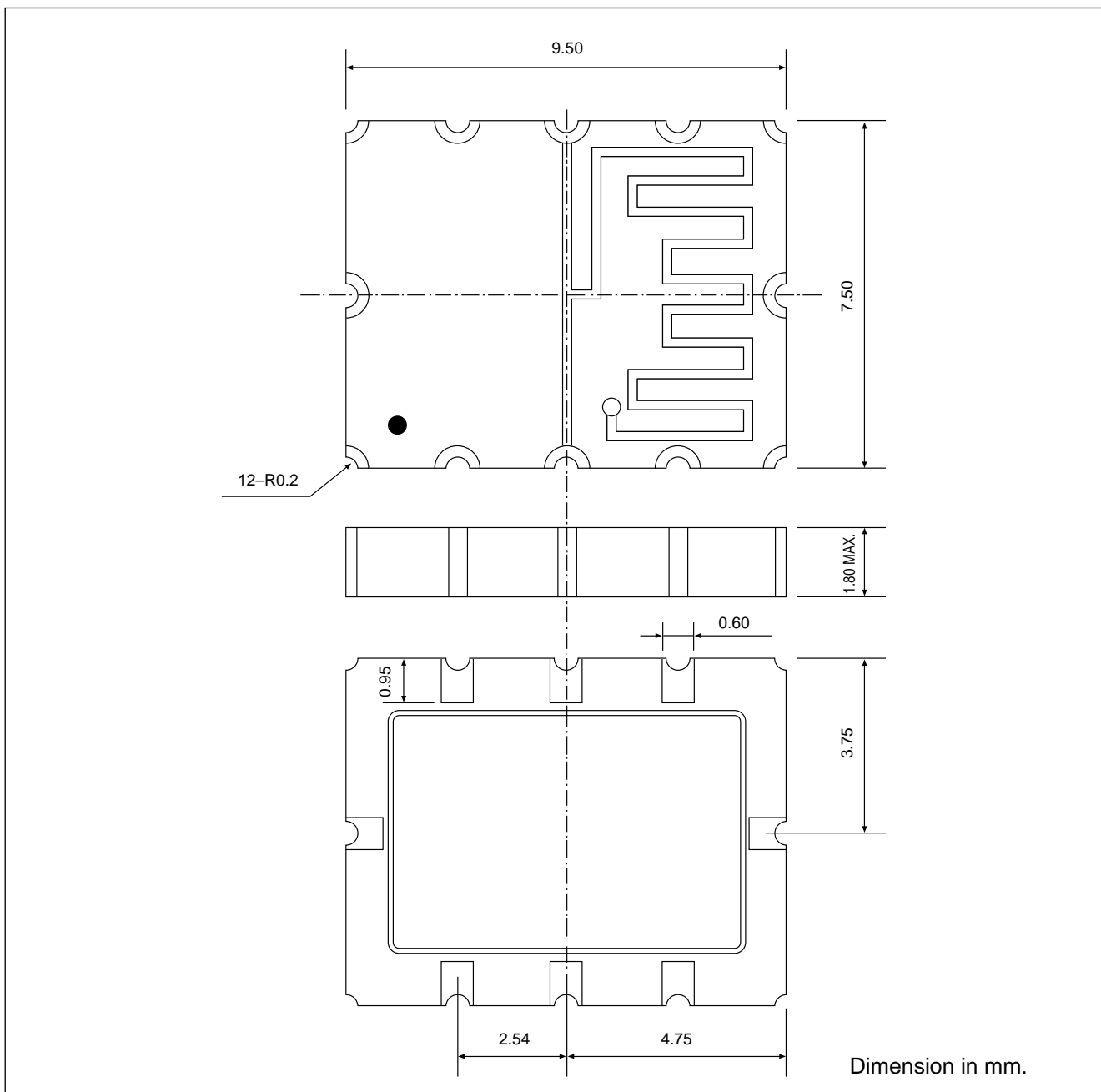

MARKING

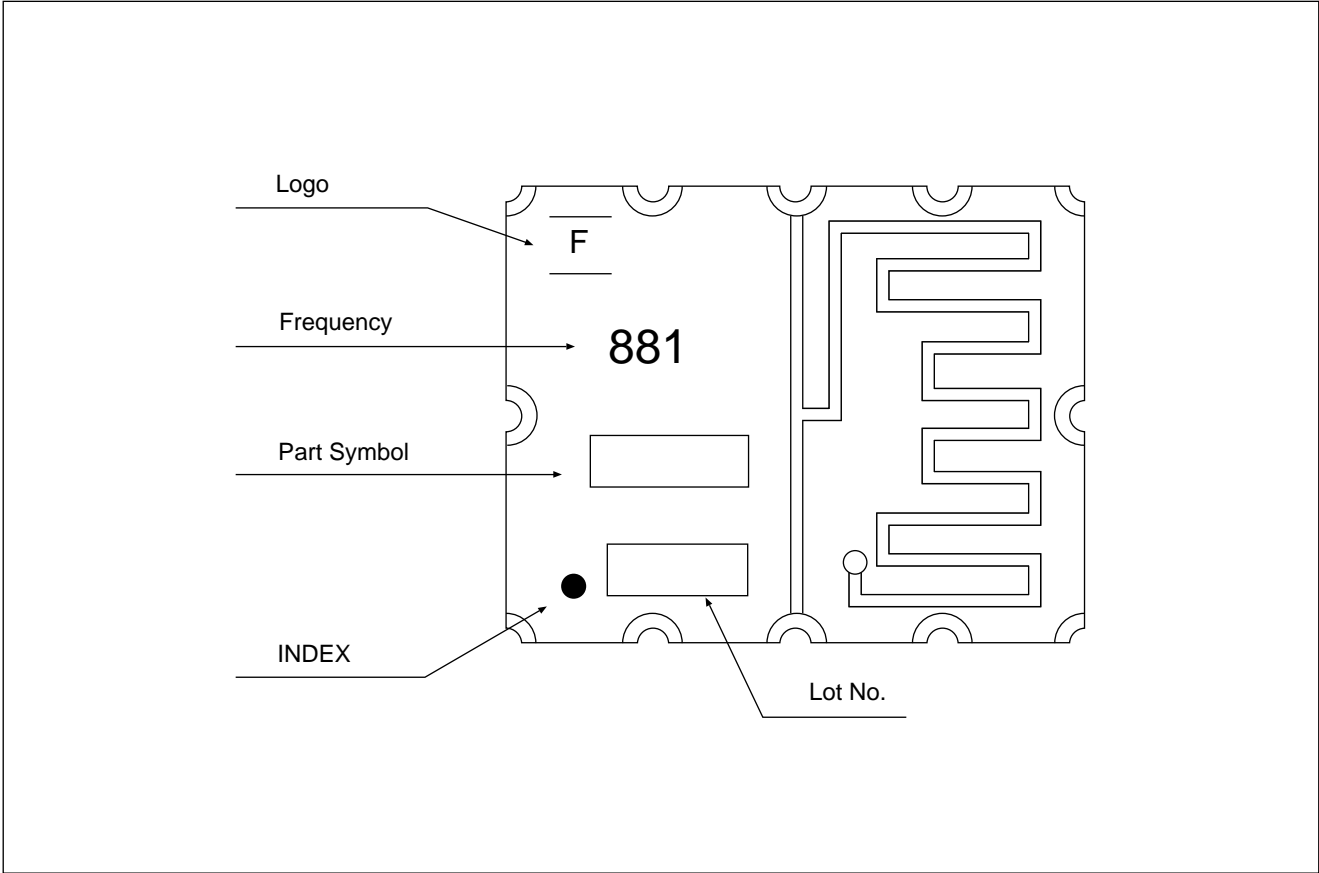

FUJITSU LIMITED

For further information please contact:

Japan

FUJITSU LIMITED
Corporate Global Business Support Division
Electronic Devices
KAWASAKI PLANT, 4-1-1, Kamikodanaka
Nakahara-ku, Kawasaki-shi
Kanagawa 211-88, Japan
Tel: (044) 754-3763
Fax: (044) 754-3329

North and South America

FUJITSU MICROELECTRONICS, INC.
Semiconductor Division
3545 North First Street
San Jose, CA 95134-1804, U.S.A.
Tel: (408) 922-9000
Fax: (408) 432-9044/9045

Europe

FUJITSU MIKROELEKTRONIK GmbH
Am Siebenstein 6-10
63303 Dreieich-Buchsschlag
Germany
Tel: (06103) 690-0
Fax: (06103) 690-122

Asia Pacific

FUJITSU MICROELECTRONICS ASIA PTE. LIMITED
#05-08, 151 Lorong Chuan
New Tech Park
Singapore 556741
Tel: (65) 281-0770
Fax: (65) 281-0220

All Rights Reserved.

The contents of this document are subject to change without notice. Customers are advised to consult with FUJITSU sales representatives before ordering.

The information and circuit diagrams in this document presented as examples of semiconductor device applications, and are not intended to be incorporated in devices for actual use. Also, FUJITSU is unable to assume responsibility for infringement of any patent rights or other rights of third parties arising from the use of this information or circuit diagrams.

FUJITSU semiconductor devices are intended for use in standard applications (computers, office automation and other office equipment, industrial, communications, and measurement equipment, personal or household devices, etc.).

CAUTION:

Customers considering the use of our products in special applications where failure or abnormal operation may directly affect human lives or cause physical injury or property damage, or where extremely high levels of reliability are demanded (such as aerospace systems, atomic energy controls, sea floor repeaters, vehicle operating controls, medical devices for life support, etc.) are requested to consult with FUJITSU sales representatives before such use. The company will not be responsible for damages arising from such use without prior approval.

Any semiconductor devices have inherently a certain rate of failure. You must protect against injury, damage or loss from such failures by incorporating safety design measures into your facility and equipment such as redundancy, fire protection, and prevention of over-current levels and other abnormal operating conditions.

If any products described in this document represent goods or technologies subject to certain restrictions on export under the Foreign Exchange and Foreign Trade Control Law of Japan, the prior authorization by Japanese government should be required for export of those products from Japan.