

## Field-programmable logic sequencer (16x48x8)

82S105 (PLS105)

## FEATURES

- Field-programmable (Ni-Cr link)
- 16 input variables
- 8 output functions
- 48 transition terms
- 6-bit State Register
- 8-bit Output Register
- Transition Complement Array
- Positive edge-trigger clock
- Programmable asynchronous preset or Output Enable
- Power-on preset to all "1" of internal registers
- $f_{MAX} = 10.5\text{MHz}$
- 650mW power dissipation (typical)
- TTL compatible
- Single +5V supply
- 3-state outputs

## APPLICATIONS

- Interface protocols
- Sequence detectors
- Peripheral controllers
- Timing generators
- Sequential circuits
- Elevator controllers
- Security locking systems
- Counters
- Shift registers

## DESCRIPTION

The 82S105 is a bipolar programmable state machine of the Mealy type. It contains logic AND-OR gate arrays with user programmable connections which control the inputs of on-chip State and Output Registers. These consist respectively of 6  $Q_P$  and 8  $Q_F$  edge-triggered, clocked S/R flip-flops, with an asynchronous Preset option. All flip-flops are unconditionally preset to "1" during power turn-on.

The AND array combines 16 external inputs,  $I_{0-15}$ , with six internal inputs,  $P_{0-5}$ , fed back from the State Register to form up to 48 transition terms (AND terms).

All transition terms can include True, False, or Don't Care states of the controlling variables, and are merged in the OR array to issue next-state and next-output commands to their respective registers on the Low-to-High transition of the Clock pulse. Both True and Complement transition terms can be generated by optional use of the internal variable (C) from the Complement Array. Also, if desired, the Preset input can be converted to Output Enable function, as an additional user-programmable option.

## ORDERING INFORMATION

DESCRIPTION	ORDER CODE	PACKAGE DESIGNATOR*
28-Pin Ceramic DIP 600mil-wide	82S105/BXA	GDIP1-T28
28-Pin Ceramic Flat Pack	82S105/BYA	GDFFP2-F28
28-Pin LLCC	82S105/B3A	CQCC2-N28

\* MIL-STD 1835 or Appendix A of 1995 Military Data Handbook

## LLCC LEAD CONFIGURATION

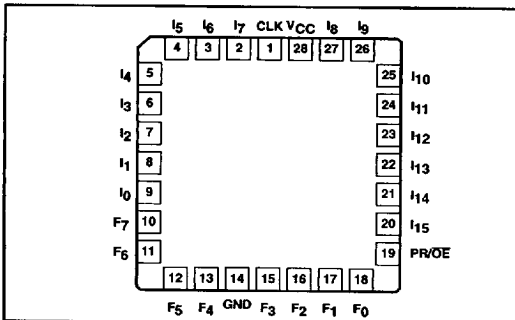

## PIN CONFIGURATION

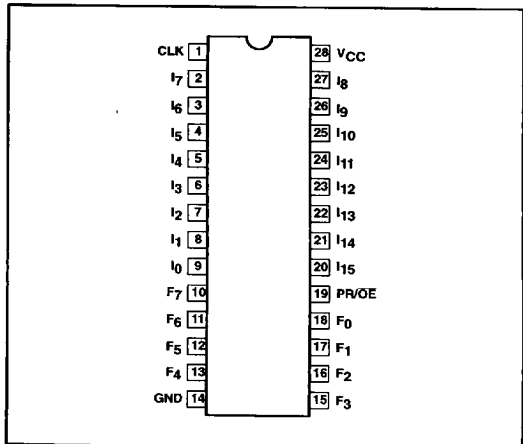

7110826 0085805 400

May 13, 1987

1017

853-0249 F08924

Field-programmable logic sequencer (16x48x8)

82S105 (PLS105)

FUNCTIONAL DIAGRAM

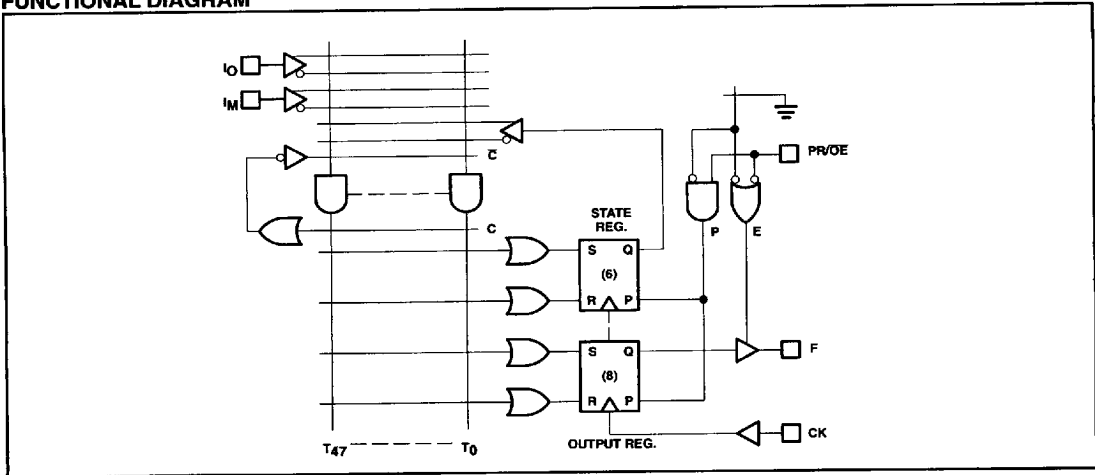

7110826 0085806 347 ■

May 13, 1987

1018

# Field-programmable logic sequencer (16x48x8)

82S105 (PLS105)

## FPLS LOGIC DIAGRAM

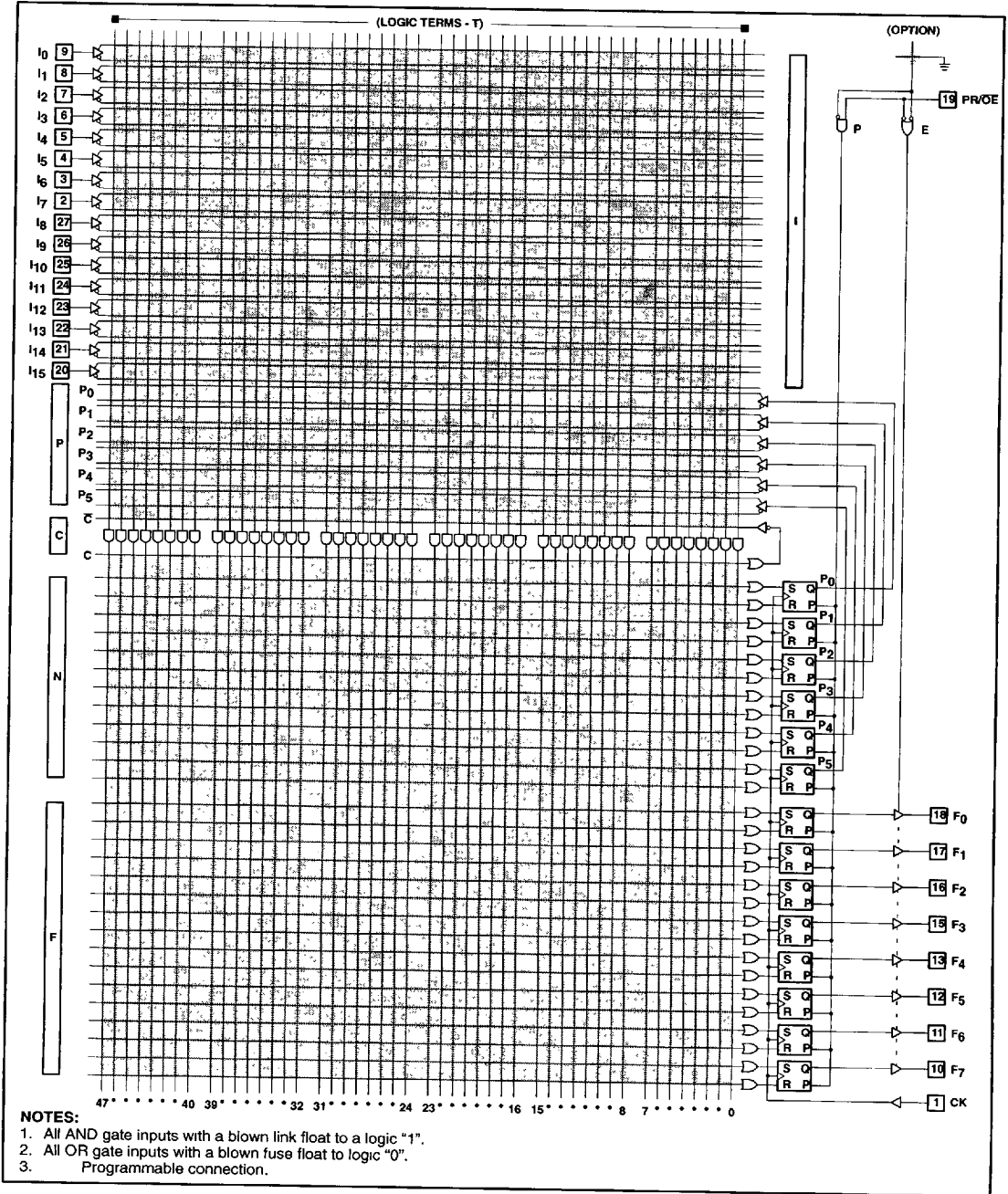

May 13, 1987

1019

7110826 0085807 283

## Field-programmable logic sequencer (16x48x8)

82S105 (PLS105)

## PIN DESCRIPTION

PIN NO.	SYMBOL	NAME AND FUNCTION	POLARITY
1	CK	<b>Clock:</b> The Clock input to the State and Output Registers. A Low-to-High transition on this line is necessary to update the contents of both registers.	Active-High
2 - 8 20 - 27	I <sub>1 - 15</sub>	<b>Logic Inputs:</b> The 15 external inputs to the AND array used to program jump conditions between machine states, as determined by a given logic sequence.	Active-High/Low
9	I <sub>0</sub>	<b>Logic/Diagnostic Input:</b> A 16th external logic input to the AND array, as above, when exercised with standard TTL levels. When I <sub>0</sub> is held at +10V, device outputs F <sub>0 - 5</sub> reflect the contents of State Register bits P <sub>0 - 5</sub> . The contents of each Output Register remains unaltered.	Active-High/Low
10 - 13 15 - 18	F <sub>0 - 7</sub>	<b>Logic/Diagnostic Outputs:</b> Eight device outputs which normally reflect the contents of Output Register bits Q <sub>0 - 7</sub> , when enabled. When I <sub>0</sub> is held at +10V, F <sub>0 - 5</sub> = (P <sub>0 - 5</sub> ), and F <sub>6, 7</sub> = Logic "1".	Active-High
19	PR/ÖE	<b>Preset or Output Enable Input:</b> A user programmable function: <ul style="list-style-type: none"> <li>• <b>Preset:</b> Provides an asynchronous preset to logic "1" of all State and Output Register bits. Preset overrides Clock, and when held High, clocking is inhibited and F<sub>0 - 7</sub> are High. Normal clocking resumes with the first full clock pulse following a High-to-Low clock transition, after Preset goes Low.</li> <li>• <b>Output Enable:</b> Provides an Output Enable function to all output buffers F<sub>0 - 7</sub> from the Output Register.</li> </ul>	Active-High (H)  Active-Low (L)

ABSOLUTE MAXIMUM RATINGS<sup>1</sup>

SYMBOL	PARAMETER	RATING		UNIT
		Min	Max	
V <sub>CC</sub>	Supply voltage		+7	V <sub>DC</sub>
V <sub>I</sub>	Input voltage		+10.0	V <sub>DC</sub>
V <sub>O</sub>	Output voltage		+5.5	V <sub>DC</sub>
I <sub>IK</sub>	Input currents	-30	+30	mA
I <sub>O</sub>	Output currents		+100	mA
T <sub>A</sub>	Operating temperature range	-55	+125	°C
T <sub>STG</sub>	Storage temperature range	-65	+150	°C

7110826 0085808 11T

May 13, 1987

1020

## Field-programmable logic sequencer (16x48x8)

82S105 (PLS105)

**DC ELECTRICAL CHARACTERISTICS**  $-55^{\circ}\text{C} \leq T_A \leq +125^{\circ}\text{C}$ ,  $4.5\text{V} \leq V_{CC} \leq 5.5\text{V}$ 

SYMBOL	PARAMETER <sup>3</sup>	TEST CONDITIONS <sup>3</sup>	LIMITS <sup>3</sup>			UNIT
			Min	Typ <sup>2</sup>	Max	
<b>Input Voltage</b>						
$V_{IH}$	High	$V_{CC} = 5.5\text{V}$	2			V
$V_{IL}$	Low	$V_{CC} = 4.5\text{V}$			0.8	V
$V_{IK}$	Clamp <sup>4</sup>	$V_{CC} = \text{Min}$ , $I_{IK} = -18\text{mA}$		-0.8	-1.2	V
<b>Output Voltage</b>						
$V_{OH}$	High <sup>5</sup>	$V_{CC} = 4.5\text{V}$ $I_{OH} = -2\text{mA}$	2.4			V
$V_{OL}$	Low <sup>6</sup>	$I_{OL} = 9.6\text{mA}$		0.35	0.5	V
<b>Input Current</b>						
$I_{IH}$	High	$V_{CC} = 5.5\text{V}$ $V_I = 5.5\text{V}$		<1	50	$\mu\text{A}$
$I_{IL}$	Low	$V_I = 0.45\text{V}$		-10	-150	$\mu\text{A}$
$I_{iL}$	Low (CK input)	$V_I = 0.45\text{V}$		-50	-350	$\mu\text{A}$
<b>Output Current</b>						
$I_{O(OFF)}$	Hi-Z state <sup>7</sup>	$V_{CC} = 5.5\text{V}$ $V_O = 5.5\text{V}$		1	60	$\mu\text{A}$
$I_{OS}$	Short circuit <sup>4, 8</sup>	$V_O = 0.45\text{V}$		-1	-60	$\mu\text{A}$
$I_{CC}$	$V_{CC}$ supply current <sup>9</sup>	$V_O = 0\text{V}$ $V_{CC} = 5.5\text{V}$	-15		-85	mA
<b>Capacitance<sup>7, 10</sup></b>						
$C_{IN}$	Input	$V_{CC} = 5.0\text{V}$ $V_I = 2.0\text{V}$		8	13	pF
$C_{OUT}$	Output	$V_O = 2.0\text{V}$		10	15	pF

7110826 0085809 056

May 13, 1987

1021

## Field-programmable logic sequencer (16x48x8)

82S105 (PLS105)

**AC ELECTRICAL CHARACTERISTICS**  $-55^{\circ}\text{C} \leq T_A \leq +125^{\circ}\text{C}$ ,  $4.5\text{V} \leq V_{\text{CC}} \leq 5.5\text{V}$ 

SYMBOL	PARAMETER	TO	FROM	LIMITS			UNIT
				Min	Typ <sup>11</sup>	Max	
<b>Pulse Width</b>							
$t_{\text{CKH}}$	Clock <sup>12</sup> High	CK-	CK+	40	15		ns
$t_{\text{CKL}}$	Clock Low	CK+	CK-	40	15		ns
$t_{\text{CKP1}}$	Period (w/o C-array)	CK+	CK+	95	40		ns
$t_{\text{CKP2}}$	Period (w/C-array) <sup>10</sup>	CK+	CK+	135	60		ns
$t_{\text{PRH}}$	Preset pulse	PR+	PR-	40	15		ns
<b>Setup Time</b>							
$t_{\text{IS1}}$	Input	CK+	Input±	60			ns
$t_{\text{IS2}}$	Input (through Complement array) <sup>13</sup>	CK+	Input±	100			ns
$t_{\text{VS}}$	Power-on preset <sup>13</sup>	CK-	V <sub>CC</sub> +	5	-10		ns
$t_{\text{PRS}}$	Preset <sup>10</sup>	CK-	PR-	5	-10		ns
<b>Hold Time</b>							
$t_{\text{IH}}$	Input <sup>10</sup>	Input±	CK+	10	-10		ns
<b>Propagation Delay</b>							
$t_{\text{CKO}}$	Clock	Output±	CK+		15	35	ns
$t_{\text{OE}}$	Output Enable <sup>13</sup>	Output-	OE-		20	40	ns
$t_{\text{OD}}$	Output Disable <sup>13</sup>	Output+	OE+		20	40	ns
$t_{\text{PR}}$	Preset	Output+	PR+		18	45	ns
$t_{\text{PPR}}$	Power-on preset <sup>10</sup>	Output+	V <sub>CC</sub> +		0	20	ns
<b>Frequency of Operation</b>							
$f_{\text{MAX}}$	w/o C-array					10.5	MHz
$f_{\text{MAX}}^{\text{C}}$	w/C-array <sup>10</sup>					8.3	MHz

**NOTES:**

- Stresses above those listed under "Absolute Maximum Ratings" may cause malfunction or permanent damage to the device. This is a stress rating only. Functional operation at these or any other conditions above those indicated in the operational and programming specification of the device is not implied.
- All typical values are at  $V_{\text{CC}} = 5\text{V}$ ,  $T_A = +25^{\circ}\text{C}$ .
- All voltage values are with respect to network ground terminal.
- Test one at a time.
- Measured with  $V_{\text{IL}}$  applied to OE and a logic High stored, or with  $V_{\text{IH}}$  applied to PR.
- Measured with a programmed logic condition for which the output is at a Low logic level, and  $V_{\text{IL}}$  applied to PR/OE Output sink current is supplied through a resistor to  $V_{\text{CC}}$ .
- Measured with  $V_{\text{IH}}$  applied to PR/OE.
- Duration of short circuit should not exceed 1 second.
- $I_{\text{CC}}$  is measured with the PR/OE input grounded, the outputs open.
- Guaranteed, but not tested.
- All typical values are at  $V_{\text{CC}} = 5\text{V}$ ,  $T_A = +25^{\circ}\text{C}$ .
- To prevent spurious clocking, clock rise time (10% - 90%)  $\leq 30\text{ns}$ .
- Not testable on unprogrammed devices.

7110826 0085810 878

May 13, 1987

1022

Field-programmable logic sequencer (16x48x8)

82S105 (PLS105)

TIMING DIAGRAMS

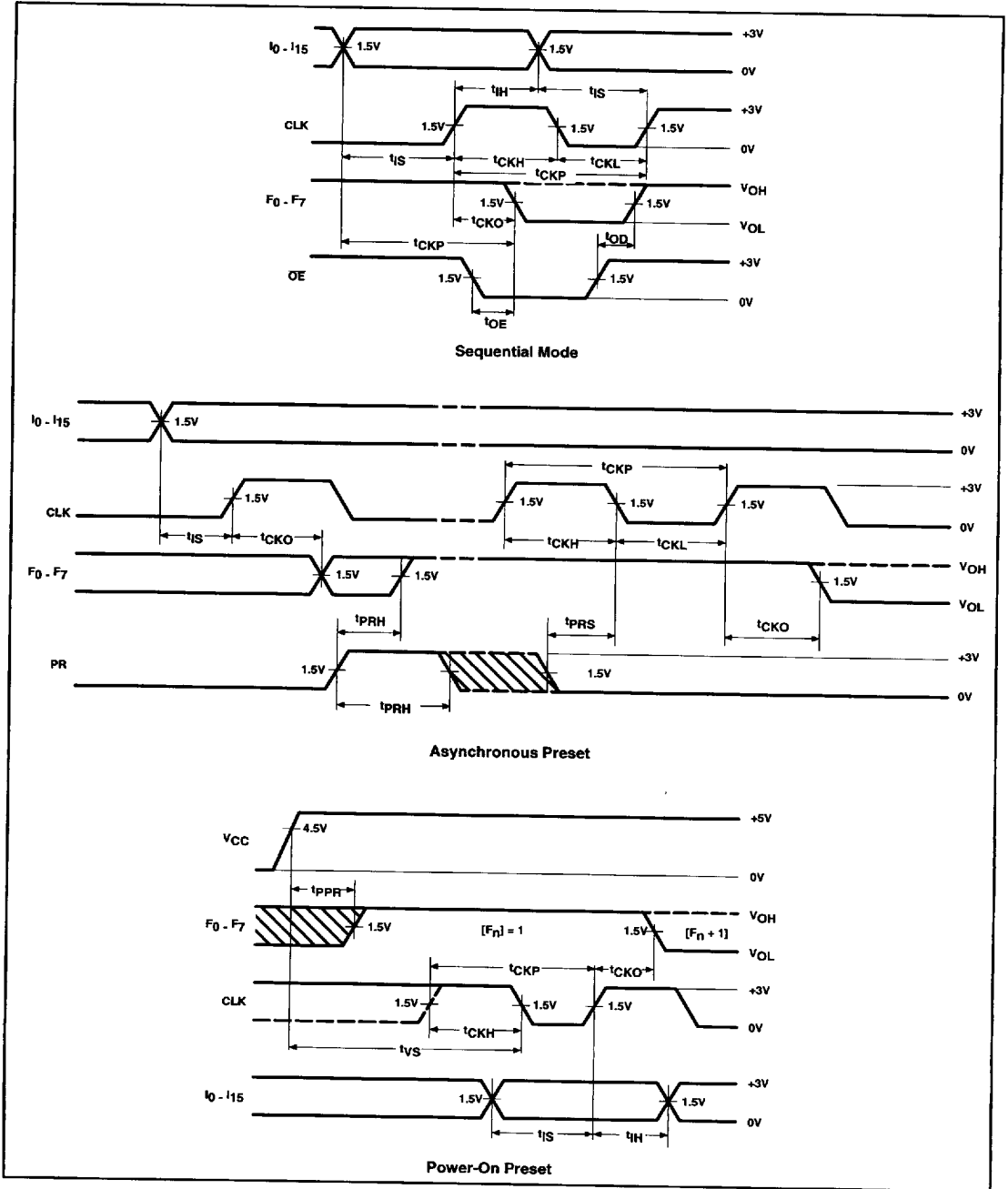

May 13, 1987

1023

7110826 0085811 704

# Field-programmable logic sequencer (16x48x8)

# 82S105 (PLS105)

## TIMING DEFINITIONS

SYMBOL	PARAMETER
t <sub>CKH</sub>	Width of input clock pulse.
t <sub>CKL</sub>	Interval between clock pulses.
t <sub>CKP1</sub>	Operating period — when not using Complement Array.
t <sub>IS1</sub>	Required delay between beginning of valid input and positive transition of Clock.
t <sub>CKP2</sub>	Operating period — when using Complement Array.
t <sub>IS2</sub>	Required delay between beginning of valid Input and positive transition of Clock, when using optional Complement Array (two passes necessary through the AND Array).
t <sub>VS</sub>	Required delay between V <sub>CC</sub> (after power-on) and negative transition of Clock preceding first reliable clock pulse.
t <sub>PRS</sub>	Required delay between negative transition of Asynchronous Preset and negative transition of Clock preceding first reliable clock pulse.
t <sub>IH</sub>	Required delay between positive transition of Clock and end of valid Input data.
t <sub>CKO</sub>	Delay between positive transition of Clock and when outputs become valid (with PR/OE Low).
t <sub>OE</sub>	Delay between beginning of Output Enable Low and when Outputs become valid.
t <sub>OD</sub>	Delay between beginning of Output Enable High and when Outputs are in the Off-State.
t <sub>PR</sub>	Delay between positive transition of Preset and when Outputs become valid at "1".
t <sub>PPR</sub>	Delay between V <sub>CC</sub> (after power-on) and when Outputs become preset at "1".

SYMBOL	PARAMETER
t <sub>PRH</sub>	Width of preset input pulse.
f <sub>MAX</sub>	Maximum clock frequency.

## LOGIC FUNCTION

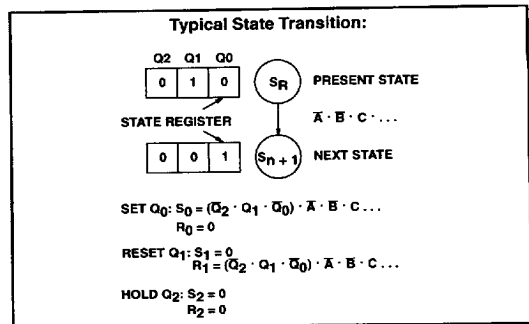

## VIRGIN STATE

A factory shipped virgin device contains all fusible links intact, such that:

1. PR/OE option is set to PR. Thus, all outputs will be at "1", as preset by initial power-up procedure.
2. All transition terms are disabled (0).
3. All S/R flip-flop inputs are disabled (0).
4. The device can be clocked via a Test Array pre-programmed with a standard test pattern.

NOTE: The Test Array pattern must be deleted before incorporating a user program. This is accomplished automatically by any Philips qualified programming equipment.

## TRUTH TABLE

V <sub>CC</sub>	OPTION		I <sub>0</sub>	CK	S	R	Q <sub>PR/F</sub>	F	
	PR	OE							
+5V	H		*	X	X	X	H	H	
	L		+10V	X	X	X	Q <sub>n</sub>	(Q <sub>P</sub> ) <sub>n</sub>	
	L		X	X	X	X	Q <sub>n</sub>	(Q <sub>F</sub> ) <sub>n</sub>	
		H	*	X	X	X	Q <sub>n</sub>	Hi-Z	
		L	+10V	X	X	X	Q <sub>n</sub>	(Q <sub>P</sub> ) <sub>n</sub>	
		L	X	X	X	X	Q <sub>n</sub>	(Q <sub>F</sub> ) <sub>n</sub>	
		L	X	↑	L	L	Q <sub>n</sub>	(Q <sub>F</sub> ) <sub>n</sub>	
		L	X	↑	L	H	L	L	
		L	X	↑	H	L	H	H	
		L	X	↑	H	H	IND.	IND.	
		L	X	X	X	X	X	H	
	↑	X	X	X	X	X	X	H	

### NOTES:

1. Positive Logic  $S/R = T_0 + T_1 + T_2 + T_4$   
 $T_n = C(I_0 I_1 I_2) (P_0 P_1 P_5)$
2. Either Preset (Active-High) or Output Enable (active-Low) are available, but not both. The desired function is a user programmable option.
3. ↑ denotes transition from Low to High level.
4. R = S = High is an illegal input condition.
5. \* = H/L/+10V
6. X = Don't Care ( $\leq 5.5V$ )



# Field-programmable logic sequencer (16x48x8)

82S105 (PLS105)

## TEST LOAD CIRCUITS

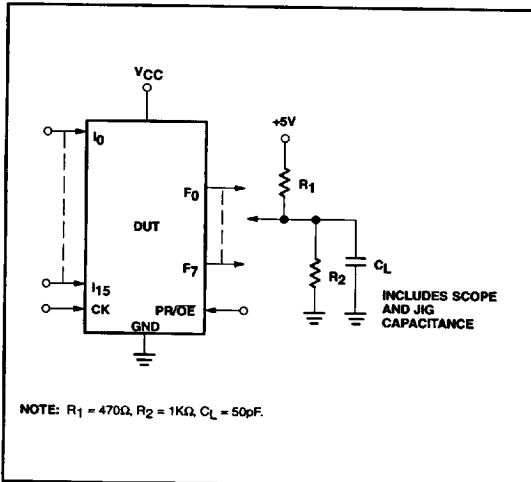

## VOLTAGE WAVEFORMS

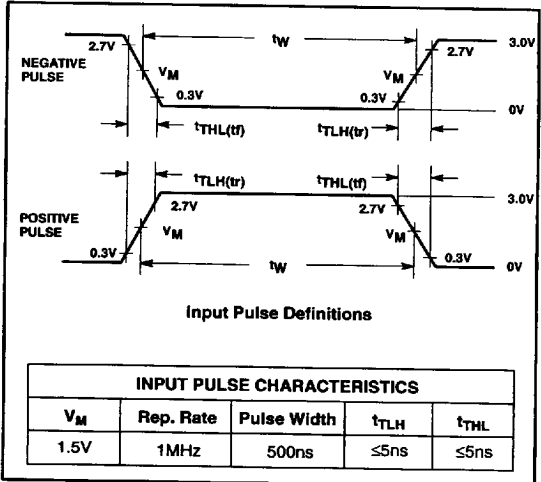

## LOGIC PROGRAMMING

The FPLS can be programmed by means of Logic programming equipment.

With Logic programming, the AND/OR gate input connections necessary to implement the desired logic function are coded directly

from the State Diagram using the Program Table on the following page.

In this table, the logic state or action of control variables C, I, P, N and F, associated with each Transition Term  $T_n$  is assigned a symbol which results in the proper fusing pattern of corresponding link pairs, defined as follows:

## PRESET/OE OPTION - (P/E)

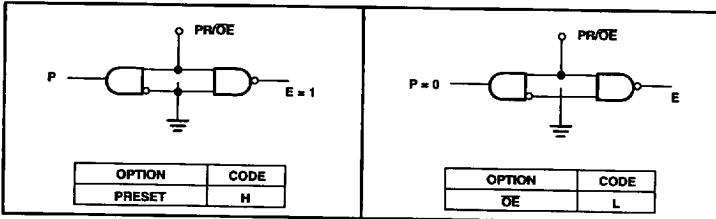

## PROGRAMMING THE 82S105:

The 82S105 has a power-up preset feature. This feature insures that the device will power-up in a known state with all register elements (State and Output Register) at logic High (H). When programming the device it is important to realize this is the initial state of the device. You *must* provide a next state jump if you do not wish to use all Highs (H) as the present state.

## "AND" ARRAY - (I), (P)

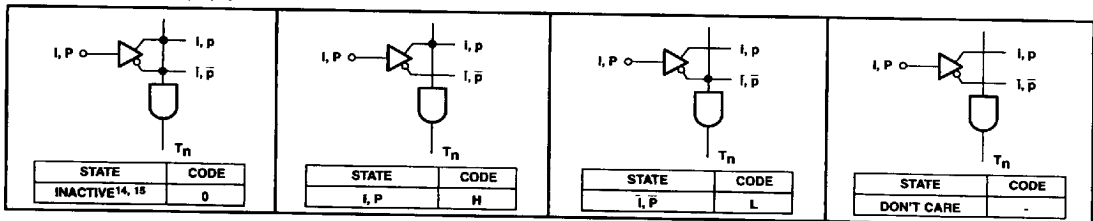

Field-programmable logic sequencer (16x48x8)

82S105 (PLS105)

“OR” ARRAY - (N), (F)

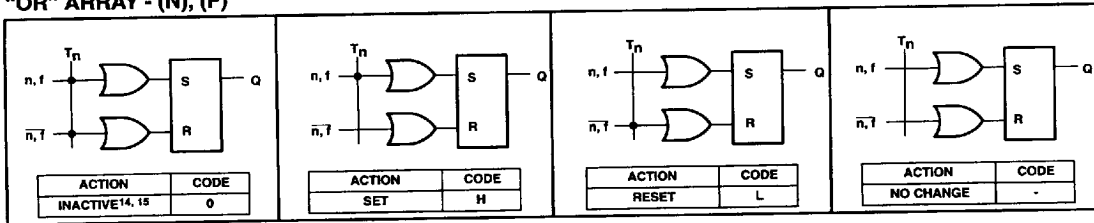

“COMPLEMENT” ARRAY - (C)

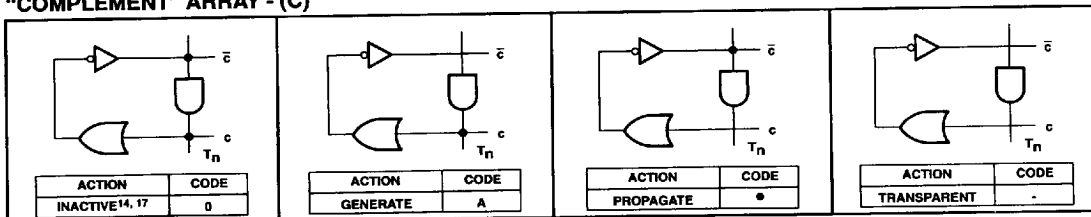

NOTES:

- 14. This is the initial unprogrammed state of all link pairs. It is normally associated with all unused (inactive) AND gates  $T_n$ .
- 15. Any gate  $T_n$  will be unconditionally inhibited if any one of its I or P link pairs are left intact.
- 16. To prevent simultaneous Set and Reset flip-flop commands, this state is not allowed for N and F link pairs coupled to active gates  $T_n$  (see flip-flop truth tables).
- 17. To prevent oscillations, this state is not allowed for C link pairs coupled to active gates  $T_n$ .

7110826 0085814 413 ■

May 13, 1987

1026



