

Si PIN photodiode

S2721-02, S3096-02, S4204, S8703

Dual-element, plastic package photodiode

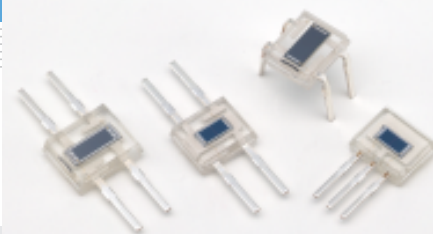

S2721-02, S3096-02, S4204 and S8703 are dual-element Si PIN photodiodes molded into small plastic packages. Having high sensitivity and low noise, these photodiodes have very low cross-talk between the elements.

Custom devices (with different element shapes, number of elements, characteristics and packages) are also available to meet your specific needs. Please feel free to contact our sales office.

Features

- High sensitivity
- Uniform element sensitivity
- Low cross-talk
- Low noise

Applications

- CD, DVD, MO (Magneto-Optical disc) signal pickups
- Laser beam alignment
- Various position detection applications

General ratings / Absolute maximum ratings

| Type No. | Dimensional outline | Active area (mm) | Element gap (μm) | Absolute maximum ratings | | |
|----------|---------------------|----------------------|----------------------------------|--------------------------------------|---|---|
| | | | | Reverse voltage V_R Max. (V) | Operating temperature T_{opr} ($^{\circ}\text{C}$) | Storage temperature T_{stg} ($^{\circ}\text{C}$) |
| S2721-02 | ① | 1 × 3 / 2 elements | 5 | 20 | -25 to +85 | -40 to +100 |
| S3096-02 | ② | 1.2 × 3 / 2 elements | 30 | | | |
| S4204 | ③ | 1 × 2 / 2 elements | 20 | | | |
| S8703 | ④ | | | | | |

Electrical and optical characteristics (Typ. $T_a=25^{\circ}\text{C}$, unless otherwise noted, per 1 element)

| Type No. | Spectral response range λ (nm) | Peak sensitivity wavelength λ_p (nm) | Photo sensitivity $\lambda=\lambda_p$ (A/W) | Dark current I_D $V_R=10\text{ V}$ all elements | | Temp. coefficient of I_D T_{CID} (times/ $^{\circ}\text{C}$) | Cut-off frequency f_c $V_R=10\text{ V}$ $R_L=50\ \Omega$ $\lambda=780\text{ nm}$ -3 dB (MHz) | Terminal capacitance C_t $V_R=10\text{ V}$ $f=1\text{ MHz}$ (pF) | NEP $V_R=10\text{ V}$ ($\text{W}/\text{Hz}^{1/2}$) |
|----------|--|--|---|--|-----------|---|--|--|--|
| | | | | Typ. (nA) | Max. (nA) | | | | |
| S2721-02 | 320 to 1060 | 900 | 0.56 | 0.1 | 2.0 | 1.15 | 50 | 5 | 6.4×10^{-15} |
| S3096-02 | | | 0.58 | 0.05 | 0.5 | | 25 | | 7.2×10^{-15} |
| S4204 | | 960 | 0.65 | 0.1 | 1.0 | | 30 | 3 | 8.7×10^{-15} |
| S8703 | | | | | | | | | |

Si PIN photodiode S2721-02, S3096-02, S4204, S8703

■ Spectral response

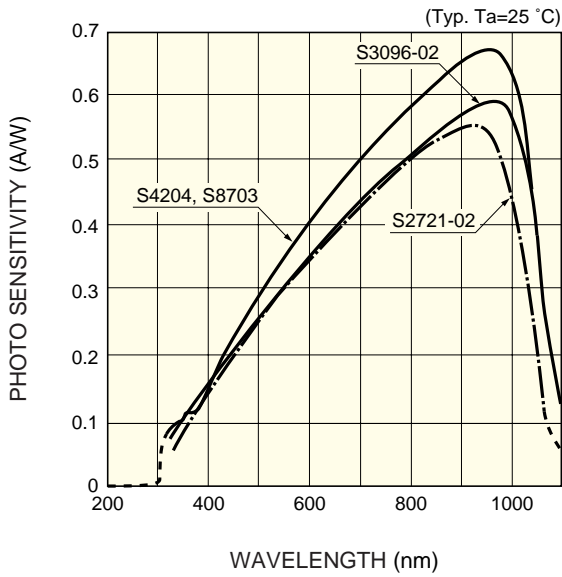

KMPDB0134EB

■ Photo sensitivity temperature characteristics

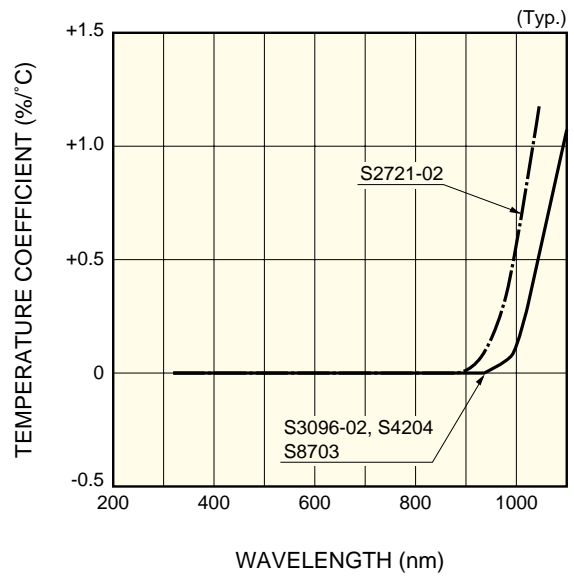

KMPDB0135EC

■ Dark current vs. reverse voltage

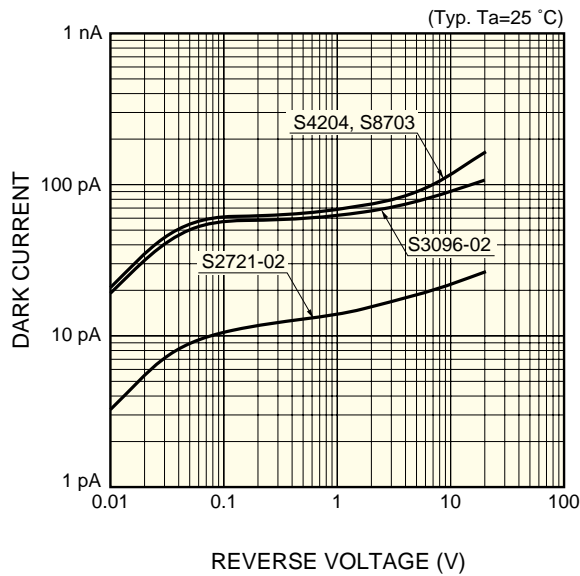

KMPDB0136EB

■ Terminal capacitance vs. reverse voltage

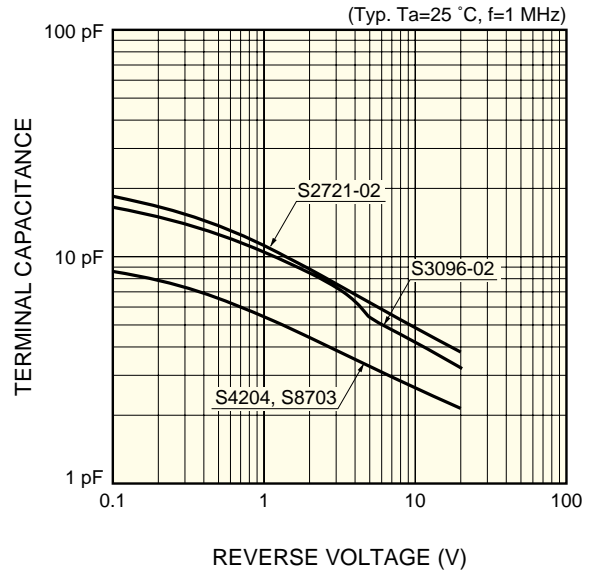

KMPDB0137EB

Si PIN photodiode S2721-02, S3096-02, S4204, S8703

■ Dimensional outlines (unit: mm, tolerance unless otherwise noted: ± 0.1)

① S2721-02

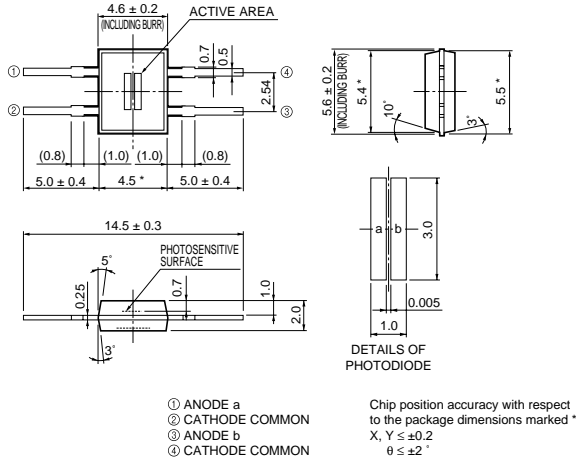

KMPDA0118EA

② S3096-02

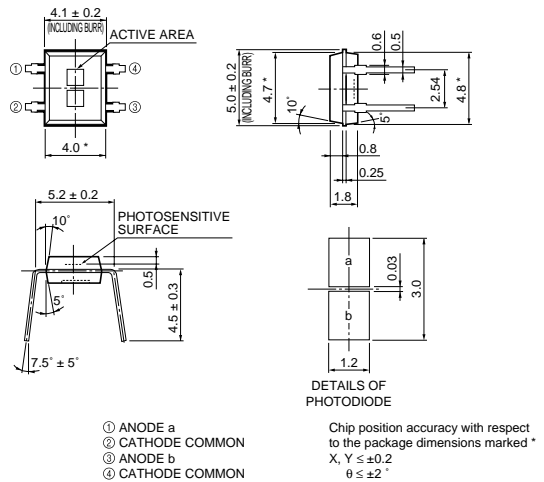

KMPDA0119EA

③ S4204

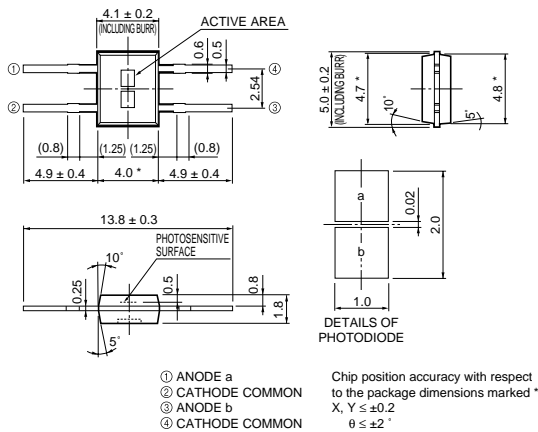

KMPDA0120EA

④ S8703

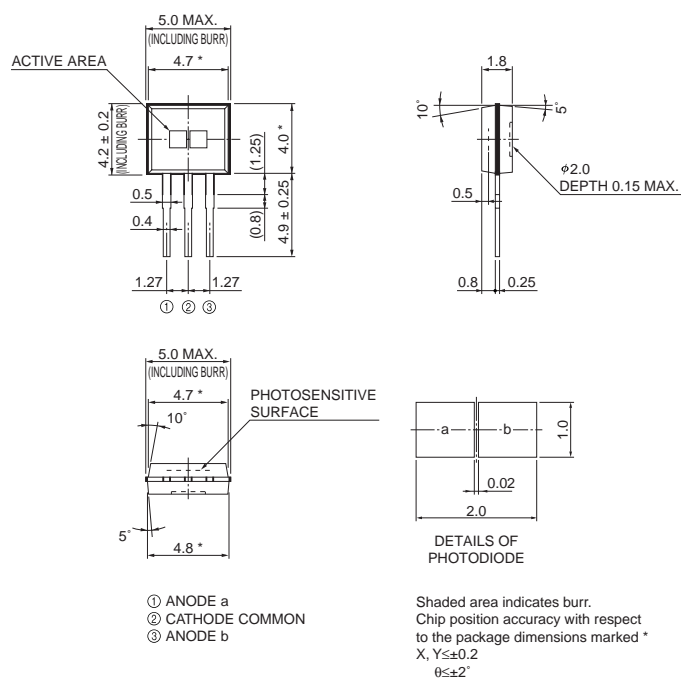

KMPDA0181EA

HAMAMATSU

Information furnished by HAMAMATSU is believed to be reliable. However, no responsibility is assumed for possible inaccuracies or omissions. Specifications are subject to change without notice. No patent rights are granted to any of the circuits described herein. ©2003 Hamamatsu Photonics K.K.

HAMAMATSU PHOTONICS K.K., Solid State Division

1126-1 Ichino-cho, Higashi-ku, Hamamatsu City, 435-8558 Japan, Telephone: (81) 53-434-3311, Fax: (81) 53-434-5184, <http://www.hamamatsu.com>

U.S.A.: Hamamatsu Corporation: 360 Foothill Road, P.O.Box 6910, Bridgewater, N.J. 08807-0910, U.S.A., Telephone: (1) 908-231-0960, Fax: (1) 908-231-1218

Germany: Hamamatsu Photonics Deutschland GmbH: Arzbergerstr. 10, D-82211 Herrsching am Ammersee, Germany, Telephone: (49) 08152-3750, Fax: (49) 08152-2658

France: Hamamatsu Photonics France S.A.R.L.: 19, Rue du Saule Trapu, Parc du Moulin de Massy, 91882 Massy Cedex, France, Telephone: 33-(1) 69 53 71 10, Fax: 33-(1) 69 53 71 10

United Kingdom: Hamamatsu Photonics UK Limited: 2 Howard Court, 10 Tewin Road, Welwyn Garden City, Hertfordshire AL7 1BW, United Kingdom, Telephone: (44) 1707-294888, Fax: (44) 1707-325777

North Europe: Hamamatsu Photonics Norden AB: Smidesvägen 12, SE-171 41 Solna, Sweden, Telephone: (46) 8-509-031-00, Fax: (46) 8-509-031-01

Italy: Hamamatsu Photonics Italia S.R.L.: Strada della Moia, 1/E, 20020 Arese, (Milano), Italy, Telephone: (39) 02-935-81-733, Fax: (39) 02-935-81-741

Cat. No. KMPD1039E03
Dec. 2003 DN