

Description

The GM393 consist of two independent precision voltage comparators with an offset voltage specification as low as 2.0 mV, max for two comparators which were designed specifically to operate from a single power supply over a wide range of voltages. Operation from split power supplies is also possible and the low power supply current drain is independent of the magnitude of the power supply voltage. These comparators also have a unique characteristic. In that, the input common-mode voltage range includes ground, even though operated from a single power supply voltage.

Application areas include limit comparators, simple analog to digital converters; pulse, square wave and time delay generators; wide range VCO; MOS clock timers; multivibrators and high voltage digital logic gates. The GM393 are designed to directly interface with TTL and CMOS. When operated from both plus and minus power supplies, the GM393 will directly interface with MOS logic, where their low power drain is a distinct advantage over standard comparators.

The GM393 is available in DIP-8 and SOP-8 packages.

Features

- ◆ Single- supply Range: $\pm 1.0V$ to $\pm 18V$
- ◆ Wide supply voltage range: $\pm 2.0V$ to $\pm 36V$
- ◆ Very low supply current drain (0.4 mA) -
- ◆ independent of supply voltage
- ◆ Low input biasing current: 25 nA
- ◆ Low input offset current: ± 5 nA
- ◆ Maximum offset voltage: ± 3 mV
- ◆ Input common-mode voltage range includes ground
- ◆ Differential input voltage range equal to the power supply voltage
- ◆ Low output saturation voltage: 250 mV at 4 mA
- ◆ Output voltage compatible with TTL, DTL, ECL, MOS and CMOS logic systems

Application

High precision comparators

Reduced V_{OS} drift over temperature

Eliminates need for dual supplies

Allows sensing near GND

Compatible with all forms of logic

Power drain suitable for battery operation

CONNECTION DIAGRAM

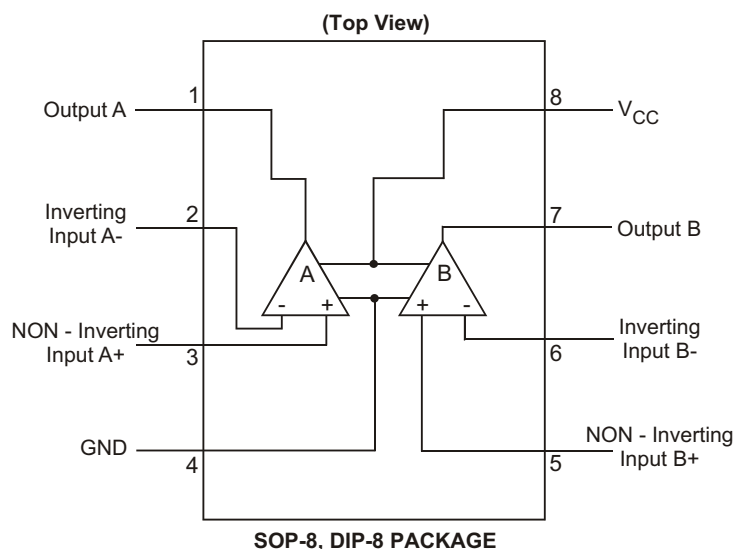

◆ MARKING INFORMATION & PIN CONFIGURATIONS

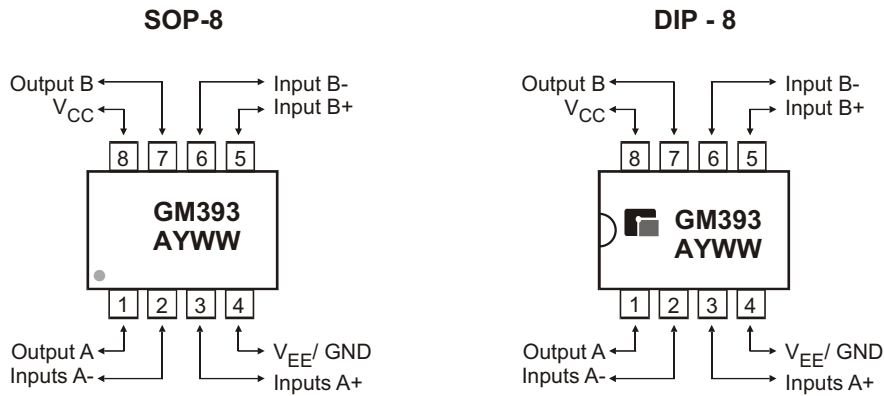

A : Assembly Location
Y : Year
W W : Weekly

◆ ORDERING INFORMATION

Ordering Number	Package	Shipping
GM393D8T	DIP-8	60 Units / Tube
GM393S8T	SOP-8	100 Units / Tube
GM393S8R	SOP-8	2,500 Units/Tape & Reel

* For detail Ordering Number identification, please see last page.

◆ ABSOLUTE MAXIMUM RATINGS

PARAMETER	SYMBOL	VALUE	UNIT
Power Dissipation	P_D	780	mW
DIP package SOP package		510	
Supply Voltage	V_{CC}	$\pm 36, \pm 18$	V
Input Current	I_O	50	mA
Operating Temperature Range	T_J	0 to +70	$^{\circ}\text{C}$
Lead Temperature (Soldering, 10 sce)	T_{LEAD}	260	$^{\circ}\text{C}$
Storage Temperature Range	T_{STG}	-65 to +150	$^{\circ}\text{C}$

◆ SCHEMATIC BLOCK DIAGRAM

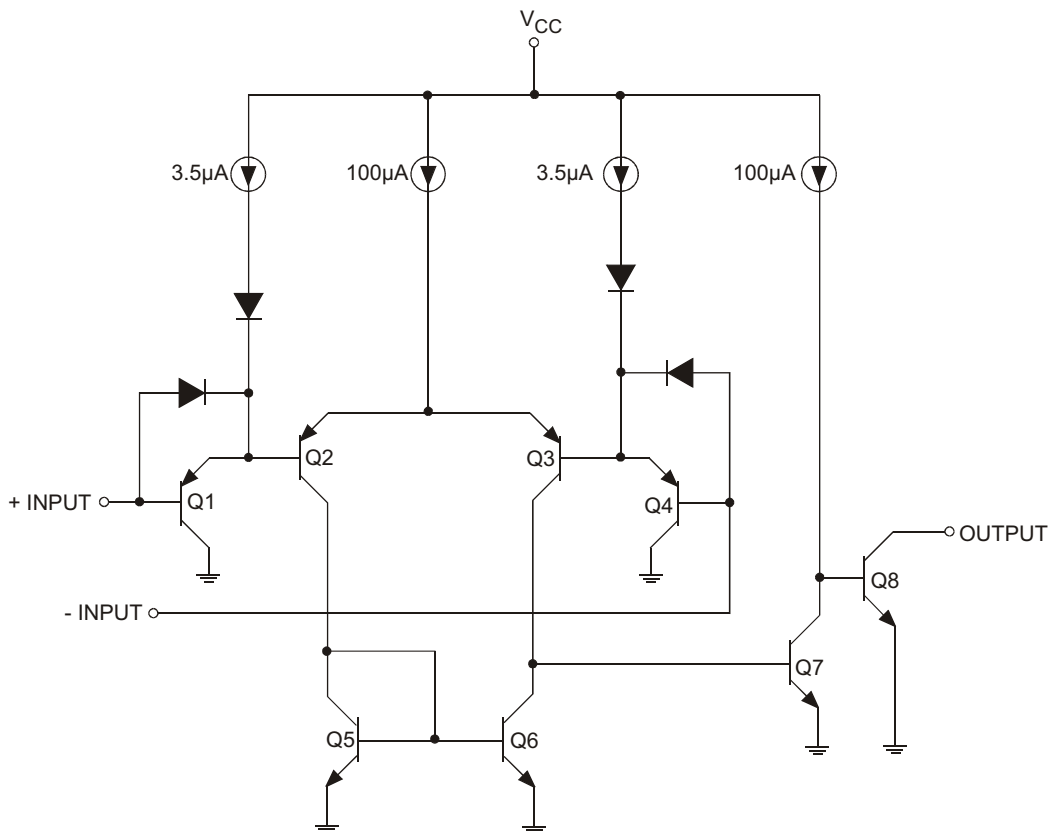

◆ ELECTRICAL CHARACTERISTICS

($V_{CC} = 5V$, at specified free - air temperature, unless otherwise specified)

CHARACTERISTICS	SYMBOL	TEST CONDITIONS	MIN	TYP	MAX	UNIT	
Input Offset Voltage	V_{IO}	$V_{CC} = 5V \text{ to } 30V$, $V_{CC} = V_{ICRmin}$, $V_O = 1.4V$	25°C		±2	±5	mV
			Full range			9	
Input Offset Current	I_{IO}	$V_O = 1.4V$	25°C		±5	±50	nA
			Full range			±150	
Input Bias Current	I_{IB}	$V_O = 1.4V$	25°C		-25	-250	nA
			Full range			400	
Common - Mode Input Voltage Range **	V_{ICR}		25°C	0 to $V_{CC} - 1.5$			V
			Full range	0 to $V_{CC} - 2$			
Low - Level Output Voltage	V_{OL}	$I_{OL} = 4mA$, $V_{ID} = -1V$	25°C		150	400	mV
			Full range			700	
Large - Signal Differential Voltage Amplification	A_{VD}	$V_{CC} = 15V$, $V_O = 14V$ to 11.4V, $R_L > 15k \text{ to } V_{CC}$	25°C	50	200		V/ mV
High - Level Output Current	I_{OH}	$V_{OH} = 5V$, $V_{ID} = 1V$	25°C		0.1	50	nA
		$V_{OH} = 30V$, $V_{ID} = 1V$	Full range			1	
Low - Level Output Current	I_{OL}	$V_{OL} = 1.5V$, $V_{ID} = -1V$	25°C	6			mA
Supply Current	I_{CC}	$R_L = \infty$, $V_{CC} = 5V$	25°C		0.8	1.0	mA
		$R_L = \infty$, $V_{CC} = 30V$	Full range			2.5	

* All characteristics are measured under open loop conditions with zero common - mode input voltage unless otherwise specified. Full range is 0°C to 70°C.

** The voltage at either input or common - mode should not be allowed to go negative by more than 0.3V.

The upper end of the common - mode voltage range is $V_{CC} - 1.5V$, but either or both inputs can go to 30V without damage.

◆ SWITCHING CHARACTERISTICS, $V_{CC} = 5V$, $T_A = 25^\circ C$

PARAMETER	TEST CONDITIONS	MIN	TYP	MAX	UNIT
Response time	R_L Connected to 5V through 5.1k , $C_L = 15pF^*$ (See Note 1)	100 - mV input step with 5 - mV overdrive		1.3	μs
		TTL - level input step		0.3	

* C_L includes probe and jig capacitance.

Note 1: The response time specified is the interval between the input step function and the instant when the output crosses 1.4V.

◆ Typical Performance Characteristics

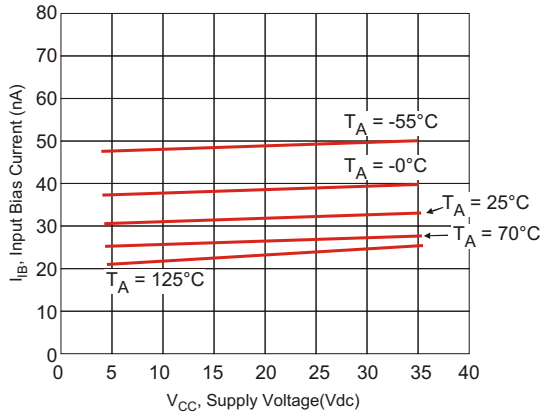

Figure 1. Input Bias Current versus Power Supply Voltage

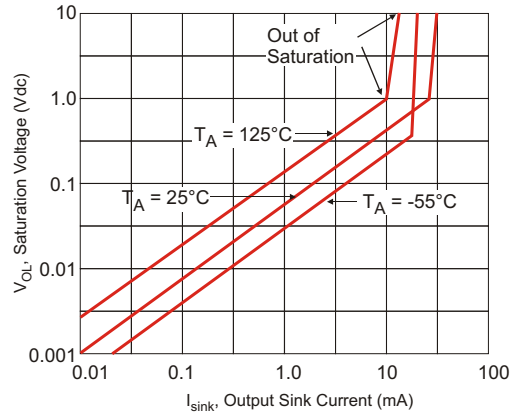

Figure 2. Output Saturation Voltage versus Output Sink Current

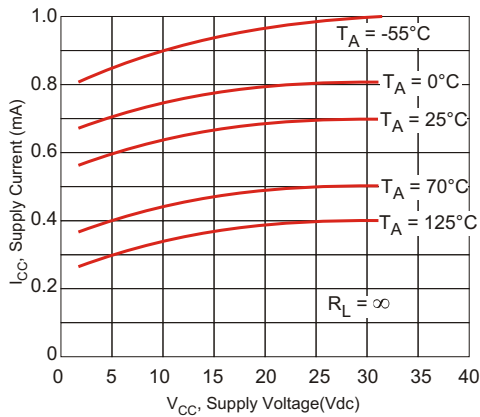
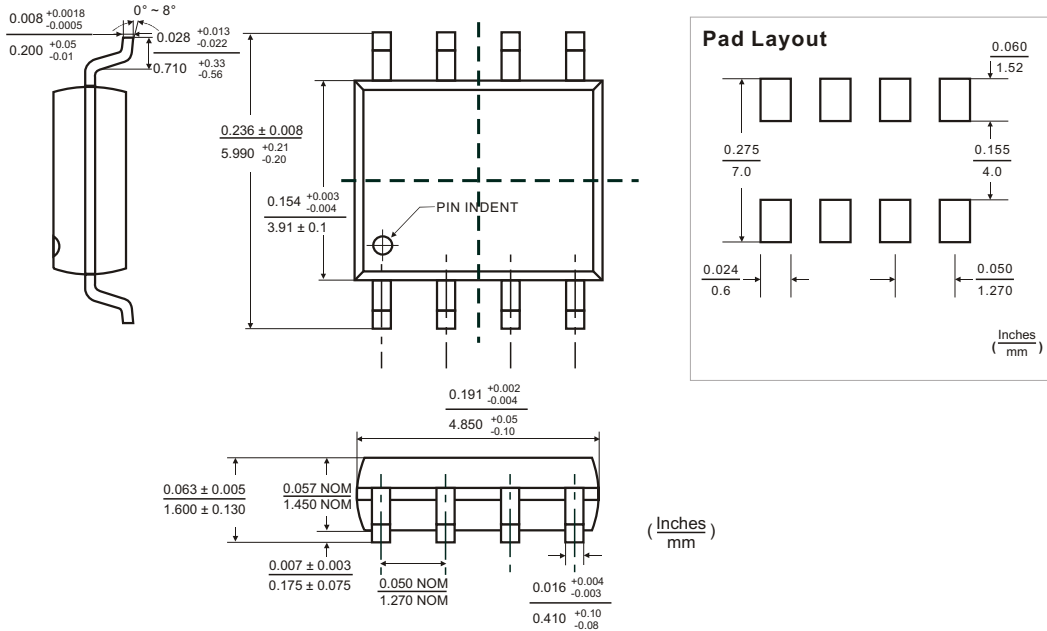
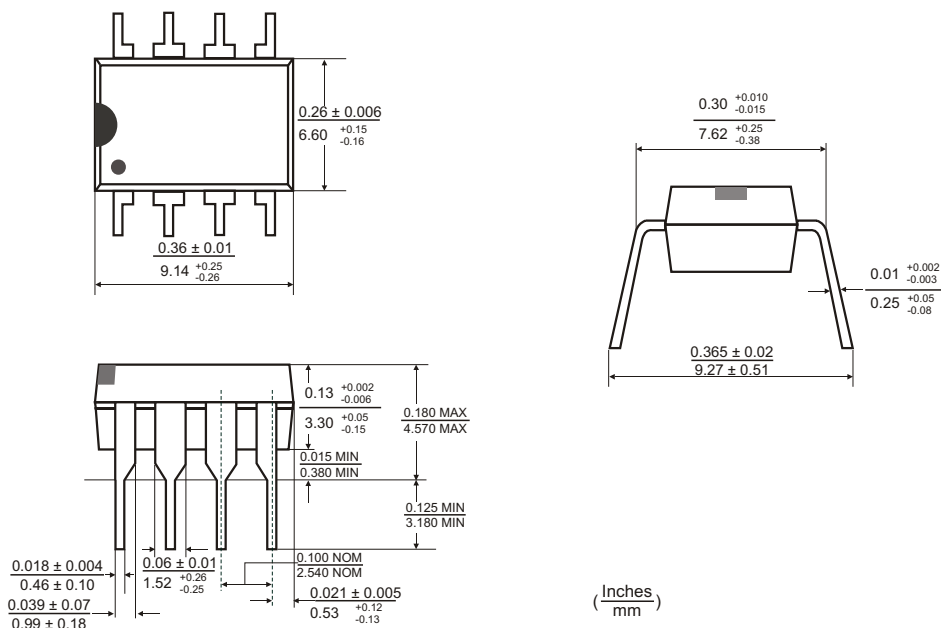

Figure 3. Power Supply Current versus Power Supply Voltage

◆ SOP-8 PACKAGE OUTLINE DIMENSIONS





◆ DIP-8 PACKAGE OUTLINE DIMENSIONS

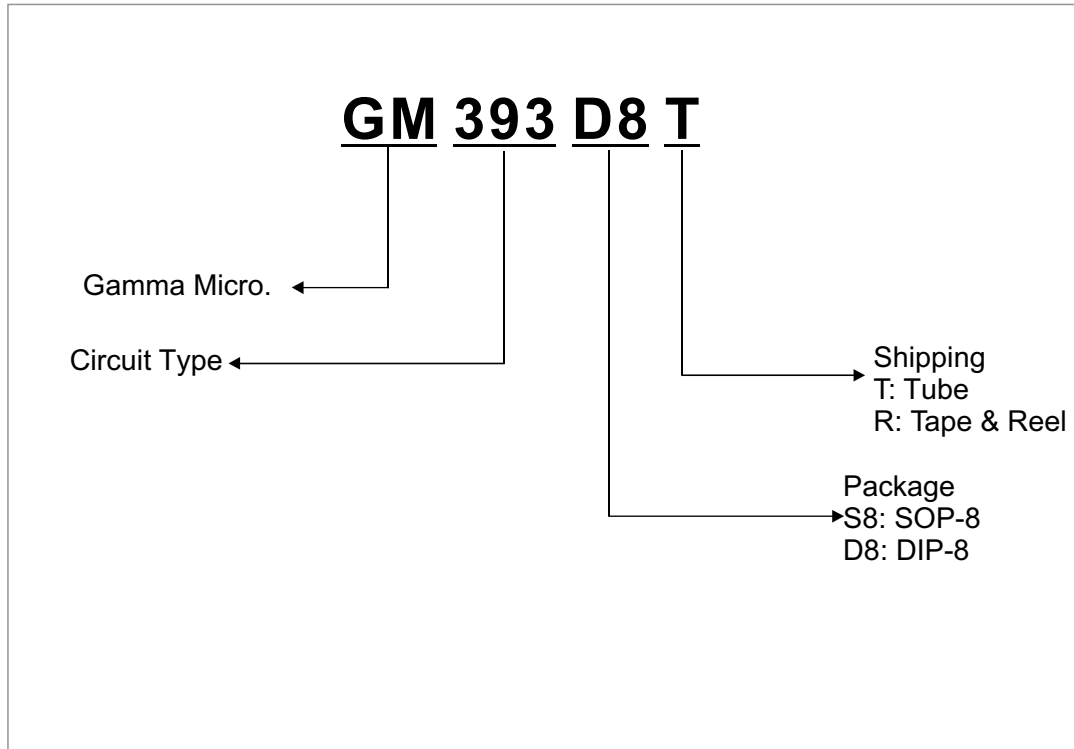

◆ ORDERING NUMBER



GAMMA Micro, , and  are registered trademarks of GAMMA MICROELECTRONICS INC. GAMMA reserves the right to make changes without further notice to any products herein. Information provided herein is alleged to be exact and consistent and this publication surpasses and replaces all information previously supplied.

GAMMA makes no warranty the suitability of its products for any particular purpose, nor does GAMMA assume any liability arising out of the application or use of any product or circuit, and specifically disclaims any and all liability including without limitation special, consequential or incidental damages.

GAMMA products are not authorized for using as critical components in life support devices or systems without prior written approval from GAMMA MICROELECTRONICS INC.
