

3A STEP-DOWN VOLTAGE REGULATORS

- 3.3V, 5V, 12V, 15V, Adjustable output versions
- Adjustable version output voltage range 1.23V to 37V $\pm 4\%$ max over line and load conditions
- 3A output current
- Input voltage range 7V to 40V
- Requires only 4 external components
- High efficiency
- TTL shutdown capability, low power standby mode
- Thermal shutdown, current limit protection
- Uses standard inductors
- 52 kHz fixed frequency internal oscillator
- P+ Product Enhancement tested

The GM7130 series of regulators provide all the active functions for a step-down (buck) switching regulator, and drive 3A load with excellent line and load regulation. GM7130's are available in fixed output voltages of 3.3V, 5V, 12V, 15V, and a versatile Adjustable output version. These regulators are simple to use and require a minimum number of external components. Features include internal frequency compensation and a fixed-frequency oscillator. The GM7130 series are high-efficiency replacements for popular three-terminal linear regulators, requiring a smaller heatsink or even no heatsink. The GM7130's perform well with standard inductors from several manufacturers, simplifying the design of switch-mode power supplies. The GM7130 series guarantee $\pm 4\%$ tolerance on output voltage within specified input voltages and output load conditions, and $\pm 10\%$ on the oscillator frequency. External shutdown is included, with 50 μA (typical) standby current. The output switch has cycle-by-cycle current limiting, as well as thermal shutdown for full protection under fault conditions.

Applications:

- Pre-regulator for linear regulators
- High-efficiency step-down buck regulator
- On-card/board switching regulators
- Positive to negative converter (buck-boost)

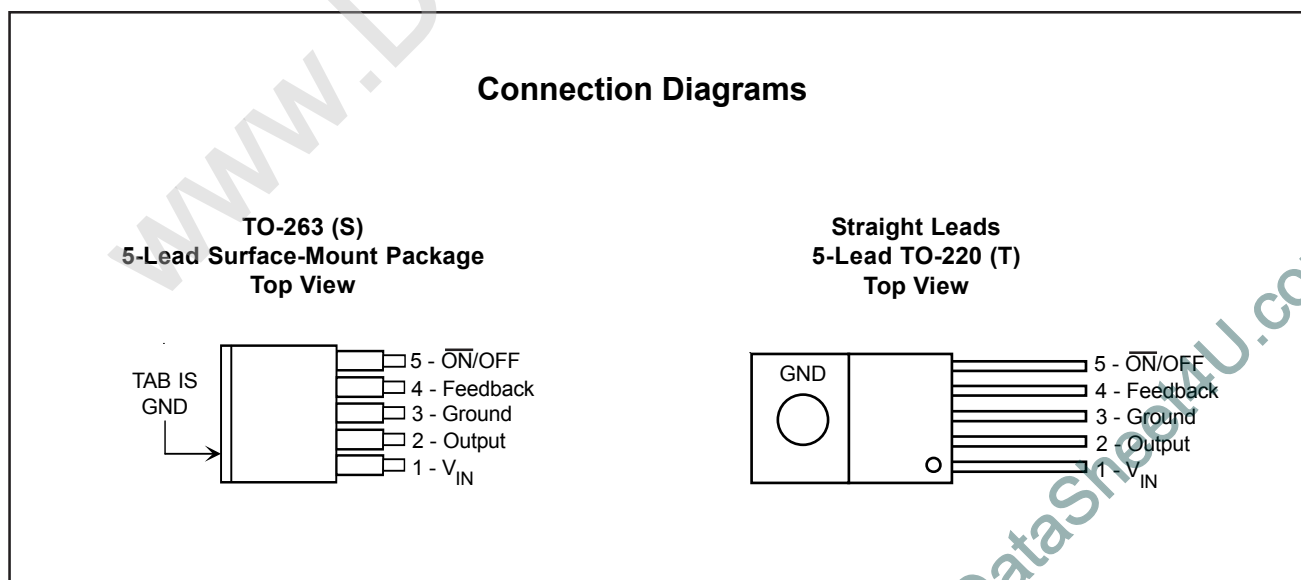

3A STEP-DOWN VOLTAGE REGULATORS
■ Absolute Maximum Ratings

| Rating | Value | Unit |
|--|----------------------------------|------|
| Maximum Supply Voltage | 45 | V |
| $\overline{\text{ON/OFF}}$ Pin Input Voltage | $-0.3 \leq V \leq V_{\text{IN}}$ | V |
| Output Voltage to Ground (Steady State) | -1.0 | V |
| Power Dissipation | Internally Limited | - |
| Storage Temperature Range | -65 to +150 | °C |
| Maximum Junction Temperature | +150 | °C |
| Minimum ESD Rating (C=100pF, R=1.5kΩ) | 2 | kV |
| Lead Temperature (Soldering, 10 seconds) | +260 | °C |

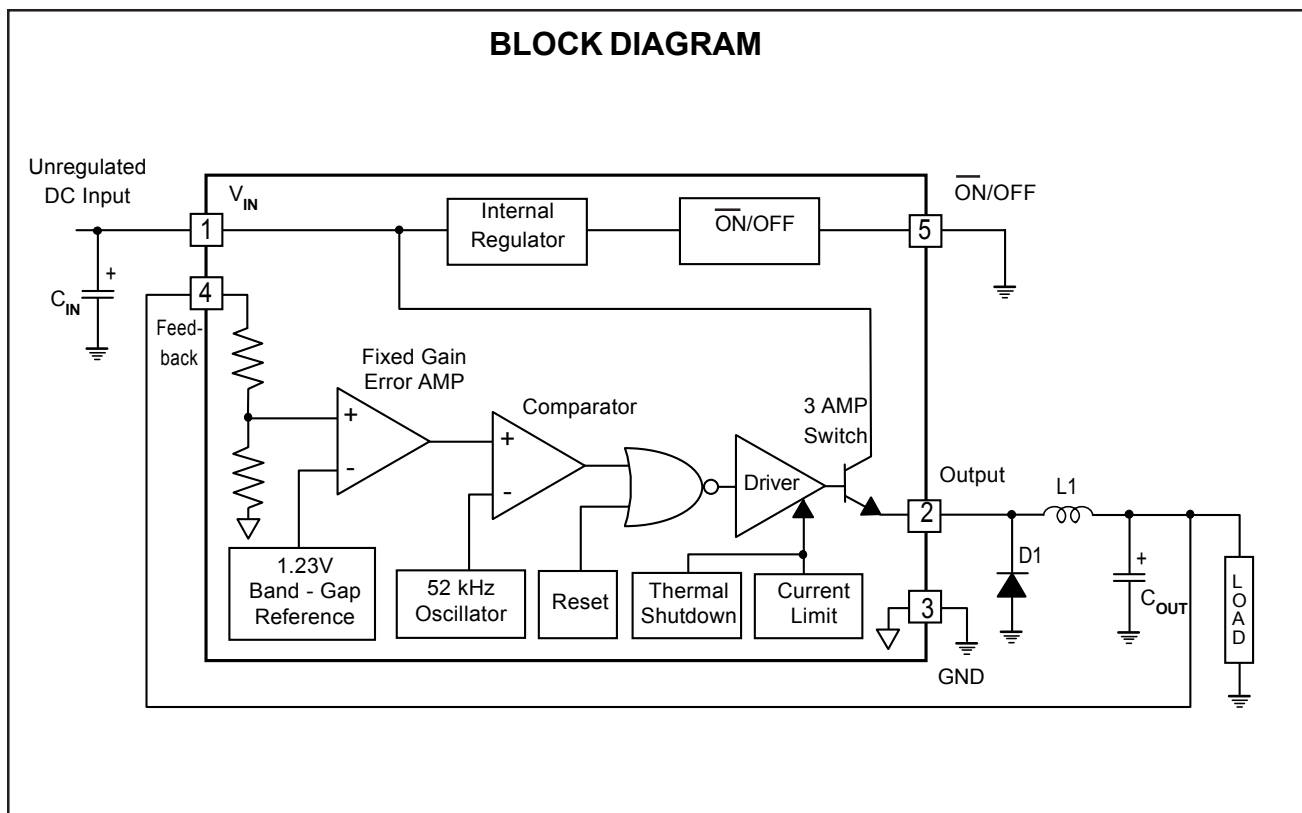

3A STEP-DOWN VOLTAGE REGULATORS
ELECTRICAL CHARACTERISTICS: GM7130-3.3

 (Specifications with standard type face are for $T_J = 25^\circ\text{C}$, and those with **boldface type** apply over full Operating Temperature Range)

| Parameter | Conditions | Symbol | Min | Typ | Max | Unit |
|----------------|--|-----------|----------------------|-----|----------------------|------|
| Output Voltage | $V_{IN} = 12\text{V}$, $I_{LOAD} = 0.5\text{A}$ | V_{OUT} | 3.234 | 3.3 | 3.366 | V |
| Output Voltage | $6\text{V} \leq V_{IN} \leq 40\text{V}$, $0.5\text{A} \leq I_{LOAD} \leq 3.0\text{A}$ | V_{OUT} | 3.168 / 3.135 | 3.3 | 3.432 / 3.465 | V |
| Efficiency | $V_{IN} = 12\text{V}$, $I_{LOAD} = 3.0\text{A}$ | η | - | 75 | - | % |

ELECTRICAL CHARACTERISTICS: GM7130-5.0

 (Specifications with standard type face are for $T_J = 25^\circ\text{C}$, and those with **boldface type** apply over full Operating Temperature Range)

| Parameter | Conditions | Symbol | Min | Typ | Max | Unit |
|----------------|--|-----------|----------------------|-----|----------------------|------|
| Output Voltage | $V_{IN} = 12\text{V}$, $I_{LOAD} = 0.5\text{A}$ | V_{OUT} | 4.900 | 5.0 | 5.100 | V |
| Output Voltage | $8\text{V} \leq V_{IN} \leq 40\text{V}$, $0.5\text{A} \leq I_{LOAD} \leq 3.0\text{A}$ | V_{OUT} | 4.800 / 4.750 | 5.0 | 5.200 / 5.250 | V |
| Efficiency | $V_{IN} = 12\text{V}$, $I_{LOAD} = 3.0\text{A}$ | η | - | 77 | - | % |

ELECTRICAL CHARACTERISTICS: GM7130-12

 (Specifications with standard type face are for $T_J = 25^\circ\text{C}$, and those with **boldface type** apply over full Operating Temperature Range)

| Parameter | Conditions | Symbol | Min | Typ | Max | Unit |
|----------------|---|-----------|----------------------|------|----------------------|------|
| Output Voltage | $V_{IN} = 25\text{V}$, $I_{LOAD} = 0.5\text{A}$ | V_{OUT} | 11.76 | 12.0 | 12.24 | V |
| Output Voltage | $15\text{V} \leq V_{IN} \leq 40\text{V}$, $0.5\text{A} \leq I_{LOAD} \leq 3.0\text{A}$ | V_{OUT} | 11.52 / 11.40 | 12.0 | 12.48 / 12.60 | V |
| Efficiency | $V_{IN} = 15\text{V}$, $I_{LOAD} = 3.0\text{A}$ | η | - | 88 | - | % |

ELECTRICAL CHARACTERISTICS: GM7130-15

 (Specifications with standard type face are for $T_J = 25^\circ\text{C}$, and those with **boldface type** apply over full Operating Temperature Range)

| Parameter | Conditions | Symbol | Min | Typ | Max | Unit |
|----------------|---|-----------|----------------------|------|----------------------|------|
| Output Voltage | $V_{IN} = 25\text{V}$, $I_{LOAD} = 0.5\text{A}$ | V_{OUT} | 14.70 | 15.0 | 15.30 | V |
| Output Voltage | $18\text{V} \leq V_{IN} \leq 40\text{V}$, $0.5\text{A} \leq I_{LOAD} \leq 3.0\text{A}$ | V_{OUT} | 14.40 / 14.25 | 15.0 | 15.60 / 15.75 | V |
| Efficiency | $V_{IN} = 18\text{V}$, $I_{LOAD} = 3.0\text{A}$ | η | - | 88 | - | % |

3A STEP-DOWN VOLTAGE REGULATORS
ELECTRICAL CHARACTERISTICS: GM7130-ADJ

 (Specifications with standard type face are for $T_J = 25^\circ\text{C}$, and those with **boldface type** apply over full Operating Temperature Range)

| Parameter | Conditions | Symbol | Min | Typ | Max | Unit |
|------------------|--|-----------|----------------------|-------|----------------------|------|
| Feedback Voltage | $V_{IN} = 12\text{V}$, $I_{LOAD} = 0.5\text{A}$, $V_{OUT} = 5\text{V}$ | V_{OUT} | 1.217 | 1.230 | 1.243 | V |
| Feedback Voltage | $18\text{V} \leq V_{IN} \leq 40\text{V}$, $0.5\text{A} \leq I_{LOAD} \leq 3.0\text{A}$ $V_{OUT} = 5\text{V}$ | V_{OUT} | 1.193 / 1.180 | 1.230 | 1.267 / 1.280 | V |
| Efficiency | $V_{IN} = 12\text{V}$, $I_{LOAD} = 3\text{A}$, $V_{OUT} = 5\text{V}$ | η | - | 77 | - | % |

ELECTRICAL CHARACTERISTICS: All Output Voltage Versions

 (Specifications with standard type face are for $T_J = 25^\circ\text{C}$, and those with **boldface type** apply over full Operating Temperature Range. Unless otherwise specified, $V_{IN} = 12\text{V}$ for the 3.3V, 5.0V and ADJ version, $V_{IN} = 25\text{V}$ for 12V version, and $V_{IN} = 30\text{V}$ for 15V version. $I_{LOAD} = 500\text{mA}$)

| Parameter | Conditions | Symbol | Min | Typ | Max | Unit |
|----------------------------------|---|---------------|------------------|----------|------------------|--------------------|
| Feedback Bias Current | $V_{OUT} = 5\text{V}$ (Adjustable Version Only) | I_b | - | 50 | 100 / 500 | nA |
| Oscillator Frequency | (Note 11) | f_o | 47 / 42 | 52 | 58 / 63 | kHz |
| Saturation Voltage | $I_{OUT} = 3\text{A}$ (Note 4) | V_{SAT} | - | 1.4 | 1.8 / 2.0 | V |
| Max Duty Cycle (ON) | (Note 5) | DC | 93 | 98 | - | % |
| Current Limit | (Notes 4, 11) | I_{CL} | 4.2 / 3.5 | 5.8 | 6.9 / 7.5 | A |
| Output Leakage Current | (Notes 6, 7) Output = 0 V Output = -1 V | I_L | - - | - 7.5 | 2 30 | mA |
| Quiescent Current | (Note 6) | I_Q | - | 5 | 10 | mA |
| Standby Quiescent Current | $\overline{\text{ON}}$ / OFF Pin = 5V (OFF) | I_{STBY} | - | 50 | 200 | μA |
| Thermal Resistance | T Package, Junction to Ambient (Note 8) | θ_{JA} | - | 65 | - | $^\circ\text{C/W}$ |
| | T Package, Junction to Ambient (Note 8) | θ_{JA} | - | 45 | - | |
| | T Package, Junction to Case | θ_{JC} | - | 2 | - | |
| | T Package, Junction to Ambient (Note 10) | θ_{JA} | - | 50 | - | |
| $\overline{\text{ON}}$ / OFF Pin | $V_{OUT} = 0\text{V}$ | V_{IH} | 2.2 / 2.4 | 1.4 | - | V |
| Logic Input Level | $V_{OUT} = \text{Nominal Output Voltage}$ | V_{IL} | - | 1.2 | 1.0 / 0.8 | V |
| ON / OFF Pin Current | $\overline{\text{ON}}$ / OFF Pin = 5V (OFF) | V_{IH} | - | 12 | 30 | μA |
| | $\overline{\text{ON}}$ / OFF Pin = 0V (ON) | I_{IL} | - | 0 | 10 | μA |

3A STEP-DOWN VOLTAGE REGULATORS**■ ELECTRICAL CHARACTERISTICS NOTES**

Note 1: Absolute Maximum Ratings indicate limits beyond which damage to the device may occur. Operating Ratings indicate conditions for which the device is intended to be functional, but do not guarantee specific performance limits. Guaranteed specifications and test conditions are shown in Electrical Characteristics.

Note 2: All limits guaranteed at 25° C (standard type face) and over full operating temperature range (bold type face). All 25° C limits are 100% production tested. All limits over full operating temperature range are guaranteed via correlation using standard Statistical Quality Control methods.

Note 3: External components such as the catch diode, inductor, input and output capacitors can affect switching regulator system performance. When the GM7130 is used as shown in the Figure 2 test circuit, system performance will be as shown in system parameters section of Electrical Characteristics.

Note 4: Output pin sourcing current. No diode, inductor or capacitor connected to output.

Note 5: Feedback pin removed from output and connected to 0V.

Note 6: Feedback pin removed from output and connected to +12V for the Adjustable, 3.3V, and 5V versions, and +25V for the 12V and 15V versions, to force the output transistor OFF.

Note 7: $V_{IN} = 40V$

Note 8: Junction to ambient thermal resistance (no external heat sink) for the 5 lead TO-220 package mounted vertically, with $\frac{1}{2}$ inch leads in a socket, or on a PC board with minimum copper area.

Note 9: Junction to ambient thermal resistance (no external heat sink) for the 5 lead TO-220 package mounted vertically, with $\frac{1}{4}$ inch leads soldered to a PC board containing approximately 4 square inches of copper area surrounding the leads.

Note 10: If the TO-263 package is used, the thermal resistance can be reduced by increasing the PC board copper area thermally connected to the package. Using 0.5 square inches of copper area, θ_{JA} is 50°C/W, with 1 square inch of copper area, θ_{JA} is 37°C/W, and with 1.6 or more square inches of copper area, θ_{JA} is 32°C/W.

Note 11: The oscillator frequency reduces to approximately 11 kHz in the event of an output short or an overload which causes the regulated output voltage to drop approximately 40% from the nominal output voltage. This self-protection feature lowers the average power dissipation of the GM7130 by lowering the minimum duty cycle from 5% down to approximately 2%.

3A STEP-DOWN VOLTAGE REGULATORS
■ TEST CIRCUIT AND LAYOUT GUIDELINES

Careful layout is important with any switching regulator. Rapidly switching currents associated with wiring inductance generate voltage transients which can cause problems. To minimize inductance and ground loops, the lengths of the leads indicated by heavy lines in Figure 2 below should be kept as short as possible. Single-point grounding (as indicated in Figure 2) or ground plane construction should be used for best results. When using the Adjustable version, place the programming resistors as close as possible to the GM7130, to keep the sensitive feedback wiring short.

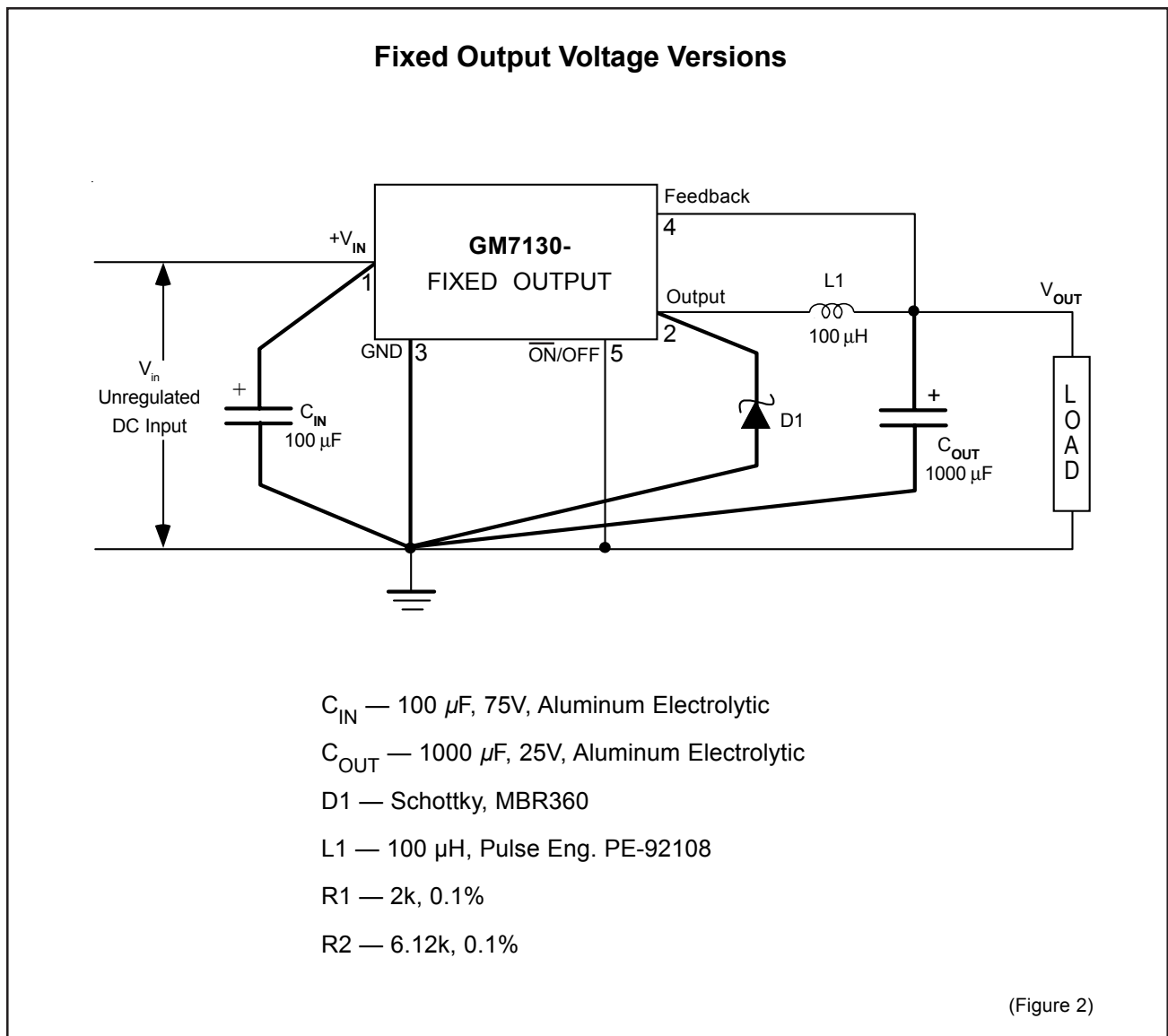

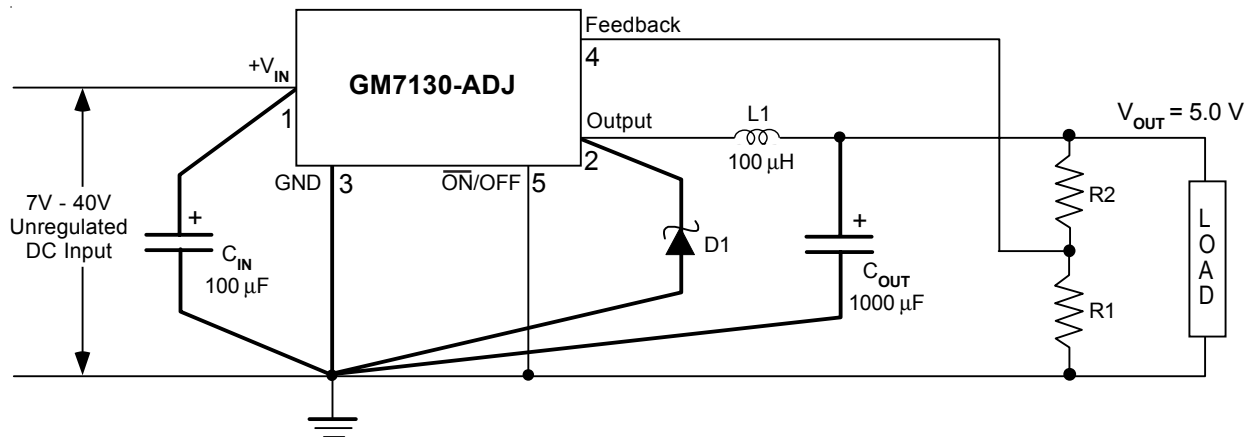
3A STEP-DOWN VOLTAGE REGULATORS
Adjustable Output Voltage Versions

$$V_{OUT} = V_{REF} \left(1 + \frac{R2}{R1} \right)$$

$$R2 = R1 \left(\frac{V_{OUT}}{V_{REF}} - 1 \right)$$

where $V_{REF} = 1.23V$, $R1$ between 1k and 5k.

(Figure 2)

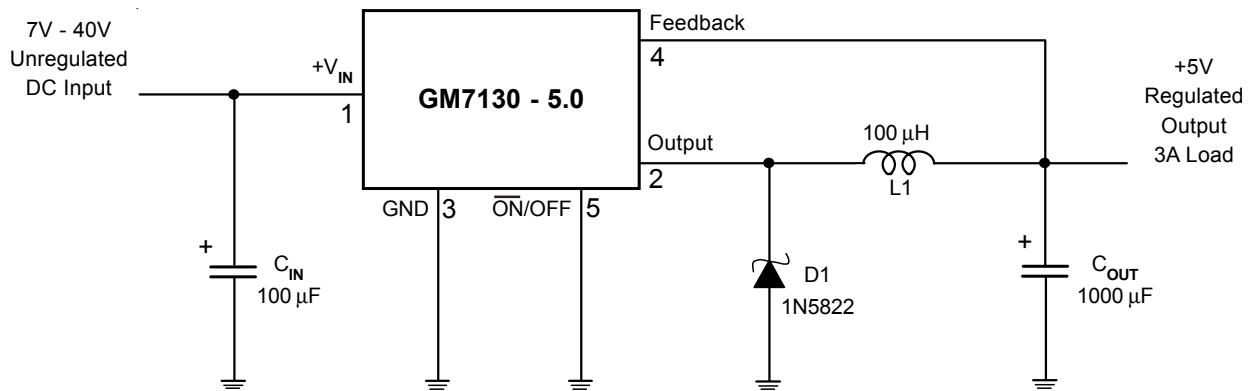
TYPICAL APPLICATION (Fixed Output Voltage Versions)

3A STEP-DOWN VOLTAGE REGULATORS

 ■ **ORDERING INFORMATION**

| | PACKAGE | Output Voltage | | | | |
|--------|-----------|----------------|---------------|---------------|--------------|--------------|
| | | ADJ. | 3.3V | 5.0V | 12V | 15V |
| GM7130 | TO- 263-5 | GM7130-ATA5 | GM7130-3.3TA5 | GM7130-5.0TA5 | GM7130-12TA5 | GM7130-15TA5 |
| | TO- 220-5 | GM7130-ATB5 | GM7130-3.3TB5 | GM7130-5.0TB5 | GM7130-12TB5 | GM7130-15TB5 |

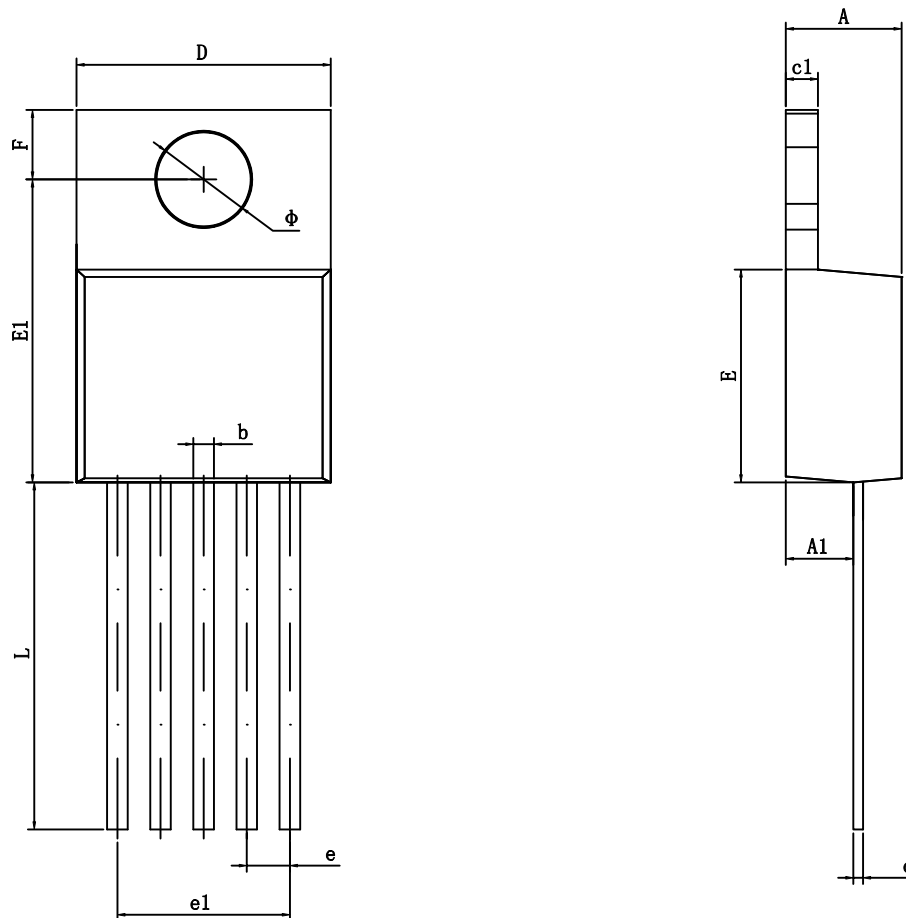
3A STEP-DOWN VOLTAGE REGULATORS
TO-220-5L PACKAGE OUTLINE DIMENSIONS

| Symbol | Dimensions In Millimeters | | Dimensions In Inches | |
|--------|---------------------------|--------|----------------------|-------|
| | Min | Max | Min | Max |
| A | 4.470 | 4.670 | 0.176 | 0.184 |
| A1 | 2.520 | 2.820 | 0.099 | 0.111 |
| b | 0.710 | 0.910 | 0.028 | 0.036 |
| c | 0.310 | 0.530 | 0.012 | 0.021 |
| c1 | 1.170 | 1.370 | 0.046 | 0.054 |
| D | 9.850 | 10.150 | 0.388 | 0.400 |
| E | 8.200 | 8.600 | 0.323 | 0.339 |
| E1 | 11.760 | 12.160 | 0.463 | 0.479 |
| e | 1.700TYP | | 0.067TYP | |
| e1 | 6.700 | 6.900 | 0.264 | 0.272 |
| F | 2.590 | 2.890 | 0.102 | 0.114 |
| L | 13.500 | 13.900 | 0.531 | 0.547 |
| ϕ | 3.790 | 3.890 | 0.149 | 0.153 |

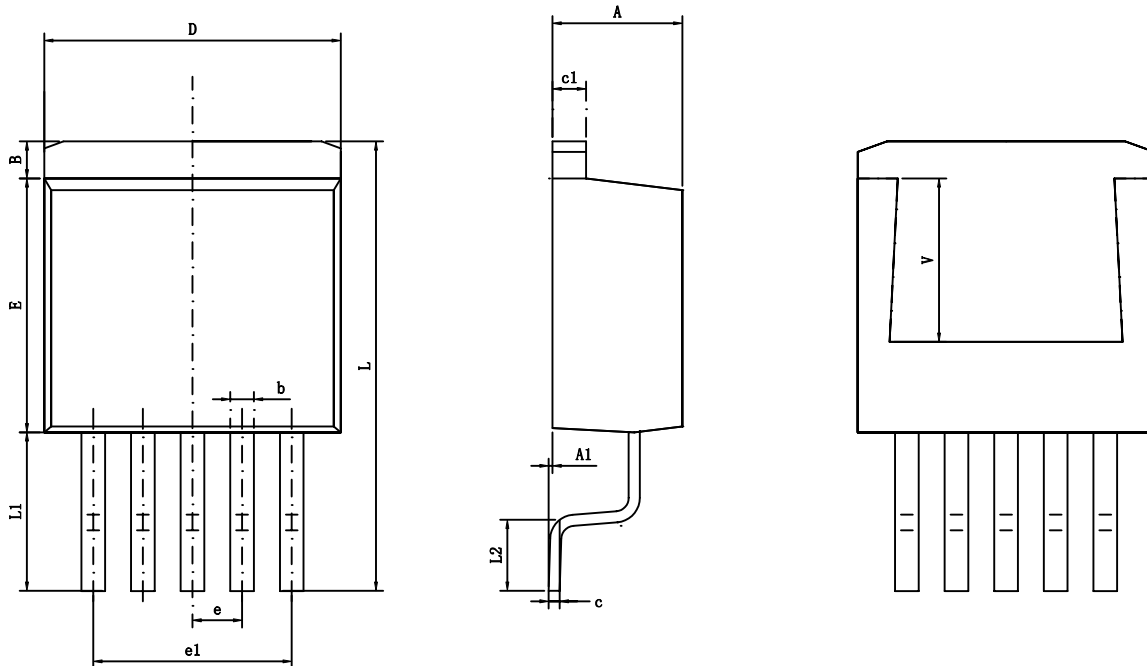
3A STEP-DOWN VOLTAGE REGULATORS
TO-263-5L PACKAGE OUTLINE DIMENSIONS

| Symbol | Dimensions In Millimeters | | Dimensions In Inches | |
|--------|---------------------------|--------|----------------------|-------|
| | Min | Max | Min | Max |
| A | 4.470 | 4.670 | 0.176 | 0.184 |
| A1 | 0.000 | 0.150 | 0.000 | 0.006 |
| B | 1.560 | 1.760 | 0.061 | 0.069 |
| b | 0.710 | 0.910 | 0.028 | 0.036 |
| c | 0.310 | 0.530 | 0.012 | 0.021 |
| c1 | 1.170 | 1.370 | 0.046 | 0.054 |
| D | 9.880 | 10.180 | 0.389 | 0.401 |
| E | 8.200 | 8.600 | 0.323 | 0.339 |
| e | 1.700TYP | | 0.067TYP | |
| e1 | 6.700 | 6.900 | 0.264 | 0.272 |
| L | 15.140 | 15.540 | 0.596 | 0.612 |
| L1 | 5.080 | 5.480 | 0.200 | 0.216 |
| L2 | 2.340 | 2.740 | 0.092 | 0.108 |
| V | 5.600REF | | 0.220REF | |