

---

# 622 Mb/s Single Mode Laser Transceiver for ATM, SONET OC-12/SDH STM-4 (L4.1)

## Technical Data

### Features

- **SC Duplex Single Mode Transceiver**
- **Link Distances up to 40 km with 9/125  $\mu$ m SMF**
- **Fully Class 1 CDRH/IEC 825 Compliant**
- **Long Reach SONET OC-12/SDH STM-4 (L4.1) Compliant**
- **Single +5 V Power Supply Operation and PECL Logic Interfaces**
- **Industry Standard Multi-sourced 1 x 9 Mezzanine Package Style**
- **Wave Solder and Aqueous Wash Process Compatible**
- **Interchangeable with LED Multisourced 1 x 9 Transceivers**

### Applications

- **SONET/SDH Equipment Interconnect, STS-12/SDH STM-4 Rate**
- **Long Reach (Up to 40 km) ATM Links**

### Description

The HFCT-5218 transceiver is a high performance, cost effective module for serial optical data communications applications specified for a signal rate of 622 MBd. It is designed to provide a SONET/SDH compliant link for 622 Mb/s long reach links.

This module is designed for single mode fiber and operates at a nominal wavelength of 1300 nm. It incorporates high performance, reliable, long wavelength optical devices and proven circuit technology to give long life and consistent service.

The transmitter section uses an advanced Distributed Feedback (DFB) laser with full IEC 825 and CDRH Class 1 eye safety.

A pseudo-ECL logic interface simplifies interface to external circuitry.

---

### HFCT-5218M Family

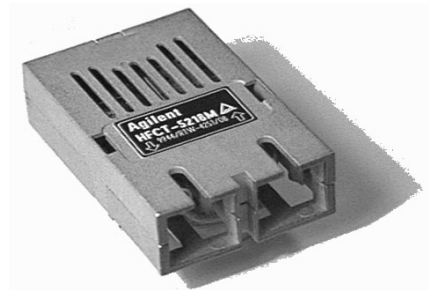

### Functional Description

#### Receiver Section Design

The receiver section contains an InGaAs/InP photodetector and a preamplifier within the receptacle, coupled to a postamp/decision circuit on a separate circuit board.

The postamplifier is ac coupled to the preamplifier as illustrated in Figure 1. The coupling capacitor is large enough to pass the SONET/SDH test pattern at 622 Mbd without significant distortion or performance penalty. If a lower signal rate, or a code which has significantly more low frequency content is used, sensitivity, jitter and pulse distortion could be degraded.

Figure 1 also shows a filter network which limits the bandwidth of the preamp output signal. The filter is designed to bandlimit the preamp output noise and thus improve the receiver sensitivity.

These components will also reduce the sensitivity of the receiver as the signal bit rate is increased above 622 Mbd.

## Transmitter Section

### Design

The transmitter section uses a distributed feedback laser as its optical source. The package of this laser is designed to allow repeatable coupling into single mode fiber. In addition, this package has been designed to be compliant with IEC 825 eye safety requirements under any

single fault condition. The optical output is controlled by a custom IC which detects the laser output via the monitor photodiode, as shown in Figure 2. This IC provides both dc and ac current drive to the laser to ensure correct modulation, eye diagram and extinction ratio over temperature, supply voltage and life

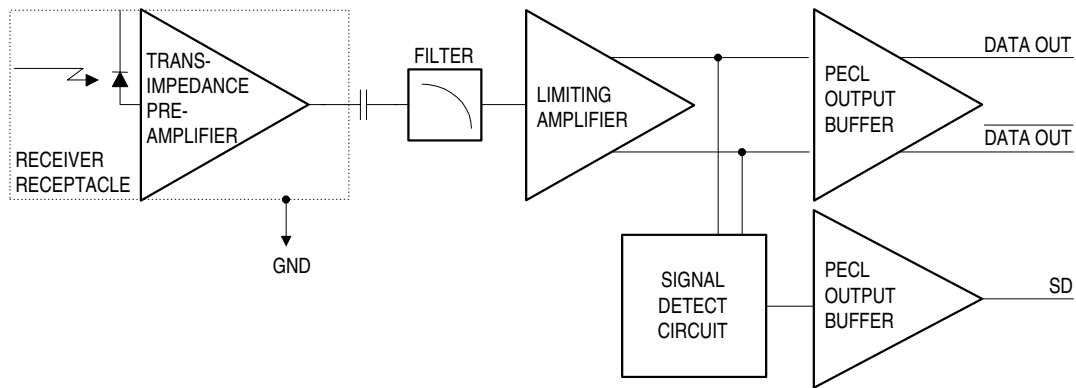

Figure 1. Receiver Block Diagram

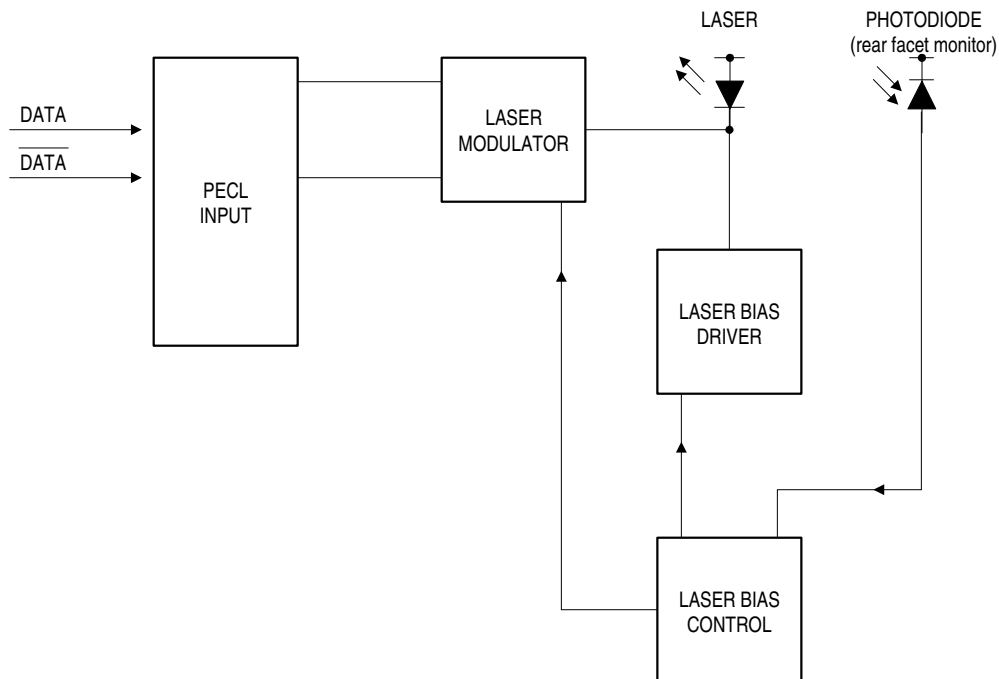

Figure 2. Simplified Transmitter Schematic

## Applications Information

### Recommended Circuit Schematic

When designing the HFCT-5218M circuit interface, there are a few fundamental guidelines to follow. For example, in the Recommended Circuit Schematic, Figure 3, the differential PECL data lines should be treated as 50 Ohm Microstrip or stripline transmission lines. This will help to minimize the parasitic inductance and capacitance effects. Proper termination of the differential data signal will prevent reflections and ringing which would compromise the signal fidelity and generate unwanted electrical noise. Locate terminations at the received signal end of the transmission line. The terminations should be the standard Thevenin-equivalent 50 ohm to  $V_{CC} - 2$  V termination. Other standard PECL terminating techniques may be used. The length of these lines should be kept short and of equal length to prevent pulse-width distortion from occurring. For the high-speed signal lines, differential signals should be used, not single-ended signals. These differential signals need to be loaded symmetrically to prevent unbalanced currents from flowing which will cause distortion in the signal.

The Signal Detect (SD) output of the receiver is PECL logic and must be loaded if it is to be used. The signal detect circuit is much slower than the data path, so the ac noise generated by an asymmetrical load is negligible. Power consumption may be reduced by using a higher than normal load impedance for the SD output. Transmission line effects are not generally a problem as the switching rate is slow.

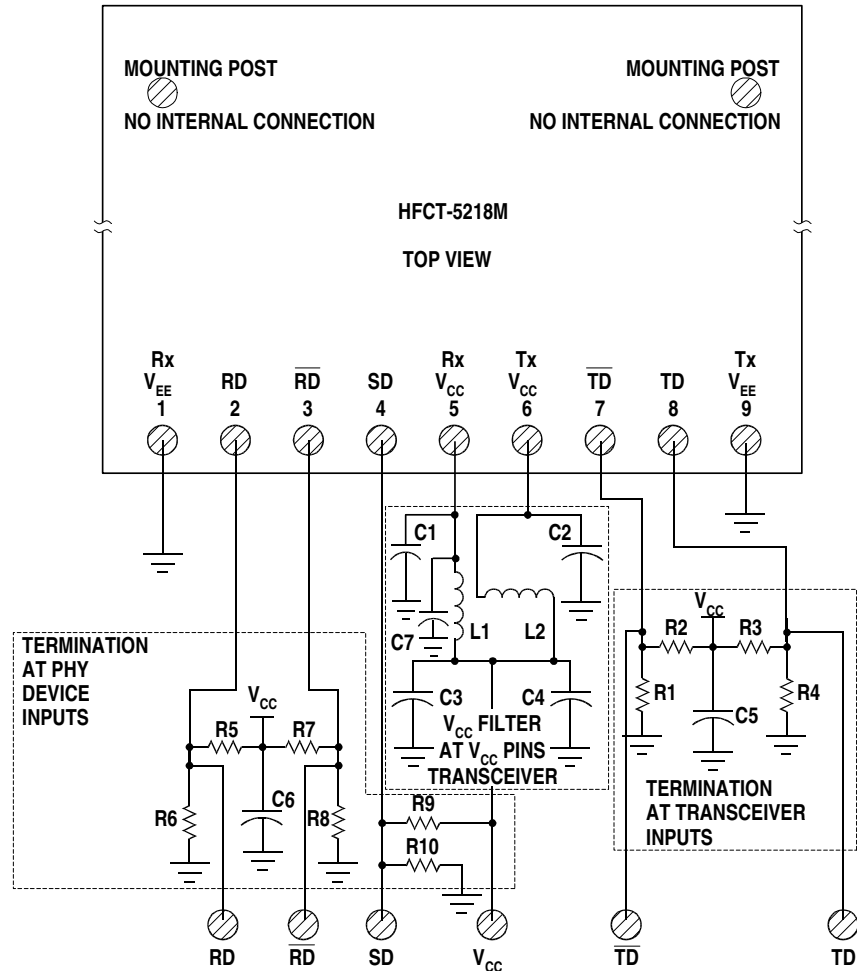

#### NOTES:

THE SPLIT-LOAD TERMINATIONS FOR PECL SIGNALS NEED TO BE LOCATED AT THE INPUT OF DEVICES RECEIVING THOSE PECL SIGNALS. RECOMMEND MULTI-LAYER PRINTED CIRCUIT BOARD WITH 50 OHM MICROSTRIP OR STRIPLINE SIGNAL PATHS BE USED.

$R1 = R4 = R6 = R8 = R10 = 130$  OHMS.

$R2 = R3 = R5 = R7 = R9 = 82$  OHMS.

$C1 = C2 = C3 = C5 = C6 = 0.1$   $\mu$ F.

$C4 = C7 = 10$   $\mu$ F.

$L1 = L2 = 1$   $\mu$ H COIL OR FERRITE INDUCTOR (see text comments).

**Figure 3. Recommended Circuit Schematic for dc Coupling (at +5 V) between Optical Transceiver and Physical Layer IC**

Maintain a solid, low inductance ground plane for returning signal currents to the power supply. Multilayer plane printed circuit board is best for distribution of  $V_{CC}$ , returning ground currents, forming transmission lines and shielding. Also, it is important to suppress noise from influencing the fiber-optic transceiver performance, especially the receiver

circuit. Proper power supply filtering of  $V_{CC}$  for this transceiver is accomplished by using the recommended separate filter circuits shown in Figure 3. These filter circuits suppress  $V_{CC}$  noise greater than 100 mV peak-to-peak or less over a broad frequency range. This prevents receiver sensitivity degradation. It is recommended that surface-

mount components be used. Use tantalum capacitors for the 10  $\mu\text{F}$  capacitors and mono-lithic, ceramic bypass capacitors for the 0.1  $\mu\text{F}$  capacitors. Also, it is recommended that a surface-mount coil inductor of 1  $\mu\text{H}$  be used. Ferrite beads can be used to replace the coil inductors when using quieter  $V_{\text{CC}}$  supplies, but a coil inductor is recommended over a ferrite bead to provide low frequency noise filtering as well. Coils with a low, series dc resistance ( $<0.7$  ohms) and high, self-resonating frequency are recommended. All power supply components need to be placed physically next to the  $V_{\text{CC}}$  pins of the receiver and transmitter. Use a good, uniform ground plane with a minimum number of holes to provide a low-inductance ground current return path for the signal and power supply currents.

Although the front mounting posts make contact with the metallized housing these posts should not be relied upon to provide adequate electrical connection to the plated housing. It is recommended to either connect these front posts to chassis ground or allow them to remain unconnected. These front posts should not be connected to signal ground.

Figure 4 shows the recommended board layout pattern.

In addition to these recommendations, Agilent's Application Engineering staff is available for consulting on best layout practices with various vendors serializer/deserializer, clock generator.

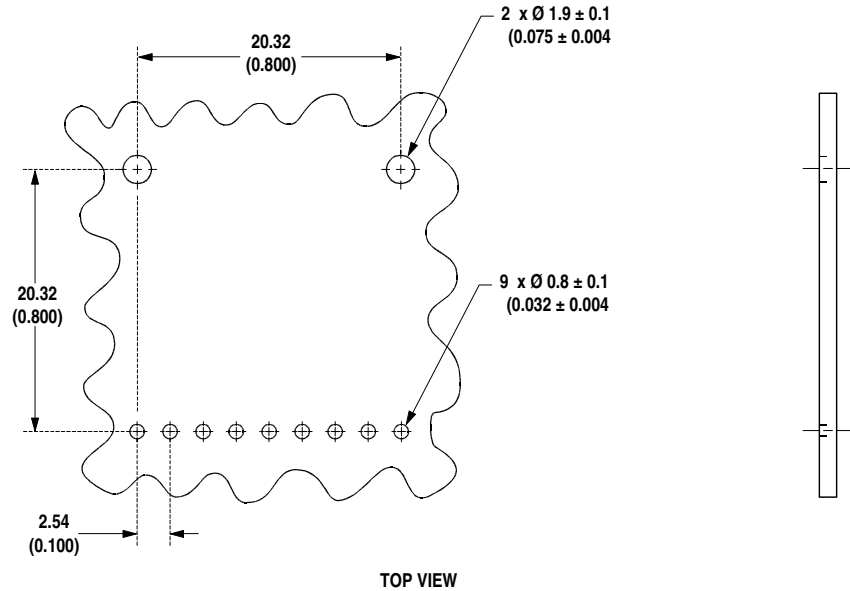

DIMENSIONS ARE IN MILLIMETERS (INCHES)

Figure 4. Recommended Board Layout Pattern

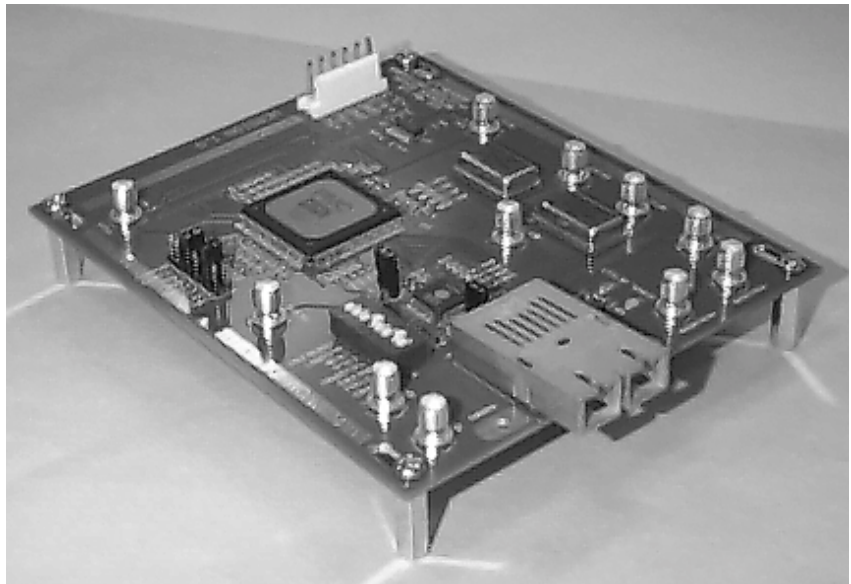

Figure 5. 622.08 Mb/s OC-12 ATM-SONET/SDH Reference Design Board

#### Reference Design

Agilent has developed a reference design for multimode and single-mode OC-12 ATM-SONET/SDH applications shown in Figure 5. This reference design uses a Vitesse Semiconductor Inc.'s VSC8117 clock recovery/clock generation/serializer/deserializer integrated circuit and a PMC-Sierra Inc. PM5355 framer IC.

Application Note 1178 documents the design, layout, testing and performance of this reference design. Gerber files, schematic and application note are available from the Agilent Fiber-Optics Components' web site at the URL of <http://semiconductor.agilent.com/fiber>.

## Electromagnetic Interference (EMI)

One of a circuit board designer's foremost concerns is the control of electromagnetic emissions from electronic equipment. Success in controlling generated Electromagnetic Interference (EMI) enables the designer to pass a governmental agency's EMI regulatory standard; and more importantly, it reduces the possibility of interference to neighboring equipment. There are three options available for the HFCT-5218M with regard to EMI shielding for providing the designer with a means to achieve good EMI performance. The EMI performance of an enclosure using these transceivers is dependent on the chassis design. Agilent encourages using standard RF suppression practices and avoiding poorly EMI-sealed enclosures. In addition, Agilent advises that for the best EMI performance, the metalized case must be connected to chassis ground using one of the shield options.

An un-shielded option, shown in Figure 6 is available for the HFCT-5218M fiber optic transceiver. This unit is intended for applications where EMI is either not an issue for the designer, or the unit resides in a highly-shielded enclosure.

The first shielded option, option EM, is for applications where the position of the transceiver module will extend outside the equipment enclosure. The metallized plastic package and integral external metal shield of the transceiver helps locally to terminate EM fields to the chassis to prevent their emissions outside the enclosure. This metal shield contacts the panel or enclosure

on the inside of the aperture on all but the bottom side of the shield and provides a good RF connection to the panel. This option can accommodate various panel or enclosure thicknesses, i.e. 1.02 mm (.04 in) min to 2.54 mm (0.1 in) max. The reference plane for this panel thickness variation is from the front surface of the panel or enclosure. The recommended length for protruding the HFCT-5218EM transceiver beyond the front surface of the panel or enclosure is 6.35 mm (0.25 in) . With this option, there is flexibility of positioning the module to fit the specific need of the enclosure design. (See Figure 7 for the mechanical drawing dimensions of this shield.)

The second shielded option, option FM, is for applications that are designed to have a flush mounting of the module with respect to the front of the panel or enclosure. The flush-mount design accommodates a large variety of panel thickness, i.e. 1.02 mm (.04 in) min to 2.54 mm (0.1 in) max. Note the reference plane for the flush-mount design is the interior side of the panel or enclosure. The recommended distance from the centerline of the transceiver front solder posts to the inside wall of the panel is 13.82 mm (0.544 in) . This option contacts the inside panel or enclosure wall on all four sides of this metal shield. (See Figure 8 for the mechanical drawing dimensions of this shield.)

Both shielded design options connect only to the equipment chassis and not to the signal or logic ground of the circuit board within the equipment closure. The front panel aperture dimensions are recommended in

Figures 9 and 10. When layout of the printed circuit board is done to incorporate these metal-shielded transceivers, keep the area on the printed circuit board directly under the external metal shield free of any components and circuit board traces. For additional EMI performance advantage, use duplex SC fiber-optic connectors that have low metal content inside the connector. This lowers the ability of the metal fiber-optic connectors to couple EMI out through the aperture of the panel or enclosure.

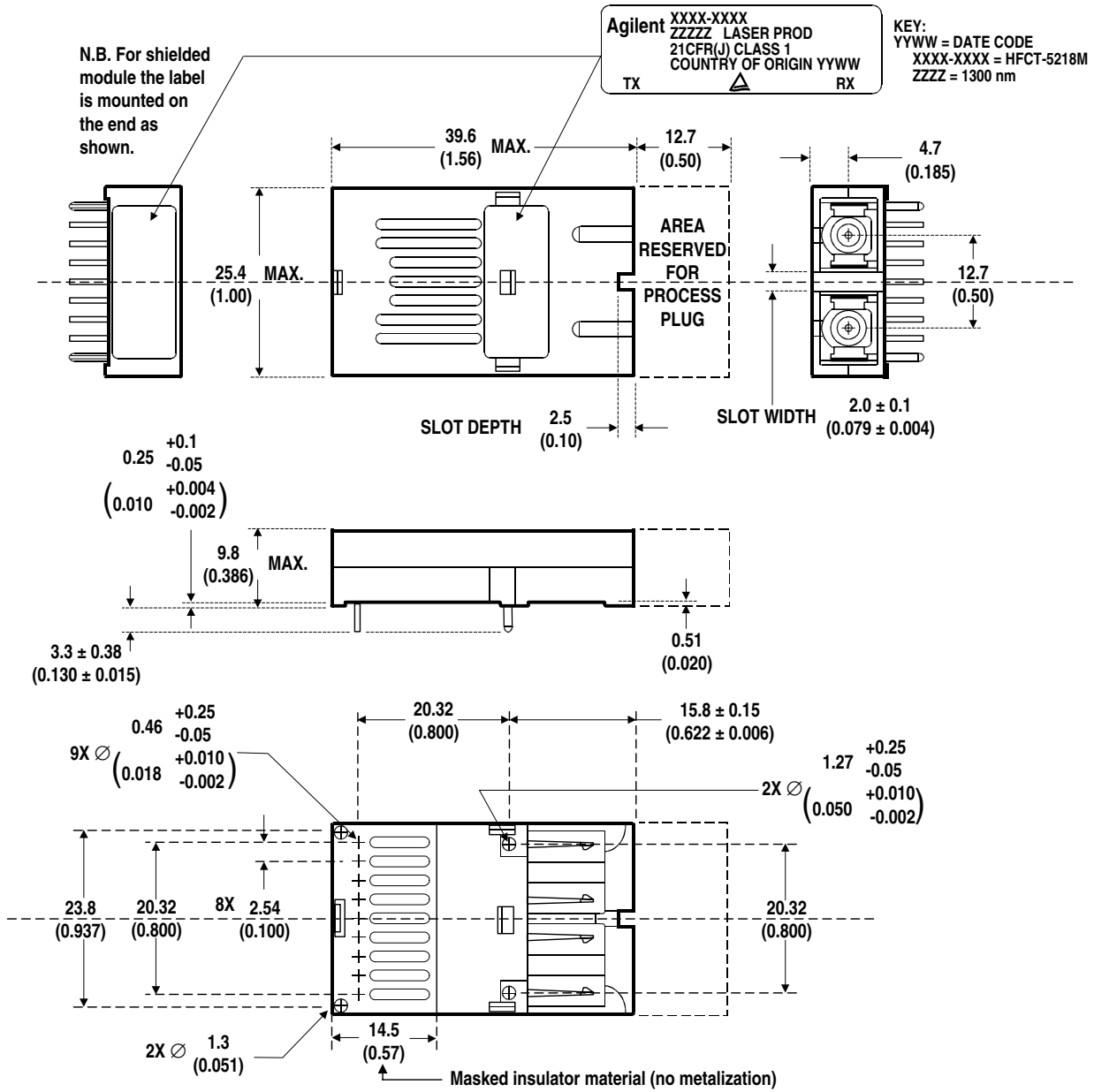

DIMENSIONS ARE IN MILLIMETERS (INCHES).

TOLERANCES: X.XX  $\pm 0.025$  mm  
X.X  $\pm 0.05$  mm UNLESS OTHERWISE SPECIFIED.

Figure 6. Package Outline Drawing for HFCT-5218M

### Recommended Solder and Wash Process

The HFCT-5218M is compatible with industry-standard wave or hand solder processes.

### HFBR-5000 Process Plug

The HFCT-5218M transceiver is supplied with a process plug, the HFBR-5000, for protection of the optical ports with the Duplex SC connector receptacle. This process plug prevents contamination during wave solder and aqueous rinse as well as during handling, shipping or storage. It is made of high-temperature, molded, sealing material that will withstand +80°C and a rinse pressure of 110 lb/in<sup>2</sup>.

### Recommended Solder Fluxes and Cleaning/Degreasing Chemicals

Solder fluxes used with the HFCT-5218M fiber-optic transceiver should be water-soluble, organic solder fluxes. Some recommended solder fluxes are Lonco 3355-11 from London Chemical West, Inc. of Burbank, CA, and 100 Flux from Alpha-metals of Jersey City, NJ.

Recommended cleaning and degreasing chemicals for the HFCT-5218M are alcohols (methyl, isopropyl, isobutyl), aliphatics (hexane, heptane) and other chemicals, such as soap solution or naphtha. Do not use partially halogenated hydrocarbons for cleaning/degreasing. Examples of chemicals to avoid are 1,1,1 trichloroethane, ketones (such as MEK), acetone, chloroform, ethyl acetate, methylene dichloride, phenol, methylene chloride or N-methylpyrrolidone.

### Regulatory Compliance

These transceiver products are intended to enable commercial system designers to develop equipment that complies with the various regulations governing certification of Information Technology Equipment. See the Regulatory Compliance Table for details. Additional information is available from your Agilent sales representative.

### Electrostatic Discharge (ESD)

There are two design cases in which immunity to ESD damage is important.

The first case is during handling of the transceiver prior to mounting it on the circuit board. It is important to use normal ESD handling precautions for ESD sensitive devices. These precautions include using grounded wrist straps, work benches, and floor mats in ESD controlled areas.

## Regulatory Compliance

Feature	Test Method	Performance
Electrostatic Discharge (ESD)	HBM TA-NWT-000983	Min 2000 V
	Machine Model JEDEC JESD22-A115-A	Min 100 V
	RAD IEC-61000-4-2	Products of this design typically withstand at least 25 kV without damage.
Electromagnetic Interference (EMI)	FCC Class B CENELEC EN55022 Class B (CISPR 22B) VCCI Class 2	Margins are dependant on customer board and chassis design. It is recommended that the flush mount shield design (HFCT-5218FM) is used for best EMI margin to FCC B.
Immunity	Variation of IEC 801-3	Typically show no measurable effect from a 10 V/m field swept from 26 to 1000 MHz applied to the transceiver when mounted to a circuit card without a chassis enclosure.
Eye Safety	IEC 825/CDRH Class 1	CDRH Accession Numbers: HFCT-5218xx ⇒ 9521220 - 23 TUV Bauart License: HFCT-5218xx ⇒ 933/510908/01

The second case to consider is static discharges to the exterior of the equipment chassis containing the transceiver parts. To the extent that the duplex SC connector receptacle is exposed to the outside of the equipment chassis, it may be subject to whatever ESD system level test criteria that the equipment is intended to meet.

### **Electromagnetic Interference (EMI)**

Most equipment designs utilizing these high-speed transceivers from Agilent will be required to meet the requirements of FCC in the United States, CENELEC EN55022 (CISPR 22) in Europe and VCCI in Japan.

The HFCT-5218M EMI has been characterized with a chassis enclosure to demonstrate robustness of the parts. Performance of a system containing these transceivers will vary depending on the individual chassis design.

### **Immunity**

Equipment utilizing these HFCT-5218 transceivers will be subject to radio-frequency electromagnetic fields in some environments. These transceivers, with their integral shields, have been characterized without the benefit of a normal equipment chassis enclosure and the results are reported below. Performance of a system containing these transceivers within a well-designed chassis is expected to be better than the results of these tests without a chassis enclosure.

### **Eye Safety**

The HFCT-5218M transceiver is classified as AEL Class I (U.S. 21 CFR(J) and AEL Class 1 per EN 60825-1 (+A11). It is eye safe when used within the data sheet limits per CDRH. It is also eye safe under normal operating conditions and under all reasonably foreseeable single fault conditions per EN60825-1. Agilent has tested the transceiver design for compliance with the requirements listed below under normal operating conditions and under single fault conditions where applicable. TUV Rheinland has granted certification to this transceiver for laser eye safety and use in EN 60950 and EN 60825-2 applications. It's performance enables the transceiver to be used without concern for eye safety up to 5.25 V transmitter  $V_{CC}$  under single fault conditions.



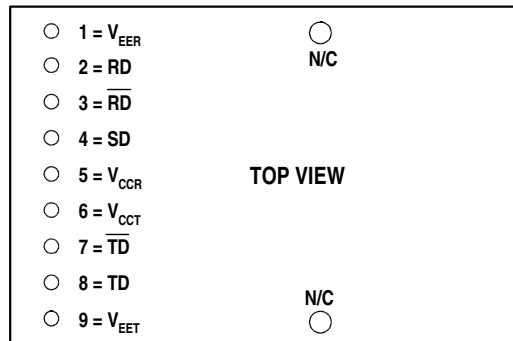

N/C = NO INTERNAL CONNECTION (MOUNTING POSTS) - CONNECT TO CHASSIS GROUND OR LEAVE FLOATING, DO NOT CONNECT TO SIGNAL GROUND.

**Table 1. Pinout Table**

Pin	Symbol	Functional Description
Mounting Studs		The mounting studs are provided for transceiver mechanical attachment to the circuit boards, they are embedded in the metalized plastic housing and are not connected to the transceiver internal circuit. They should be soldered into plated-through holes on the printed circuit board and not connected to signal ground.
1	$V_{EER}$	Receiver Signal Ground Directly connect this pin to receiver signal ground plane. Receiver $V_{EER}$ and transmitter $V_{EET}$ can connect to a common circuit board ground plane.
2	RD+	Receiver Data Out Terminate this high-speed, differential, PECL output with standard PECL techniques at the follow-on device input pin.
3	RD-	Receiver Data Out Bar Terminate this high-speed, differential, PECL output with standard PECL techniques at the follow-on device input pin.
4	SD	Signal Detect Normal input optical signal levels to the receiver result in a logic "1" output ( $V_{OH}$ ). Low input optical signal levels to the receiver result in a fault condition indication shown by a logic "0" output ( $V_{OL}$ ). If Signal Detect output is not used, leave it open-circuited.  This Signal Detect output can be used to drive a PECL input on an upstream circuit, such as, Signal Detect input or Loss of Signal-bar.
5	$V_{CCR}$	Receiver Power Supply Provide +5 V dc via the recommended receiver $V_{CCR}$ power supply filter circuit. Locate the power supply filter circuit as close as possible to the $V_{CCR}$ pin.
6	$V_{CCT}$	Transmitter Power Supply Provide +5 V dc via the recommended transmitter $V_{CCT}$ power supply filter circuit. Locate the power supply filter circuit as close as possible to the $V_{CCT}$ pin.
7	TD-	Transmitter Data In Bar Terminate this high-speed, differential, Transmitter Data input with standard PECL techniques at the transmitter input pin.
8	TD+	Transmitter Data In Terminate this high-speed, differential, Transmitter Data input with standard PECL techniques at the transmitter input pin.
9	$V_{EET}$	Transmitter Signal Ground Directly connect this pin to the transmitter signal ground plane. Transmitter $V_{EET}$ and receiver $V_{EER}$ can connect to a common circuit board ground plane.

## Performance Specifications

### Absolute Maximum Ratings

Absolute maximum limits mean that no catastrophic damage will occur if the product is subjected to these ratings for short periods, provided each limiting parameter is in isolation and all other parameters have values within the performance specification. It should not be assumed that limiting values of more than one parameter can be applied to the product at the same time

Parameter	Symbol	Minimum	Maximum	Units
Storage Temperature	$T_s$	-40	+85	°C
Operating Temperature	-	0	+70	°C
Lead Soldering Temperature/Time	-	-	+240/10	°C/s
Output Current (other outputs)	$I_{OUT}$	0	30	mA
Input Voltage	-	GND	V <sub>CC</sub>	V
Power Supply Voltage	-	0	6	V

### Operating Environment

Parameter	Symbol	Minimum	Maximum	Units
Power Supply Voltage	V <sub>CC</sub>	+4.75	+5.25	V
Ambient Operating Temperature	T <sub>OP</sub>	0	+70	°C
Power Supply Rejection	PSR		100	mV

### Transmitter Section

(Ambient Operating Temperature, V<sub>CC</sub> = 4.75 V to 5.25 V)

Parameter	Symbol	Minimum	Maximum	Units	Notes
Output Center Wavelength	$\lambda_{ce}$	1280	1335	nm	-
Output Spectral Width (-20 dB)	$\Delta\lambda$	-	1	nm	-
Output Optical Power	P <sub>O</sub>	-3.0	+2.0	dBm	1
Extinction Ratio	E <sub>R</sub>	10	-	dB	-
Power Supply Current	I <sub>CC</sub>	-	140	mA	2
Output Eye	Compliant with Bellcore TR-NWT-000253 and ITU recommendation G.957				

### Receiver Section

(Ambient Operating Temperature, V<sub>CC</sub> = 4.75 V to 5.25 V)

Parameter	Symbol	Minimum	Typical	Maximum	Units	Notes
Receiver Sensitivity	-	-28	-	-	dBm	3
Maximum Input Power	-	-	-	-7.0	dBm	-
Alarm ON	-	-42	-	-34	dBm	-
Hysteresis	-	0.5	-	4.0	dB	4
Power Supply Current	I <sub>CC</sub>	-	130	150	mA	5
Data Outputs PECL						
Alarm Output PECL						

#### Notes:

- Output power is power coupled into a single mode fiber. Minimum output optical level is at end of life.
- The power supply current varies with temperature. Maximum current is specified at V<sub>CC</sub> = Maximum @ maximum temperature (not including terminations) and end of life.
- Minimum sensitivity and saturation levels measured for a BER of 10<sup>-10</sup> with a 2<sup>23</sup>-1 PRBS with 72 ones and 72 zeros inserted. (CCITT recommendation G.958).
- A high to low transition in SD typically occurs for a Rx bit error rate (BER) of 10<sup>-6</sup> or worse.
- The current excludes the output load current.

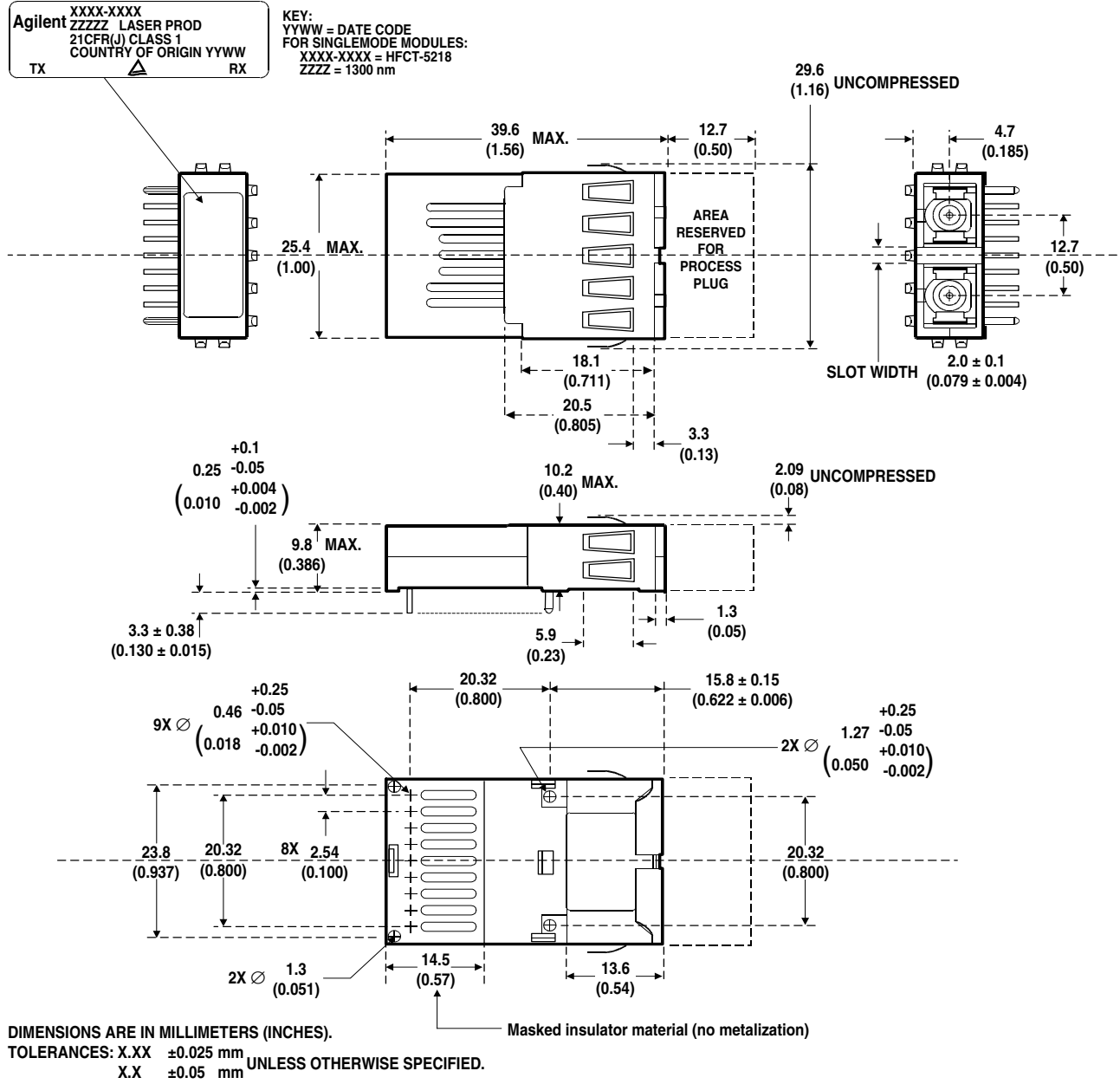
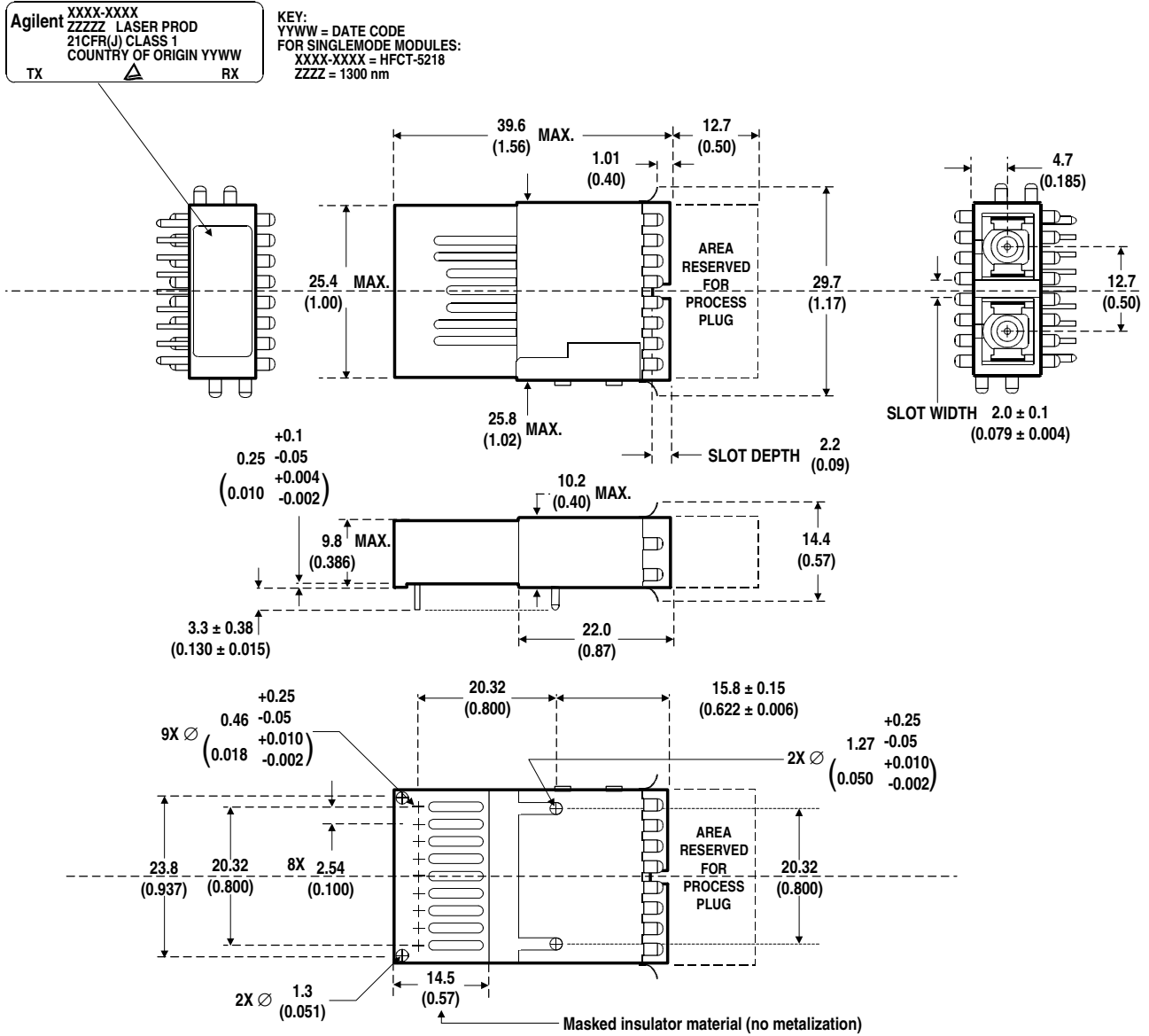
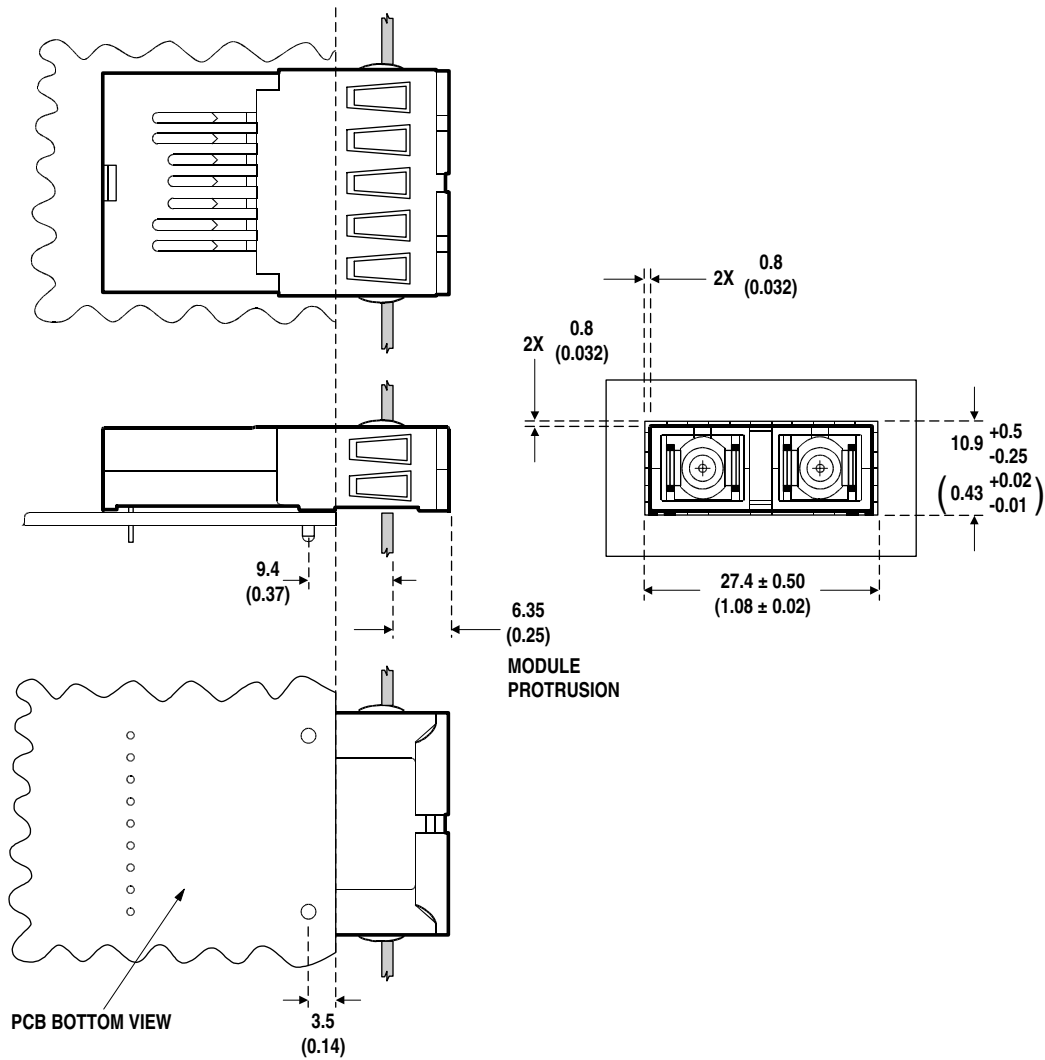

Figure 7. Package Outline for HFCT-5218EM



DIMENSIONS ARE IN MILLIMETERS (INCHES).  
 TOLERANCES: X.XX ±0.025 mm  
 X.X ±0.05 mm UNLESS OTHERWISE SPECIFIED.

Figure 8. Package Outline for HFCT-5218FM



DIMENSIONS ARE IN MILLIMETERS (INCHES).

TOLERANCES: X.XX ±0.025 mm UNLESS OTHERWISE SPECIFIED.  
X.X ±0.05 mm

Figure 9. Suggested Module Positioning and Panel Cut-out for HFCT-5218EM

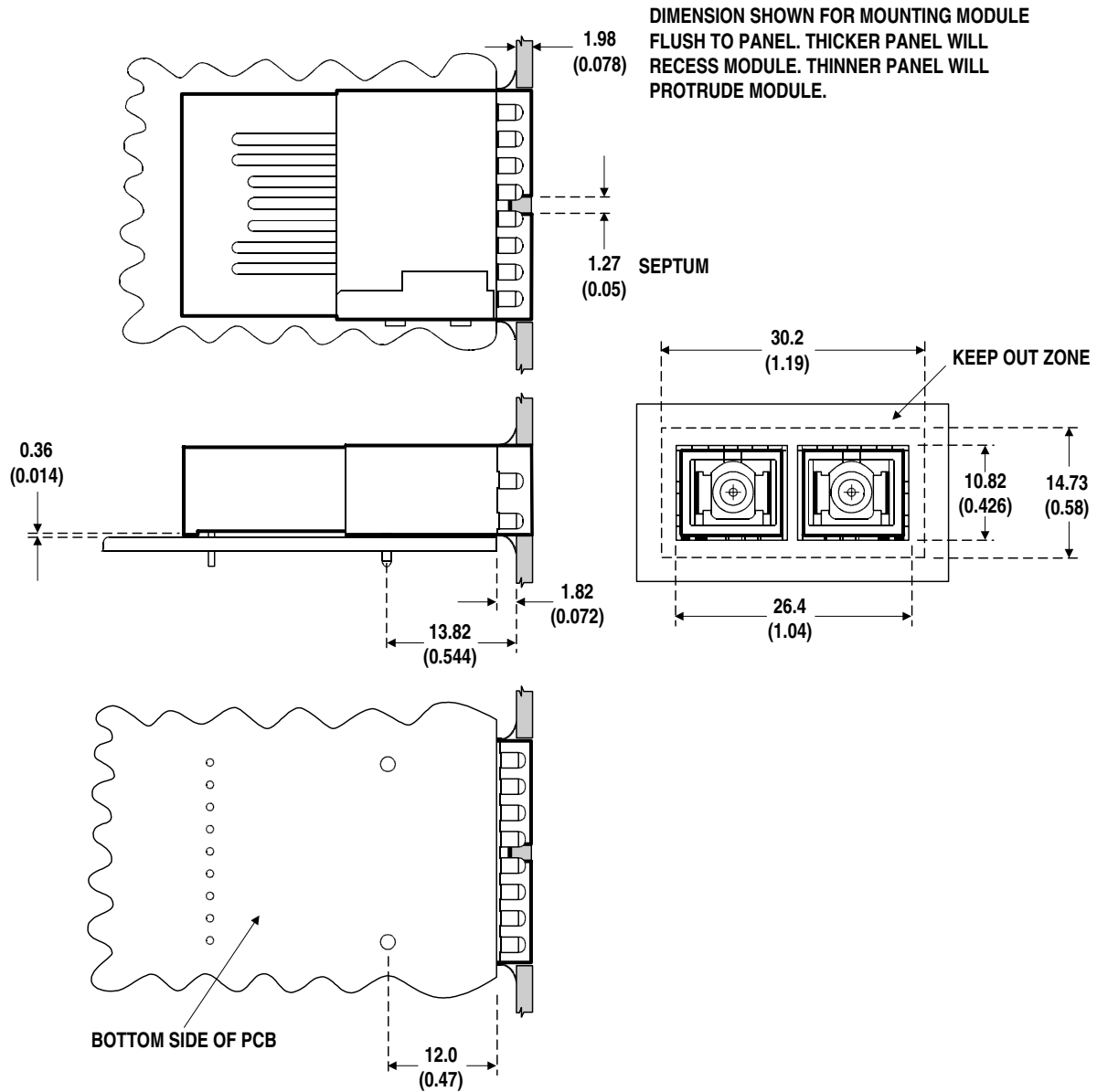

DIMENSIONS ARE IN MILLIMETERS (INCHES).  
 TOLERANCES: X.XX ±0.025 mm UNLESS OTHERWISE SPECIFIED.  
 X.X ±0.05 mm

Figure 10. Suggested Module Positioning and Panel Cut-out for HFCT-5218FM

## Ordering Information

### 1300 nm DFB Laser

HFCT-5218M	No shield, metallized housing.
HFCT-5218EM	Extended/protruding shield, metallized housing.
HFCT-5218FM	Flush shield, metallized housing.

## Supporting Documentation

HFCT-5208xxx/HFCT-5218xx	Application Note
HFCT-5218M	Characterization Report
HFCT-5208M/HFCT-5218M	Interim Qualification Report
HFBR-5208M/HFCT-5208M/HFCT-5218M	Reference Design Application Note 1178

**Class 1 Laser Product:** This product conforms to the applicable requirements of 21 CFR 1040 at the date of manufacture

Date of Manufacture: \_\_\_\_\_

Agilent Technologies Ltd., Whitehouse Road, Ipswich, England

## Handling Precautions

1. The HFCT-5218M can be damaged by current surges or overvoltage. Power supply transient precautions should be taken.
2. Normal handling precautions for electrostatic sensitive devices should be taken.

