

Description

The GM23C4000A high performance read only memory is organized as 524,288 words by eight bit and has an access time of 120/150ns. It is designed to be compatible with all microprocessors and similar applications where high performance large-bit storage and simple interfacing are important considerations. The GM23C4000A offers automatic power down controlled by the Chip Enable (\overline{CE}) input. The GM23C4000A is packaged in a 32 DIP, provides polarity programmable \overline{CE} and \overline{OE} buffer as user option mode.

Features

- 524,288 x 8 bit Organization
- Single + 5V Supply
- Access Time : 120/150ns (Max)
- Operating current : 50mA (Max)
- Standby current : 50μA (Max)
- TTL-compatible inputs and outputs
- Polarity programmable chip enable and out enable pin
- 3-State outputs for wired-OR expansion
- Fully static operation
- Package :
 GM23C4000A : 32 Pin Plastic DIP (600 mil)
 GM23C4000AFW : 32 Pin Plastic SOP (525 mil)

Pin Description

Pin	Function
A0-A18	Address Inputs
O0-O7	Data Outputs
\overline{CE}/CE^*	Chip Enable Input
\overline{OE}/OE^*	Output Enable Input
Vcc	Power Supply (+5V)
Vss	Ground
NC	No Connection

*User Selectable Polarity.

Pin Configuration

32 DIP/SOP

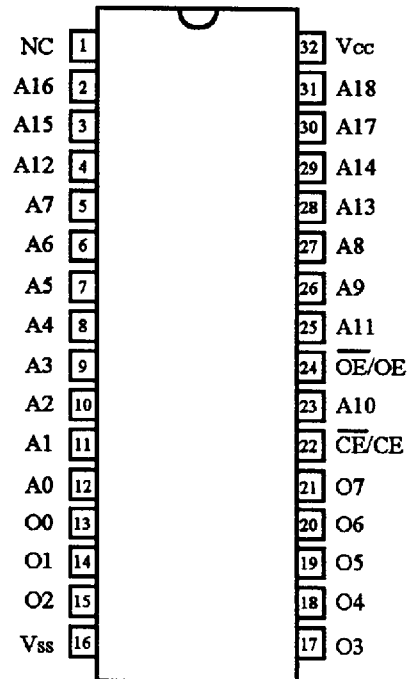

(Top View)

Block Diagram

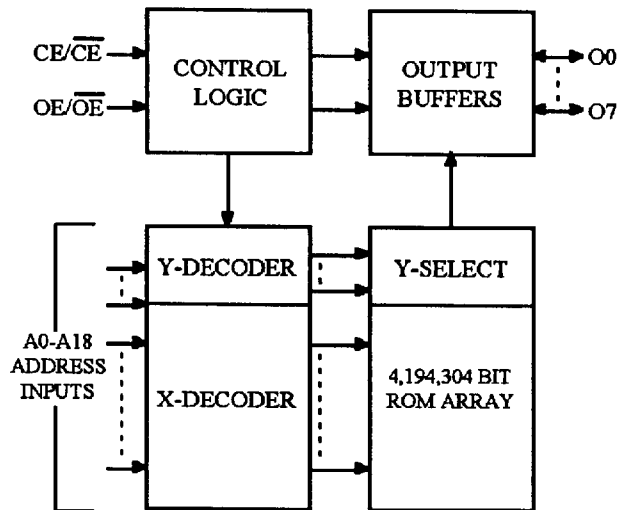

Absolute Maximum Ratings*

Symbol	Parameter	Rating	Unit
T _A	Ambient Operating Temperature	-10 ~ 80	°C
T _{STG}	Storage Temperature	-65 ~ 150	°C
V _{CC}	Supply Voltage to Ground Potential	-0.5 ~ V _{CC} + 0.5	V
V _{OUT}	Output Voltage	-0.5 ~ V _{CC} + 0.5	V
V _{IN}	Input Voltage	-0.5 ~ 7.0	V

***Comments**

Stresses above those listed under "Absolute Maximum Ratings" may cause permanent damage to the device. These are stress ratings only. Functional operation of this device at these or any other conditions above those indicated in the operational sections of this specification is not implied and exposure to absolute maximum rating conditions for extended periods may affect device reliability.

Recommended DC Operating Conditions (V_{CC} = 5.0V ± 10%, T_A = 0 ~ 70°C)

Symbol	Parameter	Min	Typ	Max	Unit
V _{CC}	Supply Voltage	4.5	5.0	5.5	V
V _{SS}	Supply Voltage	0	0	0	V
V _{IH}	Input High Voltage	2.2	-	V _{CC} + 0.3	V
V _{IL}	Input Low Voltage	-0.3	-	0.8	V

DC Electrical Characteristics (V_{CC} = 5.0V ± 10%, T_A = 0 ~ 70°C)

Symbol	Parameter	Condition	Min	Typ	Max	Unit
V _{OH}	Output High Voltage	I _{OH} = -1mA	2.4			V
V _{OL}	Output Low Voltage	I _{OL} = 2.1mA			0.4	V
I _{I(L)}	Input Leakage Current	V _{IN} = 0V to V _{CC}			± 10	μA
I _{O(L)}	Output Leakage Current	V _{OUT} = 0V to V _{CC}			± 10	μA
I _{CC}	Operating Supply Current (f = 6.7 MHz)	$\overline{CE} = V_{IL}, CE = V_{IH}$			50	mA
I _{SB1}	Standby Current (TTL)	$\overline{CE} = V_{IH}$, all Output Open			1	mA
I _{SB2}	Standby Current (CMOS)	$\overline{CE} = V_{CC}$, all Output Open			50	μA

Capacitance (T_A = 25°C, f = 1.0 MHz)

Symbol	Parameter	Condition	Min	Max	Unit
C _I	Input Capacitance	V _{IN} = 0V		10	pF
C _O	Output Capacitance	V _{OUT} = 0V		10	pF

Note : Capacitance is periodically sampled and not 100% tested.

Mode Selection

CE/ $\overline{\text{CE}}$	OE/ $\overline{\text{OE}}$	Mode	Data	Power
L/H	X	Standby	High Z	Standby
H/L	L/H	Operating	High Z	Active
	H/L		Door	

AC Operating Characteristics ($V_{CC} = 5.0V \pm 10\%$, $T_A = 0 \sim 70^\circ\text{C}$)

Symbol	Parameter	GM23C4000A-12		GM23C4000A-15		Unit
		Min	Max	Min	Max	
t_{RC}	Read Cycle Time	120		150		ns
t_{ACE}	Chip Enable Access Time		120		150	ns
t_{AA}	Address Access Time		120		150	ns
t_{AOE}	Output Enable Access Time		60		70	ns
t_{OH}	Output Hold From Address Change	10		10		ns
t_{OHZ} t_{CHZ}	Output or Chip Disable to Output High-Z		50		60	ns
t_{OLZ} t_{CLZ}	Output or Chip Enable to Output Low-Z	10		10		ns

AC Test Condition

Input Pulse Level	0.4V to 2.4V
Input Rise and Fall Time	10ns
Input and Output Timing Level	0.8V to 2.0V
Output Load	See Fig. 1

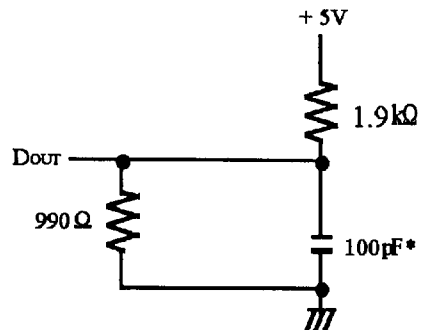

*Including scope and jig.

Fig. 1 Output Load Circuit

Timing Waveforms

Read

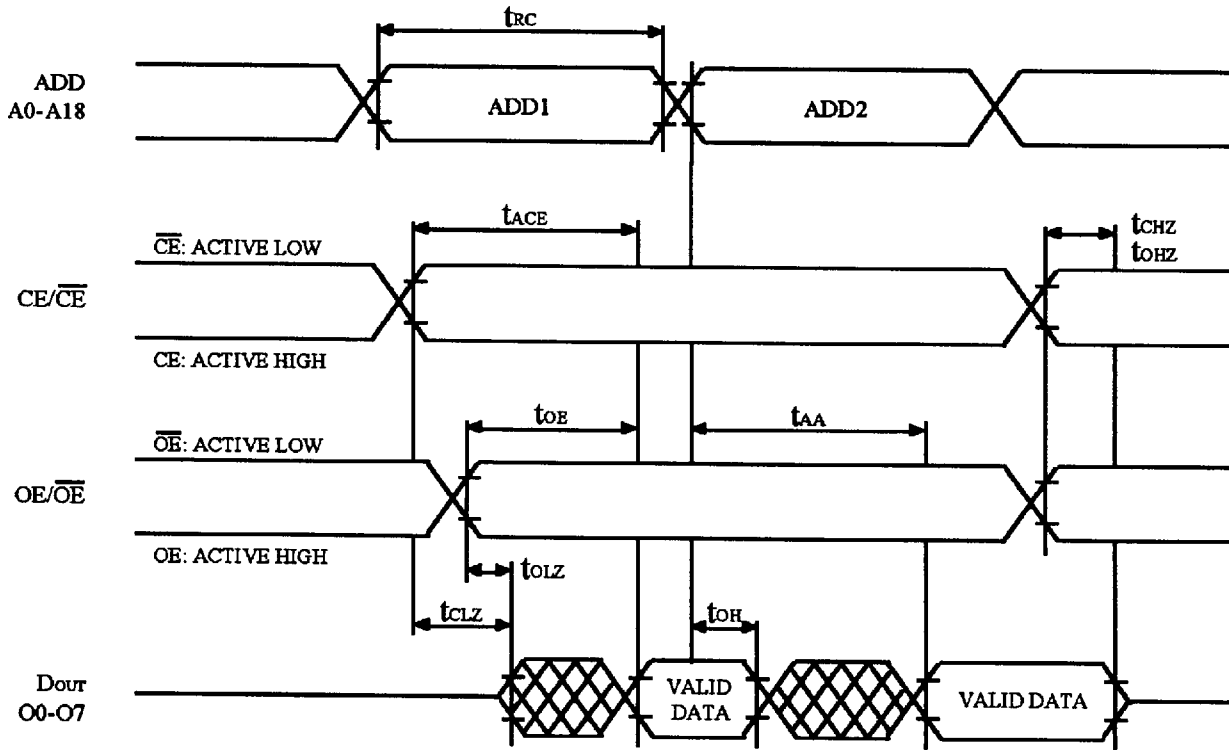

Package Dimensions

Unit: Inches (mm)

32 DIP - B

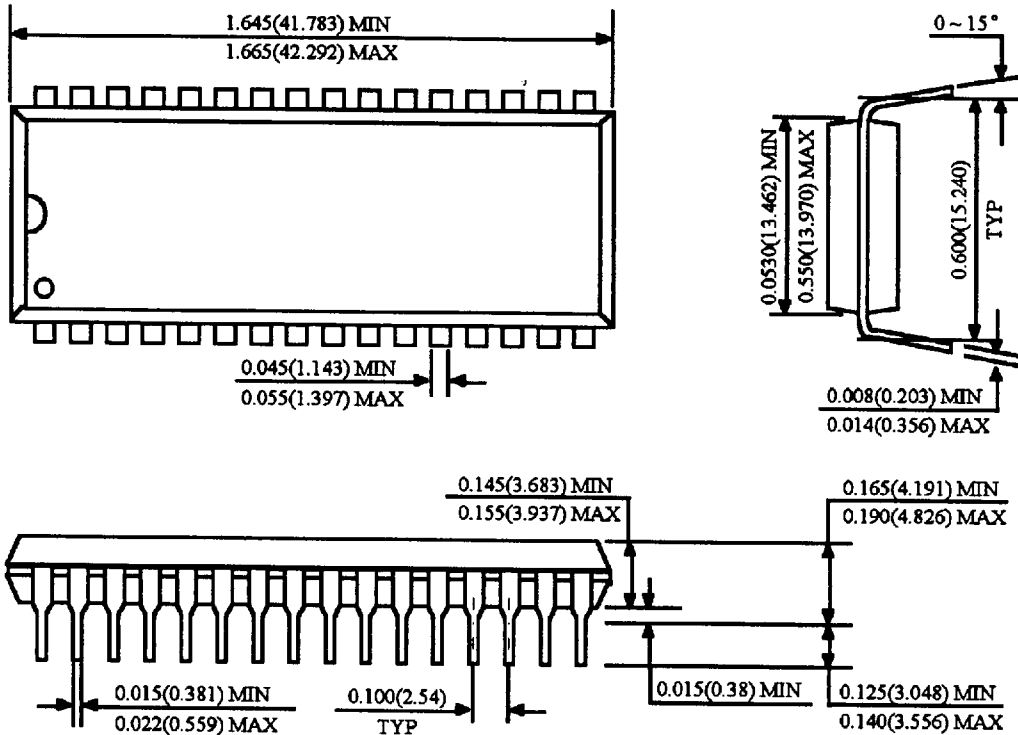

32 SOP - B

