

GENERAL DESCRIPTION

The CM2730 dual LDO family are positive linear voltage regulators developed utilizing CMOS technology. CM2730 contains two LDOs, one with pre-set output voltage (master LDO1), the other with adjustable output voltage (slave LDO2). Each LDO owns its input voltage, bandgap reference voltage, and protection circuit, which reduce noise and cross talk between two LDOs. This dual LDO family is featured low quiescent current (60µA typ.), low dropout voltage, and high output voltage accuracy. Built-in low on-resistance transistor provides low dropout voltage and large output current. 2.2µF or greater can be used as an output capacitors.

The PTSSOP-8 package is recommended for configuring portable devices and large current application, respectively.

These robust devices are designed to prevent device failure under the worst operation condition with both Thermal Shutdown and Current Fold-back.

FEATURES

- ◆ Very Low Shutdown Current < 2.0µA
- ◆ Very Low Dropout Voltage: 300mV @ 300mA
- ◆ Low Current Consumption: Typ. 60µA, Max. 70µA
- ◆ Output Voltage: master LDO1 fixed at 2.5V or 3.3V, and the slave LDO2 adjustable voltage
- ◆ Output Current Range: 0mA ~ 300mA per LDO
- ◆ PTSSOP-08 Package with Power Pad
- ◆ High Accuracy Output Voltage: +/- 1.5%
- ◆ Input Range of 2.6V to 7.0V
- ◆ Independent Thermal Shutdown
- ◆ Power Sequence
- ◆ Power Good Output Function
- ◆ Independent Bandgap
- ◆ Current Limiting
- ◆ Factory Pre-set Output Voltages
- ◆ Short Circuit Current Fold-Back
- ◆ Low Temperature Coefficient

APPLICATIONS

- ◆ Battery-powered devices
- ◆ Personal communication devices
- ◆ Home electric/electronic appliances
- ◆ PC peripherals

24 Hours Technical Support--WebSIM

Champion provides customers an online circuit simulation tool called WebSIM. You could simply logon our website at www.champion-micro.com for details.

PIN CONFIGURATION

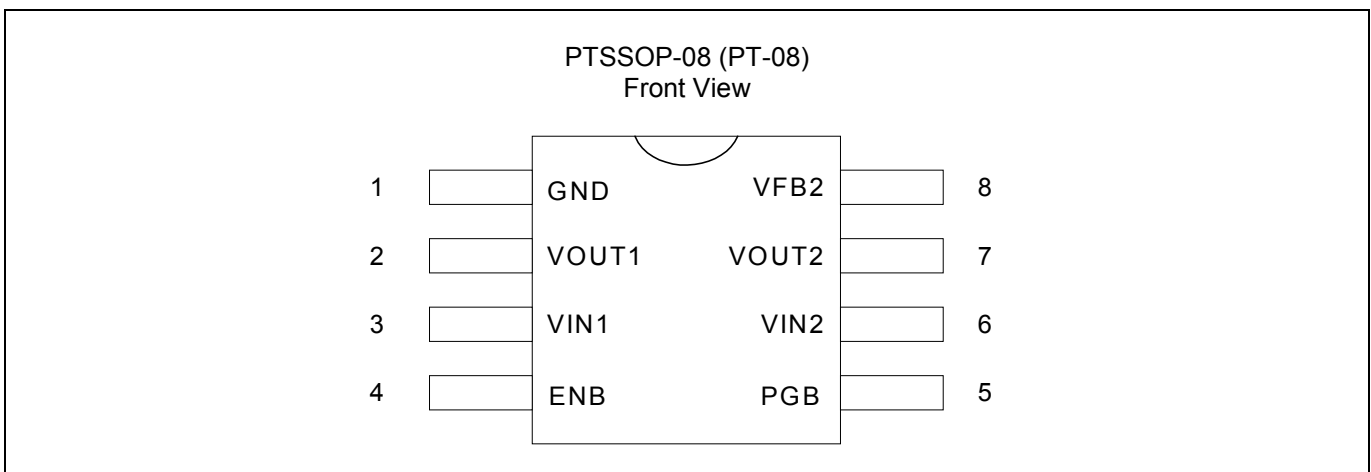

TYPICAL APPLICATION

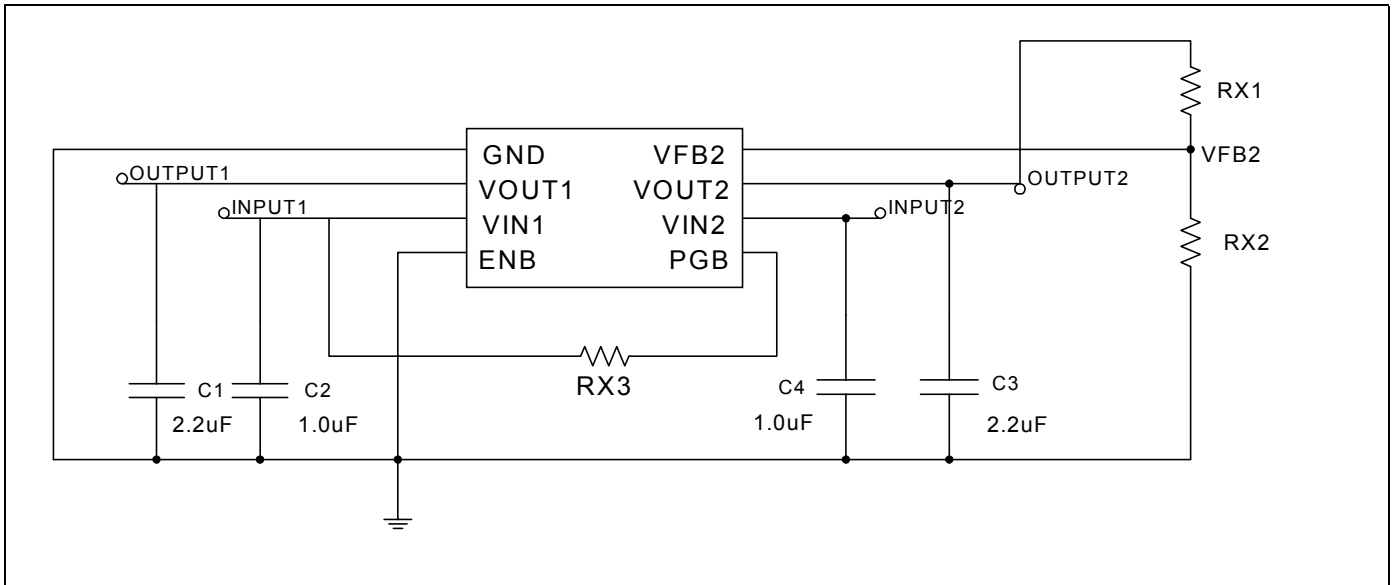

BLOCK DIAGRAM

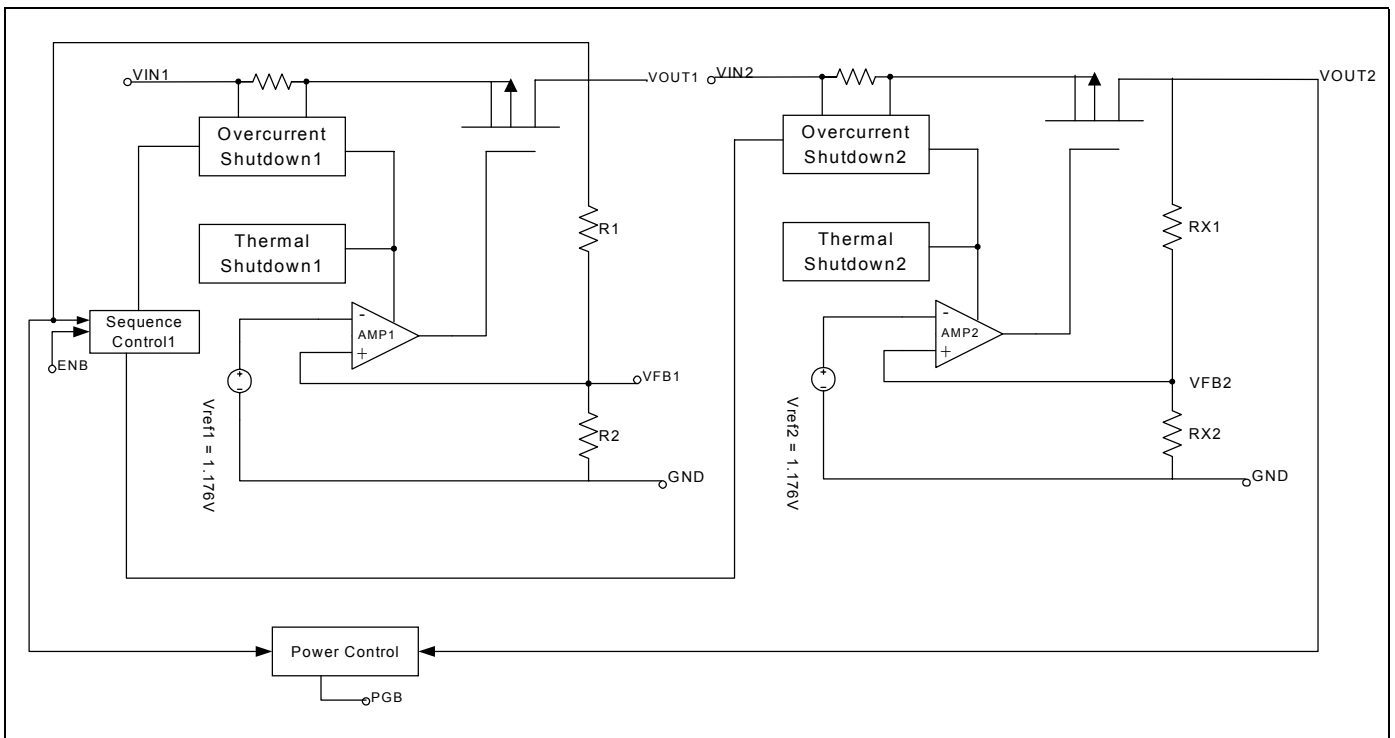

PIN DESCRIPTION

Pin Number	Symbol	Description
1	GND	Master & slave LDO ground
2	VOUT1	Master LDO1 output voltage
3	VIN1	Master LDO1 input voltage
4	ENB	Master LDO1 enable
5	PGB	Dual LDO power good signal
6	VIN2	Slave LDO2 input voltage
7	VOUT2	Slave LDO2 output voltage
8	VFB2	Slave LDO2 feedback signal

ORDERING INFORMATION

Part Number	Output Voltages	Temperature Range	Package
CM2730KIT	2.5V & Adjustable	-40°C ~ +85°C	PTSSOP-08 (PT-08)
CM2730SIT	3.3V & Adjustable	-40°C ~ +85°C	PTSSOP-08 (PT-08)

Note: For other pre-set output voltage requirements of fixed LDO1, please contact Champion Sales office.

ABSOLUTE MAXIMUM RATINGS

Input Voltage +7V
Output Current $P_D / (V_{IN} - V_o)$
Output Voltage GND-0.3V to $V_{IN}+0.3V$
ESD Classification B

OPERATING RATINGS

Ambient Temperature Range (T_A) -40°C to +85°C
Junction Temperature Range -40°C to +125°C
 $V_{IN1} - V_{IN2} < 0.8V$

THERMAL INFORMATION

Parameter	Maximum	Unit
Thermal Resistance (θ_{jc})		°C/W
Thermal Resistance (θ_{ja})		°C/W
Internal Power Dissipation (P_D)($\Delta T = 100^\circ C$)		mW
Maximum Junction Temperature	150	°C
Maximum Lead Temperature (10 Sec)	300	°C

*With Junction sink capable of twice times of θ_{jc}

Caution: Stress above the listed absolute rating may cause permanent damage to the device.

ELECTRICAL CHARACTERISTICS

$T_A = +25^\circ\text{C}$; unless otherwise noted

	Parameter	Test Conditions	CM2730			Unit
			Min.	Typ.	Max.	
Master LDO1	Input Voltage 1		Note 1		7	V
	Output Voltage 1 Accuracy	$I_{O1} = 1\text{mA to } 300\text{mA}$	-1.5		1.5	%
	Output Current 1	$V_{OUT1} > 1.2\text{V}$	300			mA
	Current Limit 1	$V_{OUT1} > 1.2\text{V}$	300	450		mA
	Short Circuit Current 1	$V_{OUT1} < 0.95\text{V}$		150		mA
	Quiescent Current 1	$V_{IN1}=5\text{V, No Load}$	27	30	35	μA
	Ground Pin Current	$V_{IN1}=5\text{V, } I_{O1} = 1\text{mA to } 300\text{mA}$		30	35	μA
	Line Regulation 1	$I_{OUT1}=5\text{mA, } V_{IN1}=V_{OUT1}+1 \text{ to } V_{OUT1}+2, 2.0\text{V}<V_{OUT1}<=3.0\text{V}$	-0.15	0.03	0.15	%
			-0.3	0.06	0.3	%
	Load Regulation 1	$I_{O1}=1\text{mA to } 300\text{mA}$		0.2	1	%
	Dropout Voltage 1	$I_{O1}=300\text{mA, } V_{OUT1}=V_{OUT}-2.0\%$		300		mV
	Power Supply Rejection 1	$I_O = 100\text{mA}$ $C_O=2.2\mu\text{F ceramic}$	$f=1\text{kHz}$		60	dB
			$f=10\text{kHz}$		60	
			$f=100\text{kHz}$		50	
	Over Temperature Shutdown 1			150		$^\circ\text{C}$
	Over Temperature Hysteresis			30		$^\circ\text{C}$
Output Voltage Temp. Coeff. 1			25		ppm/ $^\circ\text{C}$	
Output Noise 1	$f=10\text{Hz to } 100\text{kHz}$ $I_O = 10\text{mA}$	$C_O=2.2\mu\text{F}$		30	μVrms	
		$C_O=100\mu\text{F}$		20		
Slave LDO2	Input Voltage 2		Note 1		7	V
	Output Voltage 2 Accuracy	$I_{O2} = 1\text{mA to } 300\text{mA}$	-1.5		1.5	%
	Output Current 2	$V_{OUT2} > 1.2\text{V}$	300			mA
	Current Limit 2	$V_{OUT2} > 1.2\text{V}$	300	450		mA
	Short Circuit Current 2	$V_{OUT2} < 0.95\text{V}$		150		mA
	Quiescent Current 2	$V_{IN2}=5\text{V, No Load}$		30	35	μA
	Line Regulation 2	$I_{OUT2}=5\text{mA, } V_{IN2}=V_{OUT2}+1 \text{ to } V_{OUT2}+2, V_{OUT2}<=2.0$	-0.1	0.02	0.1	%
			-0.15	0.03	0.15	%
			-0.3	0.06	0.3	%
	Load Regulation 2	$I_{O2}=1\text{mA to } 300\text{mA}$		0.20	1	%
	Dropout Voltage 2	$I_{O2}=300\text{mA, } V_{OUT2}=V_{OUT2}-2.0\%, V_{OUT2}>=2.5\text{V}$		300		mV
		$I_{O2}=300\text{mA, } V_{OUT2}=V_{OUT2}-2.0\%, V_{OUT2}<2.5\text{V}$		800		mV
	Power Supply Rejection 2	$I_O = 100\text{mA}$ $C_O=2.2\mu\text{F ceramic}$	$f=1\text{kHz}$		60	dB
			$f=10\text{kHz}$		60	
			$f=100\text{kHz}$		50	
	Over Temperature Shutdown 2			150		$^\circ\text{C}$
Over Temperature Hysteresis			30		$^\circ\text{C}$	
Output Voltage Temp. Coeff. 2			25		ppm/ $^\circ\text{C}$	
Output Noise 2	$f=10\text{Hz to } 100\text{kHz}$ $I_O = 10\text{mA}$	$C_O=2.2\mu\text{F}$		30	μVrms	
		$C_O=100\mu\text{F}$		20		
Shutdown Current	$V_{IN1}>V_{IN1(MIN)}, V_{IN2}>V_{IN2(MIN)}, ENB = V_{IN1}$		2.0		μA	

ELECTRICAL CHARACTERISTICS (CONTI.)

$T_A = +25^\circ\text{C}$; unless otherwise noted

	Parameter	Test Conditions	CM2730			Unit
			Min.	Typ.	Max.	
PGB (Note2)		$V_{IN1} > V_{IN1(MIN)}$, $V_{IN2} > V_{IN2(MIN)}$, $ENB = GND$, $V_{OUT1} > 0.95V_{OUT1}$, $V_{OUT2} > 0.95V_{OUT2}$,			0.1	V
		$V_{IN1} > V_{IN1(MIN)}$, $V_{IN2} > V_{IN2(MIN)}$, $ENB = GND$, $V_{OUT1} < 0.78V_{OUT1}$, or $V_{OUT2} < 0.78V_{OUT2}$		V_{IN1}		V
LDO2 Turn on Threshold Voltage (V_{O1})		$ENB = 0$, $V_{IN1} > V_{IN1(MIN)}$, $V_{IN2} > V_{IN2(MIN)}$		$0.95V_{OUT1}$		
LDO2 Turn off Threshold Voltage (V_{O1})		$ENB = 0$, $V_{IN1} > V_{IN1(MIN)}$, $V_{IN2} > V_{IN2(MIN)}$		$0.78V_{OUT1}$		
ENB Input Threshold	V_{SH}	$V_{IN1} = 2.6V$ to $7V$		$V_{IN1}/2 + 0.8$		V
	V_{SL}	$V_{IN1} = 2.6V$ to $7V$		$V_{IN1}/2 - 0.8$		V

Note 1. $V_{IN(MIN)} = V_{OUT} + \text{Dropout Voltage}$

Note 2: Dual LDO contains 2 LDO, one is fix output voltage 2.5V or 3.3V (2 versions), which is master LDO1, the other is adjustable output voltage, which is slave LDO2. At normal operation condition, master LDO1 turns on first, and then slave LDO2 turns on as master LDO1 output voltage reaches to 95% spec. V_{OUT1} . Slave LDO2 will turn off as master output decreases to 78% spec. V_{OUT1} .

DETAILED DESCRIPTION

The CM2730 family of CMOS regulators provide a preset output voltage LDO (master LDO1), and one adjustable output voltage LDO (slave LDO2) in which each contains p-channel pass transistor, voltage reference, error amplifier, over-current protection, thermal shutdown, and short circuit protection.

CM2730 has a power sequence. When master LDO1's output voltage, which is preset value in design, reaches to its 95~96% nominal output value, internal logic circuits begin to enable the slave LDO2 function which is adjustable output voltage. When both LDO output voltage values are larger than 95% of their nominal output voltage values, the PGB will go low.

The P-channel pass transistor receives data from the error amplifier, over-current shutdown, short output protection, and thermal protection circuits. During normal operation, the error amplifier compares the output voltage to a precision reference. Over-current and Thermal shutdown circuits become active when the junction temperature exceeds 150°C , or the current exceeds 300mA. During thermal shutdown, the output voltage remains low. Normal operation is restored when the junction temperature drops below 120°C .

The CM2730 switches from voltage mode to current mode when the load exceeds the rated output current. This prevents over-stress. The CM2730 also incorporates current fold-back to reduce power dissipation when the output is short-circuited. This feature becomes active when the output drops below 0.95V, and reduces the current flow by 65%. Full current is restored when the voltage exceeds 0.95V.

EXTERNAL CAPACITOR

The CM2730 is stable with output capacitors to ground of 2.2 μF or greater. It can keep stable even with higher or poor ESR capacitors. A capacitor is recommended between the input and ground to stabilize each input voltage. The input capacitor should be larger than 0.1 μF to have a beneficial effect. All capacitors should be placed in close proximity to the pins. A "quiet" ground termination is desirable.

TYPICAL ELECTRICAL CHARACTERISTICS

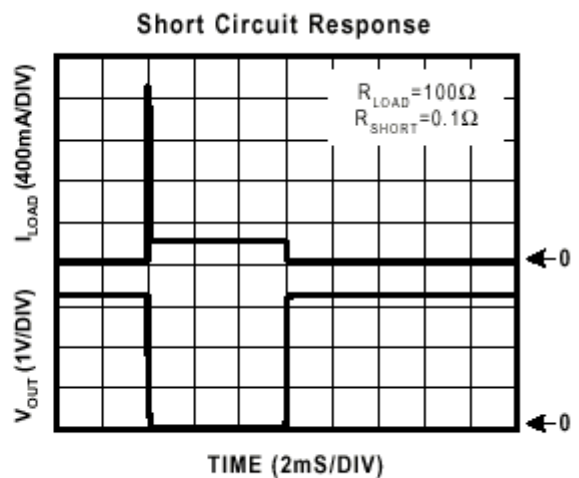
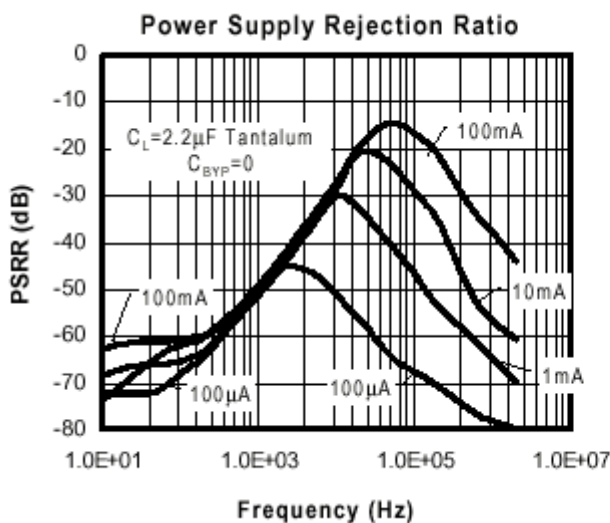
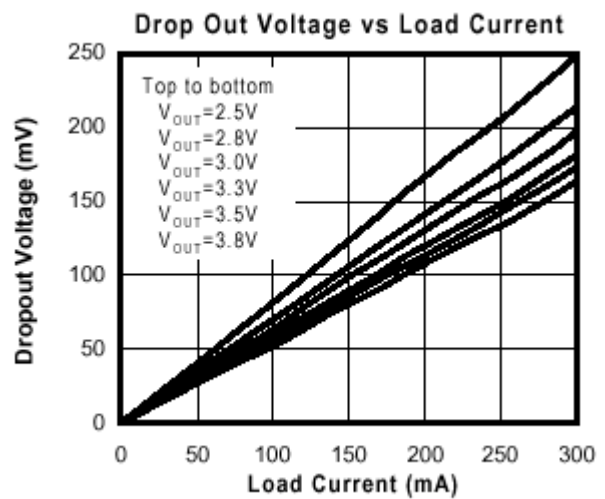
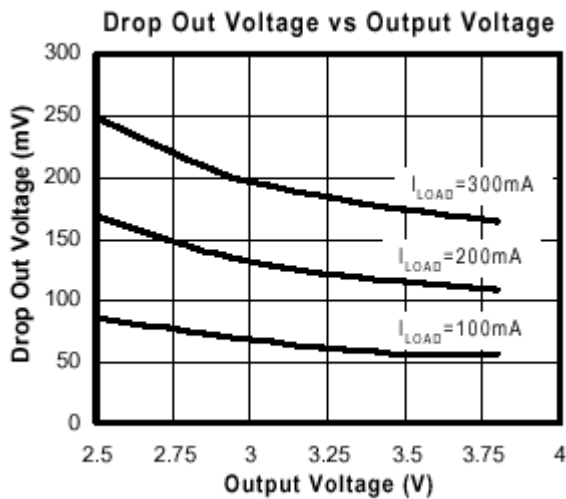
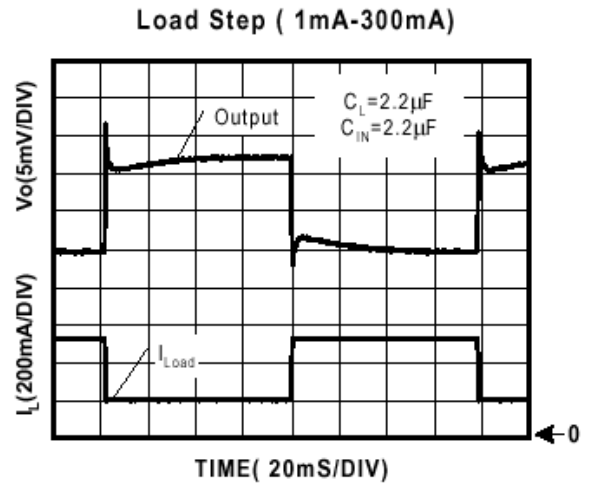
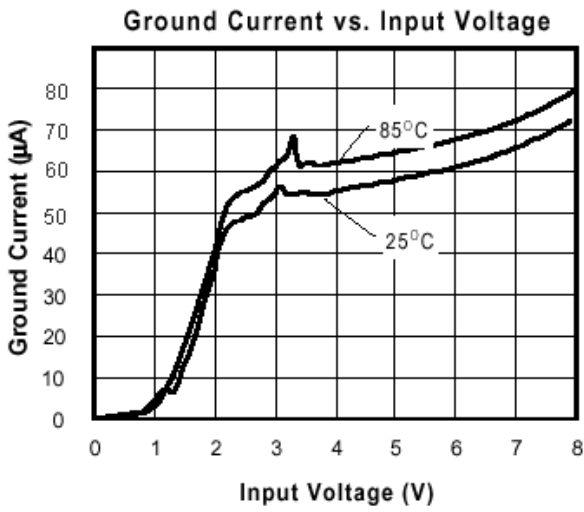

Overtemperature Shutdown

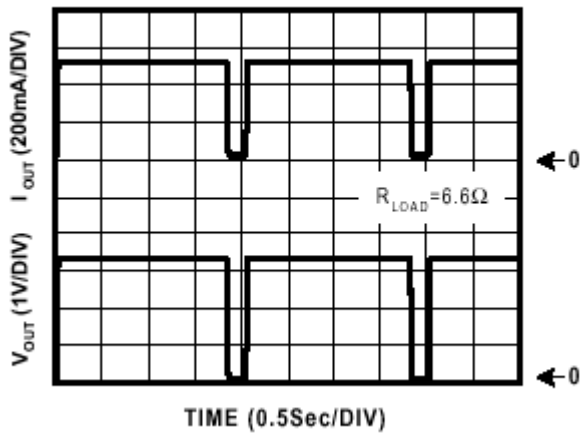

Current Limit Response

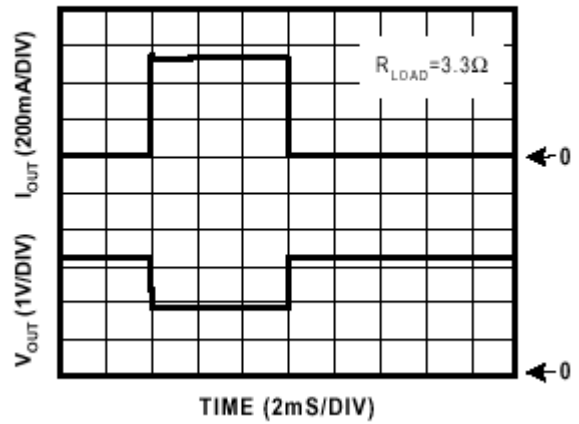

Noise Measurement

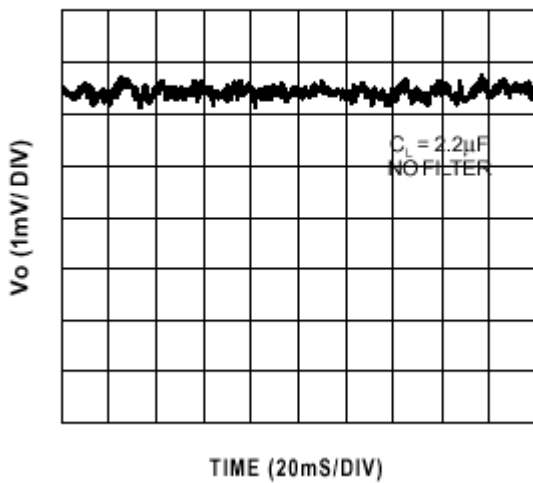

Transient Line Response

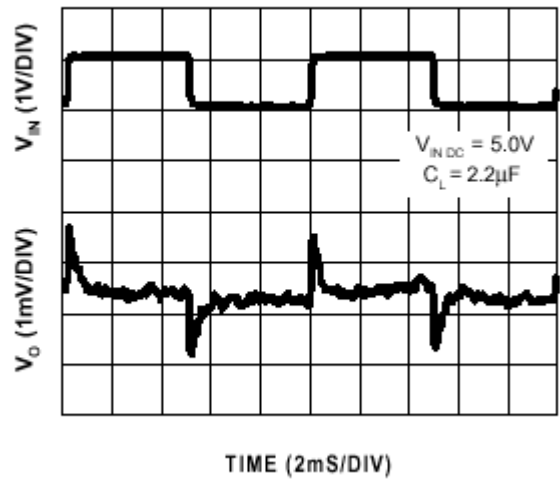

Chip ENB Transient Response

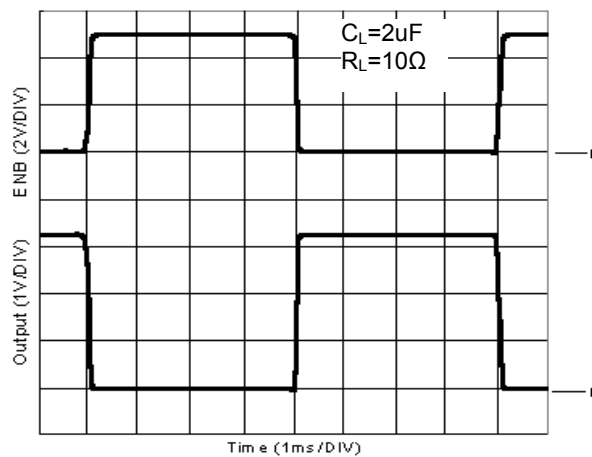

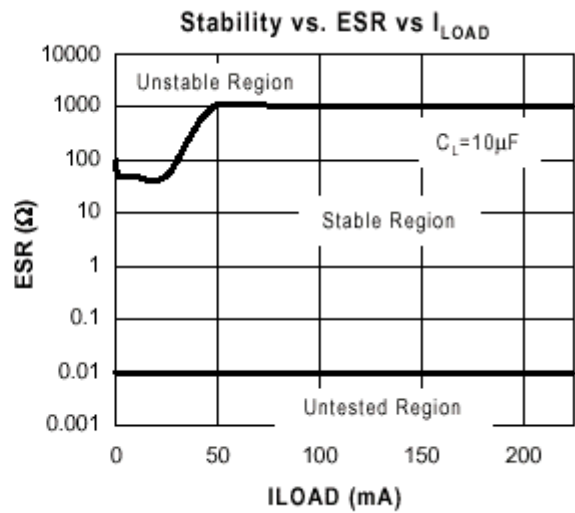
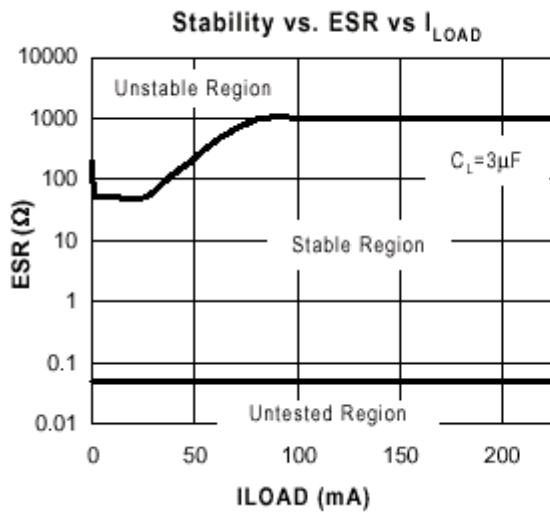
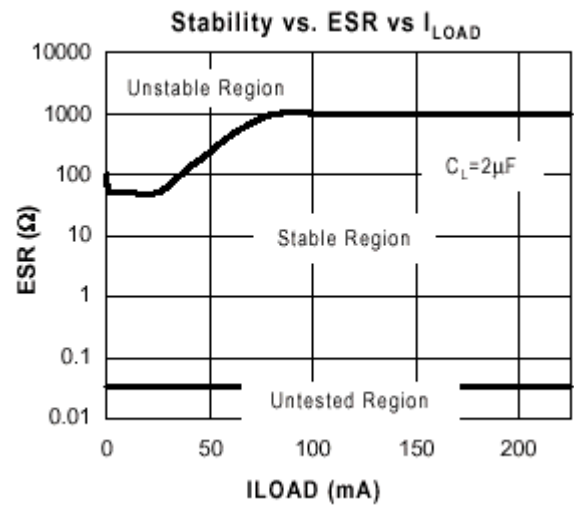
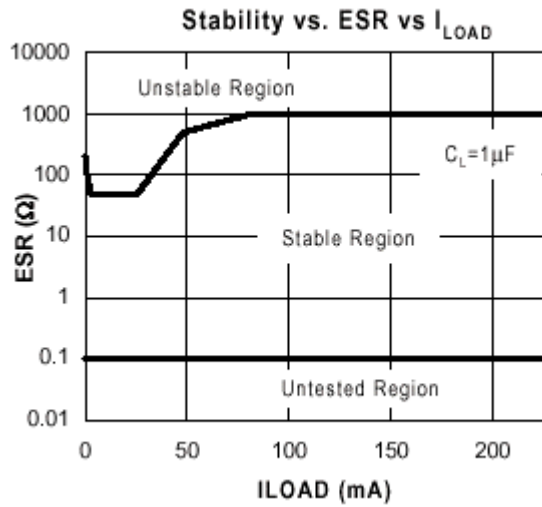

PACKAGE DIMENSION

8-PIN PTSSOP (PT08)

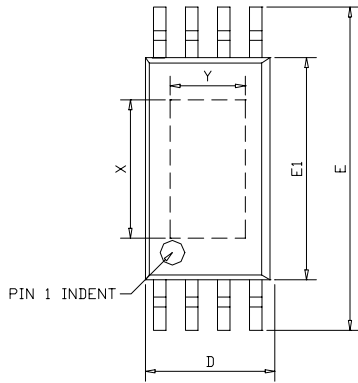

SYMBOLS	DIMENSIONS IN MILLIMETERS			DIMENSIONS IN INCHS		
	MIN	NOM	MAX	MIN	NOM	MAX
A1	0.05	---	0.15	0.002	---	0.006
A2	---	1.00	1.05	---	0.039	0.041
b	0.25	---	0.30	0.010	---	0.012
C	---	0.127	---	---	0.005	---
D	2.90	3.05	3.10	0.114	0.120	0.122
E	6.20	6.40	6.60	0.244	0.252	0.260
E1	4.30	---	4.50	0.169	---	0.177
e	---	0.65	---	---	0.026	---
L	0.50	---	0.70	0.020	---	0.028
θ	0°	---	8°	0°	---	8°

EXPOSED PAD DIMENSION : (mm)
PAD SIZE: X=2.8; Y=1.524

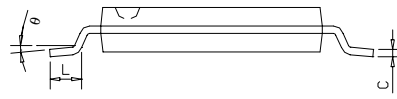
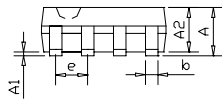

IMPORTANT NOTICE

Champion Microelectronic Corporation (CMC) reserves the right to make changes to its products or to discontinue any integrated circuit product or service without notice, and advises its customers to obtain the latest version of relevant information to verify, before placing orders, that the information being relied on is current.

A few applications using integrated circuit products may involve potential risks of death, personal injury, or severe property or environmental damage. CMC integrated circuit products are not designed, intended, authorized, or warranted to be suitable for use in life-support applications, devices or systems or other critical applications. Use of CMC products in such applications is understood to be fully at the risk of the customer. In order to minimize risks associated with the customer's applications, the customer should provide adequate design and operating safeguards.

HsinChu Headquarter

5F, No. 11, Park Avenue II,
Science-Based Industrial Park,
HsinChu City, Taiwan
TEL: +886-3-567 9979
FAX: +886-3-567 9909

Sales & Marketing

11F, No. 306-3, SEC. 1, Ta Tung Road,
Hsichih, Taipei Hsien 221, Taiwan
TEL: +886-2-8692 1591
FAX: +886-2-8692 1596
