

Automotive Body Power Management LSI



Voltage Tracker

BD3925FP-C, BD3925HFP-C

No.11039EBT06

●Description

BD3925FP-C and BD3925HFP-C are voltage trackers for automotive use which feature high withstand-voltage to 50V. They offer the output current loading to 500mA while limiting the quiescent current to 45 μ A (typ.), so that they suit to apply for systems which are permanently connected to the car battery and requiring low-current-consumption. The offset is ± 15 mV (for 5V output, 6V < Vcc < 36V, 5mA < Io < 200mA). They integrate folded-type of over-current protection to minimize heat dissipation while accidentally shorted, thus lead to most robust power-supply design under the harsh automotive environment.

●Features

- 1) Ultra-low quiescent current: 45 μ A (TYP.)
- 2) Low-saturation voltage type P-channel DMOS output transistors
- 3) Low offset voltage: ± 15 mV(for 5V output, 6V < Vcc < 36V, 5mA < Io < 200mA)
- 4) Vcc power supply voltage = 50 V
- 5) Integrated over-current protection circuit and thermal shutdown circuit
- 6) TO252-5/HRP5 Package

●Applications

Onboard vehicle devices (body-control, car stereos, satellite navigation systems, etc.)

●Product line

Part No.	Package
BD3925FP-C	TO252-5
BD3925HFP-C	HRP5

●Absolute maximum ratings (Ta=25°C)

Parameter	Symbol	Limit	Unit
Supply Voltage	Vcc	50 ^{※1}	V
Switch Supply Voltage	Vsw	50	V
VADJ Terminal Supply Voltage	VADJ	28	V
Vo Terminal Voltage	Vout	28	V
Output Current	Io	500	mA
Power Dissipation	Pd	1.3 (TO252-5) ^{※2}	W
		1.6 (HRP5) ^{※3}	
Operating Temperature Range	Topr	-40 ~ +125	°C
Storage Temperature Range	Tstg	-55 ~ +150	°C
Maximum Junction Temperature	Tjmax	150	°C

※1 Not to exceed Pd and ASO.

※2 TO252-5: Reduced by 10.4 mW/°C over 25 °C, when mount on a glass epoxy board : 70 mm \times 70 mm \times 1.6 mm.

※3 HRP5: Reduced by 12.8 mW/°C over 25 °C, when mount on a glass epoxy board : 70 mm \times 70 mm \times 1.6 mm).

NOTE: This product is not designed for protection against radioactive rays.

●Operating Conditions

Parameter	Symbol	Min.	Max.	Unit
Supply Voltage	V _{CC}	4.5 ※ ⁴	36.0	V
Input Voltage ※ ⁵	V _{ADJ}	2.5	14	V
Output Current	I _o	—	500	mA

※⁴ Please consider that the Output voltage would be dropped (Dropout voltage) according to the output current.

※⁵ Not to exceed V_{CC} - 0.5V.

NOTE: This product is not designed for protection against radioactive rays.

●Electrical Characteristics (Unless otherwise specified, T_a=-40 ~ 125°C, V_{CC}=13.2 V, SW=3V, ADJ=5V)

Parameter	Symbol	Min.	Typ.	Max.	Unit	Conditions
Shut Down Current	I _{shut}	—	—	10	μA	SW=GND
Bias Current	I _b	—	45	90	μA	I _o =0mA
Offset Voltage	ΔV _o	-15	—	15	mV	6V<V _{CC} <36V, 5mA<I _o <200mA
Output Current	I _o	0.5	—	—	A	
Dropout Voltage	ΔV _d	—	0.25	0.48	V	V _{CC} =5V, V _{ADJ} =5V, I _o =200mA
Ripple Rejection	R.R.	45	55	—	dB	f=120Hz, e _{in} =1V _{rms} , I _o =100mA
Switch Threshold Voltage H	SWH	2.0	—	—	V	ACTIVE MODE
Switch Threshold Voltage L	SWL	—	—	0.5	V	OFF MODE
Switch Bias Current	SWI	—	22	60	μA	SW=5V
ADJ Bias Voltage	ADJI	—	5	12	μA	ADJ=5V

●Reference Data (BD3925FP-C)

Unless otherwise specified, $V_{CC}=13.2V$, $ADJ=5V$, $SW=3V$, $T_a=25^\circ C$

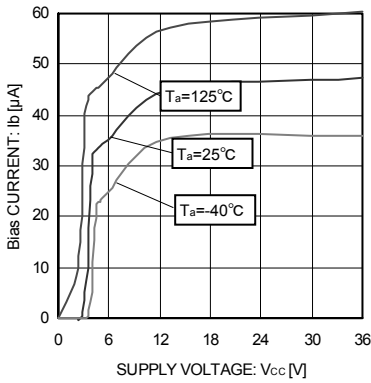

Fig.1 Bias current

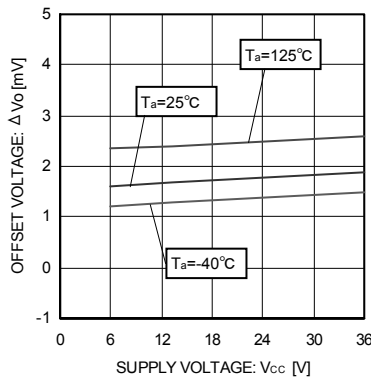

Fig.2 Output voltage vs power supply voltage 1 ($I_o=5mA$)

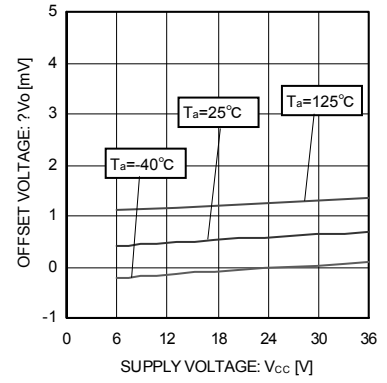

Fig.3 Output voltage vs power supply voltage 2 ($I_o=200mA$)

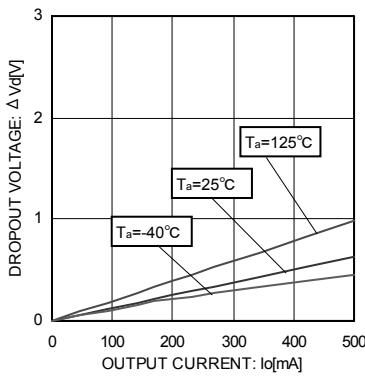

Fig.4 Dropout voltage

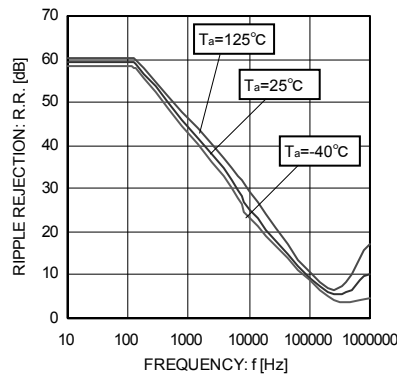

Fig.5 Ripple rejection

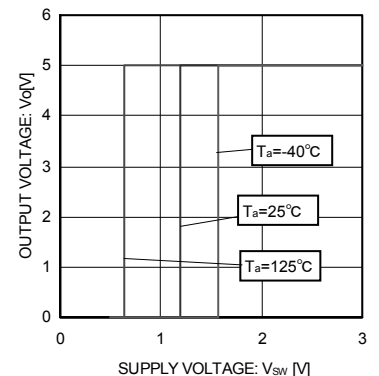

Fig.6 Output voltage vs SW input voltage

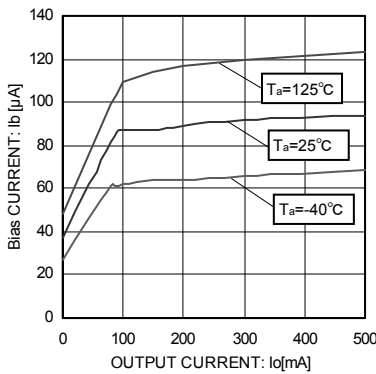

Fig.7 Bias current classified by load

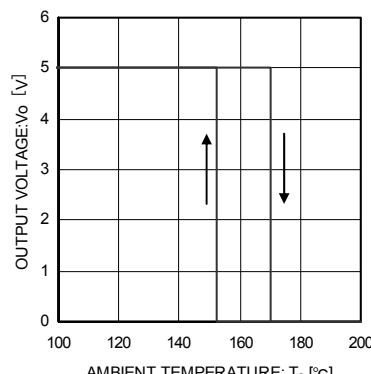

Fig.8. Thermal shutdown circuit

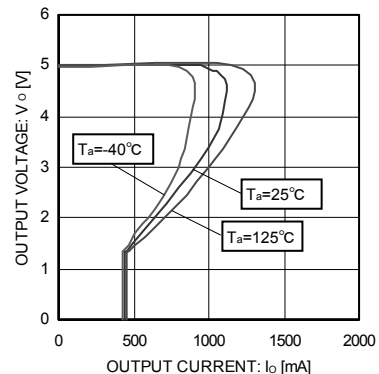

Fig.9 Output voltage vs load

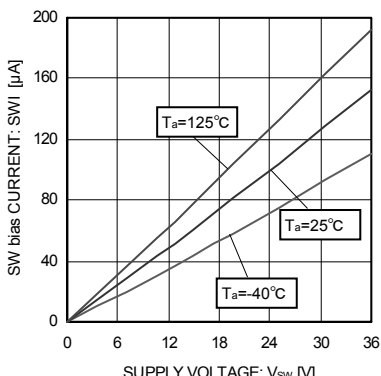

Fig.10 SW bias current

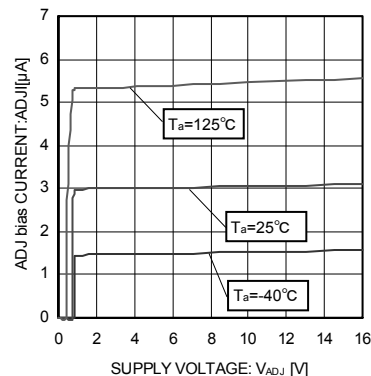

Fig.11 ADJ bias current

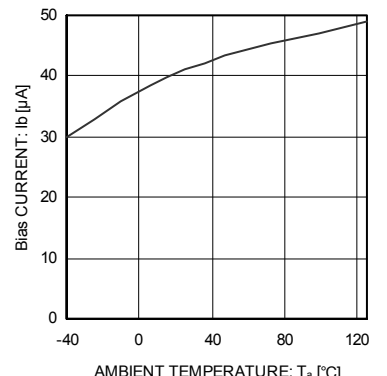

Fig.12 Bias current vs temperature

●Block Diagram

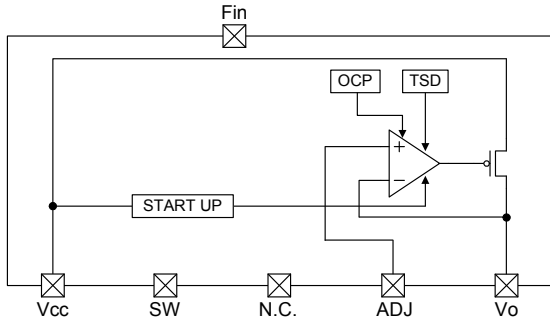

Fig.13 (FP)

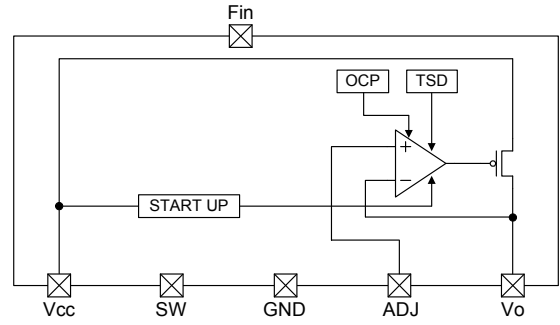

Fig.14 (HFP)

TO252-5

Pin No.	Pin Name	Function
1	Vcc	Power supply pin
2	SW	Vo on/off function pin
3	N.C.	No Connection
4	ADJ	Input voltage
5	Vo	Output Voltage
Fin	GND	Grand

HRP5

Pin No.	Pin Name	Function
1	Vcc	Power supply pin
2	SW	Vo on/off function pin
3	GND	Grand
4	ADJ	Input voltage
5	Vo	Output Voltage
Fin	GND	Grand

●Top View (Package dimension)

TO252-5

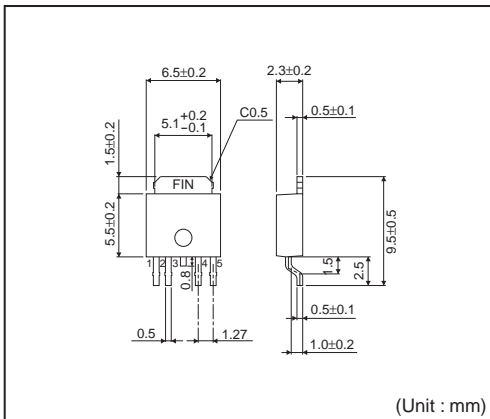

HRP5

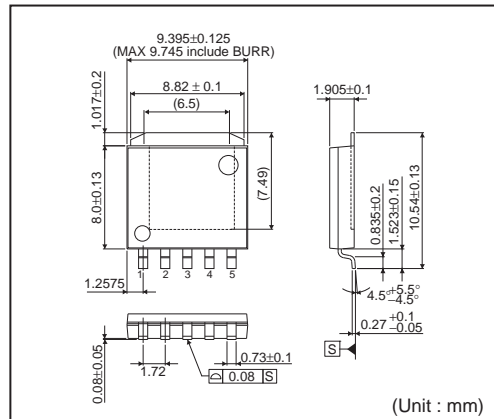

●I/O equivalence circuit (All resistance values are typical.)

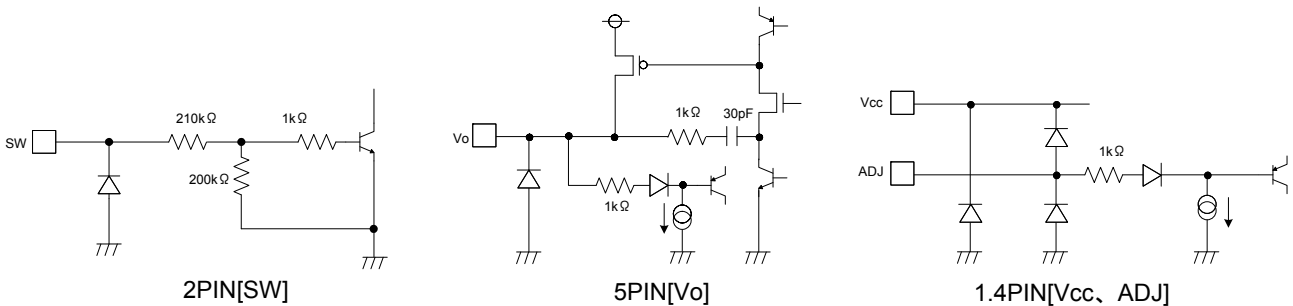

● Thermal Dissipation Curve

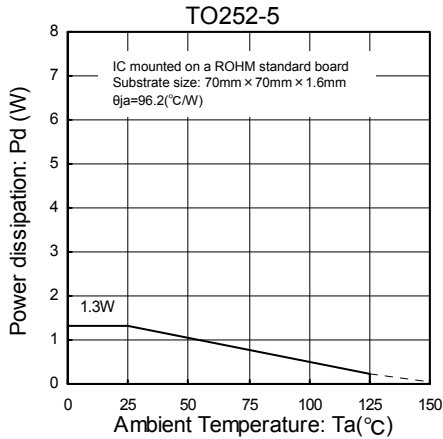

Fig. 15

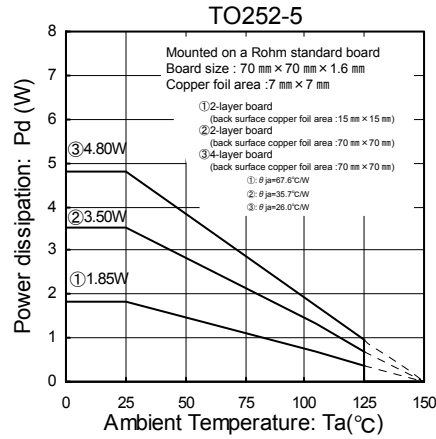

Fig. 16

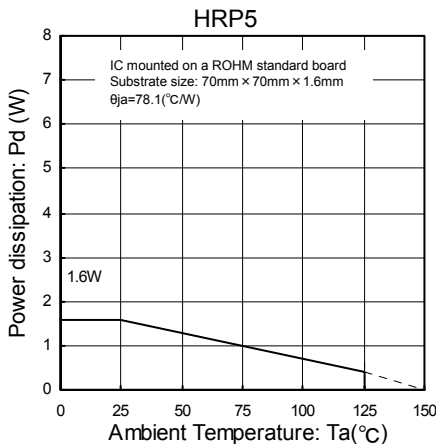

Fig. 17

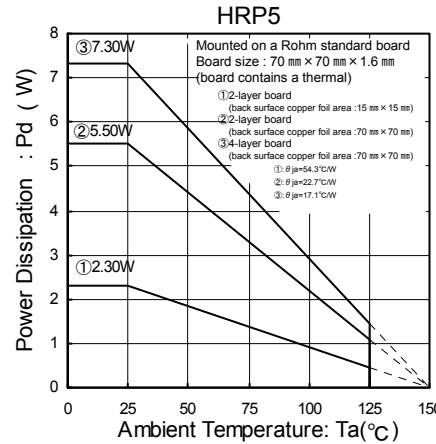

Fig. 18

Refer to the heat mitigation characteristics illustrated in Figs. 15 ~ 18 when using the IC in an environment where $T_a \geq 25^\circ\text{C}$. The characteristics of the IC are greatly influenced by the operating temperature. If the temperature is in excess of the maximum junction temperature T_{jmax} , the elements of the IC may be deteriorated or damaged. It is necessary to give sufficient consideration to the heat of the IC in view of two points, i.e., the protection of the IC from instantaneous damage and the maintenance of the reliability of the IC in long-time operation.

In order to protect the IC from thermal destruction, it is necessary to operate the IC not in excess of the maximum junction temperature T_{jmax} . Fig. 15,16 illustrates the power dissipation/heat mitigation characteristics for the TO252 package. Operate the IC within the power dissipation P_d . The following method is used to calculate the power consumption P_c (W).

$$P_c = (V_{cc} - V_o) \times I_o + V_{cc} \times I_b$$

Power dissipation $P_d \geq P_c$

V_{cc} : Input voltage
 V_o : Output voltage
 I_o : Load current
 I_b : Total supply current

The load current I_o is obtained to operate the IC within the power dissipation.

$$I_o \leq \frac{P_d - V_{cc} \times I_b}{V_{cc} - V_o} \quad \text{(Please refer to Fig.7 and Fig.12 for } I_b \text{.)}$$

The maximum load current I_{omax} for the applied voltage V_{cc} can be calculated during the thermal design process.

Example) BD3925FP-C $V_{cc} = 12\text{V}$ and $V_o = 5\text{V}$ (ADJ=5) at $T_a = 85^\circ\text{C}$

$$I_o \leq \frac{0.624 - 12 \times I_b}{12 - 5} \quad \left(\begin{array}{l} \theta_{ja} = 96.2^\circ\text{C/W} \rightarrow -10.4\text{mAW}/^\circ\text{C} \\ 25^\circ\text{C} = 1.3\text{W} \rightarrow 85^\circ\text{C} = 0.624\text{W} \end{array} \right)$$

$$I_o \leq 89\text{mA} \quad (I_b = 100\mu\text{A})$$

Make a thermal calculation in consideration of the above so that the whole operating temperature range will be within the power dissipation.

The power consumption P_c of the IC in the event of shorting (i.e., if the V_o and GND pins are shorted) will be obtained from the following equation.

$$P_c = V_{cc} \times (I_{cc} + I_{short}) \quad I_{short} = \text{Short current} \quad \text{(Please refer to Fig.9 for } I_{short} \text{.)}$$

● Pin Settings / Precautions

1. Vcc pins
Insert capacitors with a capacitance of $0.33\mu\text{F}$ to $1000\mu\text{F}$ between the Vcc and GND pins.
The capacitance varies with the application. Be sure to design the capacitance with a sufficient margin.
2. Output pin
It is necessary to place capacitors between each output pin and GND to prevent oscillation on the output. Usable capacitance values range from $4.7\mu\text{F}$ to $1000\mu\text{F}$. Ceramic capacitors can be used as long as their ESR value is low enough to prevent oscillation. Abrupt fluctuations in input voltage and load conditions may affect the output voltage. Output capacitance values should be determined only through sufficient testing of the actual application.

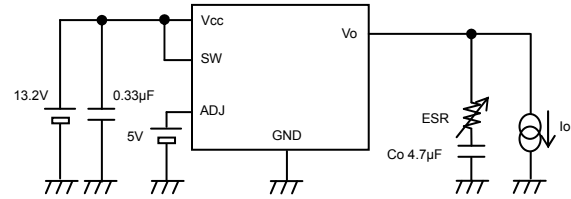
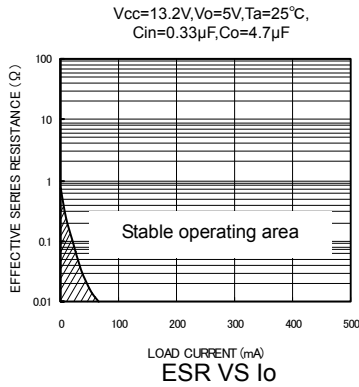

※ Pin Settings / Precautions 2 Measurement circuit

●Notes for use

1. Absolute maximum ratings
Use of the IC in excess of absolute maximum ratings such as the applied voltage or operating temperature range may result in IC damage. Assumptions should not be made regarding the state of the IC (short mode or open mode) when such damage is suffered. A physical safety measure such as a fuse should be implemented when use of the IC in a special mode where the absolute maximum ratings may be exceeded is anticipated.
2. GND potential
Ensure a minimum GND pin potential in all operating conditions.
3. Thermal design
The Power dissipation indicated on this specification is the value without heat sink. Use a thermal design that allows for a sufficient margin by attaching with heat sink in light of the power dissipation (Pd) in actual operating conditions.
4. Pin short and mistake mounting
Use caution when orienting and positioning the IC for mounting on printed circuit boards. Improper mounting may result in damage to the IC. Shorts between output pins and the power supply and GND pins caused by the presence of a foreign object may result in damage to the IC. Ensure a minimum GND pin potential in all operating conditions.
5. Actions in strong magnetic field
Keep in mind that the IC may malfunction in strong magnetic fields
6. Testing on application boards
When testing the IC on an application board, connecting a capacitor to a pin with low impedance subjects the IC to stress. Always discharge capacitors after each process or step. Always turn the IC's power supply off before connecting it to or removing it from a jig or fixture during the inspection process. Ground the IC during assembly steps as an antistatic measure, and use similar caution when transporting or storing the IC
7. Ground patterns
When using both small signal and large current GND patterns, it is recommended to isolate the two ground patterns, placing a single ground point at the application's reference point so that the pattern wiring resistance and voltage variations caused by large currents do not cause variations in the small signal ground voltage. Be careful not to change the GND wiring pattern of any external parts, either.
8. Applications or inspection processes where the potentials of the Vcc pin and other pins may be reversed from their normal states may cause damage to the IC's internal circuitry or elements. Use an output pin capacitance of 470 μ F or lower in case Vcc is shorted with the GND pin while the external capacitor is charged. It is recommended to insert a diode for preventing back current flow in series with Vcc or by-pass diodes between Vcc and each pin.

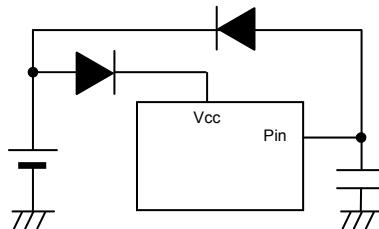

9. SW Pin, ADJ Pin
Do not apply the voltage to SW pin and ADJ pin when the Vcc is not applied.
And when the Vcc is applied, the voltage of SW pin and ADJ pin must not exceed Vcc.
10. Thermal shutdown circuit (TSD)
This IC incorporates a built-in TSD circuit for the protection from thermal destruction. The IC should be used within the specified power dissipation range. However, in the event that the IC continues to be operated in excess of its power dissipation limits, the attendant rise in the junction temperature (T_j) will trigger the TSD circuit to turn off all output power elements (175°C:Typ). The circuit automatically resets once the junction temperature (T_j) drops (150°C:Typ). Operation of the TSD circuit presumes that the IC's absolute maximum ratings have been exceeded. Application designs should never make use of the TSD circuit.
11. Overcurrent protection circuit (OCP)
The IC incorporates a built-in overcurrent protection circuit that operates according to the output current capacity. This circuit serves to protect the IC from damage when the load is shorted. The protection circuit is designed to limit current flow by not latching in the event of a large and instantaneous current flow originating from a large capacitor or other component. This protection circuits is effective in preventing damage due to sudden and unexpected accidents. However, the IC should not be used in applications characterized by the continuous operation or transitioning of the protection circuits. At the time of thermal designing, keep in mind that the current capacity has negative characteristics to temperatures.

12. About positive surge voltage

To protect against a surge voltage that exceeds 50V between Vcc and GND please insert a power zener diode between Vcc terminal and GND.

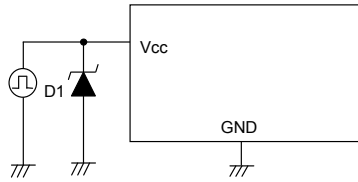

13. About negative surge voltage

To protect against a negative surge voltage, please insert a Schottky diode between the Vcc terminal and GND.

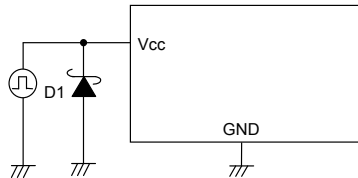

14. For an infinitesimal fluctuations of output voltage

At the use of the application that infinitesimal fluctuations of output voltage caused by some factors (e.g. disturbance noise, input voltage fluctuations, load fluctuations, etc.), please take enough measures to avoid some influence (e.g. insert the filter, etc.).

15. We recommend using Diode for protection purpose when the temperature so output voltage is off.

This is to prevent against large loads of impedance or reverse current during initial stages or output off stage

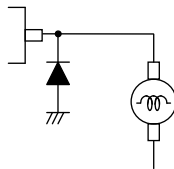

16. This monolithic IC contains P+ isolation and P substrate layers between adjacent elements in order to keep them isolated. P/N junctions are formed at the intersection of these P layers with the N layers of other elements to create a variety of parasitic elements. For example, when the resistors and transistors are connected to the pins as shown in the following figure,

- The P/N junction functions as a parasitic diode when GND > Pin A for the resistor or GND > Pin B for the transistor (NPN).
- Similarly, when GND > Pin B for the transistor (NPN), the parasitic diode described above combines with the N layer of other adjacent elements to operate as a parasitic NPN transistor.

The formation of parasitic elements as a result of the relationships of the potentials of different pins is an inevitable result of the IC's architecture. The operation of parasitic elements can cause interference with circuit operation as well as IC malfunction and damage. For these reasons, it is necessary to use caution so that the IC is not used in a way that will trigger the operation of parasitic elements, such as by the application of voltages lower than the GND (P substrate) voltage to input pins. Keep in mind that the IC may malfunction in strong magnetic fields.,

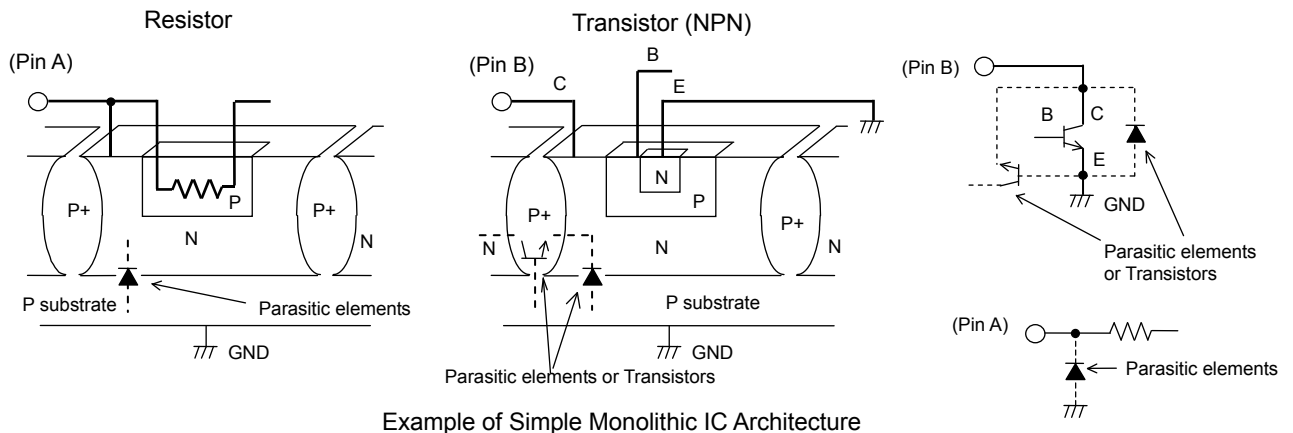

●Part Number Selection

B	D	3	9	2	5	H	F	P	-	C	T	R
Part No.		Part No.				Package HFP :HRP5 FP :TO252-5			Packaging and forming specification TR: Embossed tape and reel (HRP5) E2: Embossed tape and reel (TO252-5)			

HRP5

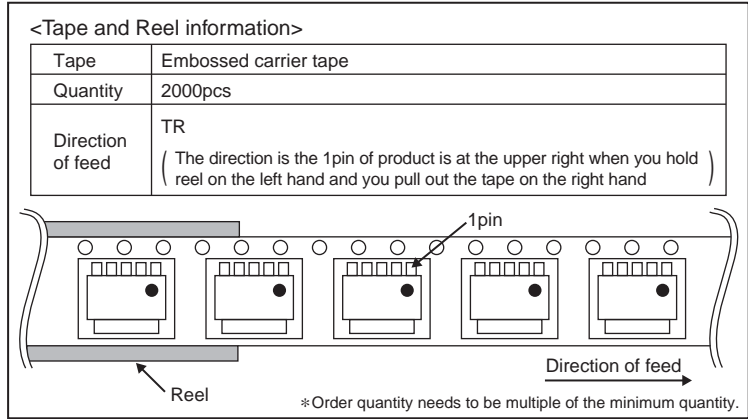
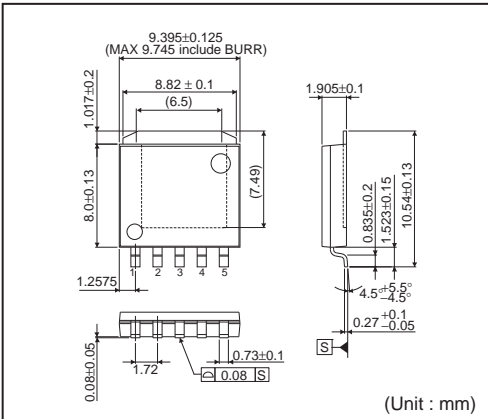

TO252-5

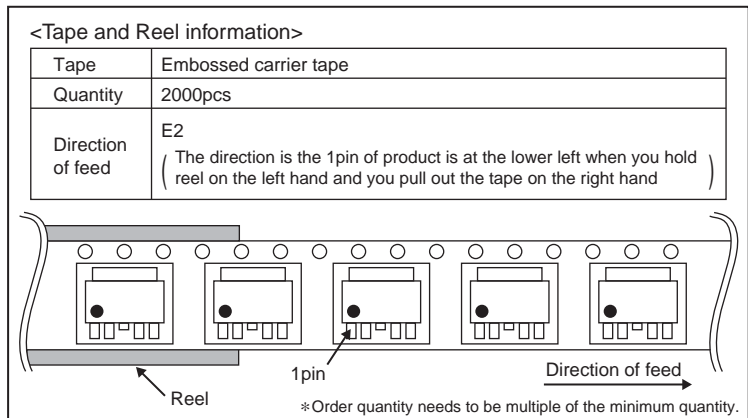
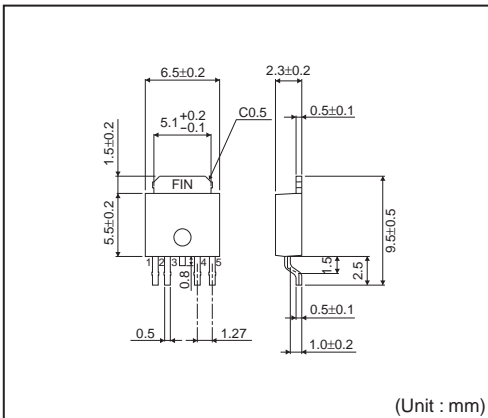

Notes

No copying or reproduction of this document, in part or in whole, is permitted without the consent of ROHM Co.,Ltd.

The content specified herein is subject to change for improvement without notice.

The content specified herein is for the purpose of introducing ROHM's products (hereinafter "Products"). If you wish to use any such Product, please be sure to refer to the specifications, which can be obtained from ROHM upon request.

Examples of application circuits, circuit constants and any other information contained herein illustrate the standard usage and operations of the Products. The peripheral conditions must be taken into account when designing circuits for mass production.

Great care was taken in ensuring the accuracy of the information specified in this document. However, should you incur any damage arising from any inaccuracy or misprint of such information, ROHM shall bear no responsibility for such damage.

The technical information specified herein is intended only to show the typical functions of and examples of application circuits for the Products. ROHM does not grant you, explicitly or implicitly, any license to use or exercise intellectual property or other rights held by ROHM and other parties. ROHM shall bear no responsibility whatsoever for any dispute arising from the use of such technical information.

The Products specified in this document are intended to be used with general-use electronic equipment or devices (such as audio visual equipment, office-automation equipment, communication devices, electronic appliances and amusement devices).

The Products specified in this document are not designed to be radiation tolerant.

While ROHM always makes efforts to enhance the quality and reliability of its Products, a Product may fail or malfunction for a variety of reasons.

Please be sure to implement in your equipment using the Products safety measures to guard against the possibility of physical injury, fire or any other damage caused in the event of the failure of any Product, such as derating, redundancy, fire control and fail-safe designs. ROHM shall bear no responsibility whatsoever for your use of any Product outside of the prescribed scope or not in accordance with the instruction manual.

The Products are not designed or manufactured to be used with any equipment, device or system which requires an extremely high level of reliability the failure or malfunction of which may result in a direct threat to human life or create a risk of human injury (such as a medical instrument, transportation equipment, aerospace machinery, nuclear-reactor controller, fuel-controller or other safety device). ROHM shall bear no responsibility in any way for use of any of the Products for the above special purposes. If a Product is intended to be used for any such special purpose, please contact a ROHM sales representative before purchasing.

If you intend to export or ship overseas any Product or technology specified herein that may be controlled under the Foreign Exchange and the Foreign Trade Law, you will be required to obtain a license or permit under the Law.



Thank you for your accessing to ROHM product informations.
More detail product informations and catalogs are available, please contact us.

ROHM Customer Support System

<http://www.rohm.com/contact/>