

MAXIM

1- to 3-Cell, High-Current, Low-Noise, Step-Up DC-DC Converters with Linear Regulator

General Description

The MAX1705/MAX1706 are high-efficiency, low-noise, step-up DC-DC converters with an auxiliary linear-regulator output. These devices are intended for use in battery-powered wireless applications. They use a synchronous rectifier pulse-width-modulation (PWM) boost topology to generate 2.5V to 5.5V outputs from battery inputs, such as 1 to 3 NiCd/NiMH cells or 1 Li-Ion cell. The MAX1705 has an internal 1A N-channel MOSFET switch. The MAX1706 has a 0.5A switch. Both devices also have a built-in low-dropout linear regulator that delivers up to 200mA.

With an internal synchronous rectifier, the MAX1705/MAX1706 deliver 5% better efficiency than similar non-synchronous converters. They also feature a pulse-frequency-modulation (PFM) standby mode to improve efficiency at light loads, and a 1 μ A shutdown mode. An efficiency-enhancing track mode reduces the step-up DC-DC converter output to 300mV above the linear-regulator output.

Both devices come in a 16-pin QSOP package, which occupies the same space as an 8-pin SO. Other features include two shutdown-control inputs for push-on/push-off control, and an uncommitted comparator for use as a voltage monitor.

Applications

Digital Cordless Phones	PCS Phones
Personal Communicators	Wireless Handsets
Palmtop Computers	Two-Way Pagers
Hand-Held Instruments	

Pin Configuration

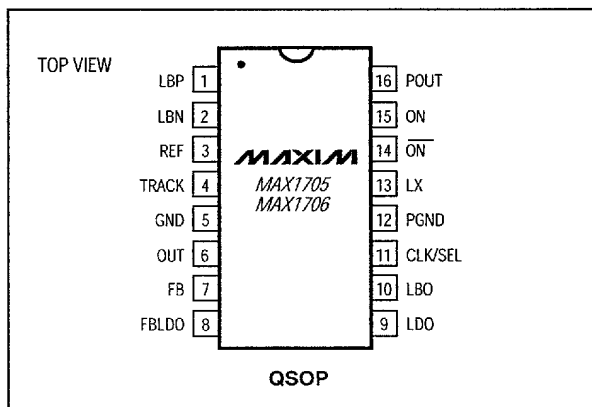

Features

- ◆ Up to 96% Efficiency
- ◆ 1.1V_{IN} Guaranteed Start-Up
- ◆ Up to 850mA Output (MAX1705)
- ◆ Step-Up Output (2.5V to 5.5V adjustable)
- ◆ Linear Regulator (1.25V to 5.0V adjustable)
- ◆ PWM/PFM Synchronous-Rectified Topology
- ◆ 300kHz PWM Mode or Synchronizable
- ◆ 1 μ A Shutdown Mode
- ◆ Voltage Monitor
- ◆ Pushbutton On/Off Control

Ordering Information

PART	TEMP. RANGE	PIN-PACKAGE
MAX1705C/D	0°C to +70°C	Dice*
MAX1705EEE	-40°C to +85°C	16 QSOP
MAX1706C/D	0°C to +70°C	Dice*
MAX1706EEE	-40°C to +85°C	16 QSOP

*Dice are tested at $T_A = +25^\circ\text{C}$, DC parameters only.

Typical Operating Circuit

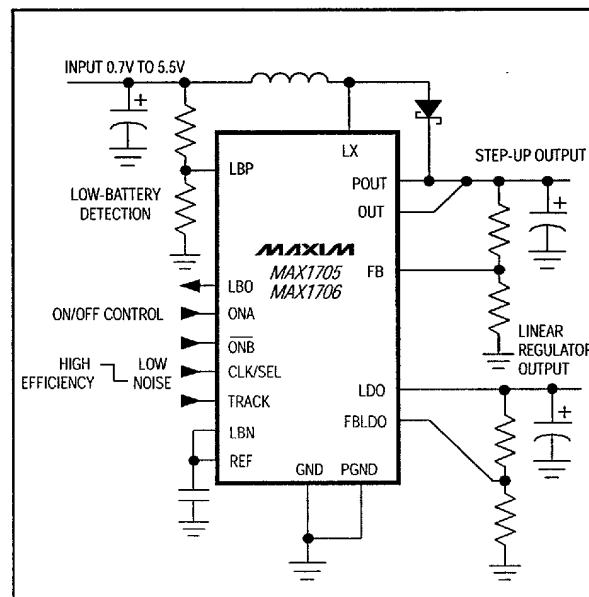
**MAXIM**

Maxim Integrated Products 1

For free samples & the latest literature: <http://www.maxim-ic.com>, or phone 1-800-998-8800

■ 5876651 0016037 04T ■

MAX1705/MAX1706

1- to 3-Cell, High-Current, Low-Noise, Step-Up DC-DC Converters with Linear Regulator

ABSOLUTE MAXIMUM RATINGS

ONA, \overline{ONB} , FBLDO, OUT, POUT to GND.....	-0.3V to 6V	Continuous Power Dissipation ($T_A = +70^\circ\text{C}$)	
PGND to GND.....	$\pm 0.3\text{V}$	QSOP (derate 8.70mW/ $^\circ\text{C}$ above $+70^\circ\text{C}$).....	696mW
POUT to OUT.....	$\pm 0.3\text{V}$	Operating Temperature Range	-40°C to $+85^\circ\text{C}$
LX to PGND	-0.3V to $(V_{\text{POUT}} + 0.3\text{V})$	Junction Temperature	$+150^\circ\text{C}$
CLK/SEL, REF, FB, TRACK, LDO, LBN, LBP, LBO to GND.....	-0.3V to $(V_{\text{OUT}} + 0.3\text{V})$	Storage Temperature Range	-65°C to $+160^\circ\text{C}$
LDO Short Circuit	Continuous	Lead Temperature (soldering, 10sec)	$+300^\circ\text{C}$

Stresses beyond those listed under "Absolute Maximum Ratings" may cause permanent damage to the device. These are stress ratings only, and functional operation of the device at these or any other conditions beyond those indicated in the operational sections of the specifications is not implied. Exposure to absolute maximum rating conditions for extended periods may affect device reliability.

ELECTRICAL CHARACTERISTICS

($V_{\text{OUT}} = V_{\text{POUT}} = V_{\text{LBP}} = 3.6\text{V}$, CLK/SEL = FB = LBN = LBO = ONA = \overline{ONB} = TRACK = GND, REF = open (bypassed with 0.22 μF), LX = open, $T_A = 0^\circ\text{C}$ to $+85^\circ\text{C}$, unless otherwise noted. Typical values are at $T_A = +25^\circ\text{C}$.)

PARAMETER	SYMBOL	CONDITIONS	MIN	TYP	MAX	UNITS
DC-DC CONVERTER						
Minimum Start-Up Voltage		$T_A = +25^\circ\text{C}$, $I_{\text{LOAD}} < 1\text{mA}$, Figure 2		0.9	1.1	V
Minimum Operating Battery Voltage		(Note 1)		0.7		V
FB Regulation Voltage		CLK/SEL = OUT	1.219	1.233	1.247	V
FB Input Current		$V_{\text{FB}} = 1.5\text{V}$		0.01	50	nA
OUT Adjust Range			2.5		5.5	V
Load Regulation		MAX1705, $0\text{A} \leq I_{\text{LX}} \leq 0.5\text{A}$; MAX1706, $0\text{A} \leq I_{\text{LX}} \leq 0.25\text{A}$; CLK/SEL = OUT		0.65	1.25	%
OUT Voltage in Track Mode		TRACK = $V_{\text{LDO}} > 2.3\text{V}$	$V_{\text{LDO}} + 0.2$	$V_{\text{LDO}} + 0.3$	$V_{\text{LDO}} + 0.4$	V
Frequency in Start-Up Mode	f_{LX}	$V_{\text{POUT}} = V_{\text{OUT}} = 1.5\text{V}$	40	150	300	kHz
Start-Up to Normal Mode Transition Voltage		(Note 2)	2.00	2.15	2.30	V
Supply Current in Shutdown	I_{OUT}	ONA = GND, \overline{ONB} = OUT, measure I_{OUT}		1	20	μA
Supply Current in Low-Power Mode	I_{OUT}	CLK/SEL = GND, $V_{\text{FB}} = V_{\text{FBLDO}} = 1.5\text{V}$, no load		100	190	μA
Supply Current in Low-Noise Mode	I_{OUT}	CLK/SEL = OUT		180	360	μA
		FB = GND (LX switching)		2.1		mA
REFERENCE						
Reference Output Voltage		$I_{\text{REF}} = 0\mu\text{A}$	1.238	1.250	1.262	V
Reference Load Regulation		$-1\mu\text{A} < I_{\text{REF}} < 50\mu\text{A}$		4	15	mV
Reference Supply Regulation		$2.5\text{V} < V_{\text{OUT}} < 5.5\text{V}$		0.2	5	mV

1- to 3-Cell, High-Current, Low-Noise, Step-Up DC-DC Converters with Linear Regulator

MAX1705/MAX1706

ELECTRICAL CHARACTERISTICS (continued)

($V_{OUT} = V_{POUT} = V_{LBP} = 3.6V$, $CLK/SEL = FB = LBN = LBO = ONA = \overline{ONB} = TRACK = GND$, $REF = open$ (bypassed with $0.22\mu F$), $LX = open$, $T_A = 0^\circ C$ to $+85^\circ C$, unless otherwise noted. Typical values are at $T_A = +25^\circ C$.)

PARAMETER	SYMBOL	CONDITIONS	MIN	TYP	MAX	UNITS	
DC-DC SWITCHES							
POUT Leakage Current		$V_{LX} = 0V$, $V_{\overline{ONB}} = V_{OUT} = 5.5V$		0.1	20	μA	
LX Leakage Current		$V_{LX} = 0V$, $V_{\overline{ONB}} = V_{OUT} = 5.5V$		0.1	20	μA	
Switch On-Resistance		N-channel, $I_{LX} = 100mA$	CLK/SEL = GND	0.23	0.45	Ω	
			CLK/SEL = OUT	0.16	0.28		
		P-channel, $I_{LX} = 100mA$		0.27	0.50		
N-Channel MOSFET Current Limit	I_{LIM}	CLK/SEL = OUT	MAX1705	1000	1280	1550	mA
			MAX1706	550	750	950	
		CLK/SEL = GND	MAX1705	250	435	550	
			MAX1706	250	435	550	
P-Channel Synchronous-Rectifier Turn-Off Current		CLK/SEL = GND	20	70	120	mA	
LINEAR REGULATOR							
FBLDO Regulation Voltage		FBLDO = LDO, $I_{LOAD} = 1mA$	1.238	1.250	1.262	V	
FBLDO Input Current		$V_{FBLDO} = 1.5V$		0.01	50	nA	
LDO Adjust Range			1.25		5.0	V	
Short-Circuit Current Limit		FBLDO = GND	220	300	500	mA	
Dropout Resistance		$V_{FBLDO} = 1V$, $I_{LDO} = 200mA$		0.5	1.2	Ω	
Load Regulation		$10\mu A < I_{LDO} < 200mA$, FBLDO = LDO		0.4	1.2	%	
Line Regulation		$2.5V < V_{OUT} < 5.5V$, FBLDO = LDO, $I_{LDO} = 1mA$		0.1	0.5	%	
AC Power-Supply Rejection		$f = 300kHz$		38		dB	
Thermal Shutdown		Hysteresis approximately $10^\circ C$		155		$^\circ C$	
LOW-BATTERY COMPARATOR							
LBN, LBP Offset		LBP falling	-5		5	mV	
LBN, LBP Hysteresis		LBP rising		16		mV	
LBN, LBP Common-Mode Input Range		$V_{LBN} = 0.5V$ and $1.5V$ (at least one input must be within this range)	0.5		1.5	V	
LBN, LBP Input Current		$V_{LBN} = V_{LBP} = 1V$		0.01	50	nA	
LBO Output Low Voltage		$I_{SINK} = 1mA$, $V_{OUT} = 2.5V$, LBP = GND, LBN = OUT			0.4	V	
LBO High Leakage		$V_{LBO} = V_{OUT} = 5V$			1	μA	
CONTROL INPUTS							
Input Low Level		$1.2V < V_{OUT} < 5.5V$, ONA, \overline{ONB} (Note 3)			$0.2V_{OUT}$	V	
		$V_{OUT} = 2.5V$, CLK/SEL, TRACK			$0.2V_{OUT}$		
Input High Level		$1.2V < V_{OUT} < 5.5V$, ONA, \overline{ONB} (Note 3)	$0.8V_{OUT}$			V	
		$V_{OUT} = 5.5V$, CLK/SEL, TRACK	$0.8V_{OUT}$				
Input Leakage Current (CLK/SEL, ONA, \overline{ONB} , TRACK)					1	μA	

MAXIM

3

5876651 0016039 912

1- to 3-Cell, High-Current, Low-Noise, Step-Up DC-DC Converters with Linear Regulator

ELECTRICAL CHARACTERISTICS (continued)

(V_{OUT} = V_{POUT} = V_{LBP} = 3.6V, CLK/SEL = FB = LBN = LBO = ONA = \overline{ONB} = TRACK = GND, REF = open (bypassed with 0.22μF), LX = open, T_A = 0°C to +85°C, unless otherwise noted. Typical values are at T_A = +25°C.)

PARAMETER	SYMBOL	CONDITIONS	MIN	TYP	MAX	UNITS
Internal Oscillator Frequency		CLK/SEL = OUT	260	300	340	kHz
External Oscillator Synchronization Range			200		400	kHz
Oscillator Maximum Duty Cycle			80	86	90	%
Minimum CLK/SEL Pulse				200		ns
Maximum CLK/SEL Rise/Fall Time				100		ns

ELECTRICAL CHARACTERISTICS

(V_{OUT} = V_{POUT} = V_{LBP} = 3.6V, CLK/SEL = FB = LBN = LBO = ONA = \overline{ONB} = TRACK = GND, REF = open (bypassed with 0.22μF), LX = open, T_A = -40°C to +85°C, unless otherwise noted, Note 4.)

PARAMETER	SYMBOL	CONDITIONS	MIN	TYP	MAX	UNITS
DC-DC CONVERTER						
FB Regulation Voltage		CLK/SEL = OUT	1.215		1.251	V
OUT Voltage in Track Mode		TRACK = OUT, V _{LDO} > 2.3V	V _{LDO} + 0.2		V _{LDO} + 0.4	V
Start-Up to Normal Mode Transition Voltage			2.0		2.3	V
Supply Current in Shutdown	I _{OUT}	ONA = 0V, \overline{ONB} = OUT, measure I _{OUT}			20	μA
Supply Current in Low-Power Mode	I _{OUT}	CLK/SEL = 0V, FB = FBLDO = 1.5V, no load			190	μA
Supply Current in Low-Noise Mode	I _{OUT}	CLK/SEL = OUT, V _{FB} = V _{FBLDO} = 1.5V, no load			360	μA
REFERENCE						
Reference Output Voltage		I _{REF} = 0μA	1.235		1.265	V
DC-DC CONVERTER						
Switch On-Resistance		N-channel, I _{LX} = 100mA	CLK/SEL = 0V		0.45	Ω
			CLK/SEL = OUT		0.28	
		P-channel, I _{LX} = 100mA	CLK/SEL = OUT		0.50	
N-Channel MOSFET Current Limit	I _{LIM}	CLK/SEL = OUT	MAX1705	1000	1700	mA
			MAX1706	550	950	
		CLK/SEL = 0V	MAX1705	250	570	
			MAX1706	250	570	
P-Channel Synchronous-Rectifier Turn-Off Current		CLK/SEL = 0V	20		120	mA

1- to 3-Cell, High-Current, Low-Noise, Step-Up DC-DC Converters with Linear Regulator

MAX1705/MAX1706

ELECTRICAL CHARACTERISTICS (continued)

($V_{OUT} = V_{POUT} = V_{LBP} = 3.6V$, $CLK/SEL = FB = LBN = LBO = ONA = \overline{ONB} = TRACK = GND$, $REF = open$ (bypassed with $0.22\mu F$), $LX = open$, $T_A = -40^{\circ}C$ to $+85^{\circ}C$, unless otherwise noted, Note 4.)

PARAMETER	SYMBOL	CONDITIONS	MIN	TYP	MAX	UNITS
LINEAR REGULATOR						
FBLDO Regulation Voltage		FBLDO = LDO, $I_{LOAD} = 1mA$	1.233		1.268	V
FBLDO Input Current		$V_{FBLDO} = 1.5V$		0.01	50	nA
Short-Circuit Current Limit		FBLDO = LDO = GND	220		600	mA
Dropout Resistance		$V_{FBLDO} = 1V$, $I_{LDO} = 200mA$			1.2	Ω
LOW-BATTERY COMPARATOR						
LBN, LBP Offset		LBP falling	-5		5	mV
LBN, LBP Common-Mode Input Range		LBN = 0.5V and 1.5V (at least one input must be within this range)	0.5		1.5	V
LBO High Leakage		LBO = OUT = 5V			1	μA
CONTROL INPUTS						
Input Low Level		$1.2V < V_{OUT} < 5.5V$, ONA, \overline{ONB} (Note 2)			$0.15V_{OUT}$	V
		$V_{OUT} = 2.5V$, CLK/SEL, TRACK			$0.15V_{OUT}$	
Input High Level		$1.2V < V_{OUT} < 5.5V$, ONA, \overline{ONB} (Note 2)	$0.85V_{OUT}$			V
		$V_{OUT} = 5.5V$, CLK/SEL, TRACK	$0.85V_{OUT}$			
Internal Oscillator Frequency		CLK/SEL = OUT	260		340	kHz
External Oscillator Synchronization Range			200		400	kHz

Note 1: Once the output is in regulation, the MAX1705/MAX1706 operate down to a 0.7V input voltage.

Note 2: The device is in start-up mode when V_{OUT} is below this value (see *Low-Voltage Start-Up Oscillator* section).

Note 3: ONA and \overline{ONB} inputs have a hysteresis of approximately $0.15V_{OUT}$.

Note 4: Specifications to $-40^{\circ}C$ to are guaranteed by design, not production tested.

1- to 3-Cell, High-Current, Low-Noise, Step-Up DC-DC Converters with Linear Regulator

Typical Operating Characteristics

(Circuit of Figure 2, $T_A = +25^\circ\text{C}$, unless otherwise noted.)

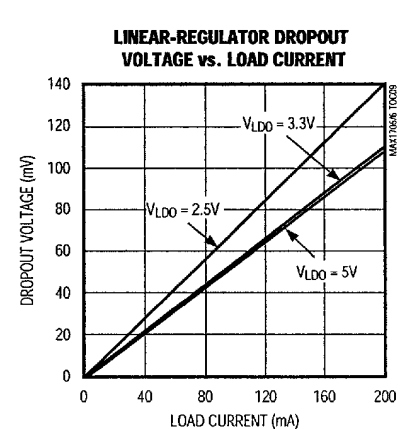
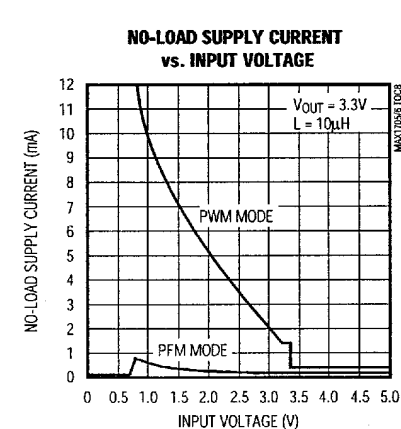
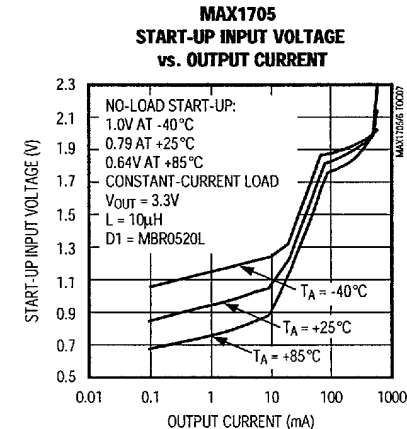
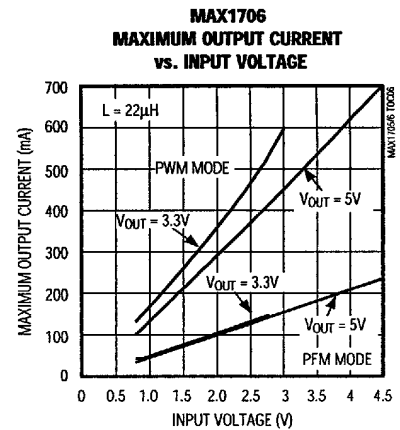
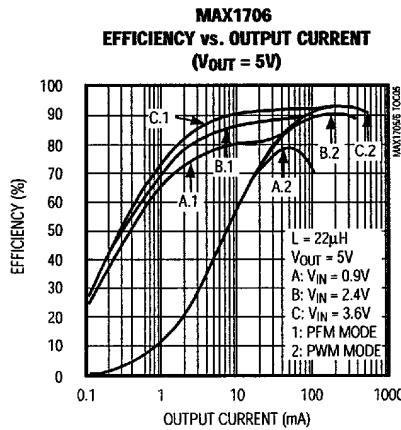
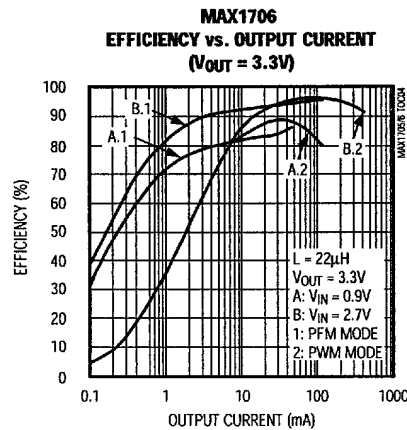
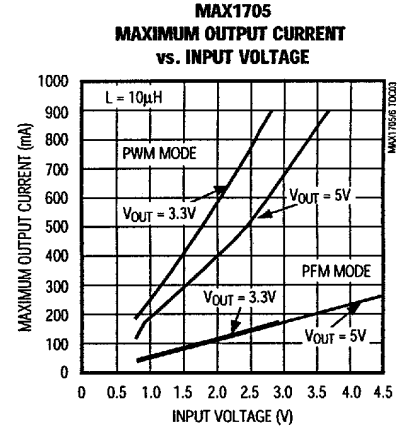
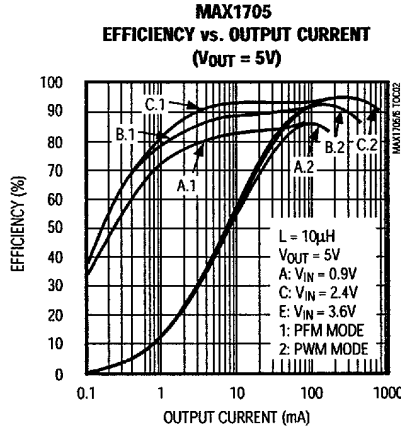
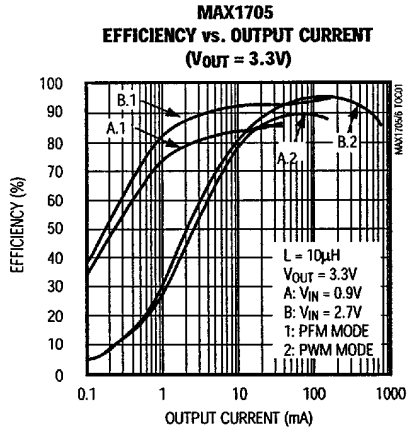

1- to 3-Cell, High-Current, Low-Noise, Step-Up DC-DC Converters with Linear Regulator

Typical Operating Characteristics (continued)

(Circuit of Figure 2, $T_A = +25^\circ\text{C}$, unless otherwise noted.)

MAX1705/MAX1706

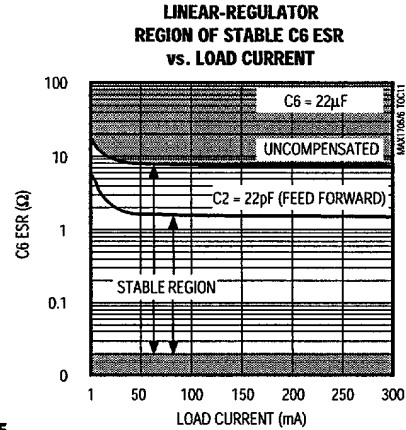
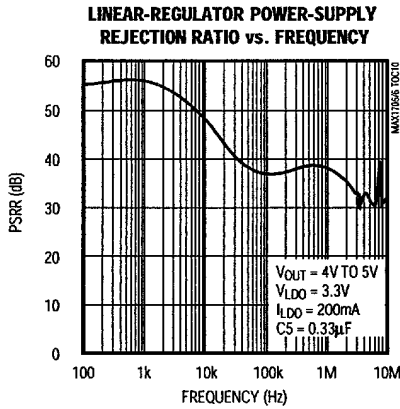

MAX1705 NOISE SPECTRUM AT POUT
($V_{OUT} = 4.5\text{V}$, $V_{IN} = 1.2\text{V}$, 200mA LOAD)

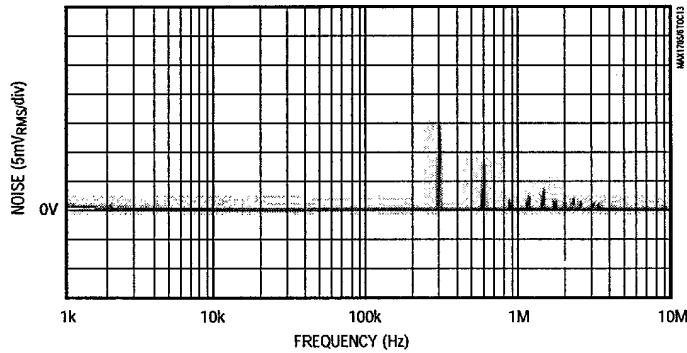

MAX1705 LINEAR-REGULATOR OUTPUT NOISE SPECTRUM
($V_{LDO} = 3.3\text{V}$, $V_{OUT} = 4.5\text{V}$, $V_{IN} = 1.2\text{V}$, $I_{LDO} = 200\text{mA}$)

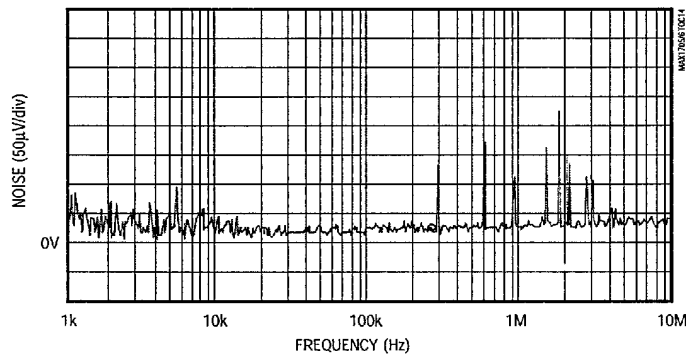

1- to 3-Cell, High-Current, Low-Noise, Step-Up DC-DC Converters with Linear Regulator

Typical Operating Characteristics (continued)

(Circuit of Figure 2, $T_A = +25^\circ\text{C}$, unless otherwise noted.)

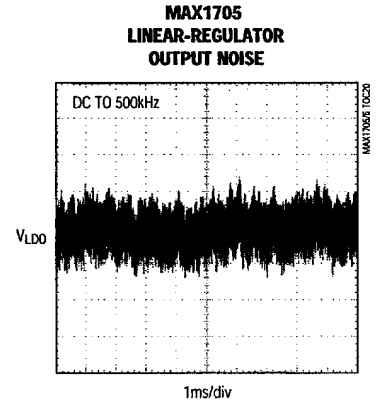
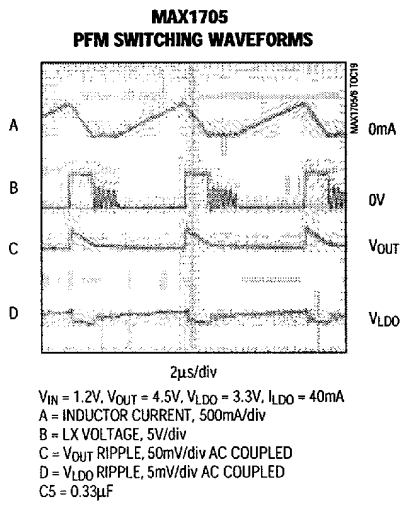
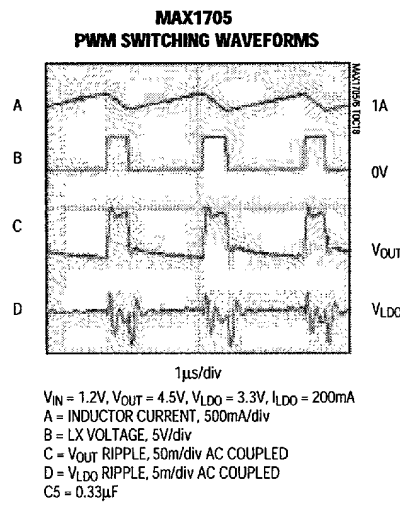
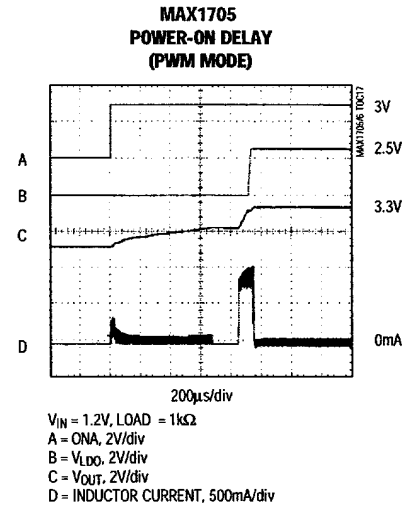
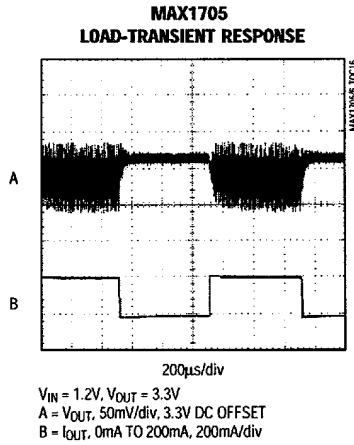
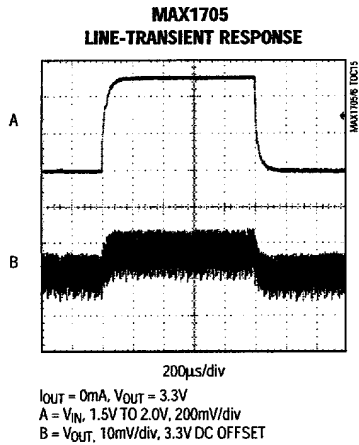

1- to 3-Cell, High-Current, Low-Noise, Step-Up DC-DC Converters with Linear Regulator

Pin Description

MAX1705/MAX1706

PIN	NAME	FUNCTION
1	LBP	Low-Battery Comparator Noninverting Input. Common-mode range is 0.5V to 1.5V.
2	LBN	Low-Battery Comparator Inverting Input. Common-mode range is 0.5V to 1.5V.
3	REF	1.250V Reference Output. Bypass REF with a 0.33 μ F capacitor to GND. REF can source up to 50 μ A.
4	TRACK	Track-Mode Control Input for DC-DC Converter. In track mode, the boost-converter output is sensed at OUT and set 0.3V above LDO to improve efficiency. Set TRACK to OUT for track mode. Connect TRACK to GND for normal operation.
5	GND	Ground
6	OUT	Step-Up Converter Feedback Input, used during track mode. IC power and low-dropout linear-regulator input. Bypass OUT to GND with a 0.1 μ F ceramic capacitor placed as close to the IC as possible.
7	FB	Step-Up DC-DC Converter Feedback Input. Connect FB to a resistor voltage divider between POUT and GND to set the output voltage between 2.5V and 5.5V. FB regulates to 1.233V.
8	FBLDO	Low-Dropout Linear-Regulator Feedback Input. Connect FBLDO to a resistor voltage divider between LDO to GND to set the output voltage from 1.25V to $V_{OUT} - 0.3V$ (5.0V max). FBLDO regulates to 1.250V.
9	LDO	Low-Dropout Linear-Regulator Output. LDO sources up to 200mA. Bypass to GND with a 22 μ F capacitor.
10	LBO	Low-Battery Comparator Output. This open-drain, N-channel output is low when LBP < LBN. Input hysteresis is 16mV.
11	CLK/SEL	Switching-Mode Selection and External-Clock Synchronization Input: <ul style="list-style-type: none"> • CLK/SEL = low: low-power, low-quiescent-current PFM mode. • CLK/SEL = high: low-noise, high-power PWM mode. Switches at a constant frequency (300kHz). Full output power is available. • CLK/SEL = driven with an external clock: low-noise, high-power synchronized PWM mode. Synchronizes to an external clock (from 200kHz to 400kHz). Turning on the DC-DC converter with CLK/SEL = GND also serves as a soft-start function, since peak inductor current is reduced.
12	PGND	Power Ground for the source of the N-channel power MOSFET switch
13	LX	Inductor connection to the drains of the P-channel synchronous rectifier and N-channel switch
14	\overline{ONB}	Off Control Input. When \overline{ONB} = high and ONA = low, the IC is off. Connect \overline{ONB} to GND for normal operation (Table 2).
15	ONA	On Control Input. When ONA = high or \overline{ONB} = low, the IC turns on. Connect ONA to OUT for normal operation (Table 2).
16	POUT	Boost DC-DC Converter Power Output. POUT is the source of the P-channel synchronous-rectifier MOSFET switch. Connect an external Schottky diode from LX to POUT. The output current available from POUT is reduced by the current drawn from the LDO linear-regulator output.

1- to 3-Cell, High-Current, Low-Noise, Step-Up DC-DC Converters with Linear Regulator

Detailed Description

The MAX1705/MAX1706 are designed to supply both power and low-noise circuitry in portable RF and data-acquisition instruments. They combine a linear regulator, step-up switching regulator, N-channel power MOSFET, P-channel synchronous rectifier, precision reference, and low-battery comparator in a single 16-pin QSOP package (Figure 1). The switching DC-DC converter boosts a 1- or 2-cell input to an adjustable output between 2.5V and 5.5V. The internal low-dropout regulator provides linear post-regulation for noise-sensitive circuitry, as well as outputs from 1.25V to 300mV below the switching-regulator output. The MAX1705/MAX1706 start from a low, 1.1V input and remain operational down to 0.7V.

These devices are optimized for use in cellular phones and other applications requiring low noise during full-power operation, as well as low quiescent current for

maximum battery life during standby and shutdown. They feature constant-frequency (300kHz), low-noise pulse-width-modulation (PWM) operation with 300mA or 730mA output capability from one or two cells, respectively, with 3.3V output. A low-quiescent-current standby pulse-frequency-modulation (PFM) mode offers an output up to 60mA and 140 μ A, respectively, and reduces quiescent power consumption to 500 μ W. In shutdown mode, the quiescent current is further reduced to just 1 μ A. Figure 2 shows the standard application circuit for the MAX1705 configured in high-power PWM mode.

Additional features include synchronous rectification for high efficiency and improved battery life, and an uncommitted comparator for low-battery detection. A CLK/SEL input allows frequency synchronization to reduce interference. Dual shutdown controls allow shutdown using a momentary pushbutton switch and micro-processor control.

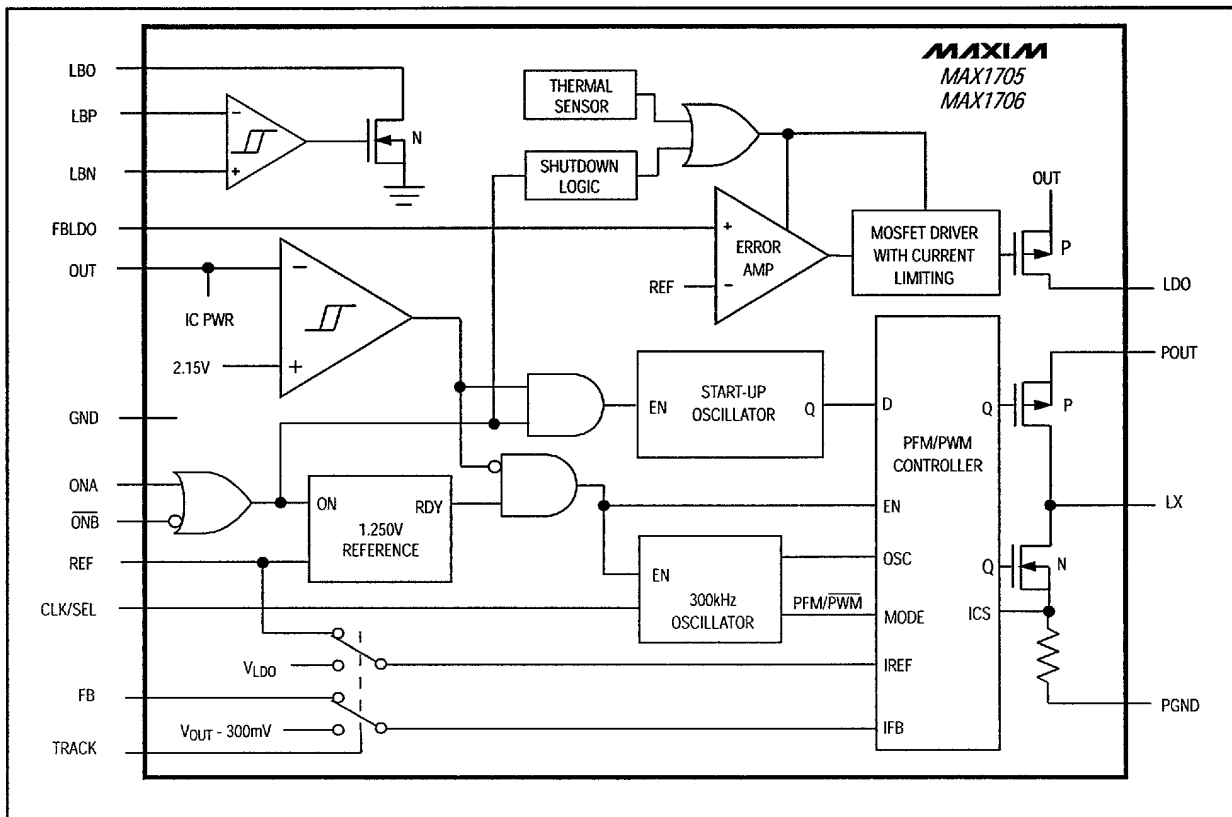

Figure 1. Functional Diagram

1- to 3-Cell, High-Current, Low-Noise, Step-Up DC-DC Converters with Linear Regulator

MAX1705/MAX1706

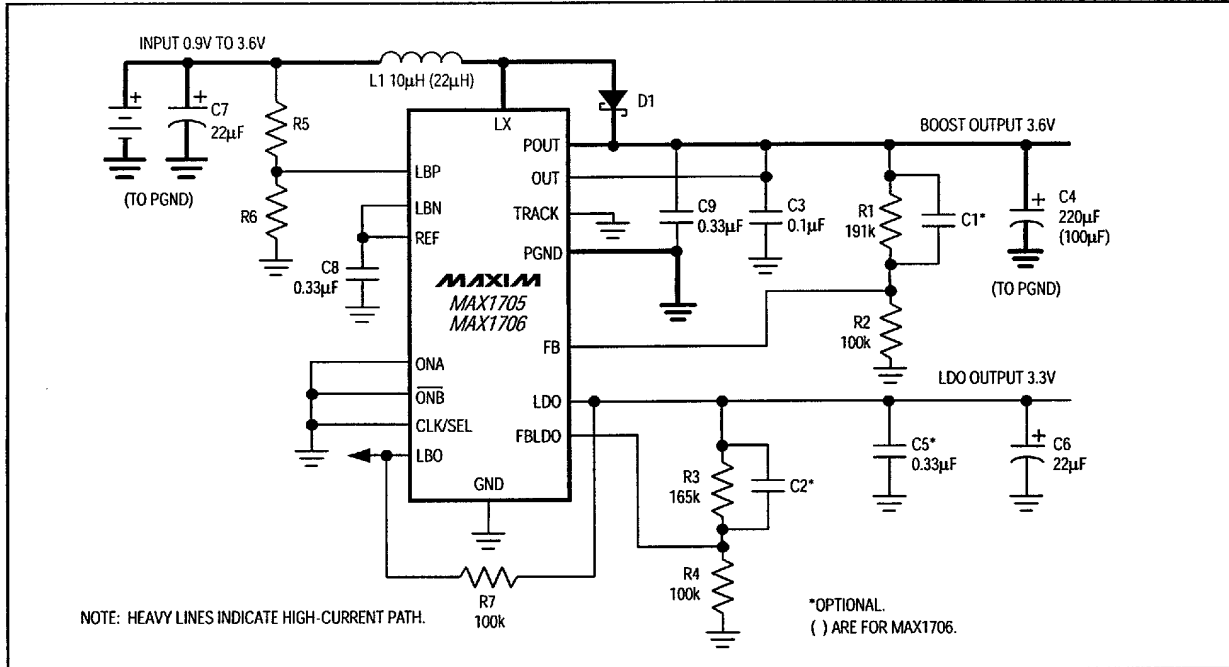

Figure 2. Typical Operating Circuit (PWM Mode)

Step-Up Converter

The step-up switching DC-DC converter generates an adjustable output to supply both power circuitry (such as RF power amplifiers) and the internal low-dropout linear regulator. During the first part of each cycle, the internal N-channel MOSFET switch is turned on. This allows current to ramp up in the inductor and store energy in a magnetic field. During the second part of each cycle, when the MOSFET is turned off, the voltage across the inductor reverses and forces current through the diode and synchronous rectifier to the output filter capacitor and load. As the energy stored in the inductor is depleted, the current ramps down, and the output diode and synchronous rectifier turn off. Voltage across the load is regulated using either PWM or PFM operation, depending on the CLK/SEL pin setting (Table 1).

Low-Noise, High-Power PWM Operation

When CLK/SEL is pulled high, the MAX1705/MAX1706 operate in a high-power, low-noise PWM mode. During PWM operation, they switch at a constant frequency (300kHz), and modulate the MOSFET switch pulse width to control the power transferred per cycle and regulate the voltage across the load. In PWM mode, the

Table 1. Selecting the Operating Mode

CLK/SEL	MODE	FEATURES
0	PFM	Low supply current
1	PWM	Low noise, high output current
External Clock (200kHz to 400kHz)	Synchronized PWM	Low noise, high output current

devices can output up to 850mA. Switching harmonics generated by fixed-frequency operation are consistent and easily filtered.

During PWM operation, each of the internal clock's rising edges sets a flip-flop, which turns on the N-channel MOSFET switch (Figure 3). The switch is turned off when the sum of the voltage-error and current-feed-back signals trips a multi-input comparator and resets the flip-flop; the switch remains off for the rest of the cycle. When a change occurs in the output voltage error signal into the comparator, it shifts the level that the inductor current is allowed to ramp to during each cycle and modulates the MOSFET switch pulse width. A second comparator enforces a 1.55A (max) inductor-

1- to 3-Cell, High-Current, Low-Noise, Step-Up DC-DC Converters with Linear Regulator

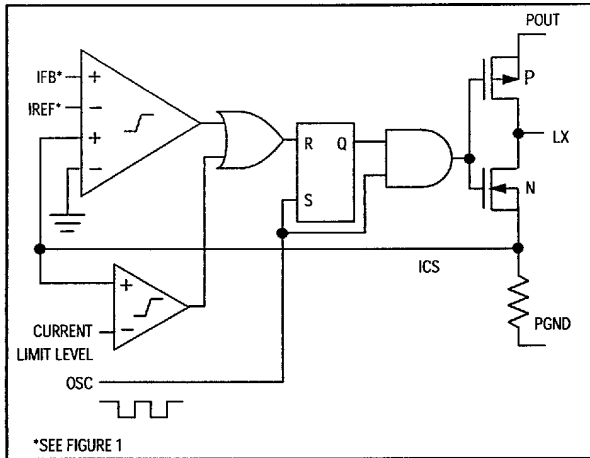

Figure 3. Simplified PWM Controller Block Diagram

current limit for the MAX1705, and 950mA (max) for the MAX1706. During PWM operation, the circuit operates with a continuous inductor current.

Synchronized PWM Operation

The MAX1705/MAX1706 can also be synchronized to a 200kHz to 400kHz frequency by applying an external clock to CLK/SEL. This allows the user to set the harmonics, to avoid IF bands in wireless applications. The synchronous rectifier is also active during synchronized PWM operation.

Low-Power PFM Operation

Pulling CLK/SEL low places the MAX1705/MAX1706 in low-power standby mode. During standby mode, PFM operation regulates the output voltage by transferring a fixed amount of energy during each cycle, and then modulating the switching frequency to control the power delivered to the output. The devices switch only as needed to service the load, resulting in the highest possible efficiency at light loads. Output current capability in PFM mode is 140mA (from 2.4V input to 3.3V output). The output is regulated at 1.3% above the PWM threshold.

During PFM operation, the error comparator detects output voltage falling out of regulation and sets a flip-flop, turning on the N-channel MOSFET switch (Figure 4). When the inductor current ramps to the PFM mode current limit (435mA) and stores a fixed amount of energy, the current-sense comparator resets a flip-flop. The flip-flop turns off the N-channel switch and turns on the P-channel synchronous rectifier. A second flip-flop, previously reset by the switch's "on" signal, inhibits the error comparator from initiating another

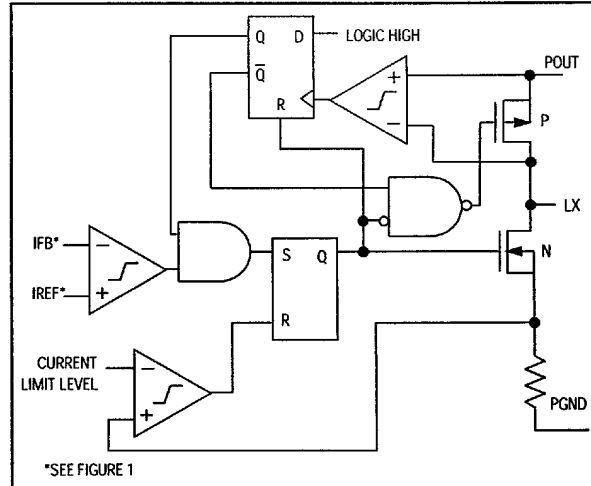

Figure 4. Controller Block Diagram in PFM Mode

cycle until the energy stored in the inductor is dumped into the output filter capacitor and the synchronous rectifier current ramps down to 70mA. This forces operation with a discontinuous inductor current.

Synchronous Rectifier

The MAX1705/MAX1706 feature an internal 270mΩ, P-channel synchronous rectifier to enhance efficiency. Synchronous rectification provides a 5% efficiency improvement over similar nonsynchronous step-up regulators. In PWM mode, the synchronous rectifier is turned on during the second half of each cycle. In PFM mode, an internal comparator turns on the synchronous rectifier when the voltage at LX exceeds the step-up converter output, and then turns it off when the inductor current drops below 70mA.

Linear Regulator

The internal low-dropout linear regulator steps down the output from the step-up converter and reduces switching ripple. It is intended to power noise-sensitive analog circuitry, such as low-noise amplifiers and IF stages in cellular phones and other instruments, and can deliver up to 200mA. However, in practice, the maximum output current is further limited by the current available from the boost converter and by the voltage differential between OUT and LDO. Use a 22μF capacitor with a 1Ω or less equivalent series resistance (ESR) at the output for stability (see the Linear Regulator Region of Stable C6 ESR vs. Load Current graph in the *Typical Operating Characteristics*). During power-up, the linear regulator remains off until the step-up converter goes into regulation for the first time.

1- to 3-Cell, High-Current, Low-Noise, Step-Up DC-DC Converters with Linear Regulator

MAX1705/MAX1706

The linear regulator in the MAX1705/MAX1706 features a 0.5Ω, P-channel MOSFET pass transistor. This provides several advantages, including longer battery life, over similar designs using a PNP pass transistor. The P-channel MOSFET requires no base-drive current, which reduces quiescent current considerably. PNP-based regulators tend to waste base-drive current in dropout when the pass transistor saturates. The MAX1705/MAX1706 eliminate this problem.

The linear-regulator error amplifier compares the output feedback sensed at the FBLDO input against the internal 1.250V reference, and amplifies the difference (Figure 1). The MOSFET driver reads the error signal and applies the appropriate drive to the P-channel pass transistor. If the feedback signal is lower than the reference, the pass-transistor gate is pulled lower, allowing more current to pass to the output, thereby increasing the output voltage. If the feedback voltage is too high, the pass-transistor gate is pulled up, allowing less current to pass to the output. Additional blocks include a current-limiting block and a thermal-overload protection block.

Low-Voltage Start-Up Oscillator

The MAX1705/MAX1706 use a CMOS, low-voltage start-up oscillator for a 1.1V guaranteed minimum start-up input voltage at +25°C. On start-up, the low-voltage oscillator switches the N-channel MOSFET until the output voltage reaches 2.15V. Above this level, the normal step-up converter feedback and control circuitry take over. Once the device is in regulation, it can operate down to a 0.7V input, since internal power for the IC is bootstrapped from the output using the OUT pin.

To reduce current loading during step-up, the linear regulator is kept off until the start-up converter goes into regulation. Minimum start-up voltage is influenced by load and temperature (see the *Typical Operating Characteristics*). To allow proper start-up, do not apply a full load at POUT until after the device has exited start-up mode and entered normal operation.

Shutdown

The MAX1705/MAX1706 feature a shutdown mode that reduces quiescent current to less than 1μA, preserving battery life when the system is not in use. During shutdown, the reference, the low-battery comparator, and all feedback and control circuitry are off. The step-up converter's output drops to one Schottky diode drop below the input, but the linear regulator output is turned off.

Entry into shutdown mode is controlled by logic input pins ONA and ONB (Table 2). Both inputs have trip points near 0.5V_{OUT} with 0.15V_{OUT} hysteresis.

Table 2. On/Off Logic Control

ONA	ONB	MAX1705/MAX1706
0	0	On
0	1	Off
1	0	On
1	1	On

Tracking

Connecting TRACK to the step-up converter output implements a tracking mode that sets the step-up converter output to 300mV above the linear-regulator output, improving efficiency. In track mode, feedback for the step-up converter is derived from the OUT pin. When TRACK is low, the step-up converter and linear regulator are separately controlled by their respective feedback inputs, FB and FBLDO. TRACK is a logic input with a 0.5V_{OUT} threshold, and should be hard-wired or switched with a slew rate exceeding 1V/μs. V_{LDO} must be set above 2.3V for track mode to operate properly.

On power-up with TRACK = OUT, the step-up converter initially uses the FB input to regulate its output. After the step-up converter goes into regulation for the first time, the linear regulator turns on. When the linear regulator reaches 2.3V, track mode is enabled and the step-up converter is regulated to 300mV above the linear-regulator output.

Low-Battery Comparator

The internal low-battery comparator has uncommitted inputs and an open-drain output capable of sinking 1mA. To use it as a low-battery-detection comparator, connect the LBN input to the reference, and connect the LBP input to an external resistor divider between the positive battery terminal and GND (Figure 2). The resistor values are then as follows:

$$R5 = R6 \left(\frac{V_{IN,TH}}{V_{LBN}} - 1 \right)$$

where V_{IN,TH} is the desired input voltage trip point and V_{LBN} = V_{REF} = 1.25V. Since the input bias current into LBP is less than 50nA, R6 can be a large value (such as 270kΩ or less) without sacrificing accuracy. Connect the resistor voltage divider as close to the IC as possible, within 0.2in. (5mm) of the LBP pin. The inputs have a 0.5V to 1.5V common-mode input range, and a 16mV input-referred hysteresis.

1- to 3-Cell, High-Current, Low-Noise, Step-Up DC-DC Converters with Linear Regulator

The low-battery comparator can also be used to monitor the output voltage, as shown in Figure 5.

To set the low-battery threshold to a voltage below the 1.25V reference, insert a resistor divider between REF and LBN, and connect the battery to the LBP input through a 10kΩ current-limiting resistor (Figure 6). The equation for setting the resistors for the low-battery threshold is then as follows:

$$R5 = R6 \left(\frac{V_{REF}}{V_{IN,TH}} - 1 \right)$$

Alternatively, the low-battery comparator can be used to check the output voltage or to control the load directly on POUT during start-up (Figure 7). Use the following equation to set the resistor values:

$$R5 = R6 \left(\frac{V_{OUT,TH}}{V_{LBP}} - 1 \right)$$

where $V_{OUT,TH}$ is the desired output voltage trip point and V_{LBP} is connected to the reference or 1.25V.

Reference

The MAX1705/MAX1706 have an internal 1.250V, 1% bandgap reference. Connect a 0.33μF bypass capacitor to GND within 0.2in. (5mm) of the REF pin. REF can source up to 50μA of external load current.

Design Procedure

Setting the Output Voltages

Set the step-up converter output voltage between 2.5V and 5.5V by connecting a resistor voltage-divider to FB from OUT to GND, as shown in Figure 8. The resistor values are then as follows:

$$R1 = R2 \left(\frac{V_{POUT}}{V_{FB}} - 1 \right)$$

where V_{FB} , the step-up regulator feedback setpoint, is 1.233V. Since the input bias current into FB is less than 50nA, R2 can have a large value (such as 270kΩ or less) without sacrificing accuracy. Connect the resistor voltage-divider as close to the IC as possible, within 0.2in. (5mm) of the FB pin.

Alternatively, set the step-up converter output to track the linear regulator by 300mV. To accomplish this, set TRACK to OUT.

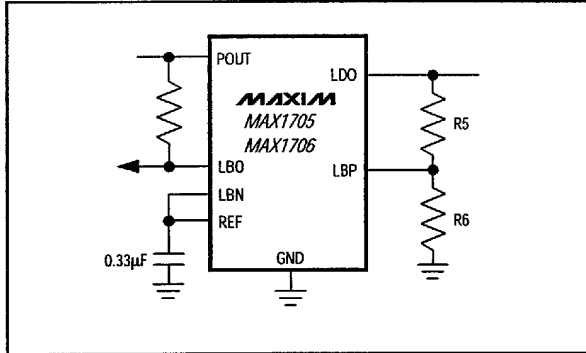

Figure 5. Using the Low-Battery Comparator to Sense the Output Voltage

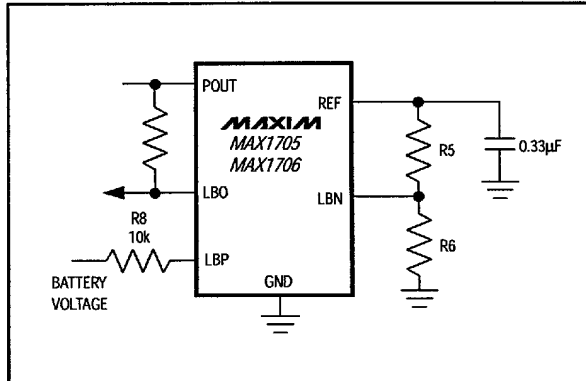

Figure 6. Detecting Battery Voltages Below 1.25V

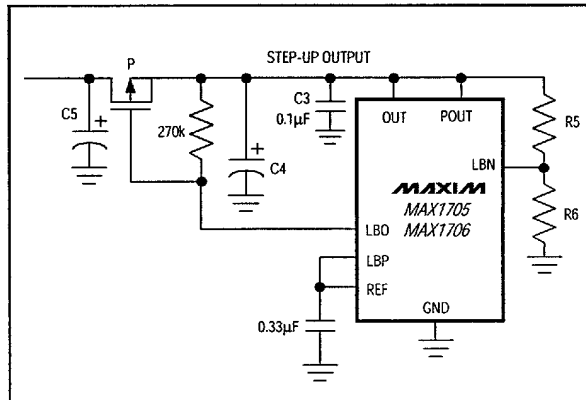

Figure 7. Using the Low-Battery Comparator for Load Control During Start-Up

1- to 3-Cell, High-Current, Low-Noise, Step-Up DC-DC Converters with Linear Regulator

To set the low-dropout linear-regulator output, use a resistor voltage-divider connected to FBLDO from LDO to GND. Set the output to a value at least 300mV less than the step-up converter output using the following formula:

$$R3 = R4 \left(\frac{V_{LDO}}{V_{FBLDO}} - 1 \right)$$

where V_{FBLDO} , the linear-regulator feedback trip point, is 1.250V. Since the input bias current into FBLDO is less than 50nA, R4 can be a large value (such as 270k Ω or less). Connect the resistor voltage-divider as close to the IC as possible, within 0.2in. (5mm) of the FBLDO pin.

Inductor Selection

The MAX1705/MAX1706's high switching frequency allows the use of a small surface-mount inductor. Use a 10 μ H inductor for the MAX1705 and a 22 μ H inductor for the MAX1706. Make sure the saturation-current rating exceeds the N-channel switch current limit of 1.55A for the MAX1705 and 950mA for the MAX1706. For high efficiency, choose an inductor with a high-frequency core material, such as ferrite, to reduce core losses. To minimize radiated noise, use a torroid, pot core, or shielded-bobbin inductor. See Table 3 for suggested parts and Table 4 for a list of inductor suppliers. Connect the inductor from the battery to the LX pin as close to the IC as possible.

Attaching the Output Diode

Use a Schottky diode, such as a 1N5817, MBR0520L, or equivalent. The Schottky diode carries current during start-up, and in PFM mode after the synchronous rectifier turns off. Thus, the current rating only needs to be 500mA. Attach the diode between the LX and POUT pins, as close to the IC as possible.

In high-temperature applications, some Schottky diodes may be unsuitable due to high reverse-leakage currents. Try substituting a Schottky diode with a higher reverse voltage rating, or use an ultra-fast silicon rectifier with reverse recover times less than 60ns (such as a

MUR150 or EC11FS1). Do not use ordinary rectifier diodes, since slow switching speeds and long reverse recovery times compromise efficiency and load regulation.

Choose Input and Output Filter Capacitors

Choose input and output filter capacitors that service the input and output peak currents with acceptable voltage ripple. Choose input capacitors with working voltage ratings over the maximum input voltage, and output capacitors with working voltage ratings higher than the output.

A 100 μ F, 100m Ω , low-ESR tantalum capacitor is recommended at the MAX1706's step-up output. For the MAX1705, use two in parallel or a 220 μ F low-ESR tantalum capacitor. The input filter capacitor (C7) also reduces peak currents drawn from the input source and reduces input switching noise. The input voltage source impedance determines the size required for the input capacitor. When operating directly from one or two NiCd cells placed close to the MAX1705/MAX1706, use a 22 μ F, low-ESR input filter capacitor. When operating from a power source placed farther away, or

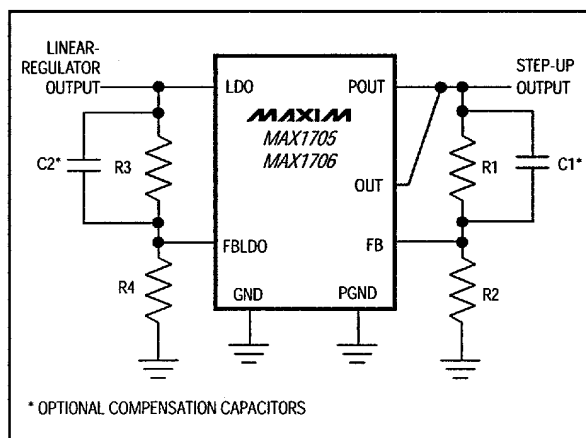

Figure 8. Feedback Connections for the MAX1705/MAX1706

Table 3. Component Selection Guide

PRODUCTION	INDUCTORS	CAPACITORS	DIODES
Surface Mount	Sumida CDR63B, CD73, CDR73B, CD74B series Coilcraft DO1608, DO3308, DT3316 series	Matsuo 267 series Sprague 595D series AVX TPS series	Motorola MBR0520L
Through Hole	Sumida RCH654 series	Sanyo OS-CON series Nichicon PL series	Motorola 1N5817

1- to 3-Cell, High-Current, Low-Noise, Step-Up DC-DC Converters with Linear Regulator

from higher-impedance batteries, consider using one or two 100 μ F, 100m Ω , low-ESR tantalum capacitors.

Low-ESR capacitors are recommended. Capacitor ESR is a major contributor to output ripple—often more than 70%.

Ceramic, Sanyo OS-CON, and Panasonic SP/CB-series capacitors offer the lowest ESR. Low-ESR tantalum capacitors are second best and generally offer a good trade-off between price and performance. Do not exceed the ripple-current ratings of tantalum capacitors. Avoid aluminum-electrolytic capacitors, since their ESR is too high.

Adding Bypass Capacitors

Several ceramic bypass capacitors are required for proper operation of the MAX1705/MAX1706. Bypass REF with a 0.33 μ F capacitor to GND. Connect a 0.1 μ F ceramic capacitor from OUT to GND and a 0.33 μ F ceramic capacitor from POUT to PGND. Place a 22 μ F, low-ESR capacitor and an optional 0.33 μ F ceramic capacitor from the linear-regulator output LDO to GND. An optional 22pF ceramic capacitor can be added to the linear-regulator feedback network to reduce noise (C2, Figure 2). Place each of these as close to their respective pins as possible, within 0.2in. (5mm) of the DC-DC converter IC. High-value, low-voltage, surface-mount ceramic capacitors are now readily available in small packages; see Table 4 for suggested suppliers.

Designing a PC Board

High switching frequencies and large peak currents make PC board layout an important part of design. Poor design can cause excessive EMI and ground-bounce, both of which can cause instability or regulation errors by corrupting voltage- and current-feedback signals. It is highly recommended that the PC board example of the MAX1705 evaluation kit (EV kit) be followed.

Power components—such as the inductor, converter IC, filter capacitors, and output diode—should be placed as close together as possible, and their traces should be kept short, direct, and wide. Place the LDO output capacitor as close to the LDO pin as possible. Make the connection between POUT and OUT very short. Keep the extra copper on the board, and integrate it into ground as a pseudo-ground plane.

On multilayer boards, do not connect the ground pins of the power components using vias through an internal

Table 4. Component Suppliers

SUPPLIER	PHONE	FAX
AVX	USA: (803) 946-0690 (800) 282-4975	(803) 626-3123
Coilcraft	USA: (847) 639-6400	(847) 639-1469
Matsuo	USA: (714) 969-2491	(714) 960-6492
Motorola	USA: (602) 303-5454	(602) 994-6430
Sanyo	USA: (619) 661-6835 Japan: 81-7-2070-6306	(619) 661-1055 81-7-2070-1174
Sumida	USA: (847) 956-0666 Japan: 81-3-3607-5111	(847) 956-0702 81-3-3607-5144

ground plane. Instead, place them close together and route them in a star-ground configuration using component-side copper. Then connect the star ground to the internal ground plane using vias.

Keep the voltage-feedback networks very close to the MAX1705/MAX1706—within 0.2in. (5mm) of the FB and FBLDO pins. Keep noisy traces, such as from the LX pin, away from the reference and voltage-feedback networks, especially the LDO feedback, and separated from them using grounded copper. Consult the MAX1705/MAX1706 EV kit for a full PC board example.

Applications Information

Use in a Typical Wireless Phone Application

The MAX1705/MAX1706 are ideal for use in digital cordless and PCS phones. The power amplifier (PA) is connected directly to the step-up converter output for maximum voltage swing (Figure 9). The internal linear regulator is used for post-regulation to generate low-noise power for DSP, control, and RF circuitry. Typically, RF phones spend most of their life in standby mode and short periods in transmit/receive mode. During standby, maximize battery life by setting CLK/SEL = GND and TRACK = OUT; this places the IC in PFM and track modes (for lowest quiescent power consumption). In transmit/receive mode, set TRACK = GND and CLK/SEL = OUT to increase the PA supply voltage and initiate high-power, low-noise PWM operation. Table 5 lists the typical available output current when operating with one or more NiCd/NiMH cells or one Li-Ion cell.

1- to 3-Cell, High-Current, Low-Noise, Step-Up DC-DC Converters with Linear Regulator

MAX1705/MAX1706

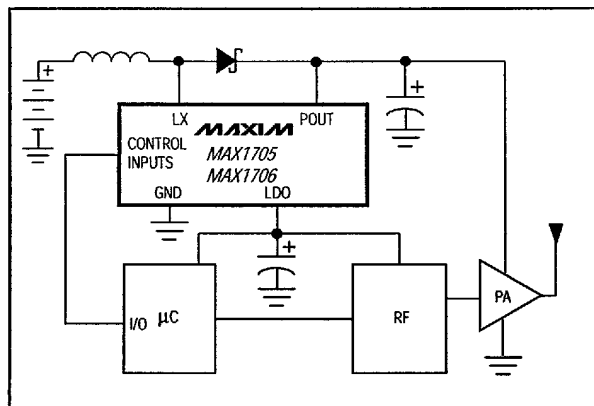

Figure 9. Typical Phone Application

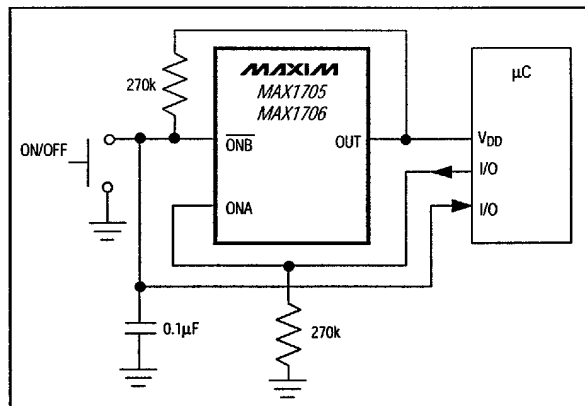

Figure 10. Momentary Pushbutton On/Off Switch

Table 5. Typical Available Output Current

NUMBER OF CELLS	INPUT VOLTAGE (V)	STEP-UP OUTPUT VOLTAGE: (PA POWER SUPPLY) (V)	TOTAL OUTPUT CURRENT (mA)	
			MAX1705	MAX1706
1 NiCd/NiMH	1.2	3.3	300	200
2 NiCd/NiMH	2.4	3.3	730	450
2 NiCd/NiMH	2.4	5.0	500	350
3 NiCd/NiMH or 1 Li-Ion	3.6	5.0	850	550

Implementing Soft-Start

To implement soft-start, set CLK/SEL low on power-up; this forces PFM operation and reduces the peak switching current to 435mA. Once the circuit is in regulation, CLK/SEL can be set high for full-power operation.

Adding a Manual Power Reset

A momentary pushbutton switch can be used to turn the MAX1705/MAX1706 on and off (Figure 10). ONA is pulled low and $\overline{\text{ONB}}$ is pulled high to turn the part off. When the momentary switch is pressed, $\overline{\text{ONB}}$ is pulled low and the regulator turns on. The switch must be pressed long enough for the microcontroller (μC) to exit reset (200ms) and drive ONA high. A small capacitor is added to help debounce the switch. The μC issues a logic high to ONA, which holds the part on regardless of the switch state. To turn the regulator off, press the switch again, allowing the μC to read the switch status and pull ONA low. When the switch is released, $\overline{\text{ONB}}$ is pulled high.

Chip Information

TRANSISTOR COUNT: 1649
SUBSTRATE CONNECTED TO GND

1- to 3-Cell, High-Current, Low-Noise, Step-Up DC-DC Converters with Linear Regulator

Tape-and-Reel Information

MAX1705/MAX1706

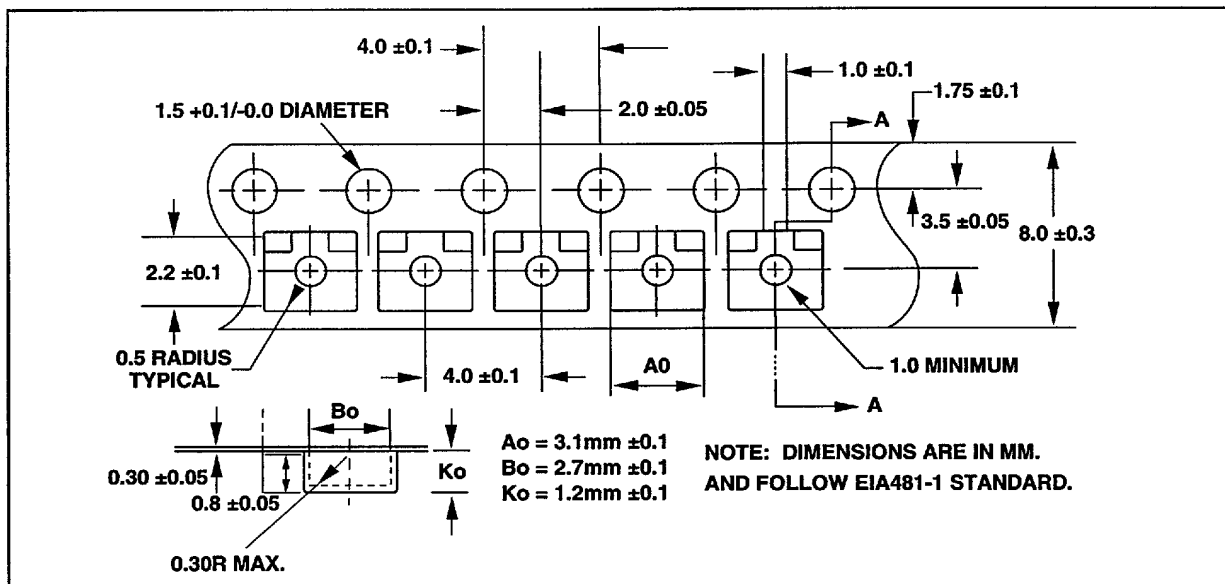

1- to 3-Cell, High-Current, Low-Noise, Step-Up DC-DC Converters with Linear Regulator

Package Information

MAX1705/MAX1706

