

Spec No.	SS-024
Data	Oct 30, 2003
Version	First

SPECIFICATION

Product name Rodan Spark Gap
Type RSG-802-BQL

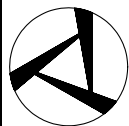

Spec No.	SS-024
Data	Oct 30, 2003
Version	First

1. Scope This specification covers Rodan Spark Gap RSG-802-BQL.

2. Type designation

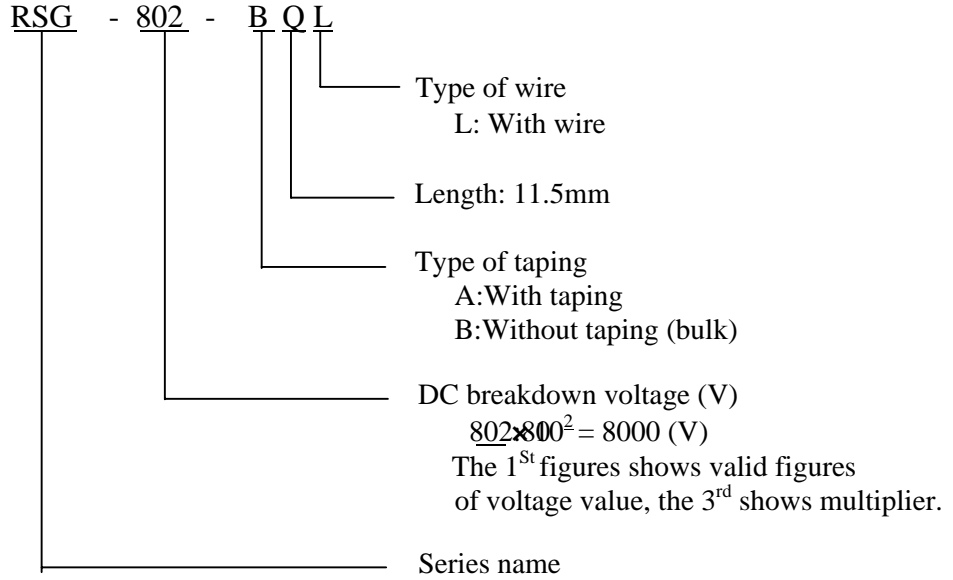

3. Appearance Structure

3-1 Dimension Refer to drawing 4R-4198-Y89

3-2 Display and contents Marking must not be disappeared easily, and it has to be identified.

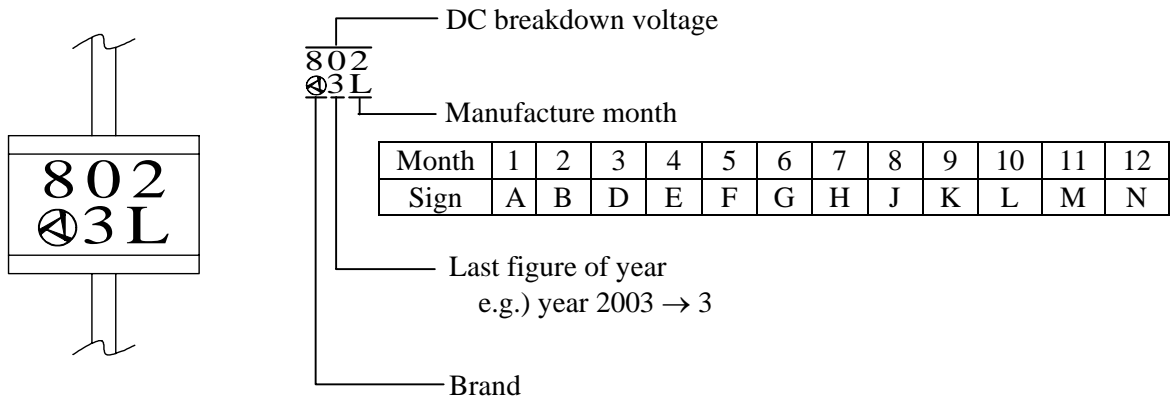
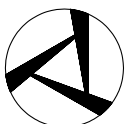

Fig.1 Example of marking

3-3 Materials Ceramic, Electrode, Lead wire etc

3-4 Plating treatment Tinning

3-5 Filler gas Ar, mixed gas This product doesn't use radioisotope.



Spec No.	SS-024	P:3/5
Data	Oct 30, 2003	
Version	First	

4. Electrical characteristics

No.	Item	Mark	Test condition		Standard values
1	DC breakdown voltage	Ez	1 MΩ , 500 V/s		8000 V ±20 %
2	Insulation resistance	IR	DC100 V		1000 MΩ Min
3	Electrostatic capacitance	C	1.0 kHz		2.0 pF Max
4	Life test	-	Switching frequency	100 Hz	DC breakdown Voltage 8000 V ⁺²⁰ ₋₂₅ %
			Switching times	5 s ON / 55 s OFF	
			Ambient temperature	Room temperature	
			Test circuit		<p style="text-align: center;">* R is adjusted</p>
Minimum number of switching is 10 ⁵ times, according to the above condition.					



Spec No.	SS-024
Data	Oct 30, 2003
Version	First

5. Switching frequency

Maximum switching frequency : 200 Hz

6. Operating condition

Operating temperature : -40 to +100

7. Storage condition

Storage temperature : -40 to +100

8. About forming

As regards forming of spark gap, please take distance more than 2mm from main body when you bend lead wire.
When performing a forming, please hold only lead wire and be careful not to give a stress on main body.

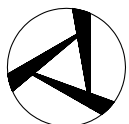
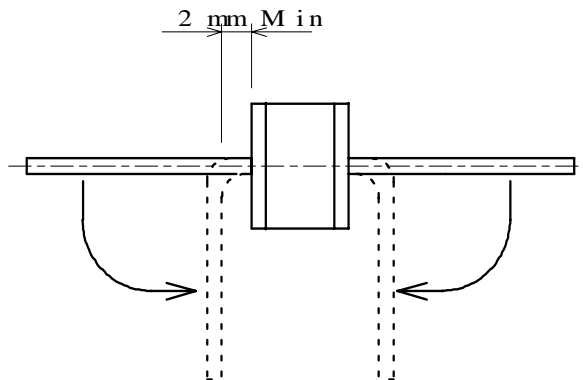

Spec No.	SS-024
Data	Oct 30, 2003
Version	First

9. Packing

Put 50 pcs. of RSG series and 1pc. of product label in a vinyl bag of specified size, seal the bag with a heatseal, put bags of quantity required a box, pack and stick product label on the box.

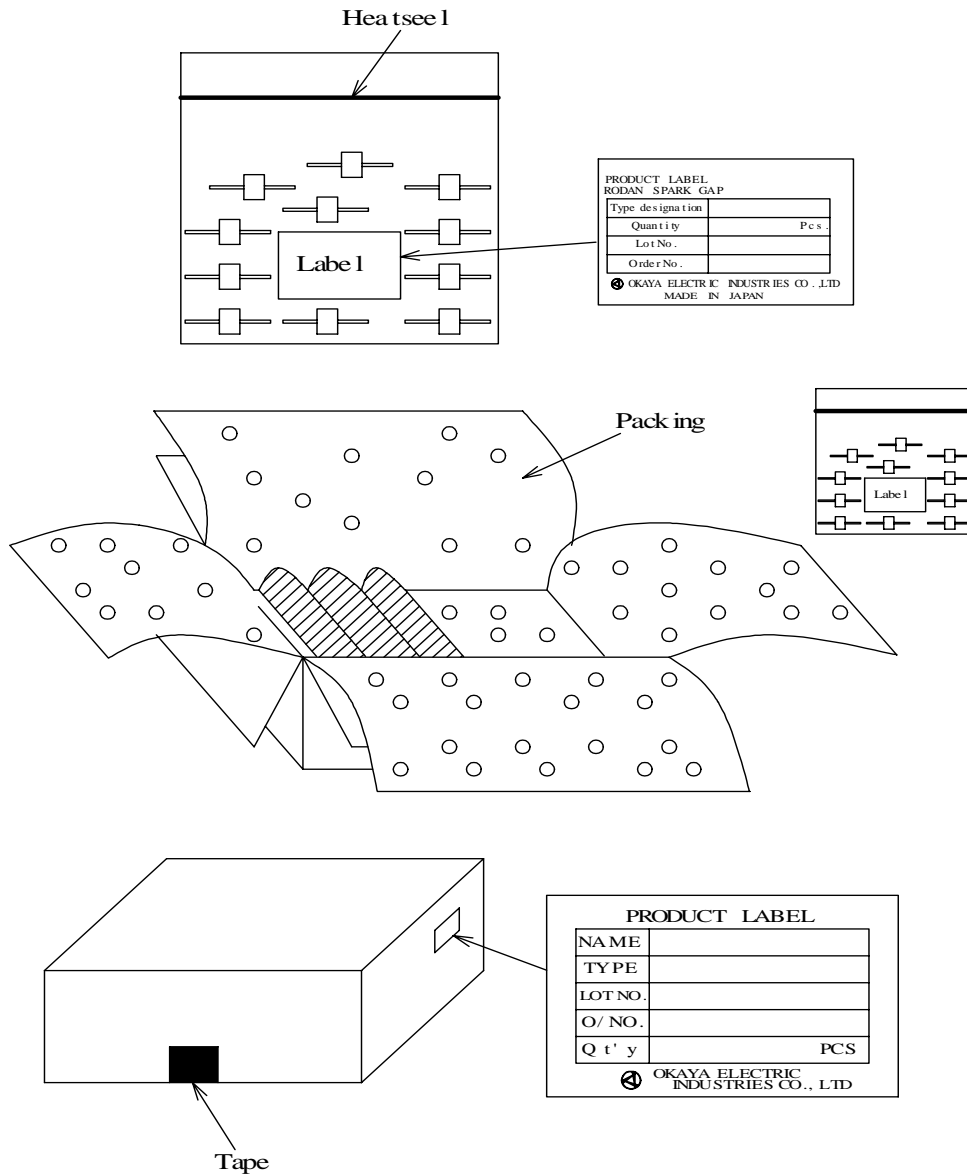

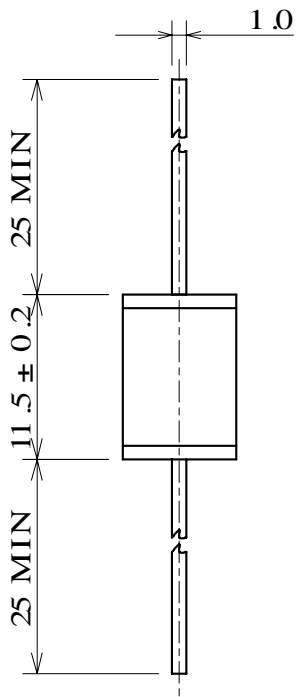
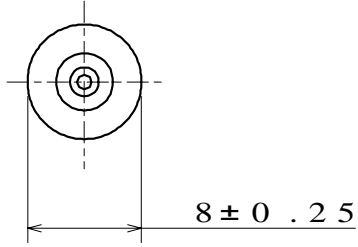

Weight: approx. 2.5 g

Ver.	Rev. data	History of rev.	Date	Scale	Product name	
			2003.10.30	2:1	Rodan spark gap	
					Type name	
					Outline dimension (8.0X 11.5 L)	
					Drawing No.	
OKAYA ELECTRIC AMERICA, INC.					4 R- 4198- Y89	4