

RD74VT1G08

2-input AND Gate / Dual Supply Voltage Translator

REJ03D0495-0100

Rev.1.00

Feb. 01, 2005

Description

The RD74VT1G08 has two-input AND gate in a 6 pin package. The input is designed to track V_{CCIN} , which accepts voltages from 1.2 V to 3.6 V, and the output is designed to track V_{CCOUT} , which operates at 1.2 V to 3.6 V. Low voltage and high-speed operation is suitable for the battery powered products (e.g., notebook computers), and the low power consumption extends the battery life.

Features

- This product function as level shift that change V_{CCIN} input level to V_{CCOUT} output level by providing different supply voltage to V_{CCIN} and V_{CCOUT} .
- Supplied on emboss taping for high-speed automatic mounting.
- Supply voltage range:
 - $V_{CCIN} = 1.2 \text{ V to } 3.6 \text{ V}$
 - $V_{CCOUT} = 1.2 \text{ V to } 3.6 \text{ V}$
- Operating temperature range: $-40 \text{ to } +85^{\circ}\text{C}$
- All inputs $V_{IH}(\text{Max.}) = 3.6 \text{ V} (@V_{CCIN} = 0 \text{ V to } 3.6 \text{ V})$
All outputs $V_O(\text{Max.}) = 3.6 \text{ V} (@V_{CCOUT} = 0 \text{ V})$
- Output current
 - $\pm 2 \text{ mA} (@V_{CCOUT} = 1.2 \text{ V})$
 - $\pm 4 \text{ mA} (@V_{CCOUT} = 1.4 \text{ V to } 1.6 \text{ V})$
 - $\pm 6 \text{ mA} (@V_{CCOUT} = 1.65 \text{ V to } 1.95 \text{ V})$
 - $\pm 18 \text{ mA} (@V_{CCOUT} = 2.3 \text{ V to } 2.7 \text{ V})$
 - $\pm 24 \text{ mA} (@V_{CCOUT} = 3.0 \text{ V to } 3.6 \text{ V})$

- Ordering Information

Part Name	Package Type	Package Code (Previous Code)	Package Abbreviation	Taping Abbreviation (Quantity)
RD74VT1G08CLE	WCSP-6 pin	SXBG0006KB-A (TBS-6AV)	CL	E (3,000 pcs / reel)

Article Indication

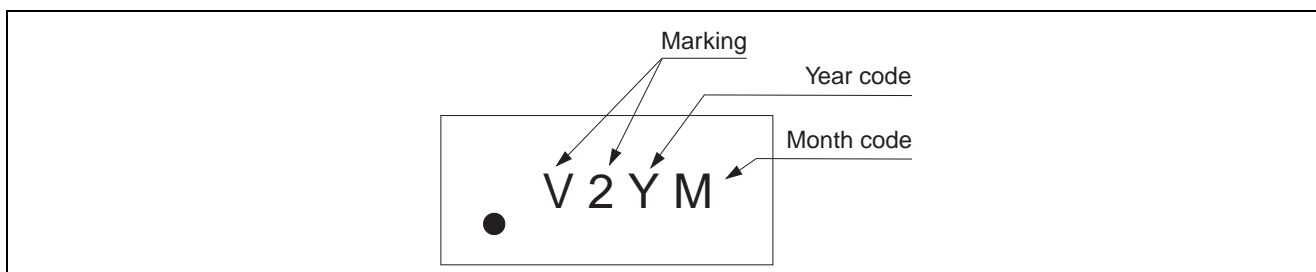

Function Table

Inputs		OUTPUT Y
A	B	
L	L	L
H	L	L
L	H	L
H	H	H

H: High level
L: Low level

Pin Arrangement

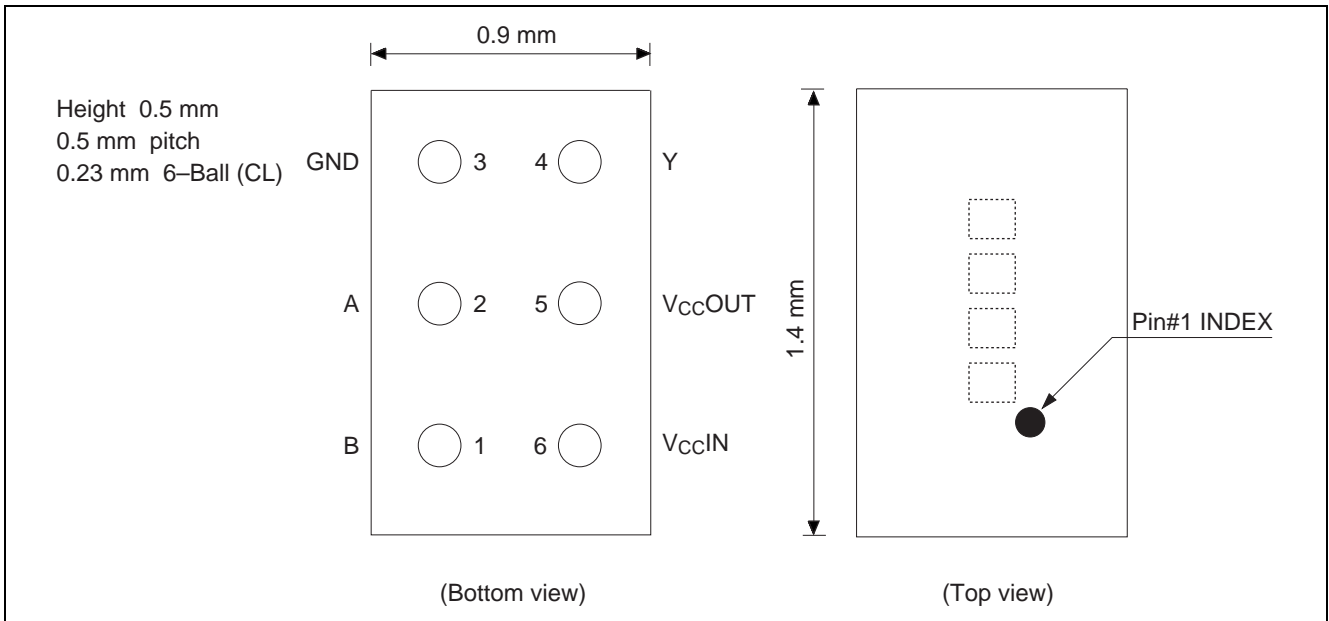

Logic Diagram

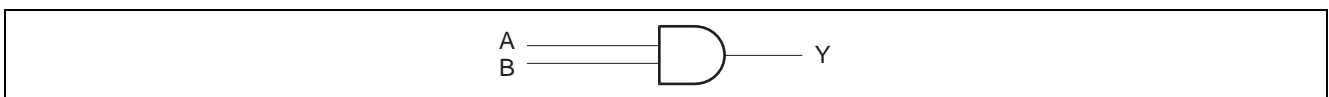

Absolute Maximum Ratings

Item	Symbol	Ratings	Unit	Conditions
Supply voltage range	V_{CCIN}, V_{CCOUT}	-0.5 to 4.6	V	
Input voltage range ^{*1}	V_I	-0.5 to 4.6	V	
Output voltage range ^{*1, 2}	V_O	-0.5 to $V_{CCOUT}+0.5$	V	Output: "H" or "L"
		-0.5 to 4.6		V_{CCOUT} : OFF
Input clamp current	I_{IK}	-50	mA	$V_I < 0$
Output clamp current	I_{OK}	-50	mA	$V_O < 0$
		50		$V_O > V_{CC}+0.5$
Continuous output current	I_O	± 50	mA	
Continuous output current V_{CC} or GND	$I_{CCIN}, I_{CCOUT}, I_{GND}$	± 100	mA	
Package Thermal impedance	θ_{ja}	123	$^{\circ}C/W$	
Storage temperature	T_{stg}	-65 to 150	$^{\circ}C$	

Notes: The absolute maximum ratings are values, which must not individually be exceeded, and furthermore, no two of which may be realized at the same time.

- The input and output voltage ratings may be exceeded if the input and output clamp-current ratings are observed.
- This value is limited to 4.6 V maximum.

Recommended Operating Conditions

Item	Symbol	Ratings	Unit	Conditions
Supply voltage range	V_{CCIN}	1.2 to 3.6	V	
	V_{CCOUT}	1.2 to 3.6		
Input/Output voltage	V_I	0 to 3.6	V	
	V_O	0 to 3.6	V	Output: "H" or "L"
0 to V_{CCOUT}		V_{CCOUT} : OFF		
Output current	I_{OH}	-2	mA	$V_{CCOUT} = 1.2$ V
		-4		$V_{CCOUT} = 1.5 \pm 0.1$ V
		-6		$V_{CCOUT} = 1.8 \pm 0.15$ V
		-18		$V_{CCOUT} = 2.5 \pm 0.2$ V
		-24		$V_{CCOUT} = 3.3 \pm 0.3$ V
	I_{OL}	2	mA	$V_{CCOUT} = 1.2$ V
		4		$V_{CCOUT} = 1.5 \pm 0.1$ V
		6		$V_{CCOUT} = 1.8 \pm 0.15$ V
		18		$V_{CCOUT} = 2.5 \pm 0.2$ V
		24		$V_{CCOUT} = 3.3 \pm 0.3$ V
Input transition rise or fall time	$\Delta t / \Delta v$	10	ns / V	
Operation free-air temperature	T_a	-40 to 85	$^{\circ}C$	

Electrical Characteristics

(Ta = -40 to 85°C)

Item	Symbol	V _{CCIN} (V) *	V _{CCOUT} (V) *	Min	Typ	Max	Unit	Test conditions
Input voltage	V _{IH}	1.2	1.2 to 3.6	V _{CCIN} ×0.75	—	—	V	
		1.5±0.1		V _{CCIN} ×0.70	—	—		
		1.8±0.15		V _{CCIN} ×0.65	—	—		
		2.5±0.2		1.6	—	—		
		3.3±0.3		2.0	—	—		
	V _{IL}	1.2	1.2 to 3.6	—	—	V _{CCIN} ×0.25	V	
		1.5±0.1		—	—	V _{CCIN} ×0.30		
		1.8±0.15		—	—	V _{CCIN} ×0.35		
		2.5±0.2		—	—	0.7		
		3.3±0.3		—	—	0.8		
Output voltage	V _{OH}	1.2 to 3.6	1.2 to 3.6	V _{CCOUT} -0.2	—	—	V	I _{OH} = -100 μA
			1.2	0.9	—	—		I _{OH} = -2 mA
			1.5±0.1	1.1	—	—		I _{OH} = -4 mA
			1.8±0.15	1.25	—	—		I _{OH} = -6 mA
			2.5±0.2	1.7	—	—		I _{OH} = -18 mA
			3.3±0.3	2.2	—	—		I _{OH} = -24 mA
	V _{OL}	1.2 to 3.6	1.2 to 3.6	—	—	0.2	V	I _{OL} = 100 μA
			1.2	—	—	0.3		I _{OL} = 2 mA
			1.5±0.1	—	—	0.3		I _{OL} = 4 mA
			1.8±0.15	—	—	0.3		I _{OL} = 6 mA
			2.5±0.2	—	—	0.6		I _{OL} = 18 mA
			3.3±0.3	—	—	0.55		I _{OL} = 24 mA
Input current	I _{IN}	3.6	3.6	-1.0	—	1.0	μA	V _{IN} = GND or V _{CCIN}
Output leakage current	I _{OFF}	0	0	—	—	1.5	μA	V _{IN} , V _{OUT} = 0 to 3.6 V
Quiescent supply current	I _{CCIN}	1.2 to 3.6	1.2 to 3.6	-3.0	—	3.0	μA	I _{O(Y port)} = 0 V _{IN} = V _{CCIN} or GND
	I _{CCOUT}	1.2 to 3.6	1.2 to 3.6	-3.0	—	3.0		I _{O(Y port)} = 0 V _{IN} = V _{CCIN} or GND
Increase in I _{CC} per input	ΔI _{CC}	3.6	3.6	—	—	250	μA	A or B port V _{CCIN} -0.6 (1 input)
Input capacitance	C _{IN}	3.3	3.3	—	3.5	—	pF	V _{IN} = V _{CC} or GND

Note: For conditions shown as Min or Max, use the appropriate values under recommended operating conditions.

Switching Characteristics

V_{CCIN} = 3.3±0.3 V

Item	Symbol	From (input)	To (output)	Ta = -40 to 85°C										Unit	Test conditions
				V _{CCOUT} = 1.2 V		V _{CCOUT} = 1.5±0.1 V		V _{CCOUT} = 1.8±0.15 V		V _{CCOUT} = 2.5±0.2 V		V _{CCOUT} = 3.3±0.3 V			
				Typ	Min	Max	Min	Max	Min	Max	Min	Max	Min		
Propagation delay time	t _{PLH}	A or B	Y	8.4	2.0	7.8	1.5	5.2	1.0	4.1	1.0	3.5	ns	C _L = 15pF R _L = 2.0kΩ	
	t _{PHL}			8.4	2.0	7.8	1.5	5.2	1.0	4.1	1.0	3.5			

Switching Characteristics (Cont.)

$V_{CCIN} = 2.5 \pm 0.2 \text{ V}$

Item	Symbol	From (input)	To (output)	Ta = -40 to 85°C										Unit	Test conditions
				V _{CC} OUT= 1.2 V		V _{CC} OUT= 1.5±0.1 V		V _{CC} OUT= 1.8±0.15 V		V _{CC} OUT= 2.5±0.2 V		V _{CC} OUT= 3.3±0.3 V			
				Typ	Min	Max	Min	Max	Min	Max	Min	Max	Min		
Propagation delay time	t _{PLH}	A or B	Y	8.5	2.0	8.2	1.5	5.5	1.0	4.3	1.0	3.9	ns	C _L = 15pF R _L = 2.0kΩ	
	t _{PHL}			8.5	2.0	8.2	1.5	5.5	1.0	4.3	1.0	3.9			

$V_{CCIN} = 1.8 \pm 0.15 \text{ V}$

Item	Symbol	From (input)	To (output)	Ta = -40 to 85°C										Unit	Test conditions
				V _{CC} OUT= 1.2 V		V _{CC} OUT= 1.5±0.1 V		V _{CC} OUT= 1.8±0.15 V		V _{CC} OUT= 2.5±0.2 V		V _{CC} OUT= 3.3±0.3 V			
				Typ	Min	Max	Min	Max	Min	Max	Min	Max	Min		
Propagation delay time	t _{PLH}	A or B	Y	8.7	2.0	8.6	1.5	6.6	1.0	5.9	1.0	5.5	ns	C _L = 15pF R _L = 2.0kΩ	
	t _{PHL}			8.7	2.0	8.6	1.5	6.6	1.0	5.9	1.0	5.5			

$V_{CCIN} = 1.5 \pm 0.1 \text{ V}$

Item	Symbol	From (input)	To (output)	Ta = -40 to 85°C										Unit	Test conditions
				V _{CC} OUT= 1.2 V		V _{CC} OUT= 1.5±0.1 V		V _{CC} OUT= 1.8±0.15 V		V _{CC} OUT= 2.5±0.2 V		V _{CC} OUT= 3.3±0.3 V			
				Typ	Min	Max	Min	Max	Min	Max	Min	Max	Min		
Propagation delay time	t _{PLH}	A or B	Y	8.9	2.0	10.0	1.5	8.4	1.0	7.4	1.0	7.2	ns	C _L = 15pF R _L = 2.0kΩ	
	t _{PHL}			8.9	2.0	10.0	1.5	8.4	1.0	7.4	1.0	7.2			

$V_{CCIN} = 1.2 \text{ V}$

Item	Symbol	From (input)	To (output)	Ta = -40 to 85°C										Unit	Test conditions
				V _{CC} OUT= 1.2 V		V _{CC} OUT= 1.5±0.1 V		V _{CC} OUT= 1.8±0.15 V		V _{CC} OUT= 2.5±0.2 V		V _{CC} OUT= 3.3±0.3 V			
				Typ	Typ	Typ	Typ	Typ	Typ	Typ	Typ	Typ	Typ		
Propagation delay time	t _{PLH}	A or B	Y	10.5	9.0	8.2	7.6	7.5	ns	C _L = 15pF R _L = 2.0kΩ					
	t _{PHL}			10.5	9.0	8.2	7.6	7.5							

Operating Characteristics

$T_a = 25^\circ\text{C}$

Item	Symbol	V _{CC} IN (V)	V _{CC} OUT (V)	Min	Typ	Max	Unit	Test conditions
Power dissipation capacitance	C _{PD}	3.3	3.3	—	12	—	pF	f = 10 MHz C _L = 0

Power-up Considerations

Level-translation devices offer an opportunity for successful mixed-voltage signal design.

A proper power-up sequence always should be followed to avoid excessive supply current, bus contention, oscillations, or other anomalies caused by improperly biased device pins.

Take these precautions to guard against such power-up problems.

1. Connect ground before any supply voltage is applied.
2. Next, power up the input side of the device.
(Power up of V_{CC}IN is first. Next power up is V_{CC}OUT)

Test Circuit

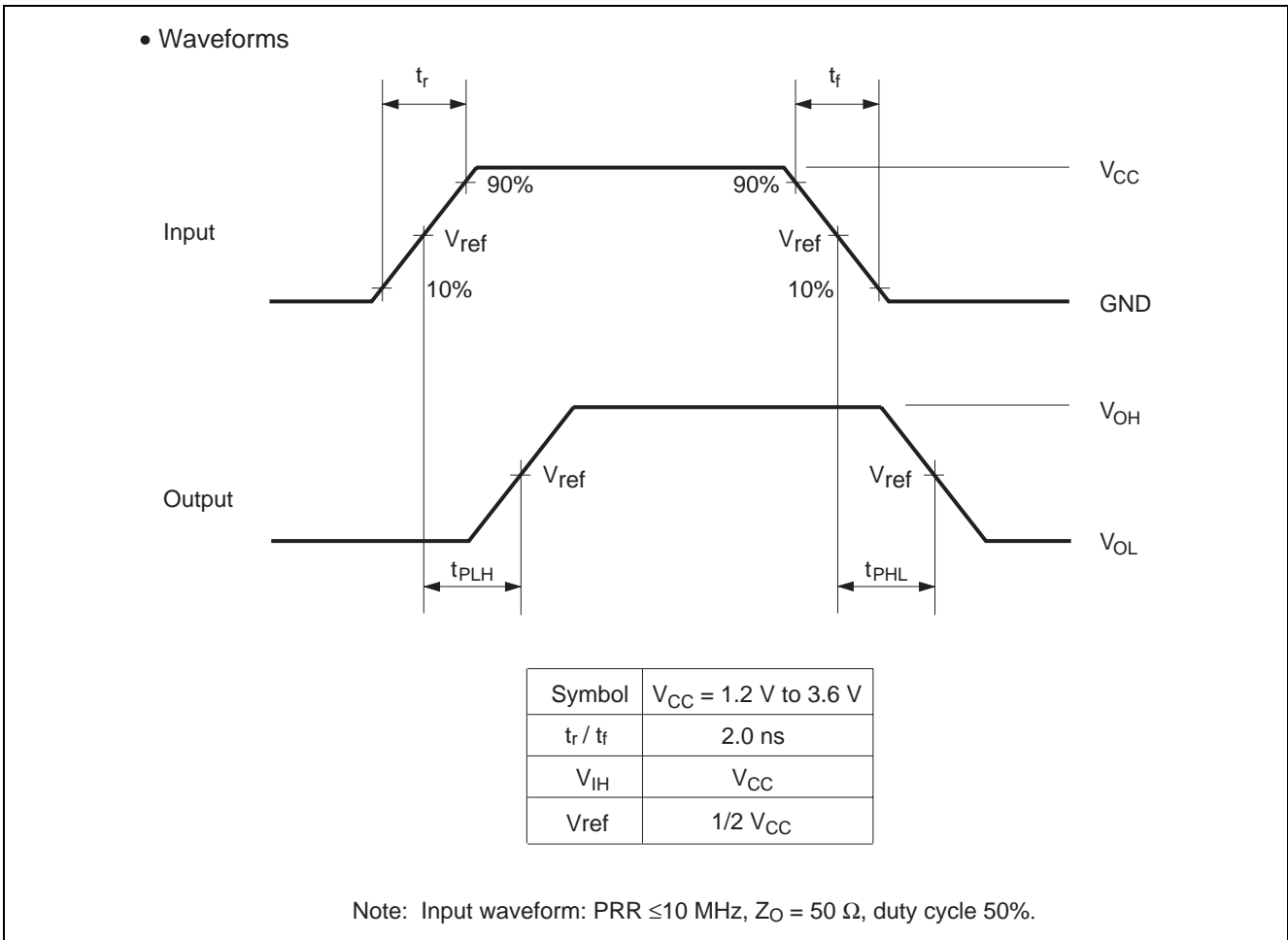
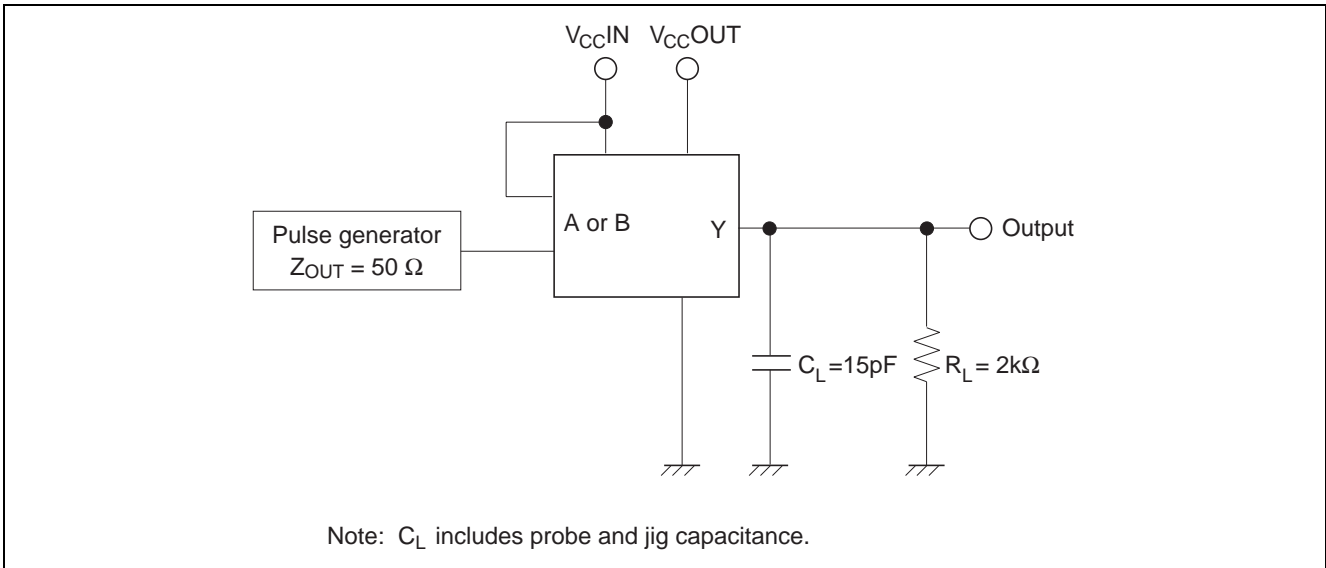

Package Dimensions

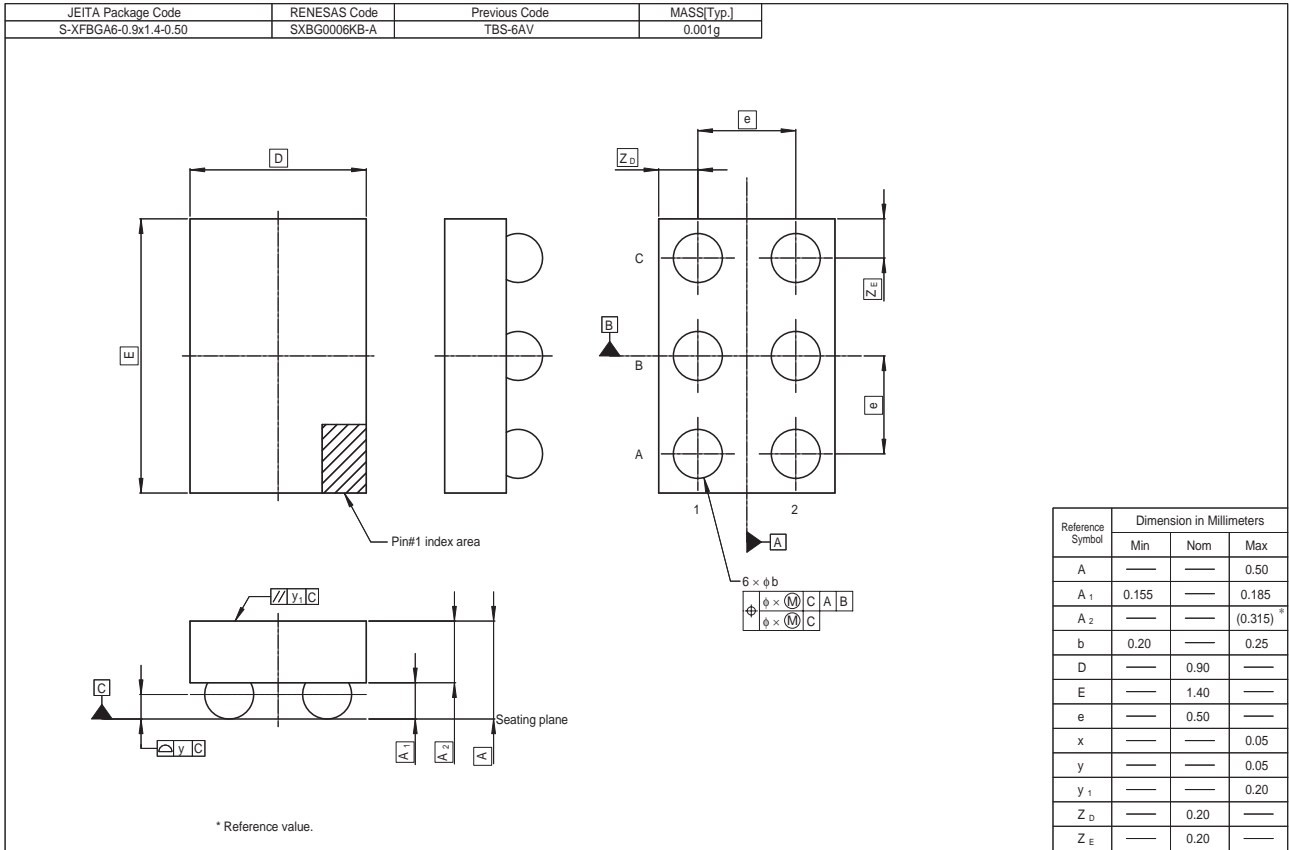

Renesas Technology Corp. Sales Strategic Planning Div. Nippon Bldg., 2-6-2, Ohte-machi, Chiyoda-ku, Tokyo 100-0004, Japan

Keep safety first in your circuit designs!

1. Renesas Technology Corp. puts the maximum effort into making semiconductor products better and more reliable, but there is always the possibility that trouble may occur with them. Trouble with semiconductors may lead to personal injury, fire or property damage.
Remember to give due consideration to safety when making your circuit designs, with appropriate measures such as (i) placement of substitutive, auxiliary circuits, (ii) use of nonflammable material or (iii) prevention against any malfunction or mishap.

Notes regarding these materials

1. These materials are intended as a reference to assist our customers in the selection of the Renesas Technology Corp. product best suited to the customer's application; they do not convey any license under any intellectual property rights, or any other rights, belonging to Renesas Technology Corp. or a third party.
2. Renesas Technology Corp. assumes no responsibility for any damage, or infringement of any third-party's rights, originating in the use of any product data, diagrams, charts, programs, algorithms, or circuit application examples contained in these materials.
3. All information contained in these materials, including product data, diagrams, charts, programs and algorithms represents information on products at the time of publication of these materials, and are subject to change by Renesas Technology Corp. without notice due to product improvements or other reasons. It is therefore recommended that customers contact Renesas Technology Corp. or an authorized Renesas Technology Corp. product distributor for the latest product information before purchasing a product listed herein.
The information described here may contain technical inaccuracies or typographical errors.
Renesas Technology Corp. assumes no responsibility for any damage, liability, or other loss rising from these inaccuracies or errors.
Please also pay attention to information published by Renesas Technology Corp. by various means, including the Renesas Technology Corp. Semiconductor home page (<http://www.renesas.com>).
4. When using any or all of the information contained in these materials, including product data, diagrams, charts, programs, and algorithms, please be sure to evaluate all information as a total system before making a final decision on the applicability of the information and products. Renesas Technology Corp. assumes no responsibility for any damage, liability or other loss resulting from the information contained herein.
5. Renesas Technology Corp. semiconductors are not designed or manufactured for use in a device or system that is used under circumstances in which human life is potentially at stake. Please contact Renesas Technology Corp. or an authorized Renesas Technology Corp. product distributor when considering the use of a product contained herein for any specific purposes, such as apparatus or systems for transportation, vehicular, medical, aerospace, nuclear, or undersea repeater use.
6. The prior written approval of Renesas Technology Corp. is necessary to reprint or reproduce in whole or in part these materials.
7. If these products or technologies are subject to the Japanese export control restrictions, they must be exported under a license from the Japanese government and cannot be imported into a country other than the approved destination.
Any diversion or reexport contrary to the export control laws and regulations of Japan and/or the country of destination is prohibited.
8. Please contact Renesas Technology Corp. for further details on these materials or the products contained therein.



RENESAS SALES OFFICES

<http://www.renesas.com>

Refer to "<http://www.renesas.com/en/network>" for the latest and detailed information.

Renesas Technology America, Inc.
450 Holger Way, San Jose, CA 95134-1368, U.S.A
Tel: <1> (408) 382-7500, Fax: <1> (408) 382-7501

Renesas Technology Europe Limited
Dukes Meadow, Millboard Road, Bourne End, Buckinghamshire, SL8 5FH, U.K.
Tel: <44> (1628) 585-100, Fax: <44> (1628) 585-900

Renesas Technology Hong Kong Ltd.
7th Floor, North Tower, World Finance Centre, Harbour City, 1 Canton Road, Tsimshatsui, Kowloon, Hong Kong
Tel: <852> 2265-6688, Fax: <852> 2730-6071

Renesas Technology Taiwan Co., Ltd.
10th Floor, No.99, Fushing North Road, Taipei, Taiwan
Tel: <886> (2) 2715-2888, Fax: <886> (2) 2713-2999

Renesas Technology (Shanghai) Co., Ltd.
Unit2607 Ruijing Building, No.205 Maoming Road (S), Shanghai 200020, China
Tel: <86> (21) 6472-1001, Fax: <86> (21) 6415-2952

Renesas Technology Singapore Pte. Ltd.
1 Harbour Front Avenue, #06-10, Keppel Bay Tower, Singapore 098632
Tel: <65> 6213-0200, Fax: <65> 6278-8001