

IS62WV2568ALL IS62WV2568BLL



256K x 8 LOW VOLTAGE, ULTRA LOW POWER CMOS STATIC RAM

JUNE 2005

FEATURES

- High-speed access time: 55ns, 70ns
- CMOS low power operation
 - 36 mW (typical) operating
 - 9 μ W (typical) CMOS standby
- TTL compatible interface levels
- Single power supply
 - 1.65V--2.2V V_{CC} (62WV2568ALL)
 - 2.5V--3.6V V_{CC} (62WV2568BLL)
- Fully static operation: no clock or refresh required
- Three state outputs
- Industrial temperature available
- Lead-free available

DESCRIPTION

The *ISSI* IS62WV2568ALL / IS62WV2568BLL are high-speed, 2M bit static RAMs organized as 256K words by 8 bits. It is fabricated using *ISSI*'s high-performance CMOS technology. This highly reliable process coupled with innovative circuit design techniques, yields high-performance and low power consumption devices.

When $\overline{CS1}$ is HIGH (deselected) or when CS2 is LOW (deselected) or when $\overline{CS1}$ is LOW, CS2 is HIGH, the device assumes a standby mode at which the power dissipation can be reduced down with CMOS input levels.

Easy memory expansion is provided by using Chip Enable and Output Enable inputs. The active LOW Write Enable (\overline{WE}) controls both writing and reading of the memory.

The IS62WV2568ALL and IS62WV2568BLL are packaged in the JEDEC standard 32-pin TSOP (TYPE I), sTSP (TYPE I), and 36-pin mini BGA.

FUNCTIONAL BLOCK DIAGRAM

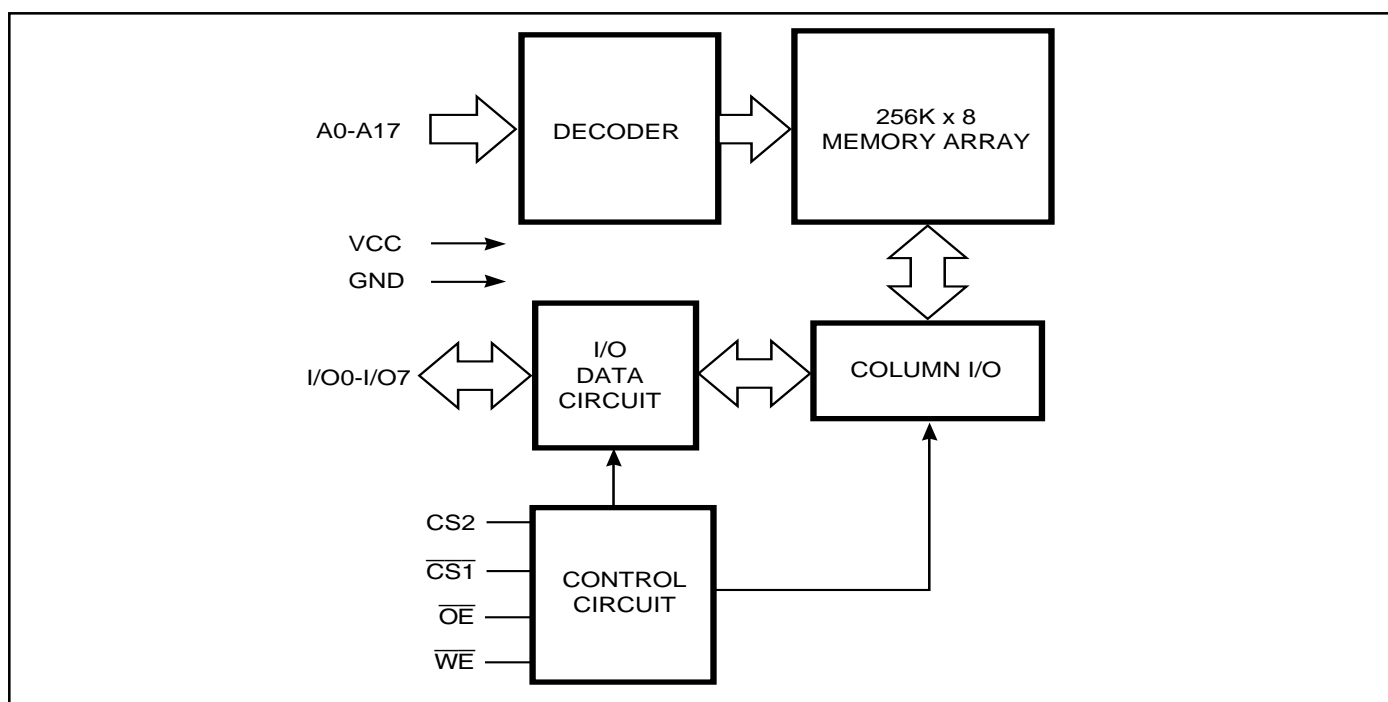

Copyright © 2002 Integrated Silicon Solution, Inc. All rights reserved. ISSI reserves the right to make changes to this specification and its products at any time without notice. ISSI assumes no liability arising out of the application or use of any information, products or services described herein. Customers are advised to obtain the latest version of this device specification before relying on any published information and before placing orders for products.

PIN DESCRIPTIONS

A0-A17	Address Inputs
$\overline{CS1}$	Chip Enable 1 Input
CS2	Chip Enable 2 Input
\overline{OE}	Output Enable Input
\overline{WE}	Write Enable Input
I/O0-I/O7	Input/Output
NC	No Connection
Vcc	Power
GND	Ground

PIN CONFIGURATION

36-pin mini BGA (B) (6mm x 8mm)

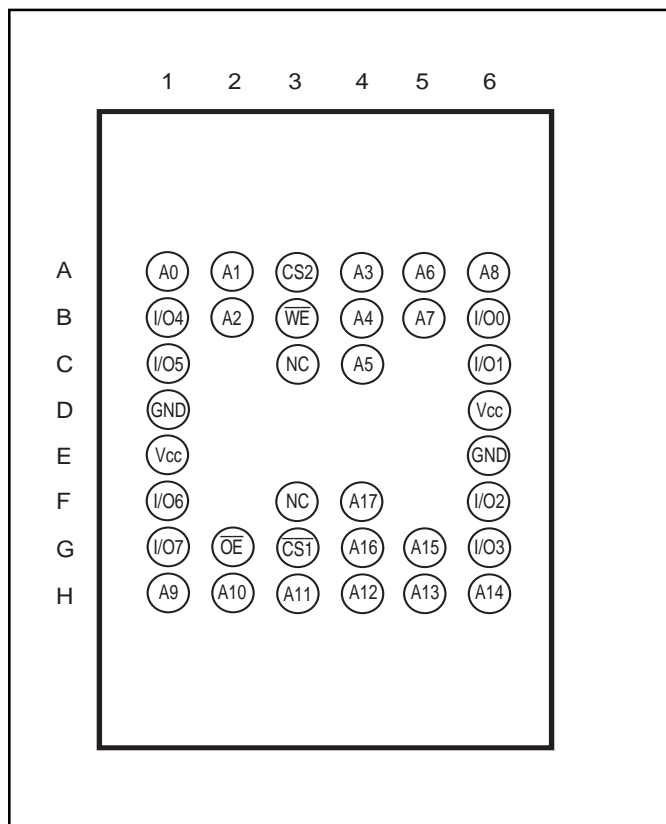

32-pin TSOP (TYPE I), sTSOP (TYPE I)

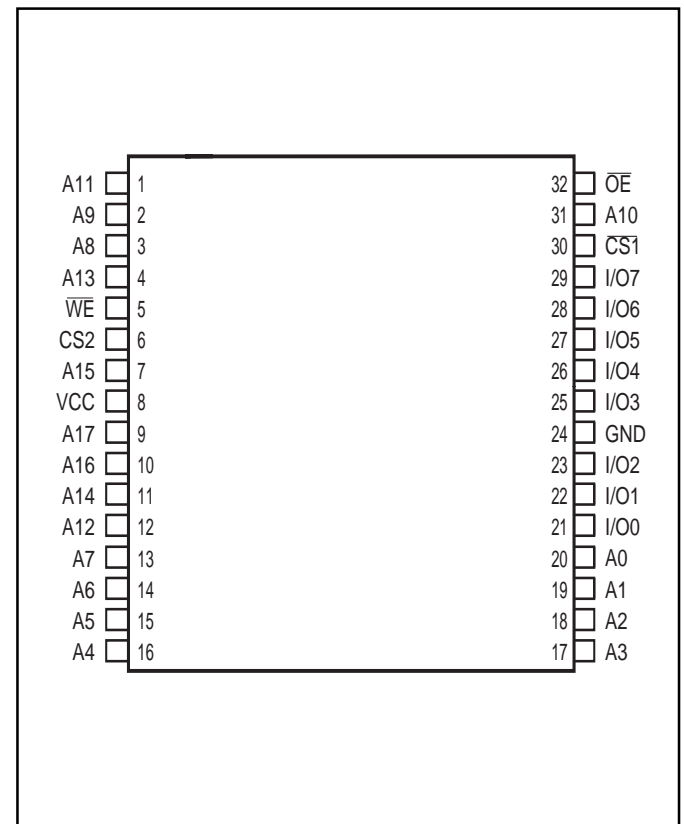

ABSOLUTE MAXIMUM RATINGS⁽¹⁾

Symbol	Parameter	Value	Unit
V _{TERM}	Terminal Voltage with Respect to GND	-0.2 to V _{CC} +0.3	V
T _{STG}	Storage Temperature	-65 to +150	°C
P _T	Power Dissipation	1.0	W

Note:

1. Stress greater than those listed under ABSOLUTE MAXIMUM RATINGS may cause permanent damage to the device. This is a stress rating only and functional operation of the device at these or any other conditions above those indicated in the operational sections of this specification is not implied. Exposure to absolute maximum rating conditions for extended periods may affect reliability.

OPERATING RANGE (V_{CC})

Range	Ambient Temperature	IS62WV2568ALL	IS62WV2568BLL
Commercial	0°C to +70°C	1.65V - 2.2V	2.5V - 3.6V
Industrial	-40°C to +85°C	1.65V - 2.2V	2.5V - 3.6V

DC ELECTRICAL CHARACTERISTICS (Over Operating Range)

Symbol	Parameter	Test Conditions	V _{CC}	Min.	Max.	Unit
V _{OH}	Output HIGH Voltage	I _{OH} = -0.1 mA	1.65-2.2V	1.4	—	V
		I _{OH} = -1 mA	2.5-3.6V	2.2	—	V
V _{OL}	Output LOW Voltage	I _{OL} = 0.1 mA	1.65-2.2V	—	0.2	V
		I _{OL} = 2.1 mA	2.5-3.6V	—	0.4	V
V _{IH}	Input HIGH Voltage		1.65-2.2V	1.4	V _{CC} + 0.2	V
			2.5-3.6V	2.2	V _{CC} + 0.3	V
V _{IL} ⁽¹⁾	Input LOW Voltage		1.65-2.2V	-0.2	0.4	V
			2.5-3.6V	-0.2	0.6	V
I _{LI}	Input Leakage	GND ≤ V _{IN} ≤ V _{CC}		-1	1	μA
I _{LO}	Output Leakage	GND ≤ V _{OUT} ≤ V _{CC} , Outputs Disabled		-1	1	μA

Notes:

1. V_{IL} (min.) = -1.0V for pulse width less than 10 ns.

CAPACITANCE⁽¹⁾

Symbol	Parameter	Conditions	Max.	Unit
C _{IN}	Input Capacitance	V _{IN} = 0V	8	pF
C _{OUT}	Input/Output Capacitance	V _{OUT} = 0V	10	pF

Note:

1. Tested initially and after any design or process changes that may affect these parameters.

AC TEST CONDITIONS

Parameter	62WV2568ALL (Unit)	62WV2568BLL (Unit)
Input Pulse Level	0.4V to V _{CC} -0.2V	0.4V to V _{CC} -0.3V
Input Rise and Fall Times	5 ns	5ns
Input and Output Timing and Reference Level	V _{REF}	V _{REF}
Output Load	See Figures 1 and 2	See Figures 1 and 2

	1.65-2.2V	2.5V - 3.6V
R1(Ω)	3070	3070
R2(Ω)	3150	3150
V _{REF}	0.9V	1.5V
V _{TM}	1.8V	2.8V

AC TEST LOADS

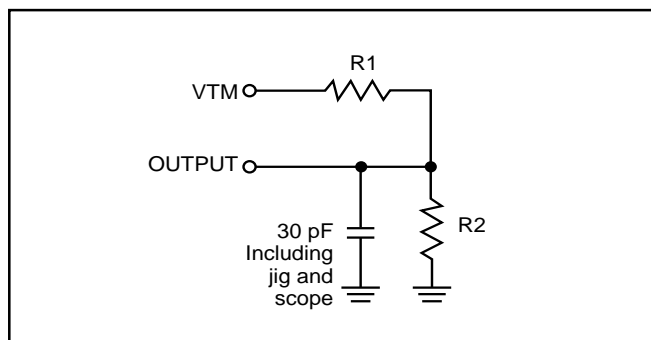

Figure 1

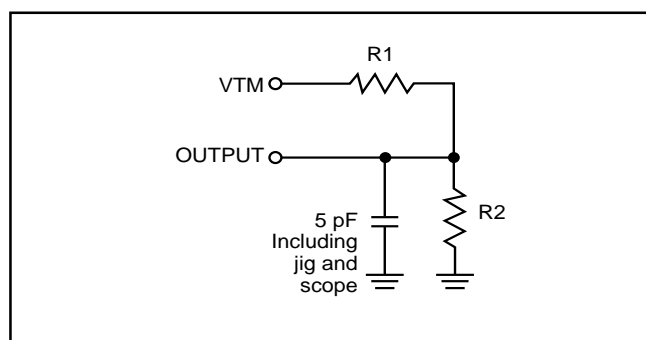

Figure 2

IS62WV2568ALL, IS62WV2568BLL

POWER SUPPLY CHARACTERISTICS⁽¹⁾ (Over Operating Range)

62WV2568ALL (1.65V - 2.2V)

Symbol	Parameter	Test Conditions		Max. 70 ns	Unit
I _{CC}	V _{CC} Dynamic Operating Supply Current	V _{CC} = Max.,	Com.	15	mA
		I _{OUT} = 0 mA, f = f _{MAX}	Ind.	15	
I _{CC1}	Operating Supply Current	V _{CC} = Max.,	Com.	3	mA
		I _{OUT} = 0 mA, f = 0	Ind.	3	
I _{SB1}	TTL Standby Current (TTL Inputs)	V _{CC} = Max.,	Com.	0.3	mA
		V _{IN} = V _{IH} or V _{IL} , CS1 = V _{IH} , CS2 = V _{IL} , f = 1 MHz	Ind.	0.3	
I _{SB2}	CMOS Standby Current (CMOS Inputs)	V _{CC} = Max.,	Com.	5	μA
		CS1 ≥ V _{CC} - 0.2V, CS2 ≤ 0.2V, V _{IN} ≥ V _{CC} - 0.2V, or V _{IN} ≤ 0.2V, f = 0	Ind.	10	

POWER SUPPLY CHARACTERISTICS⁽¹⁾ (Over Operating Range)

62WV2568BLL (2.5V - 3.6V)

Symbol	Parameter	Test Conditions		Max. 55 ns	Max. 70 ns	Unit
I _{CC}	V _{CC} Dynamic Operating Supply Current	V _{CC} = Max.,	Com.	30	25	mA
		I _{OUT} = 0 mA, f = f _{MAX}	Ind.	35	30	
I _{CC1}	Operating Supply Current	V _{CC} = Max.,	Com.	3	3	mA
		I _{OUT} = 0 mA, f = 0	Ind.	3	3	
I _{SB1}	TTL Standby Current (TTL Inputs)	V _{CC} = Max.,	Com.	0.3	0.3	mA
		V _{IN} = V _{IH} or V _{IL} , CS1 = V _{IH} , CS2 = V _{IL} , f = 1 MHz	Ind.	0.3	0.3	
I _{SB2}	CMOS Standby Current (CMOS Inputs)	V _{CC} = Max.,	Com.	10	10	μA
		CS1 ≥ V _{CC} - 0.2V, CS2 ≤ 0.2V, V _{IN} ≥ V _{CC} - 0.2V, or V _{IN} ≤ 0.2V, f = 0	Ind.	10	10	

READ CYCLE SWITCHING CHARACTERISTICS⁽¹⁾ (Over Operating Range)

Symbol	Parameter	55 ns		70 ns		Unit
		Min.	Max.	Min.	Max.	
t _{RC}	Read Cycle Time	55	—	70	—	ns
t _{AA}	Address Access Time	—	55	—	70	ns
t _{OHA}	Output Hold Time	10	—	10	—	ns
t _{ACS1} /t _{ACS2}	$\overline{CS1}$ /CS2 Access Time	—	55	—	70	ns
t _{DOE}	\overline{OE} Access Time	—	25	—	35	ns
t _{HZOE⁽²⁾}	\overline{OE} to High-Z Output	—	20	—	25	ns
t _{LZOE⁽²⁾}	\overline{OE} to Low-Z Output	5	—	5	—	ns
t _{HZCS1} /t _{HZCS2⁽²⁾}	$\overline{CS1}$ /CS2 to High-Z Output	0	20	0	25	ns
t _{LZCS1} /t _{LZCS2⁽²⁾}	$\overline{CS1}$ /CS2 to Low-Z Output	10	—	10	—	ns

Notes:

1. Test conditions assume signal transition times of 5 ns or less, timing reference levels of 0.9V, input pulse levels of 0.4 to 1.4V and output loading specified in Figure 1.
2. Tested with the load in Figure 2. Transition is measured ±500 mV from steady-state voltage. Not 100% tested.

AC WAVEFORMS

READ CYCLE NO. 1^(1,2) (Address Controlled) ($\overline{CS1} = \overline{OE} = V_{IL}$, CS2 = $\overline{WE} = V_{IH}$)

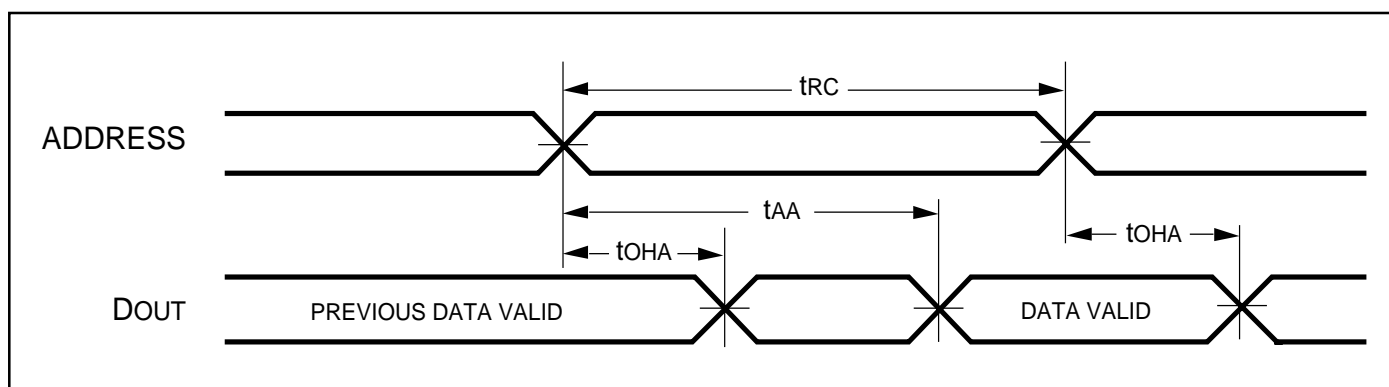

AC WAVEFORMS

READ CYCLE NO. 2^(1,3) ($\overline{CS1}$, CS2, \overline{OE} Controlled)

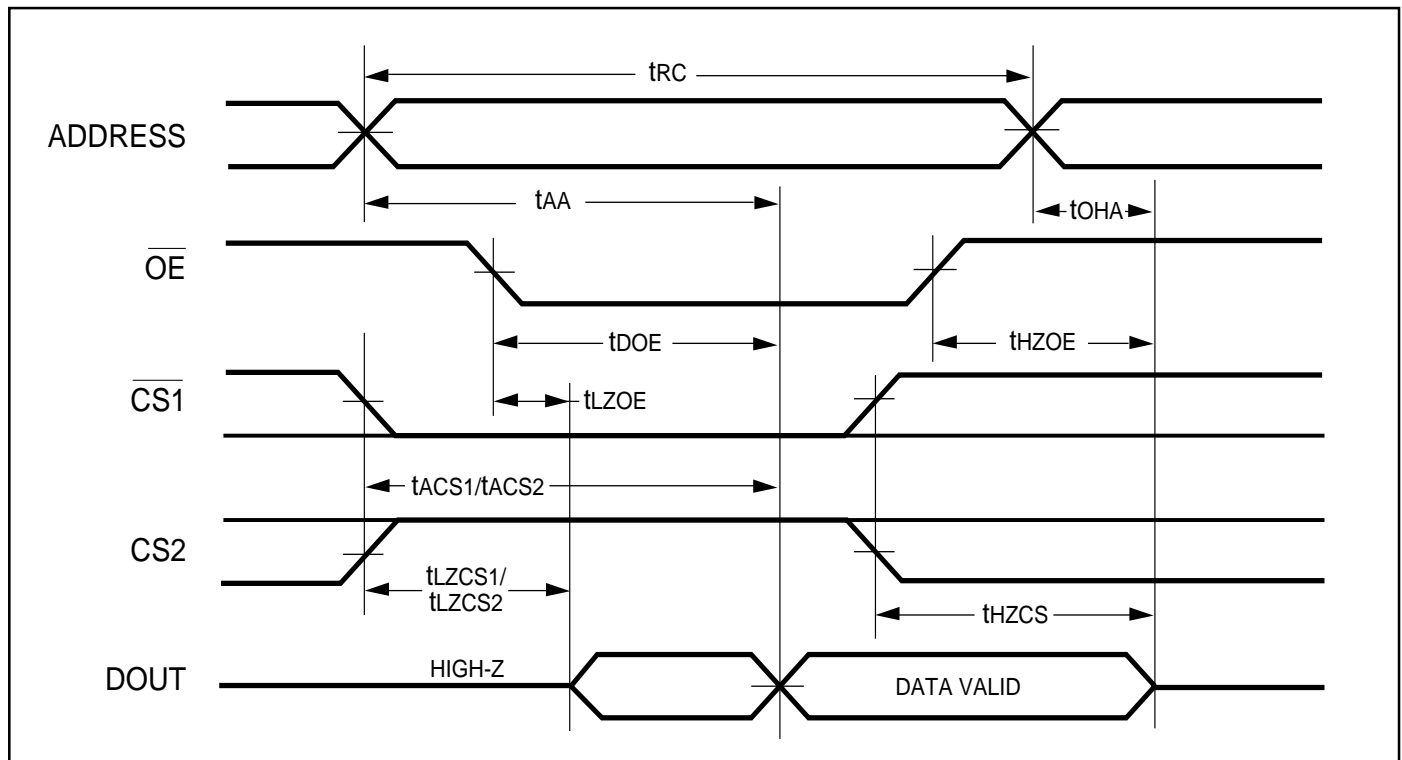

Notes:

1. \overline{WE} is HIGH for a Read Cycle.
2. The device is continuously selected. \overline{OE} , $\overline{CS1} = V_{IL}$. CS2= \overline{WE} = V_{IH} .
3. Address is valid prior to or coincident with $\overline{CS1}$ LOW and CS2 HIGH transition.

WRITE CYCLE SWITCHING CHARACTERISTICS^(1,2) (Over Operating Range)

Symbol	Parameter	55 ns		70 ns		Unit
		Min.	Max.	Min.	Max.	
t _{WC}	Write Cycle Time	55	—	70	—	ns
t _{SCS1} /t _{SCS2}	$\overline{CS1}$ /CS2 to Write End	45	—	60	—	ns
t _{AW}	Address Setup Time to Write End	45	—	60	—	ns
t _{HA}	Address Hold from Write End	0	—	0	—	ns
t _{SA}	Address Setup Time	0	—	0	—	ns
t _{PWE}	\overline{WE} Pulse Width	40	—	50	—	ns
t _{SD}	Data Setup to Write End	25	—	30	—	ns
t _{HD}	Data Hold from Write End	0	—	0	—	ns
t _{HZWE⁽³⁾}	\overline{WE} LOW to High-Z Output	—	20	—	20	ns
t _{LZWE⁽³⁾}	\overline{WE} HIGH to Low-Z Output	5	—	5	—	ns

Notes:

1. Test conditions assume signal transition times of 5 ns or less, timing reference levels of 0.9V, input pulse levels of 0.4V to 1.4V and output loading specified in Figure 1.
2. The internal write time is defined by the overlap of $\overline{CS1}$ LOW, CS2 HIGH and \overline{WE} LOW. All signals must be in valid states to initiate a Write, but any one can go inactive to terminate the Write. The Data Input Setup and Hold timing are referenced to the rising or falling edge of the signal that terminates the write.
3. Tested with the load in Figure 2. Transition is measured ± 500 mV from steady-state voltage. Not 100% tested.

AC WAVEFORMS

WRITE CYCLE NO. 1 ($\overline{CS1}$ /CS2 Controlled, \overline{OE} = HIGH or LOW)

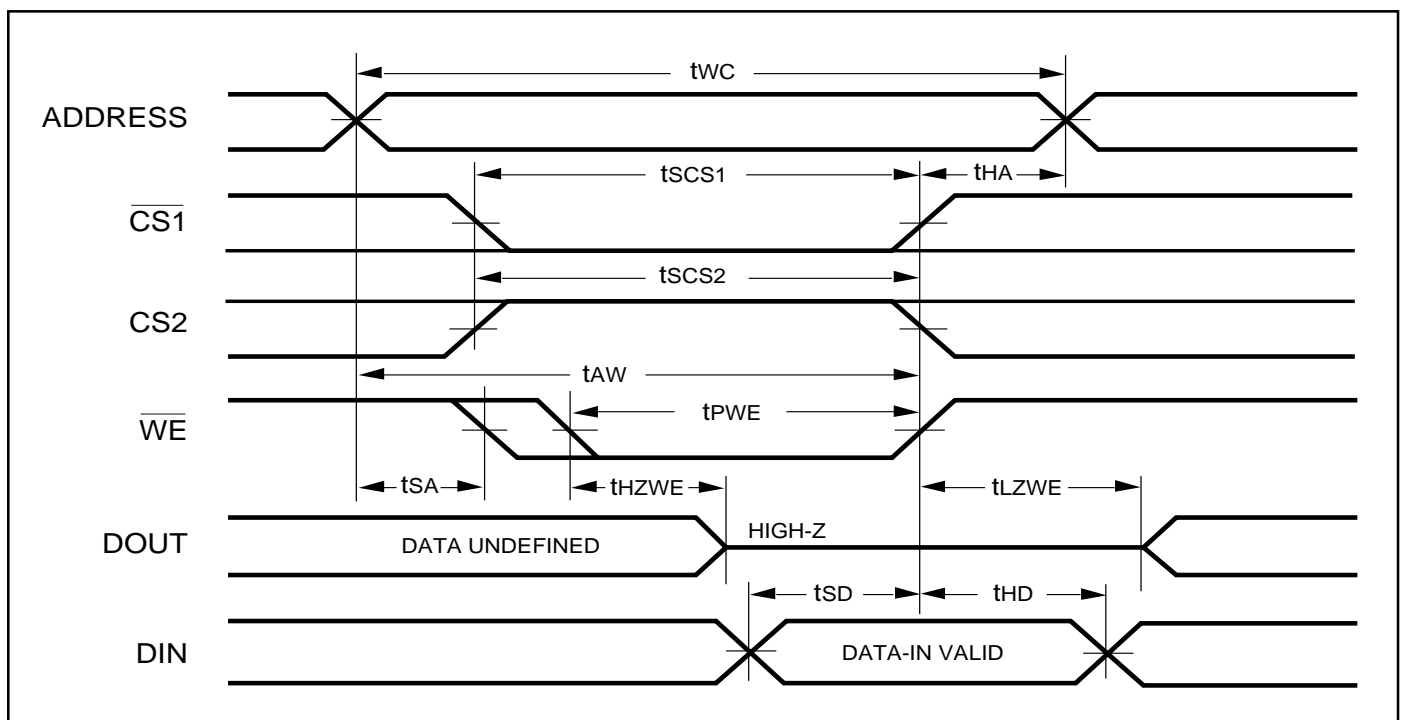

AC WAVEFORMS

WRITE CYCLE NO. 2 (\overline{WE} Controlled: \overline{OE} is HIGH During Write Cycle)

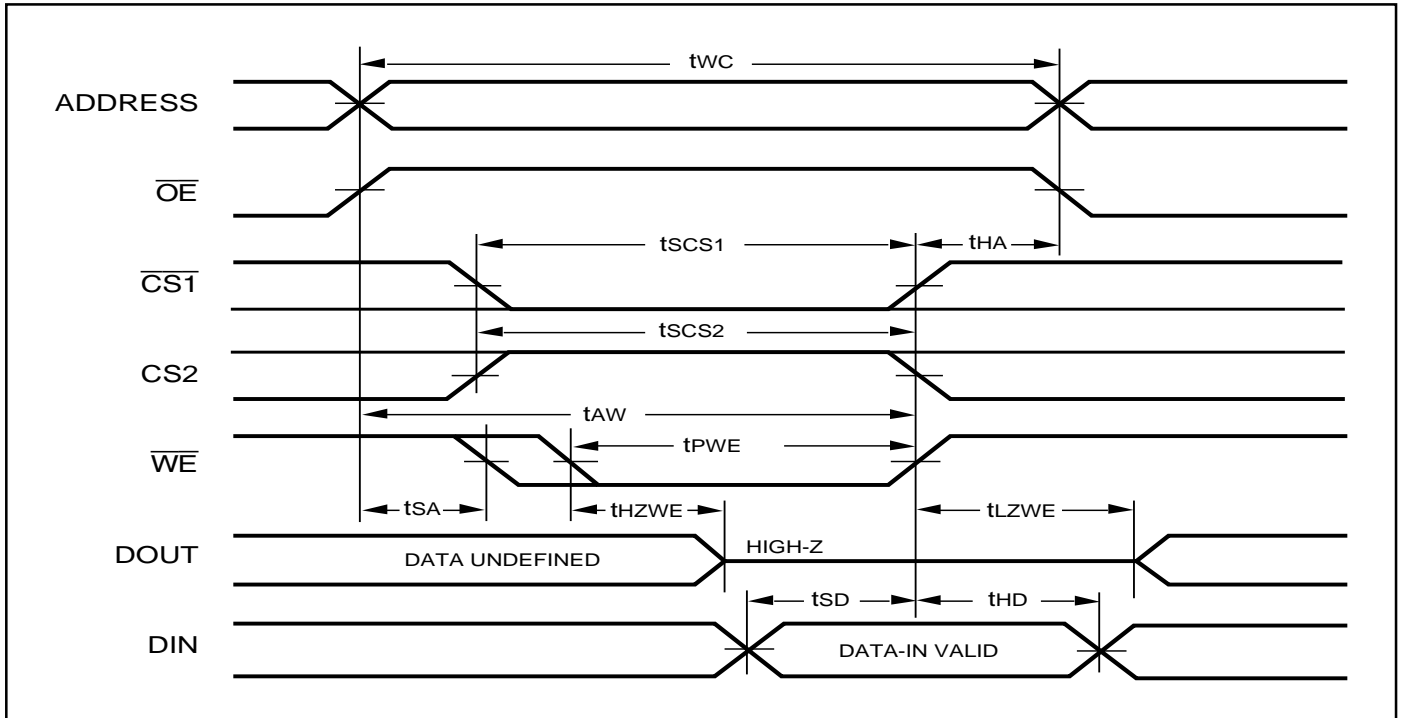

WRITE CYCLE NO. 3 (\overline{WE} Controlled: \overline{OE} is LOW During Write Cycle)

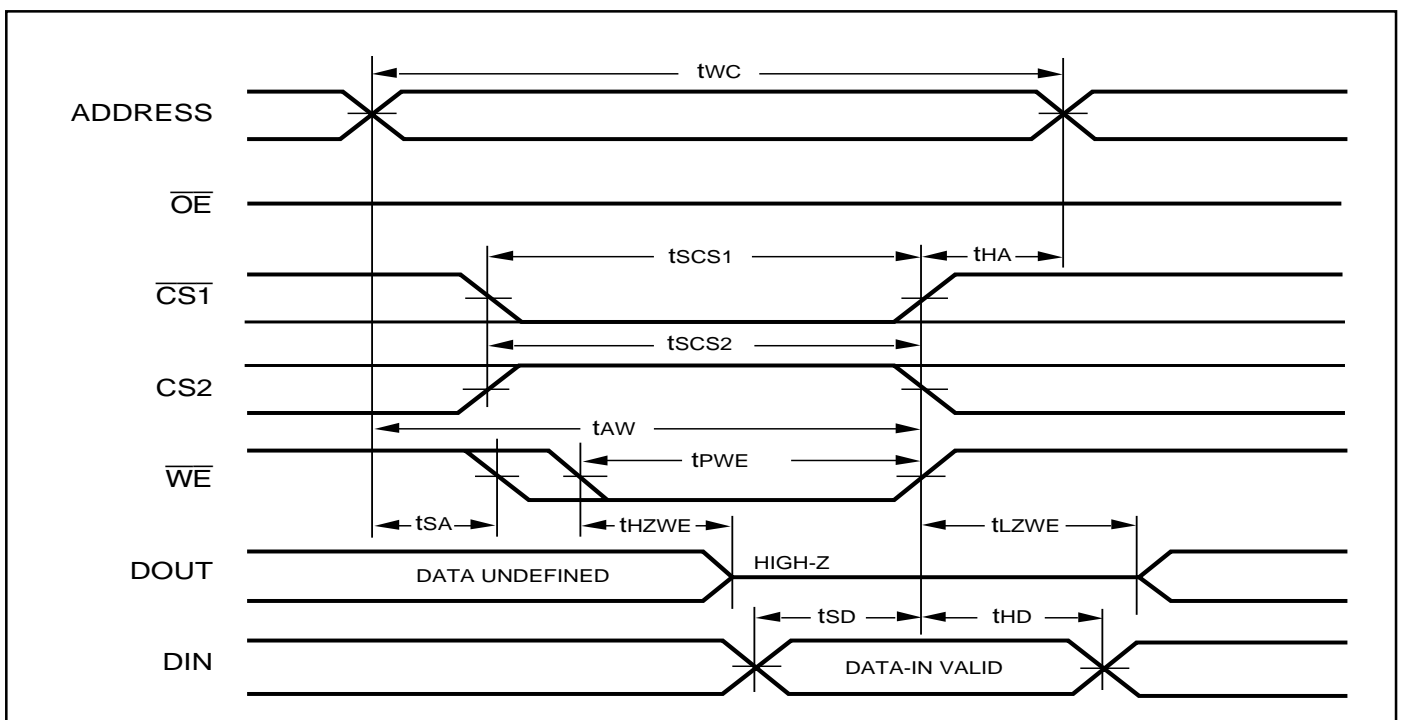

DATA RETENTION SWITCHING CHARACTERISTICS

Symbol	Parameter	Test Condition	Min.	Max.	Unit
V _{DR}	V _{CC} for Data Retention	See Data Retention Waveform	1.0	3.6	V
I _{DR}	Data Retention Current	V _{CC} = 1.0V, $\overline{CS1}/CS2 \geq V_{CC} - 0.2V$	—	10	μA
t _{SDR}	Data Retention Setup Time	See Data Retention Waveform	0	—	ns
t _{RDR}	Recovery Time	See Data Retention Waveform	t _{RC}	—	ns

DATA RETENTION WAVEFORM ($\overline{CS1}$ Controlled)

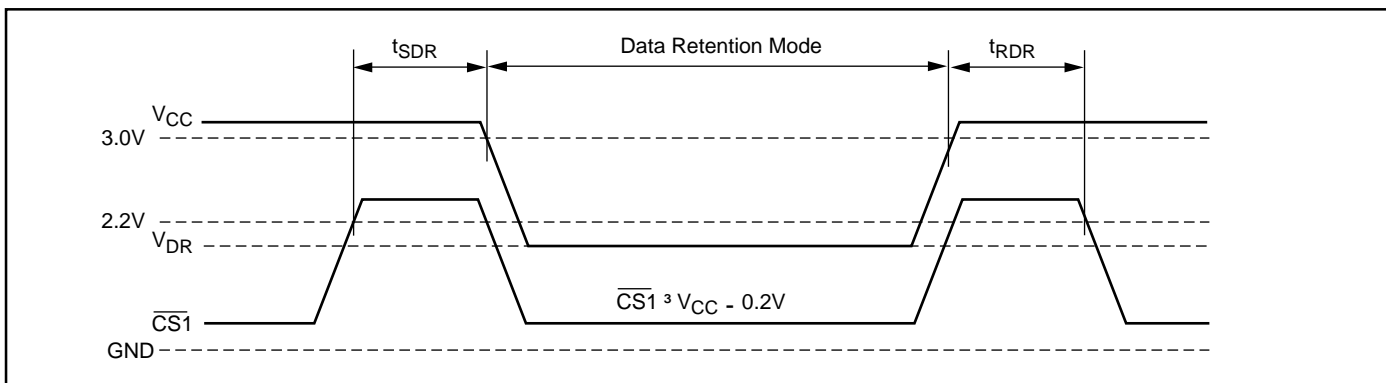

DATA RETENTION WAVEFORM (CS2 Controlled)

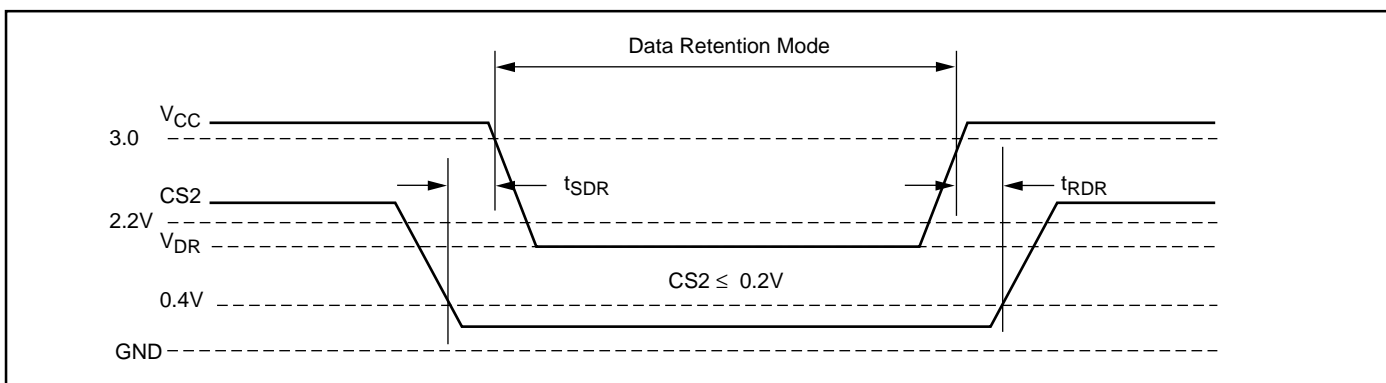

PLASTIC sTSOP - 32 PINS

Package Code: H (Type 1)

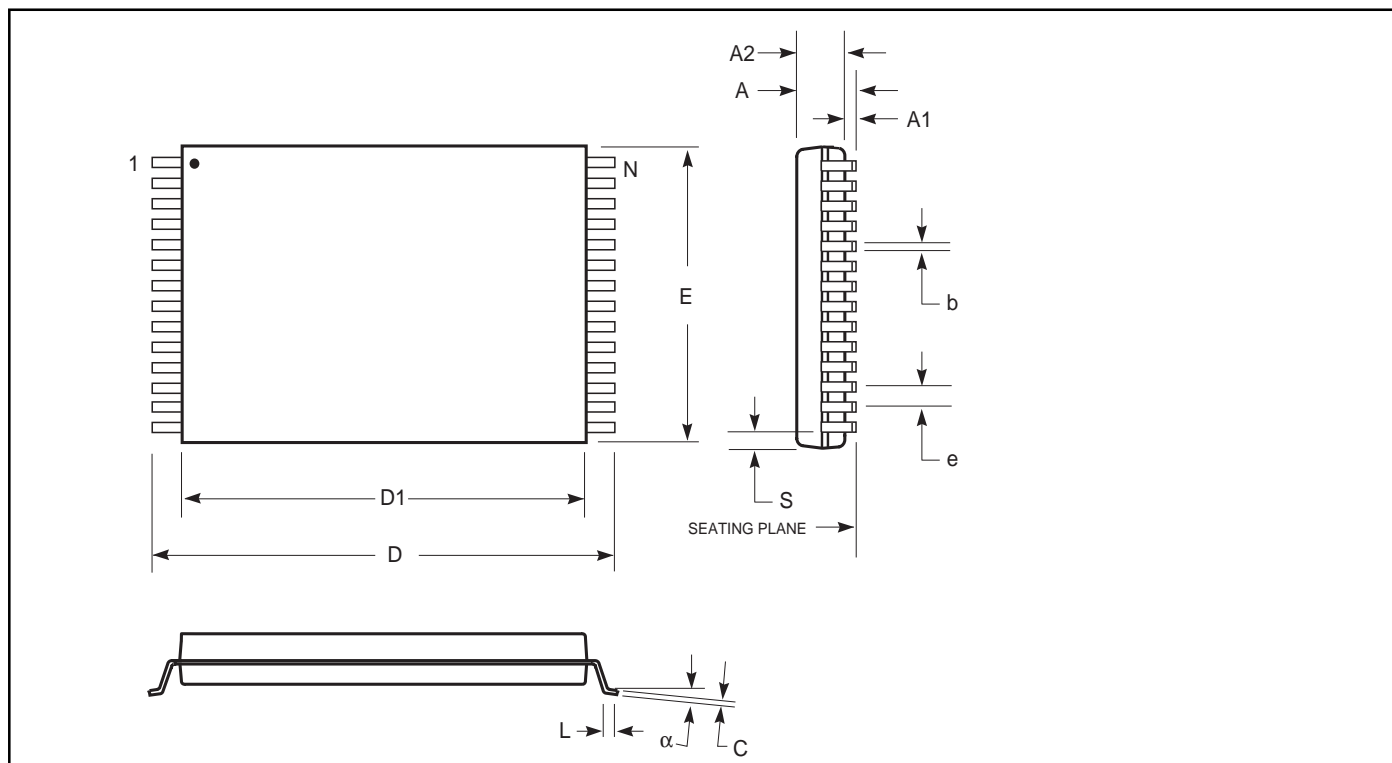

PLASTIC sTSOP (H-TYPE 1)

Symbol	MILLIMETERS		INCHES	
	Min.	Max.	Min.	Max.
REF. STD				
N0. Leads	32			
A	—	1.25	—	0.049
A1	0.05	—	0.002	—
A2	0.95	1.05	0.037	0.041
b	0.17	0.23	0.007	0.009
C	0.142	0.158	0.0056	0.0082
D	13.2	13.6	0.520	0.535
D1	11.7	11.9	0.461	0.469
E	7.9	8.1	0.311	0.319
e	0.50	BSC	0.020	BSC
L	0.30	0.70	0.012	0.028
S	0.278	TYP.	0.0109	TYP.
α	0°	5°	0°	5°

Notes:

1. Controlling dimension: millimeters, unless otherwise specified.
2. BSC=Basic lead spacing between centers.
3. Dimensions D1 and E do not include mold flash protrusion and should be measured from the bottom of the package.
4. Formed leads shall be planar with respect to one another within 0.004 inches at the seating plane.

PLASTIC TSOP - 32 PINS
Package Code: T (Type 1)

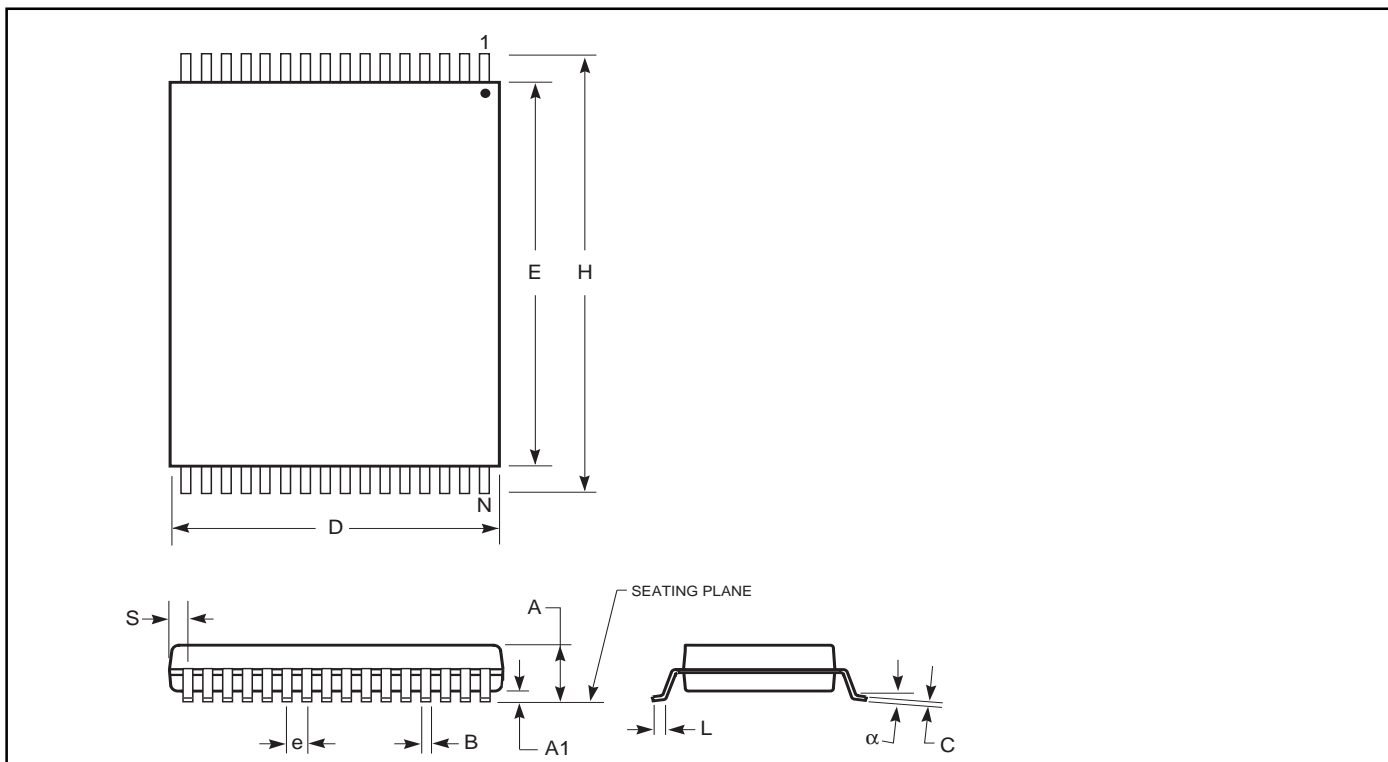

PLASTIC TSOP (T-TYPE 1)

Symbol	MILLIMETERS		INCHES	
	Min.	Max.	Min.	Max.
REF. STD				
N0. Leads	32			
A	—	1.20	—	0.047
A1	0.05	0.25	0.002	0.010
B	0.17	0.23	0.007	0.009
C	0.12	0.17	0.006	0.014
D	7.90	8.10	0.308	0.316
E	18.30	18.50	0.714	0.722
H	19.80	20.20	0.722	0.788
e	0.50	BSC	0.020	BSC
L	0.40	0.60	0.016	0.024
α	0°	8°	0°	8°

Notes:

1. Controlling dimension: millimeters, unless otherwise specified.
2. BSC = Basic lead spacing between centers.
3. Dimensions D1 and E do not include mold flash protrusion and should be measured from the bottom of the package.
4. Formed leads shall be planar with respect to one another within 0.004 inches at the seating plane.

Mini Ball Grid Array

Package Code: B (36-pin) (6mm x 8mm, 8mm x 10 mm)

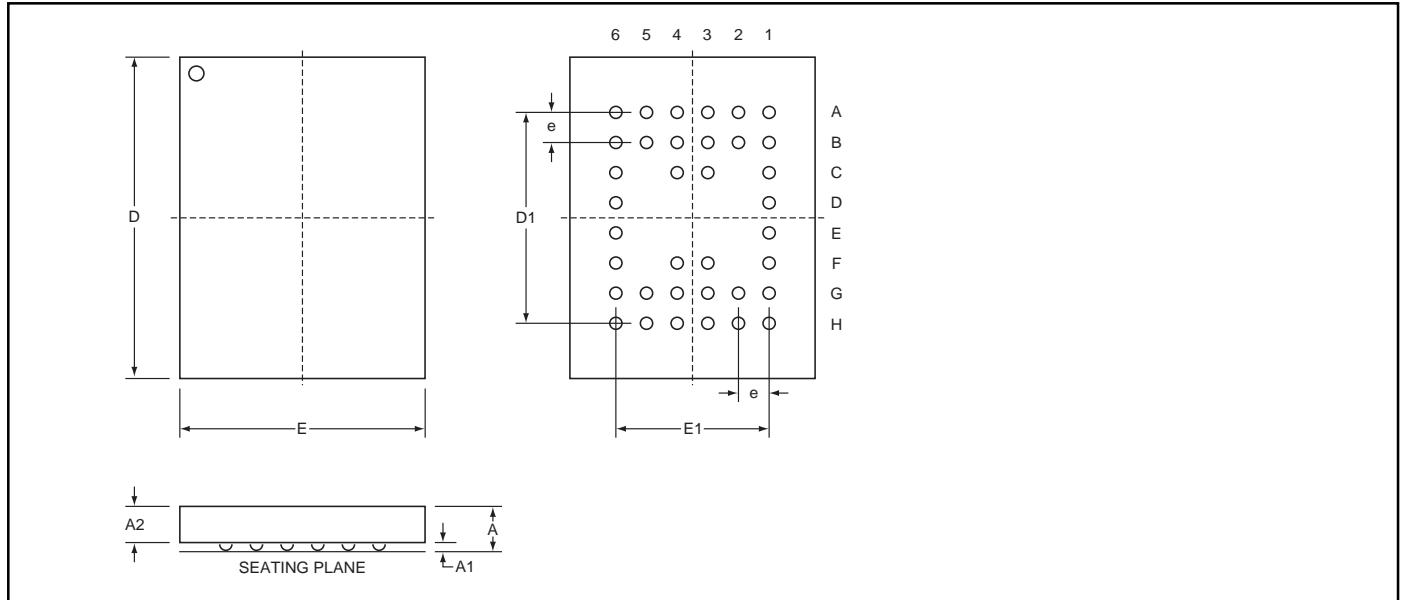

Notes:

1. Controlling dimension: millimeters, unless otherwise specified.
2. BSC = Basic lead spacing between centers.
3. Dimensions D1 and E do not include mold flash protrusion and should be measured from the bottom of the package.
4. Formed leads shall be planar with respect to one another within 0.004 inches at the seating plane.

Mini Ball Grid Array - 6mm x 8mm

	MILLIMETERS			INCHES		
Sym.	Min.	Typ.	Max.	Min.	Typ.	Max.
REF. STD						
N0. Leads	36					
A	1.00	—	1.35	.039	—	.053
A1	0.24	—	.030	.009	—	.011
A2	.600	—	—	.023	—	—
D	7.90	8.00	8.10	.311	.314	.318
D1	5.25BSC			.206BSC		
E	5.90	6.00	6.10	.232	.236	.240
E1	3.75BSC			.147BSC		
e	0.75BSC			.029BSC		

Mini Ball Grid Array - 8mm x 10mm

	MILLIMETER			INCHES		
Sym.	Min.	Typ.	Max.	Min.	Typ.	Max.
REF. STD						
N0. Leads	36					
A	1.00	—	1.35	.039	—	.053
A1	0.24	—	0.030	.009	—	.011
A2	.600	—	—	.023	—	—
D	9.90	10.00	10.10	.389	.393	.397
D1	5.25BSC			.206BSC		
E	7.90	8.00	8.10	.311	.314	.318
E1	3.75BSC			.147BSC		
e	0.75BSC			.029BSC		

ORDERING INFORMATION

IS62WV2568ALL (1.65V - 2.2V)

Commercial Range: 0°C to +70°C

Speed (ns)	Order Part No.	Package
70	IS62WV2568ALL-70T	TSOP, TYPE I,

Industrial Range: -40°C to +85°C

Speed (ns)	Order Part No.	Package
70	IS62WV2568ALL-70TI	TSOP, TYPE I
70	IS62WV2568ALL-70BI	mini BGA (6mm x 8mm)
70	IS62WV2568ALL-70HI	sTSOP, TYPE I

IS62WV2568BLL (2.5V - 3.6V)

Commercial Range: 0°C to +70°C

Speed (ns)	Order Part No.	Package
70	IS62WV2568BLL-70T	TSOP, TYPE I
70	IS62WV2568BLL-70B	mini BGA (6mm x 8mm)
70	IS62WV2568BLL-70H	sTSOP, TYPE I

Industrial Range: -40°C to +85°C

Speed (ns)	Order Part No.	Package
55	IS62WV2568BLL-55TI	TSOP, TYPE I
55	IS62WV2568BLL-55TLI	TSOP, TYPE I, Lead-free
55	IS62WV2568BLL-55BI	mini BGA (6mm x 8mm)
55	IS62WV2568BLL-55BLI	mini BGA (6mm x 8mm), Lead-free
55	IS62WV2568BLL-55HI	sTSOP, TYPE I
55	IS62WV2568BLL-55HLI	sTSOP, TYPE I, Lead-free
70	IS62WV2568BLL-70TI	TSOP, TYPE I
70	IS62WV2568BLL-70BI	mini BGA (6mm x 8mm)
70	IS62WV2568BLL-70HI	sTSOP, TYPE I