



UZ2085

Preliminary

LINEAR INTEGRATED CIRCUIT

3A ADJUSTABLE/FIXED LOW DROPOUT LINEAR REGULATOR

DESCRIPTION

The UTC **UZ2085-xx** series are low dropout three-terminal regulators with 3A output current capability. These devices have been optimized for low voltage applications including VTT bus termination in which transient response and minimum input voltage are critical.

Current limit is trimmed to ensure specified output current and controlled short-circuit current. On-chip thermal limitation provides protection against any combination of overload and ambient temperature that would create excessive junction temperature.

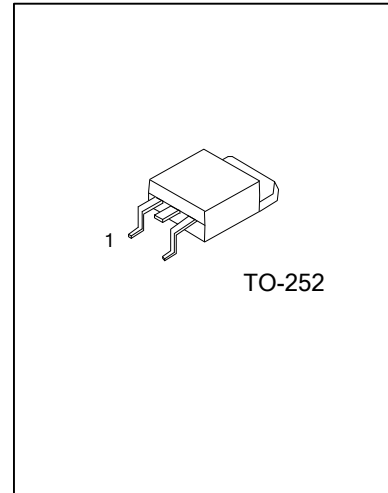

FEATURES

- * Fast transient response
- * Low dropout voltage at up to 3A
- * Load regulation: 0.05% typical
- * Trimmed current limit
- * On-chip thermal limiting
- * Ultra low current consumption (0.35mA typ.)
- * Ultra low Adjustment Current (7µA typ.)
- * Ultra low minimum Load (0.3mA typ.)
- * Support MLCC

ORDERING INFORMATION

Ordering Number		Package	Pin Assignment			Packing
Lead Free	Halogen Free		1	2	3	
UZ2085L-xx-TN3-R	UZ2085G-xx-TN3-R	TO-252	A/G	O	I	Tape Reel

Note: 1. xx: Output Voltage, refer to Marking Information.

2. A: ADJ (for adjustable regulator), G: GND (for fixed regulator), O: V_{OUT} , I: V_{IN}

<p>UZ2085L-xx-TN3-R</p> <ul style="list-style-type: none"> (1) Packing Type (2) Package Type (3) Output Voltage Code (4) Lead Free 	<ul style="list-style-type: none"> (1) R: Tape Reel (2) TN3: TO-252 (3) xx: Refer to Marking Information (4) G: Halogen Free, L: Lead Free
--	--

■ MARKING INFORMATION

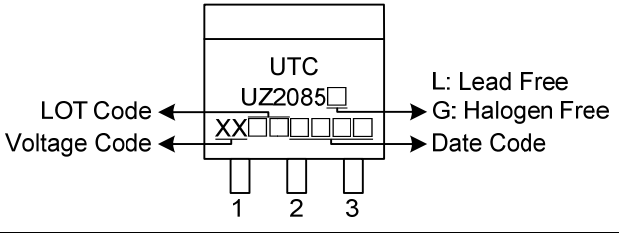
PACKAGE	VOLTAGE CODE	MARKING
TO-252	50 :5.0V AD:ADJ	

■ ABSOLUTE MAXIMUM RATINGS

PARAMETER	SYMBOL	RATINGS	UNIT
Input Voltage	V_{IN}	18	V
Power Dissipation	P_D	Internally Limited	W
Junction Temperature	T_J	+150	°C
Operating Temperature	T_{OPR}	-20 ~ +85	°C
Storage Temperature	T_{STG}	-40 ~ +150	°C

Note:1 Absolute maximum ratings are those values beyond which the device could be permanently damaged. Absolute maximum ratings are stress ratings only and functional device operation is not implied.

■ THERMAL DATA

PARAMETER	SYMBOL	RATINGS	UNIT
Junction to Ambient	θ_{JA}	118	°C/W
Junction to Case	θ_{JC}	12	°C/W

■ ELECTRICAL CHARACTERISTICS ($T_A=25^\circ\text{C}$, $C_{OUT}=22\mu\text{F}$, unless otherwise specified.)

For UZ2085-ADJ (Adjustable)

PARAMETER	SYMBOL	TEST CONDITIONS	MIN.	TYP.	MAX.	UNIT
Reference Voltage	V_{REF}	$1.5V \leq (V_{IN} - V_{OUT}) \leq 8.25V$ $10mA \leq I_{OUT} \leq 3A$	1.237	1.25	1.263	V
Line Regulation	ΔV_{OUT}	$(V_{OUT} + 1.5V) \leq V_{IN} \leq 12V$, $I_{OUT} = 10mA$		0.005	0.2	%
Load Regulation	ΔV_{OUT}	$(V_{IN} - V_{OUT}) = 3V$, $10mA \leq I_{OUT} \leq 3A$		0.05	0.5	%
Dropout Voltage	V_D	$\Delta V_{REF} \% = 1\%$, $I_{OUT} = 3A$		1.2	1.40	V
Current Limit	I_{LIMIT}	$(V_{IN} - V_{OUT}) = 2V$	3.1	5.8		A
Adjust Pin Current	I_{adj}			7	10	μA
Adjust Pin Current Change	ΔI_{adj}	$(V_{OUT} + 1.5V) \leq V_{IN} \leq 12V$ $10mA \leq I_{OUT} \leq 3A$		0.3	2	μA
Minimum Load Current	$I_{O(MIN)}$	$(V_{OUT} + 1.5V) \leq V_{IN} \leq 12V$		0.3	1	mA
Ripple Rejection	RR	$f = 120\text{Hz}$, Tantalum, $(V_{IN} - V_{OUT}) = 3V$ $I_{OUT} = 3A$	75			dB
Thermal Regulation		$T_A = 25^\circ\text{C}$, 30ms pulse		0.004	0.02	%/W
Temperature Stability	ΔV_{OUT}			0.5		%
Long-Term Stability	ΔV_{OUT}	$T_A = 125^\circ\text{C}$, 1000hr		0.03	1.0	%
Output Noise(% of V_{OUT})	e_N	$T_A = 25^\circ\text{C}$, $10\text{Hz} \leq f \leq 10\text{kHz}$		0.003		%
Thermal Shutdown				150		°C

■ ELECTRICAL CHARACTERISTICS(Cont.)

For UZ2085-xx (Fixed Voltage)

PARAMETER	SYMBOL	TEST CONDITIONS	MIN.	TYP.	MAX.	UNIT
Output Voltage	UZ1085-50 V_{OUT}	$6.5V \leq V_{IN} \leq 12V, 10mA \leq I_{OUT} \leq 3A$	4.950	5.0	5.050	V
Line Regulation	ΔV_{OUT}	$(V_{OUT} + 1.5V) \leq V_{IN} \leq 12V, I_{OUT} = 10mA$		0.005	0.2	%
Load Regulation	ΔV_{OUT}	$(V_{IN} - V_{OUT}) = 3V, 10mA \leq I_{OUT} \leq 3A$		0.05	0.5	%
Dropout Voltage	V_D	$\Delta V_{REF} \% = 1\%, I_{OUT} = 3A$		1.2	1.40	V
Current Limit	I_{LIMIT}	$(V_{IN} - V_{OUT}) = 2V$	3.1	5.8		A
Minimum Load Current	$I_{O(MIN)}$	$(V_{OUT} + 1.5V) \leq V_{IN} \leq 12V$			1	mA
Quiescent Current	I_Q	$V_{IN} = 12V$		0.35	0.5	mA
Ripple Rejection	RR	$f = 120Hz$, Tantalum $(V_{IN} - V_{OUT}) = 3V, I_{OUT} = 3A$	75			dB
Thermal Regulation		$T_A = 25^\circ C, 30ms$ pulse		0.004	0.02	%/W
Temperature Stability	ΔV_{OUT}	$T_A = 125^\circ C, 1000hr$		0.5		%
Long-Term Stability	ΔV_{OUT}			0.03	1.0	%
Output Noise(% of V_{OUT})	e_N	$T_A = 25^\circ C, 10Hz \leq f \leq 10kHz$		0.003		%
Thermal shutdown				150		$^\circ C$

■ TYPICAL APPLICATION CIRCUIT

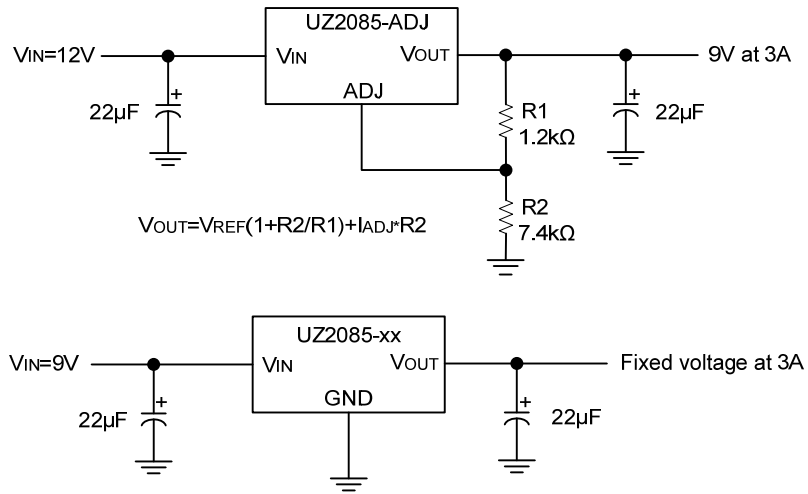

■ TYPICAL CHARACTERISTICS

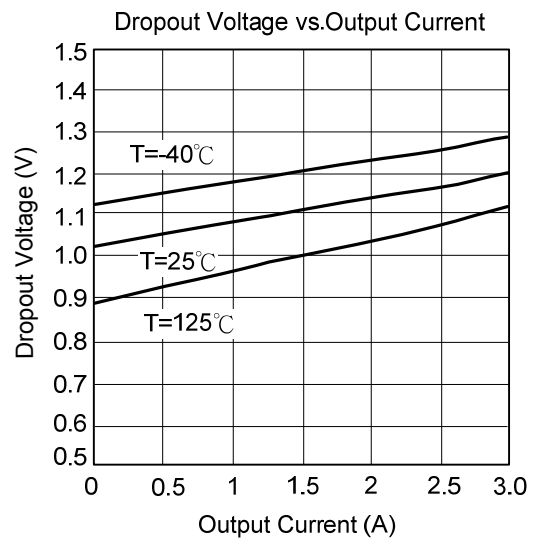
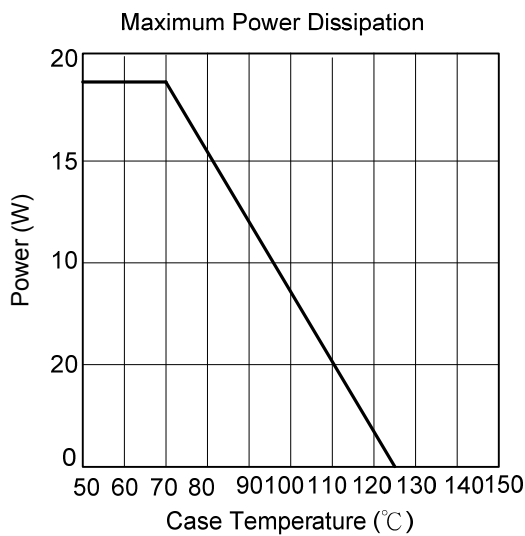
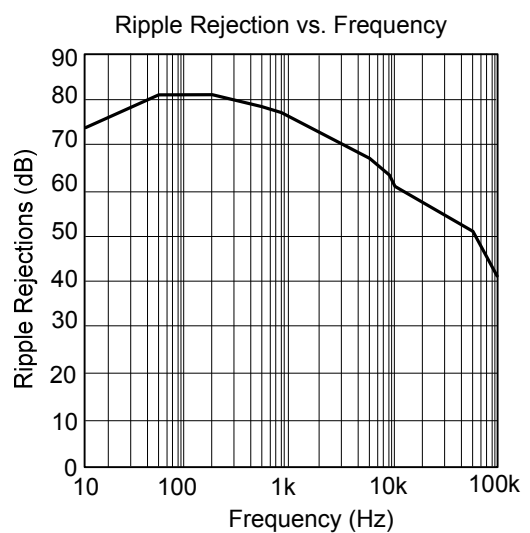
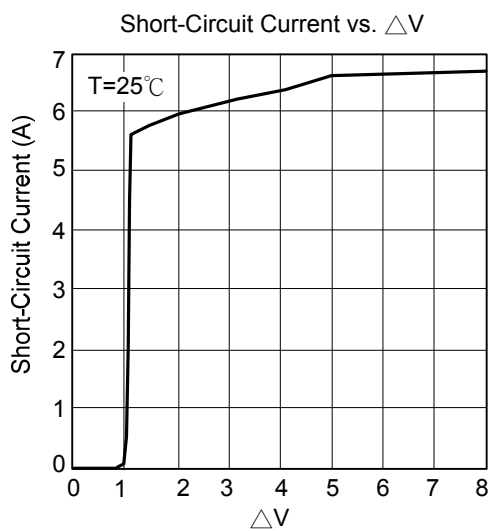
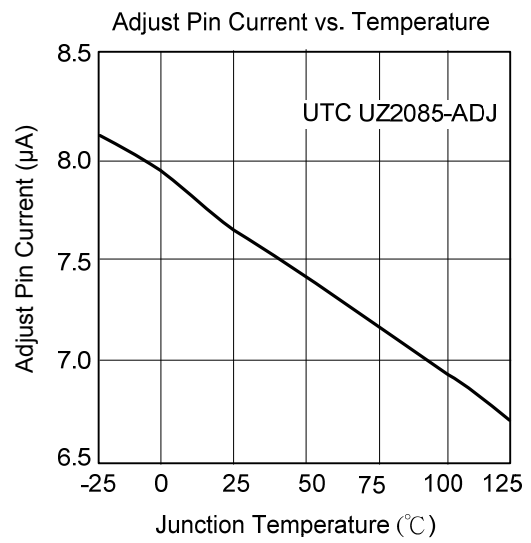
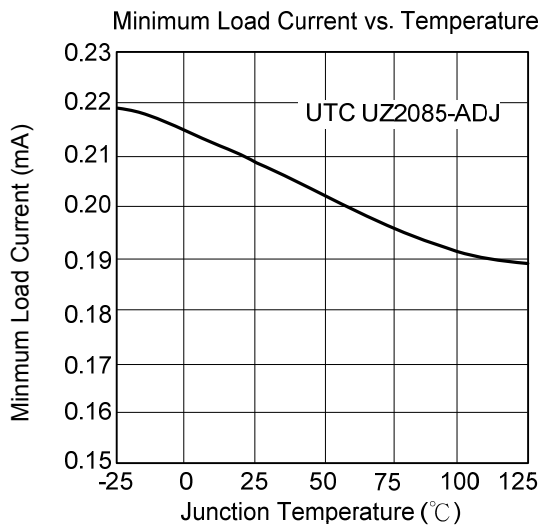

■ TYPICAL CHARACTERISTICS(Cont.)

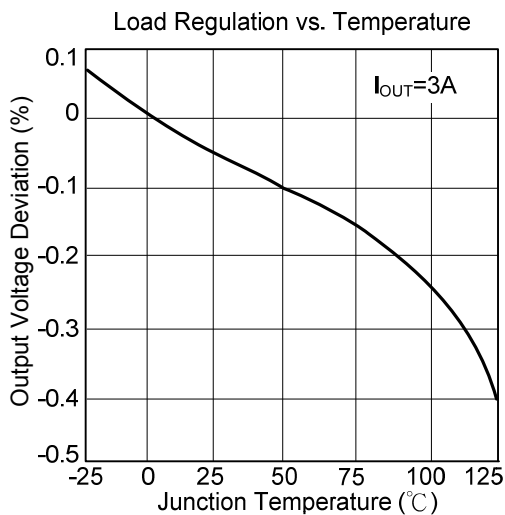
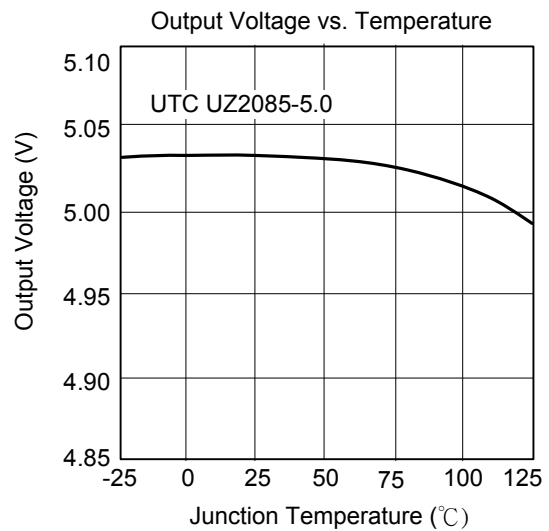
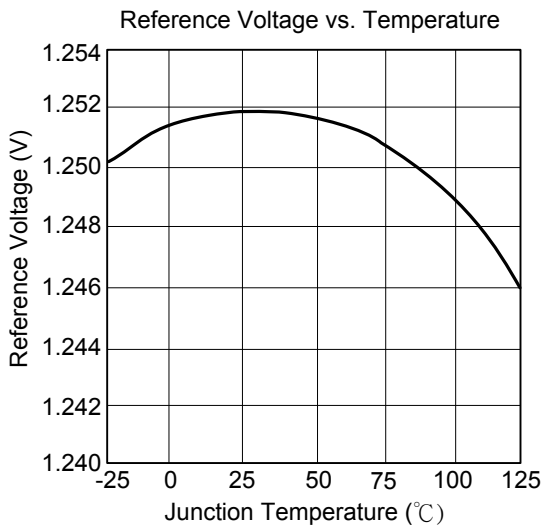
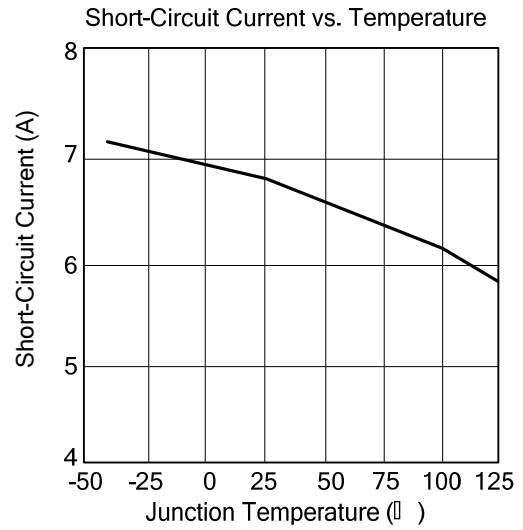
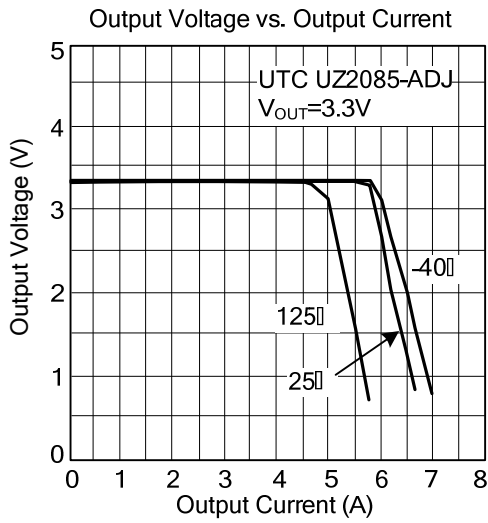

UTC assumes no responsibility for equipment failures that result from using products at values that exceed, even momentarily, rated values (such as maximum ratings, operating condition ranges, or other parameters) listed in products specifications of any and all UTC products described or contained herein. UTC products are not designed for use in life support appliances, devices or systems where malfunction of these products can be reasonably expected to result in personal injury. Reproduction in whole or in part is prohibited without the prior written consent of the copyright owner. The information presented in this document does not form part of any quotation or contract, is believed to be accurate and reliable and may be changed without notice.