

63S440

# High Performance 1024x4 PROM TiW PROM Family

# 53/63S440 53/63S441 53/63S441A

3

## Features/Benefits

- 35-ns maximum access time
- Reliable titanium-tungsten fuses (TiW) guarantee greater than 98% programming yields
- Low-voltage generic programming
- PNP inputs for low input current
- Open collector or three-state outputs

## Applications

- Microprogram control stores
- Microprocessor program store
- Look-up table
- Character generator
- Code converter
- Programmable logic element (PLE™) 10 inputs, 4 outputs, 1024 product terms

## Description

The 53/63S440 and 53/63S441/A are 1024x4 bipolar PROMs featuring low input current PNP inputs, full Schottky clamping with open collector or three-state outputs. The titanium-tungsten fuses store a logical low and are programmed to the high-state. Special on-chip circuitry and extra fuses provide preprogramming testing which assures high programming yields and high reliability.

The 63 series is specified for operation over the commercial temperature and voltage range. The 53 series is specified for the military ranges.

## Programming

The 53/63S440 and 53/63S441/A PROMs are programmed with the same programming algorithm as all other Monolithic Memories' generic TiW PROMs. For details contact the factory.

## Selection Guide

MEMORY			PACKAGE		PERFORMANCE	PART NUMBER	
SIZE	ORGANIZATION	OUTPUT	PINS	TYPE		0°C to +75°C	-55°C to +125°C
4 K	1024x4	TS	18 (20)	N,J,W, (NL),(L)	Enhanced	63S441A	53S441A
		TS				63S441	53S441
		OC			Standard	63S440	53S440

## Pin Configuration

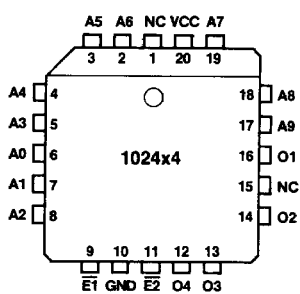
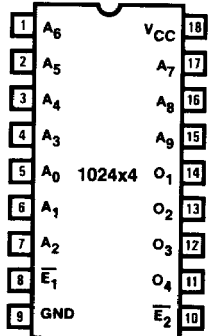

Plastic Chip Carrier

## Block Diagram

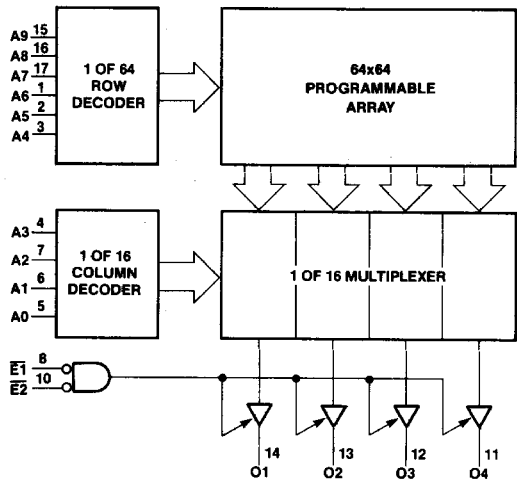

**Absolute Maximum Ratings**

	Operating	Programming
Supply voltage $V_{CC}$ .....	-0.5 V to 7 V	12 V
Input voltage .....	-1.5 V to 7 V	7 V
Input current .....	-30 mA to +5 mA	
Off-state output voltage .....	-0.5 V to 5.5 V	12 V
Storage temperature .....	-65° to +150°C	

**Operating Conditions**

SYMBOL	PARAMETER	MILITARY			COMMERCIAL			UNIT
		MIN	NOM	MAX	MIN	NOM	MAX	
$V_{CC}$	Supply voltage	4.5	5	5.5	4.75	5	5.25	V
$T_A$	Operating free-air temperature	-55		125	0		75	°C

**Electrical Characteristics Over Operating Conditions**

SYMBOL	PARAMETER	TEST CONDITION		MIN	TYP†	MAX	UNIT		
$V_{IL}$	Low-level input voltage					0.8	V		
$V_{IH}$	High-level input voltage			2			V		
$V_{IC}$	Input clamp voltage	$V_{CC} = \text{MIN}$	$I_I = -18 \text{ mA}$			-1.5	V		
$I_{IL}$	Low-level input current	$V_{CC} = \text{MAX}$	$V_I = 0.4 \text{ V}$			-0.25	mA		
$I_{IH}$	High-level input current	$V_{CC} = \text{MAX}$	$V_I = V_{CC} \text{ MAX}$			40	μA		
$V_{OL}$	Low-level output voltage	$V_{CC} = \text{MIN}$	$I_{OL} = 16 \text{ mA}$	Com		0.45	V		
				Mil		0.5			
$V_{OH}$	High-level output voltage*	$V_{CC} = \text{MIN}$	Com $I_{OH} = -3.2 \text{ mA}$		2.4		V		
			Mil $I_{OH} = -2 \text{ mA}$						
$I_{OZL}$	Off-state output current*	$V_{CC} = \text{MAX}$	$V_O = 0.4 \text{ V}$			-40	μA		
$I_{OZH}$			$V_O = 2.4 \text{ V}$			40			
$I_{CEX}$	Open collector output current	$V_{CC} = \text{MAX}$	$V_O = 2.4 \text{ V}$			40	μA		
			$V_O = 5.5 \text{ V}$			100			
$I_{OS}$	Output short-circuit current**	$V_{CC} = 5 \text{ V}$	$V_O = 0 \text{ V}$			-20	-90	mA	
$I_{CC}$	Supply current	$V_{CC} = \text{MAX}$ . All inputs grounded. All outputs open.					95	140	mA

**Switching Characteristics Over Operating Conditions (See standard test load)**

OPERATING CONDITIONS	DEVICE TYPE	$t_{AA}$ (ns) ADDRESS ACCESS TIME		$t_{EA}$ AND $t_{ER}$ (ns) ENABLE ACCESS TIME RECOVERY TIME		UNIT
		TYP†	MAX	TYP†	MAX	
		COMMERCIAL	63S441A	24	35	
	63S440, 63S441	24	45	16	25	
MILITARY	53S441A	24	50	16	30	
	53S440, 53S441	24	55	16	30	

· Three-state only.

\*\* Not more than one output should be shorted at a time and duration of the short-circuit should not exceed one second.

† Typical at 5.0 V  $V_{CC}$  and 25°C  $T_A$ .