

## 2 Watt DC/DC Converters for LAN Transceiver Chips

### Key Features

- Meets FCC Section 15, Sub Part J, A and B
- Continuous short circuit protection with foldback on 2E models
- No derating to 71° C
- Wide input range



The LAN series of DC/DC converters is designed to provide power and isolation for Local Area Network (LAN) transceiver chips. The LAN series covers both the Cheapernet and Ethernet LAN (IEEE 802.3 - 10 base 5 and 10 base 2 Standards) approach. The use of a compact and inexpensive DC/DC converter as a power source for these transceiver chips allows conversion of the normal bus power to the isolated power required. The series operates from inputs of 5 and 12 VDC for Cheapernet with input/output isolation of 500 VDC. Ethernet converters offer a wide input range of 10.20 to 15.75 VDC with 2500 VDC isolation.

### General Electrical Specifications

(Specifications at Nominal Input and 25 C, nominal input voltage and rated output current unless otherwise noted.)

#### 2QP & 2SP Series

Parameter	Limits	Conditions
<b>Input Voltage Range</b>		
5V Devices	4.75 - 5.25 VDC	
12 V Devices	11.4 - 12.6 VDC	
<b>Input Filter</b>	Filter Capacitor	All Device Types
<b>Input/Output Isolation Voltage Resistance</b>	500 VDC (Min) 10 <sup>3</sup> megohms (Min)	
<b>Output Voltage Accuracy</b>	± 5%	Nom. Line at Full Load
<b>2QP &amp; 2SP Device Types</b>	See Graph*	
<b>Load Regulation</b>	See Graph*	
<b>Output Noise/Ripple</b>	100mV P-P (Max)	20Hz-20MHz Bandwidth
<b>Minimum Load Required</b>	10% of Full Load	All Units
<b>Line Regulation</b>	See Graph*	
<b>Short Circuit Protection</b>	Momentary	All Units
<b>Operating Temperature</b>	-25°C to +71°C	
<b>Derating</b>	None	To 71°C
<b>Storage Temperature</b>	-55°C to +125°C	
<b>FCC Sec 15, Sub Part J</b>	Yes	Class B Radiated, Class A Conducted

**General Electrical Specifications**

(Specifications at Nominal Input and 25 C, nominal input voltage and rated output current unless otherwise noted.)

**2E12R9 Series**

Parameter	Limits	Conditions
Input Voltage Range	10.2 - 15.75VDC	All Devices
Input Filter	Filter Capacitor	All Device Types
Input/Output Isolation Voltage Resistance	2500 VDC (Min) 10 <sup>3</sup> Megohms (Min)	All Device Types
Output Voltage Accuracy	± 5%	Nom. Line at Full Load
Load Regulation	50mV	Nom. Line, NL to FL
Line Regulation	300mV	Full Input Range, FL
Output Noise/Ripple	100mV, P-P (Max)	20Hz-20MHz Bandwidth
Short Circuit Protection Duration	Current Foldback Continuous	All Units
Switching Frequency	30 KHz	Typical
Operating Temperature	-25 °C to +71 °C	
Derating	None	To 71 °C
Storage Temperature	-55 °C to +125 °C	
External Heatsink Case	Recommended For Still Air Environments UL94V-0	
Encapsulant	UL94H-B	
Heat Dissipation	45 °C Case Rise	
FCC Sec 15, Sub Part J	Yes	High Line, Full Load Class B Radiated, Class A Conducted

**Selection Guide**

Device Type	Input Voltage Range VDC	Typical Input Current (A) @ Max Load	Output Voltage VDC	Max Output Current (mA)	Package/ Pinout
2QP5U9	4.75 - 5.25	.600	-9	250	QA
2SP5U9	4.75 - 5.25	.600	-9	250	SA
2QP12U9	11.40 - 12.60	.250	-9	250	QA
2E12R9	10.20 - 15.75	.350	-9	250	2E
2SP12U9	11.40 - 12.60	.250	-9	250	SA

**Reliability Power Locations**

HEADQUARTERS & CUSTOMER SERVICE	SALES
Reliability Power, Incorporated 33 Musick Irvine, CA 92618 USA Tel: (949) 305-6700 Fax: (949) 305-6701  <a href="http://www.reliabilitypower.com">www.reliabilitypower.com</a>	Reliability Power, Incorporated Attention: SALES  Tel: (805) 449-1667 Fax: (805) 557-4530  <a href="mailto:sales@reliabilitypower.com">sales@reliabilitypower.com</a>

**Mechanical Specification (dimensions in inches)**

**QPAC**

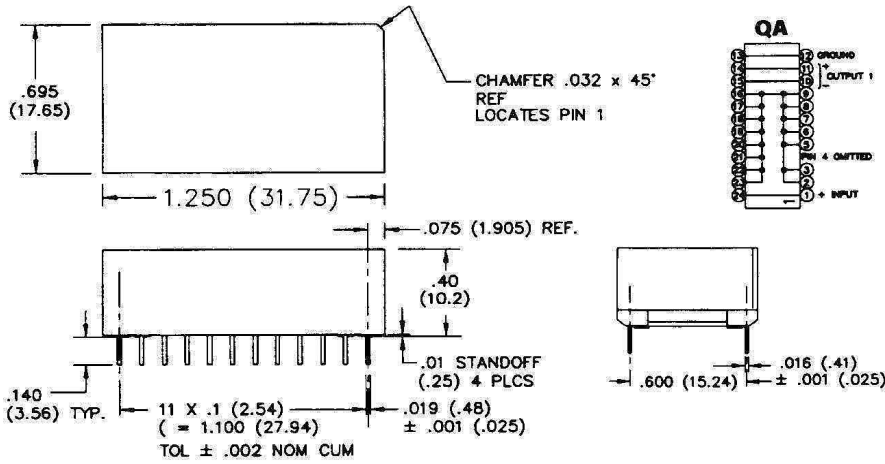

**NOTES (ALL DEVICES & PACKAGES):**

1. All dimensions in parentheses are metric.
2. Tolerances unless otherwise specified: .xx ± .03 (76) .xxx = ± .015 (38)

**MATERIALS:** Base and cover: Black Stanyl 4/6 nylon TE250F6 UL 94V-0 rated. Post style contact: half hard brass.

**PLATING:** Post style contact: 100µ" min 60/40 bright tin/lead per Mil-T-10727 over 50µ" min nickel per QQ-N-290.

Pin 4 is missing.

**SA**

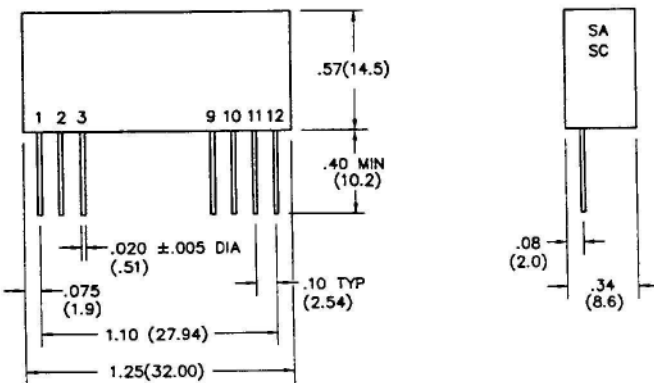

PIN	PIN CONNECTIONS
1	+INPUT
2	NC
3	NC
9	NC
10	-OUTPUT
11	+OUTPUT
12	-INPUT

**2E**

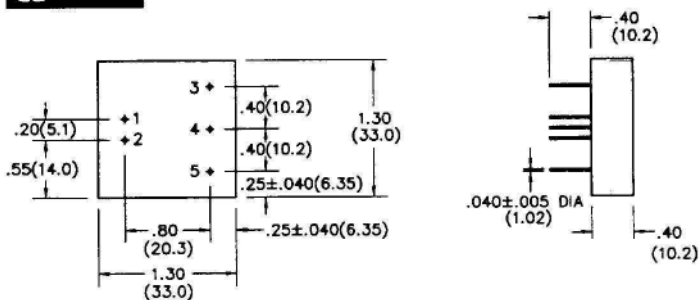

SINGLE 9V OUTPUT	
PIN	PIN CONNECTIONS
1	+INPUT
2	-INPUT
3	NO CONNECTION
4	OUTPUT COMMON
5	-OUTPUT