

Quad High-Current Power Driver

Features

- Wide Voltage Range
- High Current Drive
- Fast Rise and Fall Times
- Low Power Consumption
- Single Power Supply
- Low Output Impedance
- TTL/CMOS Inputs
- ESD Protection

Applications

- Motor Drives
- Power Supplies
- dc/dc Converters

End Products

- Computers
- Printers
- Avionics
- Industrial Controllers
- Robotics
- Central Office Equipment

Description

The D469A is a quad monolithic high-current and high-speed driver designed to interface logic level signals to power MOSFETs, at voltages up to 15 V, in motor

controls and other power control applications. This 4-channel power driver can source or sink up to 1.5 A.

Pin Configuration, Functional Block Diagram and Truth Table

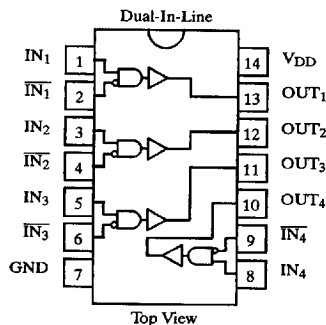

Truth Table

IN _x	IN _x [̄]	OUT _x
0	0	Low
0	1	Low
1	0	High
1	1	Low

Ordering Information

Temp Range	Package	Part Number
-40 to 85°C	14-Pin Plastic DIP	D469ADJ
		D469AAP
-55 to 125°C	14-Pin Sidebraze	D469AAP/883
		5962-9098301MCA

Absolute Maximum Ratings

Ambient Temperature Under Bias	-55 to 125°C
Voltage on Any Pin with Respect to Ground	-0.3 to V _{DD} +0.3 V
Supply Voltage, V _{DD}	-0.3 to 18 V
Peak Output Current	±1.5 A
DC Continuous Current (Any Output)	100 mA
AC Time Average Current	100 mA
Storage Temperature	-65 to 150°C
Operating Temperature (A Suffix)	-55 to 125°C
(D Suffix)	-40 to 85°C
Junction Temperature	150°C

Power Dissipation (Package)^a

14-Pin Plastic DIP^b 1000 mW

14-Pin Sidebraze^c 750 mW

Thermal Impedance (Θ_{JA})

14-Pin Plastic DIP 100°C/W (No Airflow)

14-Pin Sidebraze 167°C/W (No Airflow)

Notes

- Device mounted with all leads soldered or welded to PC board.
- Derate 10 mW/°C above 50°C.
- Derate 6 mW/°C above 25°C.

Specifications

Parameter	Symbol	Test Conditions Unless Otherwise Specified $V_{DD} = 15\text{ V}$ $T_A = \text{Operating Temperature Range}$	Limit			Unit
			Min ^a	Typ ^b	Max ^a	
Input						
Input Voltage High	V_{INH}		2.4			V
Input Voltage Low	V_{INL}				0.8	
Input Current, Input Voltage High	I_{INH}	$V_{IN} = V_{DD}$		0.001	10	μA
Input Current, Input Voltage Low	I_{INL}	$V_{IN} = 0\text{ V}$	-10	-0.001		
Output						
Output Voltage High	V_{OUTH}	$I_{OUT} = -100\text{ mA}$, One Output at a Time	13	14.44		V
		$I_{OUT} = -10\text{ mA}$	14.8	14.95		
Output Voltage Low	V_{OUTL}	$I_{OUT} = 100\text{ mA}$, One Output at a Time		0.33	1	V
		$I_{OUT} = 10\text{ mA}$		0.033	0.1	
Output Source Current	I_{OS+}			1.5		A
Output Sink Current	I_{OS1}			-1.5		
Output Resistance	R_{OUT}	$I_{OUT} = 10\text{ mA}$		3.5		Ω
		$I_{OUT} = -10\text{ mA}$		5.5		
Dynamic						
Propagation Delay	t_{px}	$C_L = 1000\text{ pF}$ (See Figure 1)		30	80	ns
Rise Time	t_r			10		
Fall Time	t_f			10		
Input Capacitance	C_{in}			5		pF
Supply						
Supply Current	I_{DD}	$I_{NX} = \overline{I_{NX}} = 0\text{ V}$, $V_{DD} = 15.75\text{ V}$		1.4	20	mA
		$I_{NX} = \overline{I_{NX}} = 3\text{ V}$, $V_{DD} = 15.75\text{ V}$		1.4	30	
		$f = 100\text{ kHz}$, $V_{DD} = 15.75\text{ V}$, $C_L = 1000\text{ pF}$ One Output at a Time		7	20	

Notes

- a. The algebraic convention whereby the most negative value is a minimum and the most positive a maximum.
 b. Typical values are for DESIGN AID ONLY, not guaranteed nor subject to production testing.

AC Test Conditions

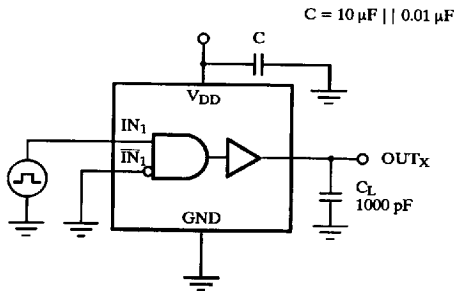
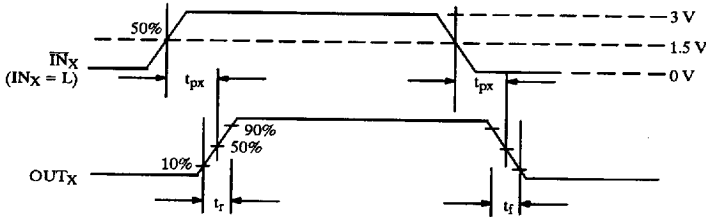
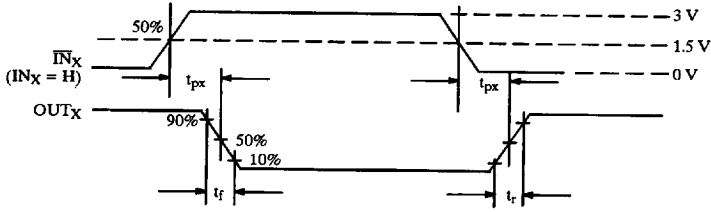

Note: Test repeated for inverting input.

Figure 1. Switching Time Test Circuit

4
Motor Control
MOSFET Drivers

D469A

Typical Characteristics

