

## 1. General description

---

The ISP1581 is a cost-optimized and feature-optimized Universal Serial Bus (USB) interface device, which fully complies with the *Universal Serial Bus Specification Rev. 2.0*. It provides high-speed USB communication capacity to systems based on a microcontroller or microprocessor. The ISP1581 communicates with the system's microcontroller/processor through a high-speed general-purpose parallel interface.

The ISP1581 supports automatic detection of USB 2.0 system operation. The USB 1.1 fall-back mode allows the device to remain operational under full-speed conditions. It is designed as a generic USB interface device so that it can fit into all existing device classes, such as: Imaging Class, Mass Storage Devices, Communication Devices, Printing Devices and Human Interface Devices.

The internal generic DMA block allows easy integration into data streaming applications. In addition, the various configurations of the DMA block are tailored for mass storage applications.

The modular approach to implementing a USB interface device allows the designer to select the optimum system microcontroller from the wide variety available. The ability to re-use existing architecture and firmware investments shortens the development time, eliminates risk and reduces costs. The result is fast and efficient development of the most cost-effective USB peripheral solution.

The ISP1581 is ideally suited for many types of peripherals, such as: printers; scanners; magneto-optical (MO), compact disc (CD), digital video disc (DVD) and Zip®/Jaz® drives; digital still cameras; USB-to-Ethernet links; cable and DSL modems. The low power consumption during 'suspend' mode allows easy design of equipment that is compliant to the ACPI™, OnNow™ and USB power management requirements.

The ISP1581 also incorporates features such as SoftConnect™, a reduced frequency crystal oscillator and integrated termination resistors. These features allow significant cost savings in system design and easy implementation of advanced USB functionality into PC peripherals.

## 2. Features

- Complies fully with Universal Serial Bus Specification Rev. 2.0
- Complies with most Device Class specifications
- High performance USB interface device with integrated Serial Interface Engine (SIE), FIFO memory, data transceiver and 3.3 V voltage regulators
- Supports automatic USB 2.0 mode detection and USB 1.1 fall-back mode
- High speed DMA interface
- Fully autonomous and multi-configuration DMA operation
- Up to 14 programmable USB endpoints with 2 fixed control IN/OUT endpoints
- Integrated physical 8 kbyte of multi-configuration FIFO memory
- Endpoints with double buffering to increase throughput and ease real-time data transfer
- Bus independent interface with most microcontroller/microprocessors (16 Mbytes/s or 16 Mwords/s)
- Bus-powered capability with low power consumption and low 'suspend' current
- 12 MHz crystal oscillator with integrated PLL for low EMI
- Software controlled connection to the USB bus (SoftConnect™)
- Complies with the ACPI™, OnNow™ and USB power management requirements
- Internal power-on and low-voltage reset circuit, also supporting a software reset
- Operation over the extended USB bus voltage range (4.0 to 5.5 V) with 5 V tolerant I/O pads
- Operating temperature range –40 to +85 °C
- 12 kV in-circuit ESD protection on human accessible pins such as D+ and D–
- Full-scan design with high fault coverage (>99%)
- Available in LQFP64 package.

## 3. Applications

- Personal digital assistant (PDA)
- Mass storage device, e.g., Zip®, Jaz®, MO, CD, DVD drive
- Digital camera
- Communication device, e.g. router, modem
- Printer
- Scanner.

## 4. Ordering information

Table 1: Ordering information

Type number	Package		
	Name	Description	Version
ISP1581BD	LQFP64	Plastic low profile quad flat package; 64 leads; body 10 x 10 x 1.4 mm	SOT314-2

5. Block diagram

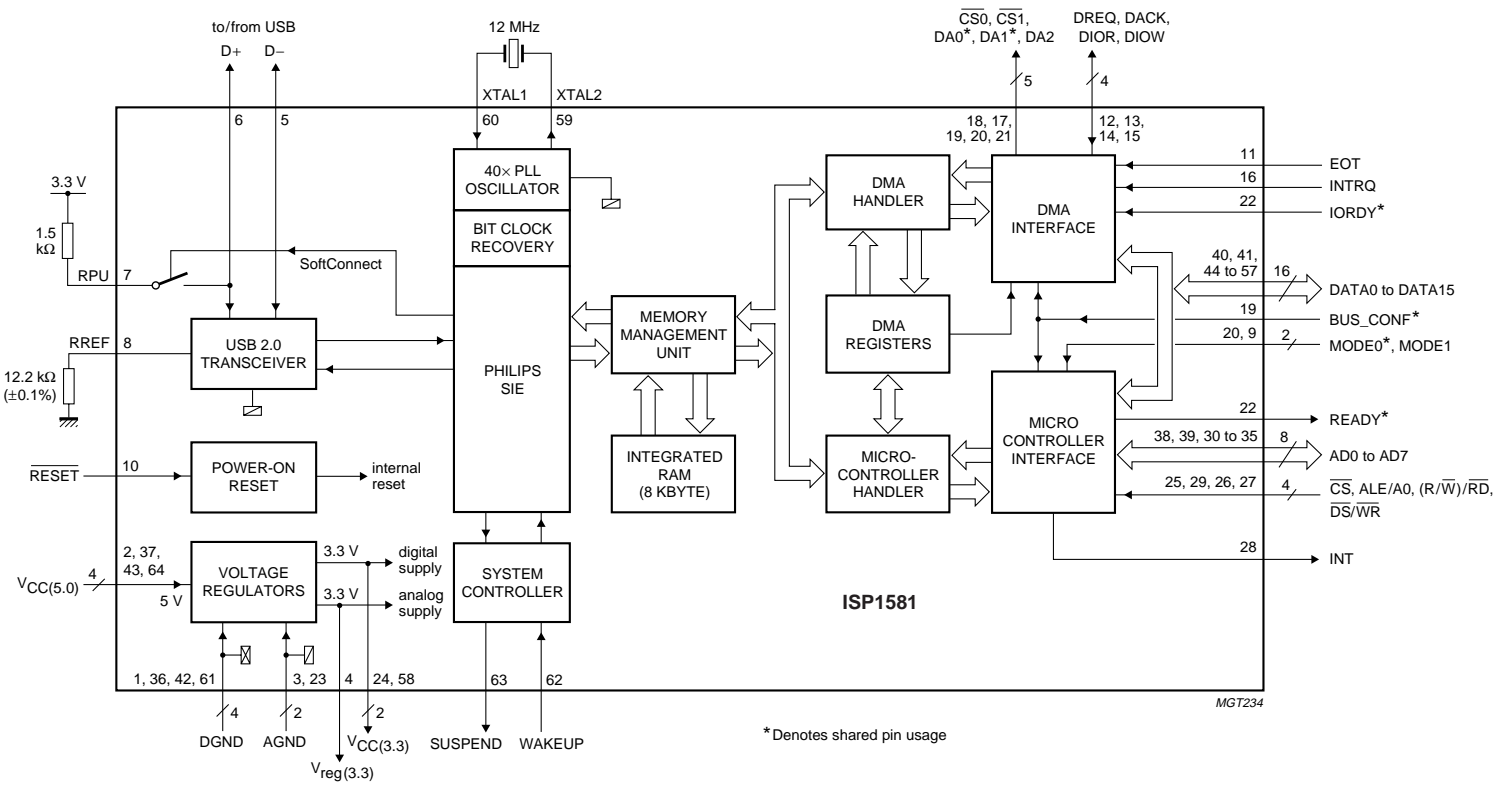

The direction of pins DREQ, DACK, DIOR and DIOW is determined by bit MASTER (DMA Hardware register) and bit ATA\_MODE (DMA Configuration register).

Fig 1. Block diagram.

## 6. Pinning information

### 6.1 Pinning

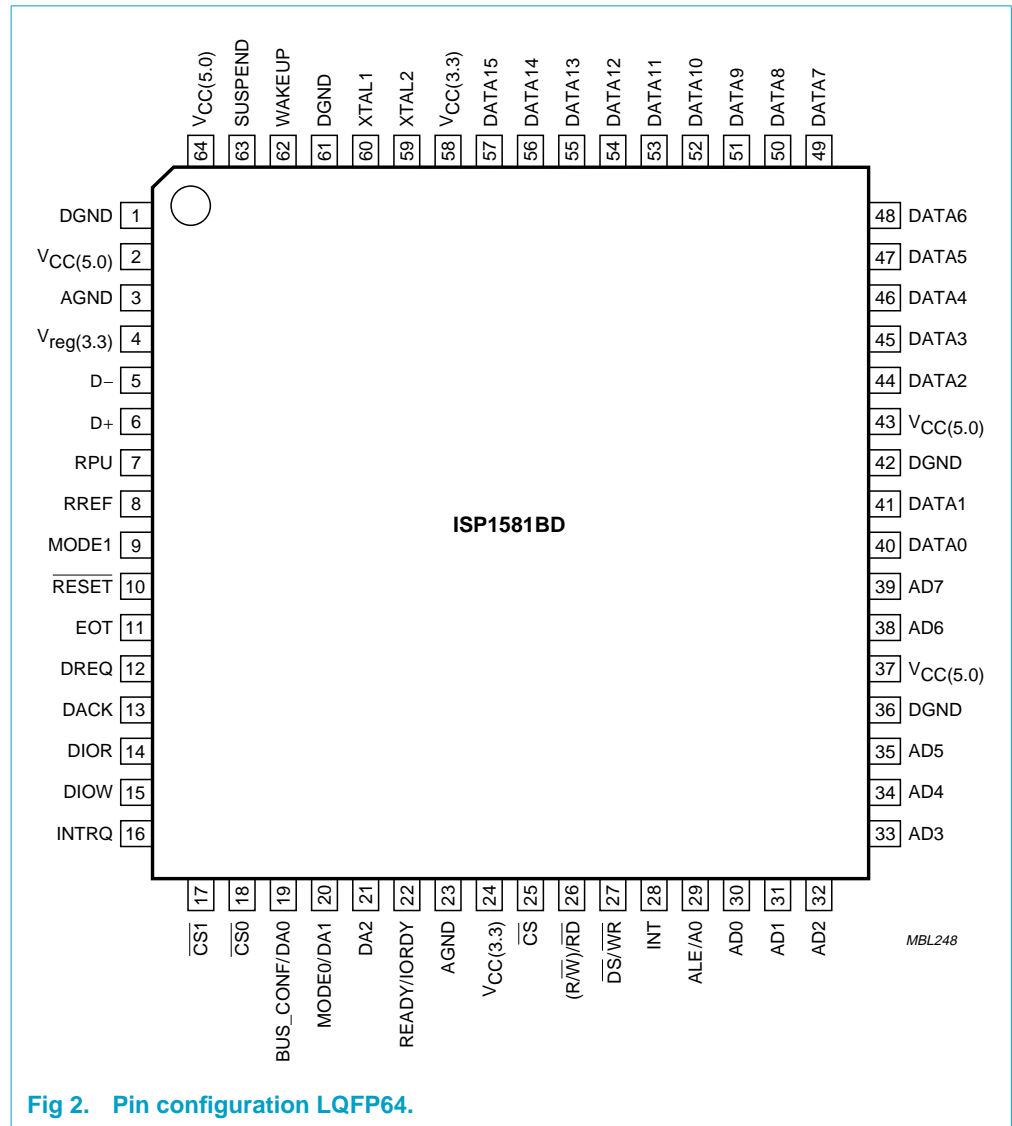

## 6.2 Pin description

Table 2: Pin description for LQFP64

Symbol <sup>[1]</sup>	Pin	Type <sup>[2]</sup>	Description
DGND	1	-	digital ground
V <sub>CC(5.0)</sub>	2	-	supply voltage (3.3 or 5.0 V)
AGND	3	-	analog ground
V <sub>reg(3.3)</sub>	5	-	regulated supply voltage (3.3 V ± 10%) from internal regulator; supplies internal analog circuits; used to connect decoupling capacitor and 1.5 kΩ pull-up resistor on D+ line <b>Remark:</b> Cannot be used to supply external devices.
D-	5	AI/O	USB D- connection (analog)
D+	6	AI/O	USB D+ connection (analog)
RPU	7	AI	connection for external pull-up resistor for USB D+ line; must be connected to V <sub>reg(3.3)</sub> via a 1.5 kΩ resistor
RREF	8	AI	connection for external bias resistor; must be connected to ground via a 12.2 kΩ (± 0.1%) resistor
MODE1	9	I	selects function of pin ALE/A0 (in Split Bus mode only): <b>0</b> — ALE function (address latch enable) <b>1</b> — A0 function (address/data indicator). <b>Remark:</b> Connect to V <sub>CC(5.0)</sub> in Generic Processor mode.
RESET	10	I	reset input (Schmitt trigger); a LOW level produces an asynchronous reset; connect to V <sub>CC</sub> for power-on reset (internal POR circuit)
EOT	11	I	End Of Transfer input (programmable polarity, see Table 37); used in DMA slave mode only
DREQ	12	I/O	DMA request (programmable polarity); direction depends on the bit MASTER in the DMA Hardware register (DMA master: input, DMA slave: output); see Table 37
DACK	13	I/O	DMA acknowledge (programmable polarity); direction of depends on bit MASTER in the DMA Hardware register (DMA slave: input, DMA master: output); see Table 37
DIOR	14	I/O	DMA read strobe (programmable polarity); direction depends on bit MASTER in the DMA Hardware register (DMA slave: input, DMA master: output); see Table 37
DIOW	15	I/O	DMA write strobe (programmable polarity); direction depends on bit MASTER in the DMA Hardware register (DMA slave: input, DMA master: output); see Table 37
INTRQ	16	I	interrupt request input from ATA/ATAPI peripheral
CS1	17	O	chip select output for ATAPI device
CS0	18	O	chip select output for ATAPI device
BUS_CONF/ DA0	19	I/O	<b>during power-up:</b> input to select the bus configuration <b>0</b> — Split Bus mode; multiplexed 8-bit address/data bus on AD[7:0], separate 8/16-bit DMA data bus on DATA[15:0] <b>1</b> — Generic Processor mode; separate 8-bit address on AD[7:0], 16-bit DMA data bus on DATA[15:0]. <b>normal operation:</b> address output to select the task file register of an ATAPI device

Table 2: Pin description for LQFP64 ...continued

Symbol <sup>[1]</sup>	Pin	Type <sup>[2]</sup>	Description
MODE0/DA1	20	I/O	<p><b>during power-up:</b> input to select the read/write strobe functionality in generic processor mode</p> <p><b>0</b> — Motorola style: pin 26 is <math>\overline{R\overline{W}}</math> and pin 27 is <math>\overline{DS}</math></p> <p><b>1</b> — 8051 style: pin 26 is <math>\overline{RD}</math> and pin 27 is <math>\overline{WR}</math></p> <p><b>normal operation:</b> address output to select the task file register of an ATAPI device</p>
DA2	21	O	address output to select the task file register of an ATAPI device
READY/ IORDY	22	I/O	<p><b>Generic processor mode:</b> ready signal (READY; output) A LOW level signals that ISP1581 is processing a previous command or data and is not ready for the next command or data transfer; a HIGH level signals that ISP1581 is ready for the next microprocessor read or write.</p> <p><b>Split Bus mode:</b> DMA ready signal (IORDY; input); used for accessing ATAPI peripherals (PIO and UDMA modes only).</p>
AGND	23	-	analog ground
$V_{CC(3.3)}$	24	-	supply voltage (3.3 V $\pm$ 10%); supplies internal digital circuits
$\overline{CS}$	25	I	chip select input
$(\overline{R\overline{W}})/\overline{RD}$	26	I	input; function is determined by input MODE0 at power-up: <b>MODE0 = 0</b> — pin functions as $\overline{R\overline{W}}$ (Motorola style) <b>MODE0 = 1</b> — pin functions as $\overline{RD}$ (8051 style).
$\overline{DS}/\overline{WR}$	27	I	input; function is determined by input MODE0 at power-up: <b>MODE0 = 0</b> — pin functions as $\overline{DS}$ (Motorola style) <b>MODE0 = 1</b> — pin functions as $\overline{WR}$ (8051 style).
INT	28	O	interrupt output; programmable polarity (active HIGH or LOW) and signaling (edge or level triggered)
ALE/A0	29	I	input; function determined by input MODE1 during power-up: <b>MODE1 = 0</b> — address latch enable; a falling edge latches the address on the multiplexed address/data bus (AD[7:0]) <b>MODE1 = 1</b> — address/data selection on AD[7:0]; a logic 1 indicates that an address will be written at the next $\overline{WR}$ pulse; a logic 0 indicates that data will be written at the next $\overline{WR}$ pulse; used in Split Bus mode only.
AD0	30	I/O	bit 0 of multiplexed address/data
AD1	31	I/O	bit 1 of multiplexed address/data
AD2	32	I/O	bit 2 of multiplexed address/data
AD3	33	I/O	bit 3 of multiplexed address/data
AD4	34	I/O	bit 4 of multiplexed address/data
AD5	35	I/O	bit 5 of multiplexed address/data
DGND	36	-	digital ground
$V_{CC(5.0)}$	37	-	supply voltage (3.3 or 5.0 V)
AD6	38	I/O	bit 6 of multiplexed address/data

Table 2: Pin description for LQFP64 ...continued

Symbol <sup>[1]</sup>	Pin	Type <sup>[2]</sup>	Description
AD7	39	I/O	bit 7 of multiplexed address/data
DATA0	40	I/O	bit 0 of bidirectional data
DATA1	41	I/O	bit 1 of bidirectional data
DGND	42	-	digital ground
V <sub>CC(5.0)</sub>	43	-	supply voltage (3.3 or 5.0 V)
DATA2	44	I/O	bit 2 of bidirectional data
DATA3	45	I/O	bit 3 of bidirectional data
DATA4	46	I/O	bit 4 of bidirectional data
DATA5	47	I/O	bit 5 of bidirectional data
DATA6	48	I/O	bit 6 of bidirectional data
DATA7	49	I/O	bit 7 of bidirectional data
DATA8	50	I/O	bit 8 of bidirectional data
DATA9	51	I/O	bit 9 of bidirectional data
DATA10	52	I/O	bit 10 of bidirectional data
DATA11	53	I/O	bit 11 of bidirectional data
DATA12	54	I/O	bit 12 of bidirectional data
DATA13	55	I/O	bit 13 of bidirectional data
DATA14	56	I/O	bit 14 of bidirectional data
DATA15	57	I/O	bit 15 of bidirectional data
V <sub>CC(3.3)</sub>	58	-	supply voltage (3.3 V ± 10%); supplies internal digital circuits
XTAL2	59	O	crystal oscillator output (12 MHz); connect a fundamental parallel-resonant crystal; leave this pin open when using an external clock source on pin XTAL1
XTAL1	60	I	crystal oscillator input (12 MHz); connect a fundamental parallel-resonant crystal or an external clock source (leaving pin XTAL2 unconnected)
DGND	61	-	digital ground
WAKEUP	62	I	wake-up input (edge triggered); a LOW-to-HIGH transition generates a remote wake-up from 'suspend' state
SUSPEND	63	O	'suspend' state indicator output (4 mA); used as a power switch control output (active LOW) for powered-off application or as a resume signal to the CPU (active HIGH) for powered-on application
V <sub>CC(5.0)</sub>	64	-	supply voltage (3.3 or 5.0 V)

[1] Symbol names with an overscore (e.g.  $\overline{\text{NAME}}$ ) represent active LOW signals.

[2] All outputs and I/O pins can source 4 mA of current.

## 7. Functional description

The ISP1581 is a high-speed USB device controller. It implements the USB 2.0/1.1 physical layer, the packet protocol layer and maintains up to 16 USB endpoints concurrently (2 control, 14 configurable). *USB Chapter 9* protocol handling is executed by means of external firmware.

The ISP1581 has a fast general-purpose interface for communication with most types of microcontrollers/processors. This Microcontroller Interface is configured by pins BUS\_CONF, MODE1 and MODE0 to accommodate most interface types. Two bus configurations are available, selected via input BUS\_CONF during power-up:

- **Generic Processor mode (BUS\_CONF = 1):**
  - AD[7:0]: 8-bit address bus (selects target register)
  - DATA[15:0]: 16-bit data bus (shared by processor and DMA)
  - Control signals:  $R/\overline{W}$  and  $\overline{DS}$  or  $\overline{RD}$  and  $\overline{WR}$  (selected via pin MODE0)
  - DMA interface (generic slave mode only): uses lines DATA[15:0] as data bus, DIOR and DIOW as dedicated read and write strobes.
- **Split Bus mode (BUS\_CONF = 0):**
  - AD[7:0]: 8-bit local microprocessor bus (multiplexed address/data)
  - DATA[15:0]: 16-bit DMA data bus
  - Control signals:  $\overline{CS}$ , ALE or A0 (selected via pin MODE1),  $R/\overline{W}$  and  $\overline{DS}$  or  $\overline{RD}$  and  $\overline{WR}$  (selected via pin MODE0)
  - DMA interface (master or slave mode): uses DIOR and DIOW as dedicated read and write strobes.

For high-bandwidth data transfer, the integrated DMA handler can be invoked to transfer data to/from external memory or devices. The DMA Interface can be configured by writing to the proper DMA registers (see [Section 9.4](#)).

The ISP1581 supports high-speed USB 2.0 and full-speed USB 1.1 signaling. Detection of the USB signaling speed is done automatically.

ISP1581 has 8 kbytes of internal FIFO memory, which is shared among the enabled USB endpoints.

There are 14 configurable data endpoints and 2 control endpoints. Any of the 14 data endpoints can be separately enabled or disabled. The endpoint type (interrupt, isochronous or bulk) and packet size of these endpoints can be individually configured depending on the requirements of the application. Optional double buffering increases the data throughput of the data endpoints.

The ISP1581 requires a single supply of 3.0 V or 5.0 V, depending on the I/O voltage. It has 5.0 V tolerant I/O pads and has an internal 3.3 V regulator for powering the analog transceiver. It supports bus-powered operation with a 'suspend' current below 500  $\mu$ A.

The ISP1581 operates on a 12 MHz crystal oscillator. An integrated 40 $\times$  PLL clock multiplier generates the internal sampling clock of 480 MHz.

## 7.1 USB 2.0 transceiver

The analog transceiver interfaces directly to the USB cable via integrated termination resistors. The high-speed transceiver requires an external resistor ( $12.2 \text{ k}\Omega \pm 0.1\%$ ) between pin RREF and ground to ensure an accurate current mirror. A full-speed transceiver is integrated as well. This makes the ISP1581 compliant with USB 2.0



and USB 1.1, supporting both the high-speed and full-speed physical layer. After automatic speed detection, the Philips Serial Interface Engine sets the transceiver to use either high-speed or full-speed signaling.

## 7.2 Philips Serial Interface Engine (SIE)

The Philips SIE implements the full USB protocol layer. It is completely hardwired for speed and needs no firmware intervention. The functions of this block include: synchronization pattern recognition, parallel/serial conversion, bit (de-)stuffing, CRC checking/generation, Packet Identifier (PID) verification/generation, address recognition, handshake evaluation/generation.

## 7.3 Voltage regulators

Two 5 V to 3.3 V voltage regulators are integrated on-chip to separately supply the analog transceiver and the internal logic. The analog supply voltage is available at pin  $V_{\text{reg}(3.3)}$  to supply an external 1.5 k $\Omega$  pull-up resistor on the D+ line.

**Remark:** Pin  $V_{\text{reg}(3.3)}$  cannot be used to supply external devices.

## 7.4 Memory Management Unit (MMU) and integrated RAM

The MMU and the integrated RAM provide the conversion between the USB speed (full speed: 12 Mbit/s, high speed: 480 Mbit/s) and the Microcontroller Handler or the DMA Handler. The data from the USB Bus is stored in the integrated RAM, which is cleared only when the microcontroller clears the endpoint buffer or when the DMA Handler has read/written all data from/to the endpoint buffer. A total of 8 kbytes RAM is available for buffering.

## 7.5 SoftConnect

The connection to the USB is established by pulling the D+ line (for high-speed devices) HIGH through a 1.5 k $\Omega$  pull-up resistor. In the ISP1581 an external 1.5 k $\Omega$  pull-up resistor must be connected between pins RPU and  $V_{\text{reg}(3.3)}$ . The RPU pin connects the pull-up resistor to the D+ line, when bit SOFTCT in the Mode register is set (see [Table 7](#)). After a hardware reset the pull-up resistor is disconnected by default (SOFTCT = 0). Bit SOFTCT remains unchanged by a USB bus reset.

## 7.6 Bit clock recovery

The bit clock recovery circuit recovers the clock from the incoming USB data stream using 4 $\times$  over-sampling principle. It is able to track the jitter and the frequency drift as specified by the USB specification.

## 7.7 Multiplying PLL oscillator

A 12 MHz to 480 MHz clock multiplier Phase-Locked Loop (PLL) is integrated on-chip. This allows the use of a low-cost 12 MHz crystal, which also minimizes EMI. No external components are needed for the operation of the PLL.

## 7.8 Microcontroller Interface and Microcontroller Handler

The Microcontroller Interface allows direct interfacing to most microcontrollers. The interface is configured at power-up via inputs BUS\_CONF, MODE1 and MODE0.

When BUS\_CONF is set to logic 1, the Microcontroller Interface switches to the **Generic Processor mode** in which AD[7:0] is the 8-bit address bus and DATA[15:0] is the separate 16-bit data bus. If BUS\_CONF is made logic 0, the interface is in the **Split Bus mode**, where AD[7:0] is the local microprocessor bus (multiplexed address/data) and DATA[15:0] is used as the DMA bus.

If pin MODE0 is set to logic 1, pins  $\overline{RD}$  and  $\overline{WR}$  are the read and write strobes (8051 style). If pin MODE0 is logic 0, pins  $R/\overline{W}$  and  $\overline{DS}$  pins represent the direction and data strobe (Motorola style).

When pin MODE1 is made logic 0, ALE is used to latch the multiplexed address on pins AD[7:0]. If pin MODE1 is set to logic 1, A0 is used to indicate address or data. Pin MODE1 is only used in Split Bus mode: in Generic Processor mode it must be tied to  $V_{CC(5.0)}$  (logic 1).

The Microcontroller Handler allows the external microcontroller to access the register set in the Philips SIE as well as the DMA Handler. The initialization of the DMA configuration is done via the Microcontroller Handler.

## 7.9 DMA Interface and DMA Handler

The DMA block can be subdivided into two blocks: the DMA Handler and the DMA Interface.

The firmware writes to the DMA Command register to start a DMA transfer (see [Table 30](#)). The command opcode determines whether a generic DMA, PIO, MDMA or UDMA transfer will start. The Handler interfaces to the same FIFO (internal RAM) as used by the USB core. Upon receiving the DMA Command, the DMA Handler directs the data from the internal RAM to the external DMA device and vice versa.

The DMA Interface configures the timings and how the DMA data is accessed. Data can be transferred either using DIOR and DIOW strobes or by the DACK and DREQ handshakes. The different DMA configurations are set up by writing to the DMA Configuration register (see [Table 35](#)).

For an IDE-based storage interface, the applicable DMA modes are PIO (Parallel I/O), MDMA (Multiword DMA; ATA), and UDMA (Ultra DMA; ATA).

For a generic DMA interface, the DMA modes that can be used are Generic DMA (Slave) and MDMA (Master).

## 7.10 System Controller

The System Controller implements the USB power-down capabilities of the ISP1581. Two modes are supported during 'suspend' state: **powered-on** and **powered-off**. These modes are selected via bit PWROFF in the Mode register (see [Table 7](#)). Registers are protected against data corruption during wake-up following a 'resume'.

## 8. Modes of operation

The ISP1581 has two bus configuration modes, selected via pin BUS\_CONF/DA0 at power-up:

- **Split Bus mode (BUS\_CONF = 0):** 8-bit multiplexed address/data bus and separate 8-bit/16-bit DMA bus
- **Generic Processor mode (BUS\_CONF = 1):** separate 8-bit address and 16-bit data bus

Details of the bus configurations for each mode are given in [Table 3](#). Typical interface circuits for each mode are given in [Section 13 “Application information”](#).

**Table 3: Bus configuration modes**

BUS_CONF	PIO width	DMA width		Description
		DMAWD = 0	DMAWD = 1	
0	AD[7:0]	D[7:0]	D[15:0]	<b>Split Bus mode:</b> multiplexed address/data on pins AD[7:0]; separate 8/16-bit DMA bus on pins DATA[15:0]
1	A[7:0] D[15:0]	D[7:0]	D[15:0]	<b>Generic Processor mode:</b> separate 8-bit address on pins AD[7:0]; 16-bit data (PIO and DMA) on pins DATA[15:0]

## 9. Register descriptions

**Table 4: Register summary**

Name	Destination	Address (Hex)	Description	Size (bytes)
<b>Initialization registers</b>				
Address	device	00	USB device address + enable	1
Mode	device	0C	power-down options, global interrupt enable, SoftConnect	1
Interrupt Configuration	device	10	interrupt sources, trigger mode, output polarity	1
Interrupt Enable	device	14	interrupt source enabling	4
DMA Configuration	DMA controller	38	see <b>DMA registers</b>	2
DMA Hardware	DMA controller	3C	see <b>DMA registers</b>	1
<b>Data flow registers</b>				
Endpoint Index	endpoints	2C	endpoint selection, data flow direction	1
Control Function	endpoint	28	endpoint buffer management	1
Data Port	endpoint	20	data access to endpoint FIFO	2
Buffer Length	endpoint	1C	packet size counter	2
Endpoint MaxPacketSize	endpoint	04	maximum packet size	2
Endpoint Type	endpoint	08	selects endpoint type: control, isochronous, bulk or interrupt	2
Short Packet	endpoint	24	short packet received on OUT endpoint	2

Table 4: Register summary...continued

Name	Destination	Address (Hex)	Description	Size (bytes)
<b>DMA registers</b>				
DMA Command	DMA controller	30	controls all DMA transfers	1
DMA Transfer Counter	DMA controller	34	sets byte count for DMA Transfer	4
DMA Configuration	DMA controller	38 (byte 0)	sets GDMA configuration (counter enable, burst length, data strobing, bus width)	1
		39 (byte 1)	sets ATA configuration (IORDY enable, mode selection: ATA/UDMA/MDMA/PIO)	1
DMA Hardware	DMA controller	3C	endian type, master/slave selection, signal polarity for DACK, DREQ, DIOW, DIOR	1
1F0 Task File	ATAPI peripheral	40	single address word register: byte 0 (lower byte) is accessed first	2
1F1 Task File	ATAPI peripheral	48	IDE device access	1
1F2 Task File	ATAPI peripheral	49	IDE device access	1
1F3 Task File	ATAPI peripheral	4A	IDE device access	1
1F4 Task File	ATAPI peripheral	4B	IDE device access	1
1F5 Task File	ATAPI peripheral	4C	IDE device access	1
1F6 Task File	ATAPI peripheral	4D	IDE device access	1
1F7 Task File	ATAPI peripheral	44	IDE device access (write only; reading returns 00H)	1
3F6 Task File	ATAPI peripheral	4E	IDE device access	1
3F7 Task File	ATAPI peripheral	4F	IDE device access	1
DMA Interrupt Reason	DMA controller	50 (byte 0)	shows reason (source) for DMA interrupt	1
		51 (byte 1)		1
DMA Interrupt Enable	DMA controller	54 (byte 0)	enables DMA interrupt sources	1
		55 (byte 1)		1
DMA Endpoint	DMA controller	58	selects endpoint FIFO, data flow direction	1
DMA Strobe Timing	DMA controller	60	strobe duration in UDMA/MDMA mode	1
<b>General registers</b>				
Interrupt	device	18	shows interrupt sources	4
Chip ID	device	70	product ID code and hardware version	3
Frame Number	device	74	last successfully received Start Of Frame: lower byte (byte 0) is accessed first	2
Scratch	device	78	allows save/restore of firmware status during 'suspend'	2
Unlock Device	device	7C	re-enables register access after 'suspend'	2
Test Mode	PHY	84	direct setting of D+, D- states, loopback mode, internal transceiver test (PHY)	1

## 9.1 Register access

Register access depends on the bus width used:

- **8-bit bus:** multi-byte registers are accessed lower byte (LSB) first.
- **16-bit bus:** for single-byte registers the upper byte (MSB) must be ignored.

Endpoint specific registers are indexed via the Endpoint Index register. The target endpoint must be selected first, before accessing the following registers:

- Buffer Length
- Control Function
- Data Port
- Endpoint MaxPacketsize
- Endpoint Type
- Short Packet.

## 9.2 Initialization registers

### 9.2.1 Address register (address: 00H)

This register is used to set the USB assigned address and enable the USB device. [Table 5](#) shows the Address register bit allocation.

The DEVEN and DEVADDR bits will be cleared whenever a bus reset, a power-on reset or a soft reset occurs.

In response to the standard USB request SET\_ADDRESS, the firmware must write the (enabled) device address to the Address register, followed by sending an empty packet to the host. The **new** device address is activated when the host acknowledges the empty packet.

**Table 5: Address register: bit allocation**

Bit	7	6	5	4	3	2	1	0
Symbol	DEVEN	DEVADDR[6:0]						
Reset	0	00H						
Bus reset	0	00H						
Access	R/W	R/W						

**Table 6: Endpoint Configuration register: bit description**

Bit	Symbol	Description
7	DEVEN	A logic 1 enables the device.
6 to 0	DEVADDR[6:0]	This field specifies the USB device address.

### 9.2.2 Mode register (address: 0CH)

This register consists of 1 byte (bit allocation: see Table 7). In 16-bit bus mode the upper byte is ignored.

The Mode register controls the resume, suspend and wake-up behaviour, interrupt activity, soft reset, clock signals and SoftConnect operation. This register also controls the Power Off mode during 'suspend' state.

Table 7: Mode register: bit allocation

Bit	7	6	5	4	3	2	1	0
Symbol	CLKAON	SNDRSU	GOSUSP	SFRESET	GLINTENA	WKUPCS	PWROFF	SOFTCT
Reset	0	0	0	0	0	0	0	0
Bus reset	0	0	0	0	unchanged	0	unchanged	unchanged
Access	R/W	R/W	R/W	R/W	R/W	R/W	R/W	R/W

Table 8: Mode register: bit description

Bit	Symbol	Description
7	CLKAON	<b>Clock Always On:</b> A logic 1 indicates that the internal clocks are always running even during 'suspend' state. A logic 0 switches off the internal oscillator and PLL, when they are not needed. During 'suspend' state, this bit must be set to logic 0 to meet the suspend current requirements. The clock is stopped after a delay of approximately 2 ms, following the setting of bit GOSUSP.
6	SNDRSU	<b>Send Resume:</b> Writing a logic 1 followed by a logic 0 will generate an upstream 'resume' signal of 10 ms duration, after a 5 ms delay.
5	GOSUSP	<b>Go Suspend:</b> Writing a logic 1 followed by a logic 0 will activate 'suspend' mode.
4	SFRESET	<b>Soft Reset:</b> Writing a logic 1 followed by a logic 0 will enable a software-initiated reset to ISP1581. A soft reset is similar to a hardware-initiated reset (via the $\overline{\text{RESET}}$ pin).
3	GLINTENA	<b>Global Interrupt Enable:</b> A logic 1 enables all interrupts. Individual interrupts can be masked OFF by clearing the corresponding bits in the Interrupt Enable register. Bus reset value: unchanged.
2	WKUPCS	<b>Wake-up on Chip Select:</b> A logic 1 enables remote wake-up via a LOW level on input CS.
1	PWROFF	<b>Power Off mode:</b> A logic 1 enables powering-off during 'suspend' state. Output SUSPEND is configured as a power switch control signal for external devices (HIGH during 'suspend'). Bus reset value: unchanged.
0	SOFTCT	<b>SoftConnect:</b> A logic 1 enables the connection of the 1.5 k $\Omega$ pull-up resistor on pin RPU to the D+ line. Bus reset value: unchanged.

9.2.3 Interrupt Configuration register (address: 10H)

This 1-byte register determines the behaviour and polarity of the INT output. The bit allocation is shown in Table 9. When the USB SIE receives or generates a ACK, NAK or STALL, it will generate interrupts depending on three Debug mode bit fields:

- CDBGMOD[1:0]: interrupts for the Control endpoint 0
- DDBGMODIN[1:0]: interrupts for the DATA IN endpoints 1 to 7
- DDBGMODOUT[1:0]: interrupts for the DATA OUT endpoints 1 to 7.

The Debug mode settings for CDBGMOD, DDBGMODIN and DDBGMODOUT allow the user to individually configure when the ISP1581 will send an interrupt to the external microprocessor. Table 11 lists the available combinations.

Bit INTPOL controls the signal polarity of the INT output (active HIGH or LOW, rising or falling edge). For level-triggering bit INTLVL must be made logic 0. By setting INTLVL to logic 1 an interrupt will generate a pulse of 60 ns (edge-triggering).

Table 9: Interrupt Configuration register: bit allocation

Bit	7	6	5	4	3	2	1	0
Symbol	CDBGMOD[1:0]		DDBGMODIN[1:0]		DDBGMODOUT[1:0]		INTLVL	INTPOL
Reset	03H		03H		03H		0	0
Bus reset	03H		03H		03H		unchanged	unchanged
Access	R/W		R/W		R/W		R/W	R/W

Table 10: Interrupt Configuration register: bit description

Bit	Symbol	Description
7 to 6	CDBGMOD[1:0]	<b>Control 0 Debug Mode:</b> values see Table 11
5 to 4	DDBGMODIN[1:0]	<b>Data Debug Mode IN:</b> values see Table 11
3 to 2	DDBGMODOUT[1:0]	<b>Data Debug Mode OUT:</b> values see Table 11
1	INTLVL	<b>Interrupt Level:</b> selects the signaling mode on output INT (0 = level, 1 = pulsed). In pulsed mode an interrupt produces a 60 ns pulse. Bus reset value: unchanged.
0	INTPOL	<b>Interrupt Polarity:</b> selects signal polarity on output INT (0 = active LOW, 1 = active HIGH). Bus reset value: unchanged.

Table 11: Debug mode settings

Value	CDBGMOD	DDBGMODIN	DDBGMODOUT
00H	Interrupt on all ACK, STALL and NAK	Interrupt on all ACK and NAK	Interrupt on all ACK, STALL, NYET and NAK
01H	Interrupt on all ACK and STALL	Interrupt on ACK	Interrupt on ACK, STALL and NYET
1XH	Interrupt on all ACK, STALL and first NAK <sup>[1]</sup>	Interrupt on all ACK and first NAK <sup>[1]</sup>	Interrupt on all ACK, STALL, NYET and first NAK <sup>[1]</sup>

[1] First NAK: the first NAK on an IN or OUT token after a previous ACK response.

9.2.4 Interrupt Enable register (address: 14H)

This register enables/disables individual interrupt sources. The interrupt for each endpoint can be individually controlled via the associated IEPnRX or IEPnTX bits ('n' representing the endpoint number). All interrupts can be globally disabled via bit GLINTENA in the Mode Register (see Table 7).

An interrupt is generated when the USB SIE receives or generates an ACK, NAK or STALL on the USB bus. The interrupt generation depends on the Debug mode settings of bit fields CDBGMOD, DDBGMODIN and DDBGMODOUT.

All data IN transactions use the Transmit buffers (TX), which are handled by the DDBGMODIN bits. All data OUT transactions go via the Receive buffers (RX), which are handled by the DDBGMODOUT bits. Transactions on Control endpoint 0 (IN, OUT and SETUP) are handled by the CDBGMOD bits.

Interrupts caused by events on the USB bus (SOF, Pseudo SOF, suspend, resume, bus reset, Setup and High Speed Status) can also be controlled individually. A bus reset disables all enabled interrupts except bit IEBRST (bus reset), which remains unchanged.

The Interrupt Enable Register consists of 4 bytes. The bit allocation is given in Table 12.

Table 12: Interrupt Enable register: bit allocation

Bit	31	30	29	28	27	26	25	24
Symbol	reserved	reserved	reserved	reserved	reserved	reserved	IEP7TX	IEP7RX
Reset	0	0	0	0	0	0	0	0
Bus Reset	0	0	0	0	0	0	0	0
Access	R/W	R/W	R/W	R/W	R/W	R/W	R/W	R/W
Bit	23	22	21	20	19	18	17	16
Symbol	IEP6TX	IEP6RX	IEP5TX	IEP5RX	IEP4TX	IEP4RX	IEP3TX	IEP3RX
Reset	0	0	0	0	0	0	0	0
Bus Reset	0	0	0	0	0	0	0	0
Access	R/W	R/W	R/W	R/W	R/W	R/W	R/W	R/W
Bit	15	14	13	12	11	10	9	8
Symbol	IEP2TX	IEP2RX	IEP1TX	IEP1RX	IEP0TX	IEP0RX	reserved	IEP0SETUP
Reset	0	0	0	0	0	0	0	0
Bus Reset	0	0	0	0	0	0	0	0
Access	R/W	R/W	R/W	R/W	R/W	R/W	R/W	R/W
Bit	7	6	5	4	3	2	1	0
Symbol	reserved	IEDMA	IEHS_STA	IERESM	IESUSP	IEPSOF	IESOF	IEBRST
Reset	0	0	0	0	0	0	0	0
Bus Reset	0	0	0	0	0	0	0	unchanged
Access	R/W	R/W	R/W	R/W	R/W	R/W	R/W	R/W



**Table 13: Interrupt Enable register: bit description**

Bit	Symbol	Description
31 to 26	-	reserved; must write logic 0
25 to 12	IEP7TX to IEP1RX	A logic 1 enables interrupt from the indicated endpoint.
11	IEP0TX	A logic 1 enables interrupt from the Control IN endpoint 0.
10	IEP0RX	A logic 1 enables interrupt from the Control OUT endpoint 0.
9	-	reserved
8	IEPOSETUP	A logic 1 enables the interrupt for the Setup data received on endpoint 0.
7	-	reserved
6	IEDMA	A logic 1 enables interrupt upon DMA status change detection.
5	IEHS_STA	A logic 1 enables interrupt upon detection of a High Speed Status change.
4	IERESM	A logic 1 enables interrupt upon detection of a 'resume' state.
3	IESUSP	A logic 1 enables interrupt upon detection of a 'suspend' state.
2	IEPSOF	A logic 1 enables interrupt upon detection of a Pseudo SOF.
1	IESOF	A logic 1 enables interrupt upon detection of an SOF.
0	IEBRST	A logic 1 enables interrupt upon detection of a bus reset.

**9.2.5 DMA Configuration register (address: 38H)**

See [Section 9.4.3](#).

**9.2.6 DMA Hardware register (address: 3CH)**

See [Section 9.4.4](#).

### 9.3 Data flow registers

#### 9.3.1 Endpoint Index register (address: 2CH)

The Endpoint Index register selects a target endpoint for register access by the microcontroller. The register consists of 1 byte and the bit allocation is shown in Table 14. The following registers are indexed:

- Endpoint MaxPacketsize
- Endpoint Type
- Buffer Length
- Data Port
- Short Packet
- Control Function.

For example, to access the OUT data buffer of endpoint 1 via the Data Port register, the Endpoint Index register has to be written first with 02H.

Table 14: Endpoint Index register: bit allocation

Bit	7	6	5	4	3	2	1	0
Symbol	reserved	reserved	EPOSETUP	ENDPIDX[3:0]			DIR	
Reset	0	0	0	00H			0	
Bus reset	0	0	0	00H			0	
Access	R/W	R/W	R/W	R/W			R/W	

Table 15: Endpoint Index register: bit description

Bit	Symbol	Description
7 to 6	-	reserved
5	EPOSETUP	Selects the SETUP buffer for Endpoint 0: <b>0</b> — EP0 data buffer <b>1</b> — SETUP buffer. Must be logic 0 for access to other endpoints than Endpoint 0.
4 to 1	ENDPIDX[3:0]	<b>Endpoint Index:</b> Selects the target endpoint for register access of Buffer Length, Control Function, Data Port, Endpoint Type, MaxPacketSize and Short Packet.
0	DIR	<b>Direction bit:</b> Sets the target endpoint as IN or OUT endpoint: <b>0</b> — target endpoint refers to OUT (RX) FIFO <b>1</b> — target endpoint refers to IN (TX) FIFO.

Table 16: Addressing of Endpoint 0 buffers

Buffer name	EPOSETUP	ENDPIDX	DIR
SETUP	1	00H	0
Data OUT	0	00H	0
Data IN	0	00H	1

### 9.3.2 Control Function register (address: 28H)

The Control Function register is used to perform the buffer management on the endpoints. It consists of 1 byte and the bit configuration is given in Table 17. The register bits can stall, clear or validate any enabled data endpoint. Before accessing this register, the Endpoint Index register must be written first to specify the target endpoint.

Table 17: Control Function register: bit allocation

Bit	7	6	5	4	3	2	1	0
Symbol	reserved	reserved	reserved	CLBUF	VENDP	reserved	STATUS <sup>[1]</sup>	STALL
Reset	0	0	0	0	0	0	0	0
Bus reset	0	0	0	0	0	0	0	0
Access	R/W	R/W	R/W	R/W	R/W	R/W	R/W	R/W

[1] Only applicable for Endpoint 0.

Table 18: Control Function register: bit description

Bit	Symbol	Description
7 to 5	-	reserved.
4	CLBUF	<b>Clear Buffer:</b> A logic 1 clears the RX buffer of the indexed endpoint; the TX buffer is not affected. Before new data can be received, old data in the buffer must be cleared first.
3	VENDP	<b>Validate Endpoint:</b> A logic 1 validates the data in the TX FIFO of an IN endpoint for sending on the next IN token. The FIFO byte count is below or equal to the Endpoint MaxPacketSize.
2	-	reserved
1	STATUS	<b>Status Acknowledge:</b> This bit controls the generation of ACK or NAK during the status stage of a SETUP packet. It is automatically cleared upon completion of the status stage and upon receiving a SETUP token. <b>0</b> — sends NAK <b>1</b> — sends empty packet following IN token (host-to-device) or ACK following OUT token (device-to-host).
0	STALL	<b>Stall Endpoint:</b> A logic 1 stalls the indexed endpoint. This bit is not applicable for isochronous transfers.

### 9.3.3 Data Port register (address: 20H)

This 2-byte register provides direct access for a microcontroller to the FIFO of the indexed endpoint. In case of an 8-bit bus the upper byte is not used. The bit allocation is shown in Table 19.

**Device to host (IN endpoint):** After each write action an internal counter is auto-incremented (by 2 for a 16-bit access, by 1 for an 8-bit access) to the next location in the TX FIFO. When all bytes have been written, the buffer can be validated via the Control Function register (bit VENDP). The data packet will then be sent on the next IN token.

**Host to device (OUT endpoint):** After each read action an internal counter is auto-decremented (by 2 for a 16-bit access, by 1 for an 8-bit access) to the next location in the RX FIFO. When all bytes have been read, the buffer contents can be cleared via the Control Function register (bit CLBUF). A new data packet can then be received on the next OUT token.

**Remark:** The buffer can be validated or cleared automatically by using the Buffer Length register (see [Table 21](#)).

**Table 19: Data Port register: bit allocation**

Bit	15	14	13	12	11	10	9	8
Symbol	DATAPORT[15:8]							
Reset	00H							
Bus reset	00H							
Access	R/W							
Bit	7	6	5	4	3	2	1	0
Symbol	DATAPORT[7:0]							
Reset	00H							
Bus reset	00H							
Access	R/W							

**Table 20: Data Port register: bit description**

Bit	Symbol	Description
15 to 8	DATAPORT[15:8]	data (upper byte); not used in 8-bit bus mode
7 to 0	DATAPORT[7:0]	data (lower byte)

### 9.3.4 Buffer Length register (address: 1CH)

This 2-byte register determines the current packet size (DATACOUNT) of the indexed endpoint FIFO. The bit allocation is given in [Table 21](#).

The Buffer Length register is automatically loaded with the FIFO size, when the Endpoint MaxPacketSize register is written (see [Table 22](#)). A smaller value can be written when required. After a bus reset the Buffer Length register is made zero.

**IN endpoint:** When writing bytes into the TX FIFO, the buffer is automatically validated when DATACOUNT exceeds MaxPacketSize. During the subsequent packet transmission DATACOUNT is decremented with the number of bytes sent. This process is repeated until the number of remaining bytes is less than MaxPacketSize (case I) or zero (case II). In case I, the remaining bytes are automatically validated and a short packet is sent. In case II, a final empty packet will be appended if bit NOEMPKT in the Endpoint Type register is cleared (see [Table 24](#)). Otherwise (if bit NOEMPKT is set), data transfer is considered finished when the buffer is empty.

**OUT endpoint:** The DATACOUNT value is automatically initialized to the number of data bytes sent by the host on each ACK. After reading DATACOUNT bytes from the RX buffer, the buffer is automatically cleared to allow the next packet to be received from the host.

**Remark:** For a 16-bit bus, the last byte of an odd-sized packet is output as the lower byte (LSB).

Table 21: Buffer Length register: bit allocation

Bit	15	14	13	12	11	10	9	8
Symbol	DATACOUNT[15:8]							
Reset	00H							
Bus reset	00H							
Access	R/W							
Bit	7	6	5	4	3	2	1	0
Symbol	DATACOUNT[7:0]							
Reset	00H							
Bus reset	00H							
Access	R/W							

9.3.5 Endpoint MaxPacketSize register (address: 04H)

This register determines the maximum packet size for all endpoints except Control 0. The register contains 2 bytes and the bit allocation is given in Table 22.

Each time the register is written, the Buffer Length registers of all endpoints are re-initialized to the FFOSZ field value. The NTRANS bits control the number of transactions allowed in a single micro-frame (for high-speed operation only).

Table 22: Endpoint MaxPacketSize register: bit allocation

Bit	15	14	13	12	11	10	9	8
Symbol	reserved	reserved	reserved	NTRANS[1:0]		FFOSZ[10:8]		
Reset	0	0	0	00H		00H		
Bus reset	0	0	0	00H		00H		
Access	R/W	R/W	R/W	R/W		R/W		
Bit	7	6	5	4	3	2	1	0
Symbol	FFOSZ[7:0]							
Reset	00H							
Bus reset	00H							
Access	R/W							

Table 23: Endpoint MaxPacketSize register: bit description

Bit	Symbol	Description
15 to 13	reserved	reserved
12 to 11	NTRANS[1:0]	<b>Number of Transactions</b> (HS mode only): 0 — 1 packet per microframe 1 — 2 packets per microframe 2 — 3 packets per microframe 3 — reserved.
10 to 0	FFOSZ[10:0]	<b>FIFO Size:</b> Sets the FIFO size in bytes for the indexed endpoint. Applies to both HS and FS operation. <b>Remark:</b> A FIFO size of zero will disable the endpoint.

### 9.3.6 Endpoint Type register (address: 08C)

This register sets the Endpoint type of the indexed endpoint: control, isochronous, bulk or interrupt. It also serves to enable the endpoint and configure it for double buffering. Automatic generation of an empty packet for a zero length TX buffer can be disabled via bit NOEMPKT. The register contains 2 bytes and the bit allocation is shown in [Table 24](#).

**Table 24: Endpoint Type register: bit allocation**

Bit	15	14	13	12	11	10	9	8
Symbol	reserved							
Reset	00H							
Bus reset	00H							
Access	R/W							
Bit	7	6	5	4	3	2	1	0
Symbol	reserved	reserved	reserved	NOEMPKT	ENABLE	DBLBUF	ENDPTYP[1:0]	
Reset	0	0	0	0	0	0	00H	
Bus reset	0	0	0	0	0	0	00H	
Access	R/W	R/W	R/W	R/W	R/W	R/W	R/W	

**Table 25: Endpoint Type register: bit description**

Bit	Symbol	Description
15 to 5	reserved	reserved.
4	NOEMPKT	<b>No Empty Packet:</b> A logic 0 causes an empty packet to be appended to the next IN token of the USB data, if the Buffer Length register or the Endpoint MaxPacketSize register is zero. A logic 1 disables this function.
3	ENABLE	<b>Endpoint Enable:</b> A logic 1 enables the FIFO of the indexed endpoint. The memory size is allocated as specified in the Endpoint MaxPacketSize register. A logic 0 disables the FIFO.
2	DBLBUF	<b>Double Buffering:</b> A logic 1 enables double buffering for the indexed endpoint. A logic 0 disables double buffering.
1 to 0	ENDPTYP[1:0]	<b>Endpoint Type:</b> These bits select the endpoint type as follows: <b>00H</b> — control <b>01H</b> — isochronous <b>02H</b> — bulk <b>03H</b> — interrupt.

### 9.3.7 Short Packet register (address: 24H)

This read-only register is applicable only for OUT endpoints. It contains 2 bytes and the bit allocation is shown in [Table 26](#).

If the number of bytes of a received packet is less than the value specified in the Endpoint MaxPacketSize register (see [Table 22](#)), the corresponding short packet status bit (OUTnSH) is set. The Short Packet register is updated on every successfully received new packet.

Table 26: Short Packet register: bit allocation

Bit	15	14	13	12	11	10	9	8
Symbol	OUT7SH	OUT6SH	OUT5SH	OUT4SH	OUT3SH	OUT2SH	OUT1SH	OUT0SH
Reset	0	0	0	0	0	0	0	0
Bus reset	0	0	0	0	0	0	0	0
Access	R	R	R	R	R	R	R	R
Bit	7	6	5	4	3	2	1	0
Symbol	reserved	reserved	reserved	reserved	reserved	reserved	reserved	reserved
Reset	0	0	0	0	0	0	0	0
Bus reset	0	0	0	0	0	0	0	0
Access	R/W	R/W	R/W	R/W	R/W	R/W	R/W	R/W

Table 27: Short Packet register: bit description

Bit	Symbol	Description
15	OUT7SH	A logic 1 indicates that a Short Packet was received on OUT endpoint 7. A logic 0 indicates that the buffer is full.
14	OUT6SH	A logic 1 indicates that a Short Packet was received on OUT endpoint 6. A logic 0 indicates that the buffer is full.
13	OUT5SH	A logic 1 indicates that a Short Packet was received on OUT endpoint 5. A logic 0 indicates that the buffer is full.
12	OUT4SH	A logic 1 indicates that a Short Packet was received on OUT endpoint 4. A logic 0 indicates that the buffer is full.
11	OUT3SH	A logic 1 indicates that a Short Packet was received on OUT endpoint 3. A logic 0 indicates that the buffer is full.
10	OUT2SH	A logic 1 indicates that a Short Packet was received on OUT endpoint 2. A logic 0 indicates that the buffer is full.
9	OUT1SH	A logic 1 indicates that a Short Packet was received on OUT endpoint 1. A logic 0 indicates that the buffer is full.
8	OUT0SH	A logic 1 indicates that a Short Packet was received on OUT endpoint 0. A logic 0 indicates that the buffer is full.
7 to 0	-	reserved

## 9.4 DMA registers

Two types of Generic DMA transfer and three types of IDE-specified transfer can be done by writing the proper opcode in the DMA Command Register. The control bits are given in [Table 28](#) (Generic DMA transfers) and [Table 29](#) (IDE-specified transfers).

**GDMA read/write (opcode = 00H/01H)** — Generic DMA Slave mode; the DIOR and DIOW strobe signals are driven by the external DMA Controller.

**MDMA (Master) read/write (opcode = 06H/07H)** — Generic DMA Master mode; the DIOR and DIOW strobe signals are driven by the ISP1581.

**PIO read/write (opcode = 04H/05H)** — PIO mode for IDE transfers; the specification of this mode can be obtained from the *ATA Specification Rev. 4*. DIOR and DIOW are used as data strobes, IORDY can be used by the device to extend the PIO cycle.

**MDMA read/write (opcode = 06H/07H)** — Multiword DMA mode for IDE transfers; the specification of this mode can be obtained from the *ATA Specification Rev. 4*. DIOR and DIOW are used as data strobes, while DREQ and DACK serve as handshake signals.

**UDMA read/write (opcode = 02H/03H)** — Ultra DMA mode for IDE transfers; the specification of this mode can be obtained from the *ATA Specification Rev. 4*. Pins DA0 to DA2, CS0 and CS1 are used to select a device register for access. Control signals are mapped as follows: DREQ (= DMARQ), DACK (= DMACK), DIOW (= STOP), DIOR (= HDMARDY or HSTROBE), IORDY (= DSTROBE or DDMARDY).

**Table 28: Control bits for Generic DMA transfers**

Control bits	Description
<b>GDMA read/write (opcode = 00H/01H)</b>	
DMA Configuration register (see <a href="#">Table 35</a> )	
BURST[2:0]	determines the number of DMA cycles during which pin DREQ is kept asserted
MODE[1:0]	determines the active data strobe(s)
WIDTH0	selects the DMA bus width: 8 or 16 bits
DIS_XFER_CNT	disables the use of the DMA Transfer Counter
ATA_MODE	set to logic 0 (non-ATA transfer)
DMA Hardware register (see <a href="#">Table 37</a> )	
EOT_POL	selects the polarity of the EOT signal
ACK_POL, DREQ_POL, WRITE_POL, READ_POL	select the polarity of the DMA handshake signals
MASTER	set to logic 0 (slave)



**Table 28: Control bits for Generic DMA transfers...continued**

Control bits	Description
<b>MDMA (Master) read/write (opcode = 06H/07H)</b>	
DMA Configuration register (see <a href="#">Table 35</a> )	
UDMA_MODE[1:0]	determines the MDMA timings for the DIOR and DIOW strobes (value 03H is used for UDMA only)
MODE[1:0]	determines the active data strobe(s).
WIDTH	selects the DMA bus width: 8 or 16 bits
DIS_XFER_CNT	disables the use of the DMA Transfer Counter
ATA_MODE	set to logic 1 (ATA transfer)
DMA Hardware register (see <a href="#">Table 37</a> )	
EOT_POL	input EOT is not used
ACK_POL, DREQ_POL, WRITE_POL, READ_POL	select the polarity of the DMA handshake signals
MASTER	set to logic 1 (master)

**Table 29: Control bits for IDE-specified DMA transfers**

Control bits	Description
<b>PIO read/write (opcode = 04H/05H)</b>	
DMA Configuration register (see <a href="#">Table 35</a> )	
PIO_MODE[2:0]	selects the PIO mode; timings are ATA(PI) compatible
ATA_MODE	set to logic 1 (ATA transfer)
DMA Hardware register (see <a href="#">Table 37</a> )	
MASTER	set to logic 0
<b>MDMA read/write (opcode = 06H/07H)</b>	
DMA Configuration register (see <a href="#">Table 35</a> )	
MDMA_MODE[1:0]	selects the MDMA mode; timings are ATA(PI) compatible
ATA_MODE	set to logic 1 (ATA transfer)
DMA Hardware register (see <a href="#">Table 37</a> )	
MASTER	set to logic 0
<b>UDMA Read/Write (opcode = 02H/03H)</b>	
DMA Configuration register (see <a href="#">Table 35</a> )	
UDMA_MODE[1:0]	selects the UDMA mode; timings are ATA(PI) compatible
IGNORE_IORDY	used to ignore the IORDY pin during transfer
ATA_MODE	set to logic 1 (ATA transfer)
DMA Hardware register (see <a href="#">Table 37</a> )	
MASTER	set to logic 0

9.4.1 DMA Command register (address: 30H)

The DMA Command register is a 1-byte register that initiates all DMA transfer activity on the DMA Controller. The register is write-only: reading it will return FFH.

Table 30: DMA Command register: bit allocation

Bit	7	6	5	4	3	2	1	0
Symbol	DMA_CMD[7:0]							
Reset	FFH							
Bus reset	FFH							
Access	W							

Table 31: DMA Command Register: bit description

Bit	Symbol	Description
7:0	DMA_CMD[7:0]	DMA command code, see Table 32.

Table 32: DMA commands

Code (Hex)	Name	Description
00	GDMA Read	<b>Generic DMA IN token transfer (slave mode only):</b> Data is transferred from the external DMA bus to the internal buffer. Strobe: DIOW by external DMA Controller.
01	GDMA Write	<b>Generic DMA OUT token transfer (slave mode only):</b> Data is transferred from the internal buffer to the external DMA bus. Strobe: DIOR by external DMA Controller.
02	UDMA Read	<b>UDMA Read command:</b> Data is transferred from the external DMA to the internal DMA bus.
03	UDMA Write	<b>UDMA Write command:</b> Data is transferred in UDMA mode from the internal buffer to the external DMA bus.
04	PIO Read	<b>PIO Read command for ATAPI device:</b> Data is transferred in PIO mode from the external DMA bus to the internal buffer. Data transfer starts when IORDY is asserted. Inputs DREQ and DACK are ignored.
05	PIO Write	<b>PIO Write command for ATAPI device:</b> Data is transferred in PIO mode from the internal buffer to the external DMA bus. Data transfer starts when IORDY is asserted. Inputs DREQ and DACK are ignored.
06	MDMA Read	<b>Multiword DMA Read:</b> Data is transferred from the external DMA bus to the internal buffer.
07	MDMA Write	<b>Multiword DMA Write:</b> Data is transferred from the internal buffer to the external DMA bus.
0A	Read 1F0	<b>Read at address 01F0H:</b> Initiates a PIO Read cycle from Task File 1F0. Before issuing this command the task file byte count should be programmed at address 1F4H (LSB) and 1F5H (MSB).
0B	Poll BSY	<b>Poll BSY status bit for ATAPI device:</b> Starts repeated PIO Read commands to poll the BSY status bit of the ATAPI device. When BSY = 0, polling is terminated and an interrupt is generated.

Table 32: DMA commands...continued

Code (Hex)	Name	Description
0C	Read Task Files	<b>Read Task Files:</b> Reads all task file registers except 1F0H and 1F7H. When reading has been completed, an interrupt is generated.
0D	-	reserved
0E	Validate Buffer	<b>Validate Buffer (for debugging only):</b> Request from the microcontroller to validate the endpoint buffer following an ATA to USB data transfer.
0F	Clear Buffer	<b>Clear Buffer:</b> Request from the microcontroller to clear the endpoint buffer after a USB to ATA data transfer.
10	Restart	<b>Restart:</b> Request from the microcontroller to move the buffer pointers to the beginning of the endpoint FIFO.
11	Reset DMA	<b>Reset DMA:</b> Initializes the DMA core to its power-on reset state.
12 to FF	-	reserved

#### 9.4.2 DMA Transfer Counter register (address: 34H)

This 4-byte register is used to set up the total byte count of a DMA transfer (DMACR). It indicates the remaining number of bytes left for transfer. The bit allocation is given in [Table 33](#).

The transfer counter is used in DMA modes: PIO (commands: 04H, 05H), UDMA (commands: 02H, 03H), MDMA (commands: 06H, 07H) and GDMA (commands: 00H, 01H).

A new value is written into the register starting with the lower byte (DMACR1) or the lower word (MSB: DMACR2, LSB: DMACR1). Internally, the transfer counter is initialized only after the last byte (DMACR4) has been written.

In the GDMA Slave mode only, the transfer counter can be disabled via bit DIS\_XFER\_CNT in the DMA Configuration Register (see [Table 35](#)). In this case, input EOT can be used to terminate the DMA transfer when data is transferred from the external device to the host via IN tokens. The last packet in the FIFO is validated when pin EOT is asserted. When the host sends data to an external device via OUT tokens, the EOT condition is ignored.

Table 33: DMA Transfer Counter register: bit allocation

<b>Bit</b>	<b>31</b>	<b>30</b>	<b>29</b>	<b>28</b>	<b>27</b>	<b>26</b>	<b>25</b>	<b>24</b>
<b>Symbol</b>	DMACR4 = DMACR[31:24]							
<b>Reset</b>	00H							
<b>Bus reset</b>	00H							
<b>Access</b>	R/W							
<b>Bit</b>	<b>23</b>	<b>22</b>	<b>21</b>	<b>20</b>	<b>19</b>	<b>18</b>	<b>17</b>	<b>16</b>
<b>Symbol</b>	DMACR3 = DMACR[23:16]							
<b>Reset</b>	00H							
<b>Bus reset</b>	00H							
<b>Access</b>	R/W							
<b>Bit</b>	<b>15</b>	<b>14</b>	<b>13</b>	<b>12</b>	<b>11</b>	<b>10</b>	<b>9</b>	<b>8</b>
<b>Symbol</b>	DMACR2 = DMACR[15:8]							
<b>Reset</b>	00H							
<b>Bus reset</b>	00H							
<b>Access</b>	R/W							
<b>Bit</b>	<b>7</b>	<b>6</b>	<b>5</b>	<b>4</b>	<b>3</b>	<b>2</b>	<b>1</b>	<b>0</b>
<b>Symbol</b>	DMACR1 = DMACR[7:0]							
<b>Reset</b>	00H							
<b>Bus reset</b>	00H							
<b>Access</b>	R/W							

Table 34: DMA Transfer Counter register: bit description

Bit	Symbol	Description
31 to 24	DMACR4, DMACR[31:24]	DMA transfer counter byte 4 (MSB)
23 to 16	DMACR3, DMACR[23:16]	DMA transfer counter byte 3
15 to 8	DMACR2, DMACR[15:8]	DMA transfer counter byte 2
7 to 0	DMACR1, DMACR[7:0]	DMA transfer counter byte 1 (LSB)

9.4.3 DMA Configuration register (address: 38H)

This register defines the DMA configuration for the Generic DMA (GDMA) and the Ultra-DMA (UDMA) modes. The DMA Configuration register consists of 2 bytes. The bit allocation is given in Table 35.

Table 35: DMA Configuration register: bit allocation

Bit	15	14	13	12	11	10	9	8
Symbol	reserved	IGNORE_IORDY	ATA_MODE	DMA_MODE[1:0]		PIO_MODE[2:0]		
Reset	0	0	0	00H		00H		
Bus Reset	0	0	0	00H		00H		
Access	R/W	R/W	R/W	R/W		R/W		
Bit	7	6	5	4	3	2	1	0
Symbol	DIS_XFER_CNT	BURST[2:0]		MODE[1:0]		reserved	WIDTH	
Reset	0	00H		00H		0	1	
Bus Reset	0	00H		00H		0	1	
Access	R/W	R/W		R/W		R/W	R/W	

Table 36: DMA Configuration register: bit description

Bit	Symbol	Description
15	-	reserved
14	IGNORE_IORDY	A logic 1 ignores the IORDY input signal (UDMA mode only).
13	ATA_MODE	A logic 1 configures the DMA core for ATA or MDMA mode. Used when issuing DMA commands 02H to 07H, 0AH and 0CH; also used when directly accessing task file registers. A logic 0 configures the DMA core for non-ATA mode. Used when issuing DMA commands 00H and 01H.
12 to 11	UDMA_MODE[1:0]	These bits affect the timing for UDMA and MDMA mode: <b>00H</b> — UDMA/MDMA mode 0: ATA(PI) compatible timings <b>01H</b> — UDMA/MDMA mode 1: ATA(PI) compatible timings <b>02H</b> — UDMA/MDMA mode 2: ATA(PI) compatible timings <b>03H</b> — UDMA mode 3: enables the DMA Strobe Timing register (see Table 39) for non-standard strobe durations; only used in UDMA mode.
10 to 8	PIO_MODE[2:0]	These bits affect the PIO timing (see Table 84): <b>00H to 04H</b> — PIO mode 0 to 4: ATA(PI) compatible timings <b>05H to 07H</b> — reserved.
7	DIS_XFER_CNT	A logic 1 disables the DMA Transfer Counter (see Table 33). The transfer counter can only be disabled in GDMA slave mode; in master mode the counter is always enabled.

Table 36: DMA Configuration register: bit description...continued

Bit	Symbol	Description
6 to 4	BURST[2:0]	<p>These bits select the DMA burst length and the DREQ timing (GDMA Slave mode only):</p> <p><b>00H</b> — DREQ is asserted until the last byte/word is transferred or until the FIFO becomes full or empty</p> <p><b>01H</b> — DREQ is asserted and negated for each byte/word transferred<sup>[1][2]</sup></p> <p><b>02H</b> — DREQ is asserted and negated for every 2 bytes/words transferred<sup>[1][2]</sup></p> <p><b>03H</b> — DREQ is asserted and negated for every 4 bytes/words transferred<sup>[1][2]</sup></p> <p><b>04H</b> — DREQ is asserted and negated for every 8 bytes/words transferred<sup>[1][2]</sup></p> <p><b>05H</b> — DREQ is asserted and negated for every 12 bytes/words transferred<sup>[1][2]</sup></p> <p><b>06H</b> — DREQ is asserted and negated for every 16 bytes/words transferred<sup>[1][2]</sup></p> <p><b>07H</b> — DREQ is asserted and negated for every 32 bytes/words transferred<sup>[1][2]</sup>.</p>
3 to 2	MODE[1:0]	<p>These bits only affect the GDMA (slave) and MDMA (master) handshake signals:</p> <p><b>00H</b> — DIOR (master) or DIOW (slave): strobcs data from the DMA bus into the ISP1581; DIOW (master) or DIOR (slave): puts data from the ISP1581 on the DMA bus</p> <p><b>01H</b> — DIOR (master) or DACK (slave) strobcs the data from the DMA bus into the ISP1581; DACK (master) or DIOR (slave) puts the data from the ISP1581 on the DMA bus</p> <p><b>02H</b> — DACK (master and slave) strobcs the data from the DMA bus into the ISP1581 and also puts the data from the ISP1581 on the DMA bus</p> <p><b>03H</b> — reserved.</p>
1	-	reserved
0	WIDTH	<p>This bit selects the DMA bus width for GDMA (slave) and MDMA (master):</p> <p><b>0</b> — 8-bit data bus</p> <p><b>1</b> — 16-bit data bus.</p>

[1] DREQ is asserted only if space (writing) or data (reading) is available in the FIFO.

[2] This process is stopped when the transfer FIFO becomes empty.

#### 9.4.4 DMA Hardware register (address: 3CH)

The DMA Hardware register consists of 1 byte. The bit allocation is shown in [Table 37](#).

This register determines the polarity of the bus control signals (EOT, DACK, DREQ, DIOR, DIOW) and the DMA mode (master or slave). It also controls whether the upper and lower parts of the data bus are swapped (bits ENDIAN[1:0]), for modes GDMA (slave) and MDMA (master) only.

Table 37: DMA Hardware register: bit allocation (modes GDMA, MDMA (Master) and MDMA (ATA) only)

Bit	7	6	5	4	3	2	1	0
Symbol	ENDIAN[1:0]		EOT_POL	MASTER	ACK_POL	DREQ_POL	WRITE_POL	READ_POL
Reset	00H		0	0	0	1	0	0
Bus reset	00H		0	0	0	1	0	0
Access	R/W		R/W	R/W	R/W	R/W	R/W	R/W

Table 38: DMA Hardware register: bit description

Bit	Symbol	Description
7 to 6	ENDIAN[1:0]	<p>These bits determine whether the data bus is swapped between internal RAM and the DMA bus: nibbles<sup>[1]</sup> (8-bit bus) or bytes (16-bit bus). This only applies for modes GDMA (slave) and MDMA (master).</p> <p><b>00H</b> — normal data representation 8-bit bus: MSN on DATA[7:4], LSN on DATA[3:0]; 16-bit bus: MSB on DATA[15:8], LSB on DATA[7:0]</p> <p><b>01H</b> — swapped data representation 8-bit bus: MSN on DATA[3:0], LSN on DATA[7:4]; 16-bit bus: MSB on DATA[7:0], LSB on DATA[15:8]</p> <p><b>02H, 03H</b> — reserved.</p>
5	EOT_POL	<p>Selects the polarity of the End Of Transfer input (used in GDMA slave mode only):</p> <p><b>0</b> — EOT is active LOW <b>1</b> — EOT is active HIGH.</p>
4	MASTER	<p>Selects the DMA master/slave mode:</p> <p><b>0</b> — GDMA slave mode. <b>1</b> — MDMA master mode.</p>
3	ACK_POL	<p>Selects the DMA acknowledgement polarity:</p> <p><b>0</b> — DACK is active LOW <b>1</b> — DACK is active HIGH.</p>
2	DREQ_POL	<p>Selects the DMA request polarity:</p> <p><b>0</b> — DREQ is active LOW <b>1</b> — DREQ is active HIGH.</p>
1	WRITE_POL	<p>Selects the DIOW strobe polarity.</p> <p><b>0</b> — DIOW is active LOW <b>1</b> — DIOW is active HIGH.</p>
0	READ_POL	<p>Selects the DIOR strobe polarity.</p> <p><b>0</b> — DIOR is active LOW <b>1</b> — DIOR is active HIGH.</p>

[1] Nibble = 4 bits. MSN: Most Significant Nibble, LSN: Least Significant Nibble.

#### 9.4.5 DMA Strobe Timing register (address: 60H)

This 1-byte register controls the strobe timings for UDMA and MDMA mode, when the UDMA\_MODE bits in the DMA Configuration register have been set to 03H. The bit allocation is given in [Table 39](#).

Table 39: DMA Strobe Timing register: bit allocation

Bit	7	6	5	4	3	2	1	0
Symbol	reserved	reserved	reserved	DMA_STROBE_CNT[4:0]				
Reset	0	0	0	1FH				
Bus reset	0	0	0	1FH				
Access	R/W	R/W	R/W	R/W				

Table 40: DMA Strobe Timing register: bit description

Bit	Symbol	Description
7 to 5	-	reserved.
4 to 0	DMA_STROBE_CNT[4:0]	These bits select the strobe duration for UDMA_MODE = 03H (see Table 35). The strobe duration is (N+1) cycles <sup>[1]</sup> , with N representing the value of DMA_STROBE_CNT.

[1] The cycle duration for UDMA mode 3 is the same as for UDMA mode 2 (see Table 87).

#### 9.4.6 Task File registers (addresses: 40H to 4FH)

These registers allow direct access to the internal registers of an ATAPI peripheral using PIO mode. The supported Task File registers and their functions are shown in Table 41. The correct peripheral register is automatically addressed via pins CS1, CS0, DA2, DA1 and DA0 (see Table 42).

Table 41: Task File register functions

Address (Hex)	ATA function	ATAPI function
1F0	data (16-bits)	data (16-bits)
1F1	error/feature	error/feature
1F2	sector count	interrupt reason
1F3	sector number/LBA[7:0]	reserved
1F4	cylinder low/LBA[15:8]	cylinder low
1F5	cylinder high/LBA[23:16]	cylinder high
1F6	drive/head/LBA[27:24]	drive select
1F7	command	status/command
3F6	alternate status/command	alternate status/command
3F7	drive address	reserved

Table 42: ATAPI peripheral register addressing

Task file	CS1	CS0	DA2	DA1	DA0
1F0	H	L	L	L	L
1F1	H	L	L	L	H
1F2	H	L	L	H	L
1F3	H	L	L	H	H
1F4	H	L	H	L	L
1F5	H	L	H	L	H
1F6	H	L	H	H	L



**Table 42: ATAPI peripheral register addressing...continued**

Task file	CS1	CS0	DA2	DA1	DA0
1F7	H	L	H	H	H
3F6	L	H	H	H	L
3F7	L	H	H	H	H

In 8-bit bus mode, the 16-bit Task File register 1F0 requires 2 consecutive write/read accesses before the proper PIO write/read is generated on the IDE interface. The first byte is always the lower byte (LSB). Other task file registers can be accessed directly.

Writing to Task File registers can be done in any order except for Task File register 1F7, which must be written last.

**Table 43: Task File register 1F0 (address: 40H): bit allocation**

CS1 = H, CS0 = L, DA2 = L, DA1 = L, DA0 = L.

Bit	7	6	5	4	3	2	1	0
Symbol	data (ATA or ATAPI)							
Reset	00H							
Bus reset	00H							
Access	R/W							

**Table 44: Task File register 1F1 (address: 48H): bit allocation**

CS1 = H, CS0 = L, DA2 = L, DA1 = L, DA0 = H.

Bit	7	6	5	4	3	2	1	0
Symbol	error/feature (ATA or ATAPI)							
Reset	00H							
Bus reset	00H							
Access	R/W							

**Table 45: Task File register 1F2 (address: 49H): bit allocation**

CS1 = H, CS0 = L, DA2 = L, DA1 = H, DA0 = L.

Bit	7	6	5	4	3	2	1	0
Symbol	sector count (ATA) or interrupt reason (ATAPI)							
Reset	00H							
Bus reset	00H							
Access	R/W							

**Table 46: Task File register 1F3 (address: 4AH): bit allocation**

CS1 = H, CS0 = L, DA2 = L, DA1 = H, DA0 = H.

Bit	7	6	5	4	3	2	1	0
Symbol	sector number/LBA[7:0] (ATA), reserved (ATAPI)							
Reset	00H							
Bus reset	00H							
Access	R/W							

**Table 47: Task File register 1F4 (address: 4BH): bit allocation**

*CS1 = H, CS0 = L, DA2 = H, DA1 = L, DA0 = L.*

Bit	7	6	5	4	3	2	1	0
Symbol	cylinder low/LBA[15:8] (ATA) or cylinder low (ATAPI)							
Reset	00H							
Bus reset	00H							
Access	R/W							

**Table 48: Task File register 1F5 (address: 4CH): bit allocation**

*CS1 = H, CS0 = L, DA2 = H, DA1 = L, DA0 = H.*

Bit	7	6	5	4	3	2	1	0
Symbol	cylinder high/LBA[23:16] (ATA) or cylinder high (ATAPI)							
Reset	00H							
Bus reset	00H							
Access	R/W							

**Table 49: Task File register 1F6 (address: 4DH): bit allocation**

*CS1 = H, CS0 = L, DA2 = H, DA1 = H, DA0 = L.*

Bit	7	6	5	4	3	2	1	0
Symbol	drive/head/LBA[27:24] (ATA) or drive (ATAPI)							
Reset	00H							
Bus reset	00H							
Access	R/W							

**Table 50: Task File register 1F7 (address: 44H): bit allocation**

*CS1 = H, CS0 = L, DA2 = H, DA1 = H, DA0 = H.*

Bit	7	6	5	4	3	2	1	0
Symbol	command (ATA) or status <sup>[1]</sup> /command (ATAPI)							
Reset	00H							
Bus reset	00H							
Access	W							

[1] Task File register 1F7 is a write-only register; a read will return 00H.

**Table 51: Task File register 3F6 (address: 4EH): bit allocation**

*CS1 = L, CS0 = H, DA2 = H, DA1 = H, DA0 = L.*

Bit	7	6	5	4	3	2	1	0
Symbol	alternate status/command (ATA or ATAPI)							
Reset	00H							
Bus reset	00H							
Access	R/W							

**Table 52: Task File register 3F7 (address: 4FH): bit allocation**

CS1 = L, CS0 = H, DA2 = H, DA1 = H, DA0 = H.

Bit	7	6	5	4	3	2	1	0
Symbol	drive address (ATA) or reserved (ATAPI)							
Reset	00H							
Bus reset	00H							
Access	R/W							

#### 9.4.7 DMA Interrupt Reason register (address: 50H)

This 2-byte register shows the source(s) of a DMA interrupt. Each bit is refreshed after a DMA command has been executed. An interrupt source is cleared by writing a logic 1 to the corresponding bit. The bit allocation is given in [Table 53](#).

**Table 53: DMA Interrupt Reason register: bit allocation**

Bit	15	14	13	12	11	10	9	8
Symbol	reserved	reserved	reserved	reserved	reserved	reserved	INTRQ_ PENDING	DMA_ XFER_OK
Reset	0	0	0	0	0	0	0	0
Bus reset	0	0	0	0	0	0	0	0
Access	R/W	R/W	R/W	R/W	R/W	R/W	R/W	R/W
Bit	7	6	5	4	3	2	1	0
Symbol	1F0_WF_E	1F0_WF_F	1F0_RF_E	READ_1F0	BSY_ DONE	TF_RD_ DONE	CMD_ INTRQ_OK	reserved
Reset	0	0	0	0	0	0	0	0
Bus reset	0	0	0	0	0	0	0	0
Access	R/W	R/W	R/W	R/W	R/W	R/W	R/W	R/W

**Table 54: DMA Interrupt Reason Register: bit description**

Bit	Symbol	Description
15 to 10	-	reserved
9	INTRQ_PENDING	A logic 1 indicates that a pending interrupt was detected on pin INTRQ.
8	DMA_XFER_OK	A logic 1 indicates that the DMA transfer has been completed (DMA Transfer Counter has become zero). This bit is only used in GDMA (slave) mode and MDMA (master) mode.
7	1F0_WF_E	A logic 1 indicates that the 1F0 write FIFO is empty and the microcontroller can start writing data.
6	1F0_WF_F	A logic 1 indicates that the 1F0 write FIFO is full and the microcontroller must stop writing data.
5	1F0_RF_E	A logic 1 indicates that 1F0 read FIFO is empty and the microcontroller must stop reading data.
4	READ_1F0	A logic 1 indicates that 1F0 FIFO contains unread data and the microcontroller can start reading data.
3	BSY_DONE	A logic 1 indicates that the BSY status bit has become zero and polling has been stopped.

**Table 54: DMA Interrupt Reason Register: bit description...continued**

Bit	Symbol	Description
2	TF_RD_DONE	A logic 1 indicates that the Read Task Files command has been completed.
1	CMD_INTRQ_OK	A logic 1 indicates that all bytes from the FIFO have been transferred (DMA Transfer Count zero) and an interrupt on pin INTRQ was detected.
0	-	reserved

**9.4.8 DMA Interrupt Enable register (address: 54H)**

This 2-byte register controls the interrupt generation of the source bits in the DMA Interrupt Reason register (see Table 53). The bit allocation is given in Table 55. A logic 1 enables interrupt generation. The value after a (bus) reset is logic 0 (disabled).

**Table 55: DMA Interrupt Enable register: bit allocation**

Bit	15	14	13	12	11	10	9	8
Symbol	reserved	reserved	reserved	reserved	reserved	reserved	IE_INTRQ_PENDING	IE_DMA_XFER_OK
Reset	0	0	0	0	0	0	0	0
Bus reset	0	0	0	0	0	0	0	0
Access	R/W	R/W	R/W	R/W	R/W	R/W	R/W	R/W
Bit	7	6	5	4	3	2	1	0
Symbol	IE_1F0_WF_E	IE_1F0_WF_F	IE_1F0_RF_E	IE_READ_1F0	IE_BSY_DONE	IE_TF_RD_DONE	IE_CMD_INTRQ_OK	reserved
Reset	0	0	0	0	0	0	0	0
Bus reset	0	0	0	0	0	0	0	0
Access	R/W	R/W	R/W	R/W	R/W	R/W	R/W	R/W

**9.4.9 DMA Endpoint register (address: 58H)**

This 1-byte register selects a USB endpoint FIFO as a source or destination for DMA transfers. The bit allocation is given in Table 56.

**Table 56: DMA Endpoint register: bit allocation**

Bit	7	6	5	4	3	2	1	0
Symbol	reserved	reserved	reserved	reserved		EPIDX[2:0]		DMADIR
Power Reset	0	0	0	0	0	0	0	0
Bus Reset	0	0	0	0	0	0	0	0
Access	R/W	R/W	R/W	R/W	R/W	R/W	R/W	R/W

**Table 57: DMA Endpoint register: bit description**

Bit	Symbol	Description
7 to 4	-	reserved
3 to 1	EPIDX[2:0]	selects the indicated endpoint for DMA access
0	DMADIR	<b>0</b> — selects the RX/OUT FIFO for DMA read transfers <b>1</b> — selects the TX/IN FIFO for DMA write transfers.

## 9.5 General registers

### 9.5.1 Interrupt register (address: 18H)

The Interrupt register consists of 4 bytes. The bit allocation is given in [Table 58](#).

When a bit is set in the Interrupt register, this indicates that the hardware condition for an interrupt has occurred. When the Interrupt register content is non-zero, the INT output will be asserted. Upon detecting the interrupt, the external microprocessor must read the Interrupt register to determine the source of the interrupt.

Each endpoint buffer has a dedicated interrupt bit (EPnTX, EPnRX). In addition, various bus states can generate an interrupt: Resume, Suspend, Pseudo-SOF, SOF and Bus Reset. The DMA Controller only has one interrupt bit: the source for a DMA interrupt is shown in the DMA Interrupt Reason register (see [Table 53](#)).

Each interrupt bit (except bit DMA) can be individually cleared by writing a logic 1. The DMA interrupt bit can be cleared by writing a logic 1 to the related interrupt source bit in the DMA Interrupt Reason register.

**Table 58: Interrupt register: bit allocation**

Bit	31	30	29	28	27	26	25	24
Symbol	reserved	reserved	reserved	reserved	reserved	reserved	EP7TX	EP7RX
Reset	0	0	0	0	0	0	0	0
Bus reset	0	0	0	0	0	0	0	0
Access	R/W	R/W	R/W	R/W	R/W	R/W	R/W	R/W
Bit	23	22	21	20	19	18	17	16
Symbol	EP6TX	EP6RX	EP5TX	EP5RX	EP4TX	EP4RX	EP3TX	EP3RX
Reset	0	0	0	0	0	0	0	0
Bus reset	0	0	0	0	0	0	0	0
Access	R/W	R/W	R/W	R/W	R/W	R/W	R/W	R/W
Bit	15	14	13	12	11	10	9	8
Symbol	EP2TX	EP2RX	EP1TX	EP1RX	EP0TX	EP0RX	reserved	EP0SETUP
Reset	0	0	0	0	0	0	0	0
Bus reset	0	0	0	0	0	0	0	0
Access	R/W	R/W	R/W	R/W	R/W	R/W	R/W	R/W
Bit	7	6	5	4	3	2	1	0
Symbol	reserved	DMA	HS_STAT	RESUME	SUSP	PSOF	SOF	BRESET
Reset	0	0	0	0	0	0	0	0
Bus reset	0	0	0	0	0	0	0	unchanged
Access	R/W	R/W	R/W	R/W	R/W	R/W	R/W	R/W

**Table 59: Interrupt register: bit description**

Bit	Symbol	Description
31 to 26	reserved	reserved; must write logic 0
25	EP7TX	A logic 1 indicates the Endpoint 7 TX buffer as interrupt source.
24	EP7RX	A logic 1 indicates the Endpoint 7 RX buffer as interrupt source.
23	EP6TX	A logic 1 indicates the Endpoint 6 TX buffer as interrupt source.

Table 59: Interrupt register: bit description...continued

Bit	Symbol	Description
22	EP6RX	A logic 1 indicates the Endpoint 6 RX buffer as interrupt source.
21	EP5TX	A logic 1 indicates the Endpoint 5 TX buffer as interrupt source.
20	EP5RX	A logic 1 indicates the Endpoint 5 RX buffer as interrupt source.
19	EP4TX	A logic 1 indicates the Endpoint 4 TX buffer as interrupt source.
18	EP4RX	A logic 1 indicates the Endpoint 4 RX buffer as interrupt source.
17	EP3TX	A logic 1 indicates the Endpoint 3 TX buffer as interrupt source.
16	EP3RX	A logic 1 indicates the Endpoint 3 RX buffer as interrupt source.
15	EP2TX	A logic 1 indicates the Endpoint 2 TX buffer as interrupt source.
14	EP2RX	A logic 1 indicates the Endpoint 2 RX buffer as interrupt source.
13	EP1TX	A logic 1 indicates the Endpoint 1 TX buffer as interrupt source.
12	EP1RX	A logic 1 indicates the Endpoint 1 RX buffer as interrupt source.
11	EP0TX	A logic 1 indicates the Endpoint 0 data TX buffer as interrupt source.
10	EP0RX	A logic 1 indicates the Endpoint 0 data RX buffer as interrupt source.
9	reserved	reserved.
8	EP0SETUP	A logic 1 indicates that a SETUP token was received on Endpoint 0.
7	reserved	reserved.
6	DMA	<b>DMA status:</b> A logic 1 indicates a change in the DMA Status register.
5	HS_STAT	<b>High Speed Status:</b> A logic 1 indicates a change from FS to HS mode (HS connection). This bit is not set, when the system goes into a FS suspend.
4	RESUME	<b>Resume status:</b> A logic 1 indicates that a status change from 'suspend' to 'resume' (active) was detected.
3	SUSP	<b>Suspend status:</b> A logic 1 indicates that a status change from active to 'suspend' was detected on the bus.
2	PSOF	<b>Pseudo SOF interrupt:</b> A logic 1 indicates that a Pseudo SOF or $\mu$ SOF was received. Pseudo SOF is an internally generated clock signal (FS: 1 ms period, HS: 125 $\mu$ s period) synchronized to the USB bus SOF/ $\mu$ SOF.
1	SOF	<b>SOF interrupt:</b> A logic 1 indicates that a SOF/ $\mu$ SOF was received.
0	BRESET	<b>Bus Reset:</b> A logic 1 indicates that a USB bus reset was detected.

### 9.5.2 Chip ID register (address: 70H)

This read-only register contains the chip identification and the hardware version numbers. The firmware should check this information to determine the functions and features supported. The register contains 3 bytes and the bit allocation is shown in [Table 60](#).

Table 60: Chip ID register: bit allocation

Bit	23	22	21	20	19	18	17	16
Symbol	VERSION[7:0]							
Reset	01H							
Bus reset	01H							
Access	R							
Bit	15	14	13	12	11	10	9	8
Symbol	CHIPID[15:8]							
Reset	15H							
Bus reset	15H							
Access	R							
Bit	7	6	5	4	3	2	1	0
Symbol	CHIPID[7:0]							
Reset	81H							
Bus reset	81H							
Access	R							

Table 61: Chip ID Register: bit description

Bit	Symbol	Description
23 to 16	VERSION	Version number (01H). The version number will be incremented in case of a silicon revision with improved performance and functionality.
15 to 8	CHIPID[15:8]	Chip ID: upper byte (15H)
7 to 0	CHIPID[7:0]	Chip ID: lower byte (81H)

9.5.3 Frame Number register (address: 74H)

This read-only register contains the frame number of the last successfully received Start Of Frame (SOF). The register contains 2 bytes and the bit allocation is given in Table 62. In case of 8-bit access the register content is returned lower byte first.

Table 62: Frame Number register: bit allocation

Bit	15	14	13	12	11	10	9	8
Symbol	reserved	reserved	MICROSOF[2:0]			SOFR[10:8]		
Power Reset	0	0	00H			00H		
Bus Reset	0	0	00H			00H		
Access	R	R	R			R		
Bit	7	6	5	4	3	2	1	0
Symbol	SOFR[7:0]							
Power Reset	00H							
Bus Reset	00H							
Access	R							

**Table 63: Frame Number register: bit description**

Bit	Symbol	Description
13 to 11	MICROSOF[2:0]	microframe number
10 to 0	SOFR[10:0]	frame number

#### 9.5.4 Scratch register (address: 78H)

This 16-bit register can be used by the firmware to save and restore information, e.g. the device status before it enters power-off mode during 'suspend'. The content of this register will not be altered by a bus reset. The bit allocation is given in [Table 64](#).

**Table 64: Scratch Register: bit allocation**

Bit	15	14	13	12	11	10	9	8
Symbol								SFIRH[7:0]
Reset								00H
Bus reset								unchanged
Access								R/W
Bit	7	6	5	4	3	2	1	0
Symbol								SFIRL[7:0]
Reset								00H
Bus reset								unchanged
Access								R/W

**Table 65: Scratch Information register: bit description**

Bit	Symbol	Description
15 to 8	SFIRH[7:0]	scratch firmware information register (high byte)
7 to 0	SFIRL[7:0]	scratch firmware information register (low byte)

#### 9.5.5 Unlock Device register (address: 7CH)

In 'suspend' state all the internal registers are write-protected to prevent data corruption by external devices during a 'resume'. Register access for reading is not blocked.

To re-enable the ISP1581 registers from the write-protected mode, the firmware must write a 2-byte unlock code (AA37H) into this register. The bit allocation of the Unlock Device register is given in [Table 66](#).



Table 66: Unlock Device register: bit allocation

Bit	15	14	13	12	11	10	9	8
Symbol	ULCODE[15:8] = AAH							
Reset	not applicable							
Bus reset	not applicable							
Access	W							
Bit	7	6	5	4	3	2	1	0
Symbol	ULCODE[7:0] = 37H							
Reset	not applicable							
Bus reset	not applicable							
Access	W							

Table 67: Unlock Device register: bit description

Bit	Symbol	Description
15 to 0	ULCODE[15:0]	Writing data AA37H unlocks the internal registers and FIFOs for writing, following a 'resume'.

### 9.5.6 Test Mode register (address: 84H)

This 1-byte register allows the firmware to set the (D+, D-) lines to predetermined states for testing purposes. The bit allocation is given in Table 68.

**Remark:** Only one bit can be set at a time.

Table 68: Test Mode register: bit allocation

Bit	7	6	5	4	3	2	1	0
Symbol	FORCEHS	PHYTEST	LPBK	FORCEFS	PRBS	KSTATE	JSTATE	SEO_NAK
Reset	0	0	0	0	0	0	0	0
Bus reset	0	0	0	0	0	0	0	0
Access	R/W	R/W	R/W	R/W	R/W	R/W	R/W	R/W

Table 69: Test Mode Register: bit description

Bit	Symbol	Description
7	FORCEHS	A logic 1 forces the hardware to high-speed mode only and disables the chirp detection logic.
6	PHYTEST	A logic 1 initiates an internal hardware test of the transceiver. After successful completion the PHYTEST bit reverts to logic 0.
5	LPBK	A logic 1 selects loop-back mode. All data written to TX/IN FIFO of endpoint 1 is copied into RX/OUT of endpoint 1.
4	FORCEFS	A logic 1 forces the physical layer to full-speed mode only and disables the chirp detection logic.
3	PRBS	A logic 1 sets the (D+, D-) lines to toggle in a pre-determined random pattern.
2	KSTATE	Writing a logic 1 sets the (D+, D-) lines to the K state.
1	JSTATE	Writing a logic 1 sets the (D+, D-) lines to the J state.
0	SEO_NAK	Writing a logic 1 sets the (D+, D-) lines to a HS quiescent state. The device only responds to a valid HS IN token with a NAK.

## 10. Limiting values

**Table 70: Absolute maximum ratings**

In accordance with the Absolute Maximum Rating System (IEC 60134).

Symbol	Parameter	Conditions	Min.	Max	Unit
$V_{CC}$	supply voltage		-0.5	+6.0	V
$V_I$	input voltage		-0.5	$V_{CC} + 0.5$	V
$I_{latchup}$	latchup current	$V_I < 0$ or $V_I > V_{CC}$	-	200	mA
$V_{esd}$	electrostatic discharge voltage	$I_{LI} < 15 \mu A$	-	<tbd>	V
$T_{stg}$	storage temperature		-60	+150	°C
$P_{tot}$	total power dissipation		-	<tbd>	mW

**Table 71: Recommended operating conditions**

Symbol	Parameter	Conditions	Min.	Max	Unit
$V_{CC}$	supply voltage	with voltage converter	4.0	5.5	V
		without voltage converter	3.0	3.6	V
$V_I$	input voltage range		0	5.5	V
$V_{I(AI/O)}$	input voltage on analog I/O pins (D+, D-)		0	3.6	V
$V_{O(od)}$	open-drain output pull-up voltage		0	$V_{CC}$	V
$T_{amb}$	operating ambient temperature		-40	+85	°C

## 11. Static characteristics

**Table 72: Static characteristics; supply pins**

$V_{CC} = 4.0$  to  $5.5$  V;  $V_{GND} = 0$  V;  $T_{amb} = -40$  to  $+85$  °C; unless otherwise specified.

Symbol	Parameter	Conditions	Min.	Typ	Max	Unit
$V_{reg(3.3)}$	regulated supply voltage	with voltage converter	3.0 <sup>[1]</sup>	3.3	3.6	V
$I_{CC}$	operating supply current		-	<tbd>	-	mA
$I_{CC(susp)}$	suspend supply current	1.5 kΩ pull-up on pin D+	-	-	<tbd>	μA
		no pull-up on pin D+	-	-	<tbd>	μA

[1] In 'suspend' mode the minimum voltage is 3.0 V.

**Table 73: Static characteristics; digital pins**

$V_{CC} = 4.0$  to  $5.5$  V;  $V_{GND} = 0$  V;  $T_{amb} = -40$  to  $+85$  °C; unless otherwise specified.

Symbol	Parameter	Conditions	Min.	Typ	Max	Unit
<b>Input levels</b>						
$V_{IL}$	LOW-level input voltage		-	-	0.8	V
$V_{IH}$	HIGH-level input voltage		2.0	-	-	V

**Table 73: Static characteristics: digital pins...continued** $V_{CC} = 4.0$  to  $5.5$  V;  $V_{GND} = 0$  V;  $T_{amb} = -40$  to  $+85$  °C; unless otherwise specified.

Symbol	Parameter	Conditions	Min.	Typ	Max	Unit
<b>Schmitt trigger inputs</b>						
$V_{th(LH)}$	positive-going threshold voltage		1.4	-	1.9	V
$V_{th(HL)}$	negative-going threshold voltage		0.9	-	1.5	V
$V_{hys}$	hysteresis voltage		0.4	-	0.7	V
<b>Output levels</b>						
$V_{OL}$	LOW-level output voltage (open drain outputs)	$I_{OL} = \text{rated drive}$	-	-	0.4	V
		$I_{OL} = 20 \mu\text{A}$	-	-	0.1	V
$V_{OH}$	HIGH-level output voltage (open drain outputs)	$I_{OH} = \text{rated drive}$	2.4	-	-	V
		$I_{OH} = 20 \mu\text{A}$	$V_{CC}-0.1$	-	-	V
<b>Leakage current</b>						
$I_{LI}$	input leakage current		-	-	$\pm 5$	$\mu\text{A}$
<b>Open-drain outputs</b>						
$I_{OZ}$	OFF-state output current		-	-	$\pm 5$	$\mu\text{A}$

**Table 74: Static characteristics: analog I/O pins (D+, D-)<sup>[1]</sup>** $V_{CC} = 4.0$  to  $5.5$  V;  $V_{GND} = 0$  V;  $T_{amb} = -40$  to  $+85$  °C; unless otherwise specified.

Symbol	Parameter	Conditions	Min.	Typ	Max	Unit
<b>Input levels</b>						
$V_{DI}$	differential input sensitivity	$ V_{I(D+)} - V_{I(D-)} $	0.2	-	-	V
$V_{CM}$	differential common mode voltage	includes $V_{DI}$ range	0.8	-	2.5	V
$V_{SE}$	single ended receiver threshold		0.8	-	2.0	V
$V_{IL}$	LOW-level input voltage		-	-	0.8	V
$V_{IH}$	HIGH-level input voltage		2.0	-	-	V
<b>Output levels</b>						
$V_{OL}$	LOW-level output voltage	$R_L = 1.5 \text{ k}\Omega$ to $+3.6\text{V}$	-	-	0.3	V
$V_{OH}$	HIGH-level output voltage	$R_L = 15 \text{ k}\Omega$ to GND	2.8	-	3.6	V
<b>Leakage current</b>						
$I_{LZ}$	OFF-state leakage current	$0 < V_I < 3.3 \text{ V}$	-	-	$\pm 10$	$\mu\text{A}$
<b>Capacitance</b>						
$C_{IN}$	transceiver capacitance	pin to GND	-	-	20	pF
<b>Resistance</b>						
$R_{PU}$	pull-up resistance on D+	SoftConnect = ON	1.1	-	1.9	k $\Omega$
$Z_{DRV}$ <sup>[2]</sup>	driver output impedance	steady-state drive	29	-	44	$\Omega$
$Z_{INP}$	input impedance		10	-	-	M $\Omega$

[1] D+ is the USB positive data pin; D- is the USB negative data pin.

[2] Includes external resistors of  $22 \Omega \pm 1\%$  on both D+ and D-.

## 12. Dynamic characteristics

**Table 75: Dynamic characteristics**

$V_{CC} = 4.0$  to  $5.5$  V;  $V_{GND} = 0$  V;  $T_{amb} = -40$  to  $+85$  °C; unless otherwise specified.

Symbol	Parameter	Conditions	Min.	Typ	Max	Unit
<b>Reset</b>						
$t_{W(\overline{\text{RESET}})}$	pulse width on input $\overline{\text{RESET}}$	crystal oscillator running	<tdb>	-	-	$\mu\text{s}$
		crystal oscillator stopped	-	<tdb> <sup>[1]</sup>	-	ms
<b>Crystal oscillator</b>						
$f_{\text{XTAL}}$	crystal frequency		-	12	-	MHz

[1] Dependent on the crystal oscillator start-up time.

**Table 76: Dynamic characteristics: analog I/O pins (D+, D-)<sup>[1]</sup>**

$V_{CC} = 4.0$  to  $5.5$  V;  $V_{GND} = 0$  V;  $T_{amb} = -40$  to  $+85$  °C;  $C_L = 50$  pF;  $R_{PU} = 1.5$  k $\Omega$  on D+ to  $V_{\text{TERM}}$ .; unless otherwise specified.

Symbol	Parameter	Conditions	Min.	Typ	Max	Unit
<b>Driver characteristics</b>						
<b>Full-speed mode</b>						
$t_{\text{FR}}$	rise time	$C_L = 50$ pF; 10 to 90% of $ V_{\text{OH}} - V_{\text{OL}} $	4	-	20	ns
$t_{\text{FF}}$	fall time	$C_L = 50$ pF; 90 to 10% of $ V_{\text{OH}} - V_{\text{OL}} $	4	-	20	ns
FRFM	differential rise/fall time matching ( $t_{\text{FR}}/t_{\text{FF}}$ )		<sup>[2]</sup> 90	-	111.11	%
$V_{\text{CRS}}$	output signal crossover voltage		<sup>[2][3]</sup> 1.3	-	2.0	V
<b>High-speed mode</b>						
$t_{\text{HSR}}$	high-speed differential rise time	with captive cable	500	-	-	ps
$t_{\text{HSF}}$	high-speed differential fall time	with captive cable	500	-	-	ps
<b>Data source timing</b>						
<b>High-speed mode (Template 1, Universal Serial Bus Specification Rev. 2.0)</b>						
-	driver waveform requirements	eye patterns of Template 1 and Template 2; see Figure 7 and Figure 8	<sup>[3]</sup>	see Table 77		
<b>Full-speed mode</b>						
$t_{\text{FEOPT}}$	source EOP width	see Figure 3	<sup>[3]</sup> 160	-	175	ns
$t_{\text{FDEOP}}$	source differential data-to-EOP transition skew	see Figure 3	<sup>[3]</sup> -2	-	+5	ns

**Table 76: Dynamic characteristics: analog I/O pins (D+, D-)<sup>[1]...continued</sup>**

$V_{CC} = 4.0$  to  $5.5$  V;  $V_{GND} = 0$  V;  $T_{amb} = -40$  to  $+85$  °C;  $C_L = 50$  pF;  $R_{PU} = 1.5$  kΩ on D+ to  $V_{TERM.}$ ; unless otherwise specified.

Symbol	Parameter	Conditions	Min.	Typ	Max	Unit
<b>Receiver timing</b>						
High-speed mode (Template 4, <i>Universal Serial Bus Specification Rev. 2.0</i> )						
-	data source jitter and receiver jitter tolerance	eye patterns of Template 3 and Template 4; see Figure 9 and Figure 10	[3]	see Table 80		
<b>Full-speed mode</b>						
t <sub>JR1</sub>	receiver data jitter tolerance to next transition	see Figure 4	[3] -18.5	-	+18.5	ns
t <sub>JR2</sub>	receiver data jitter tolerance for paired transitions	see Figure 4	[3] -9	-	+9	ns
t <sub>FEOPR</sub>	receiver SE0 width	accepted as EOP; see Figure 3	[3] 82	-	-	ns
t <sub>FST</sub>	width of SE0 during differential transition	rejected as EOP; see Figure 5	[3] -	-	14	ns

- [1] Test circuit: see Figure 31.
- [2] Excluding the first transition from Idle state.
- [3] Characterized only, not tested. Limits guaranteed by design.

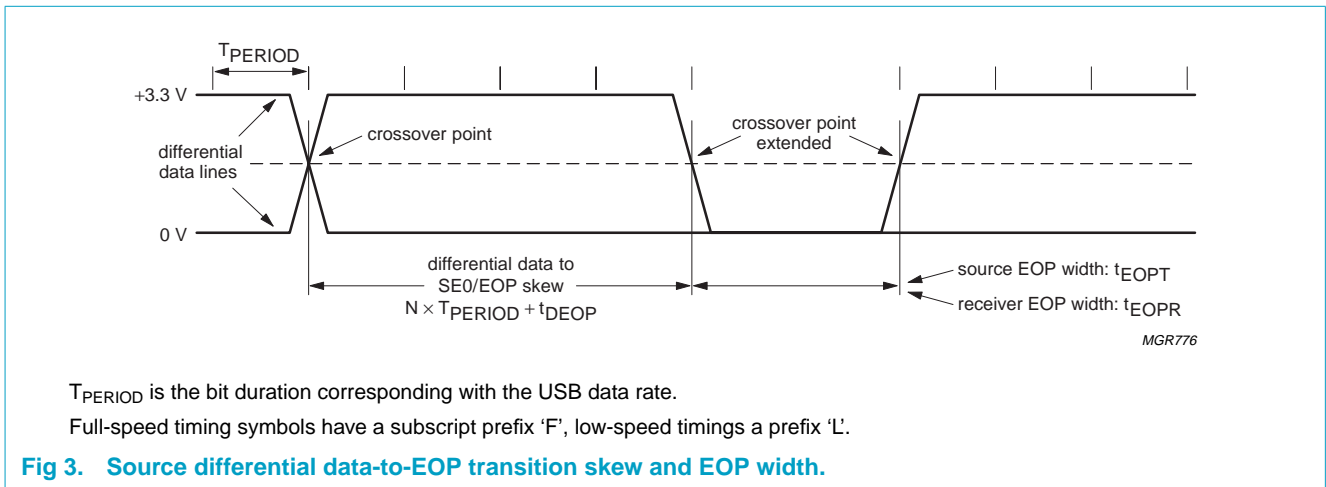

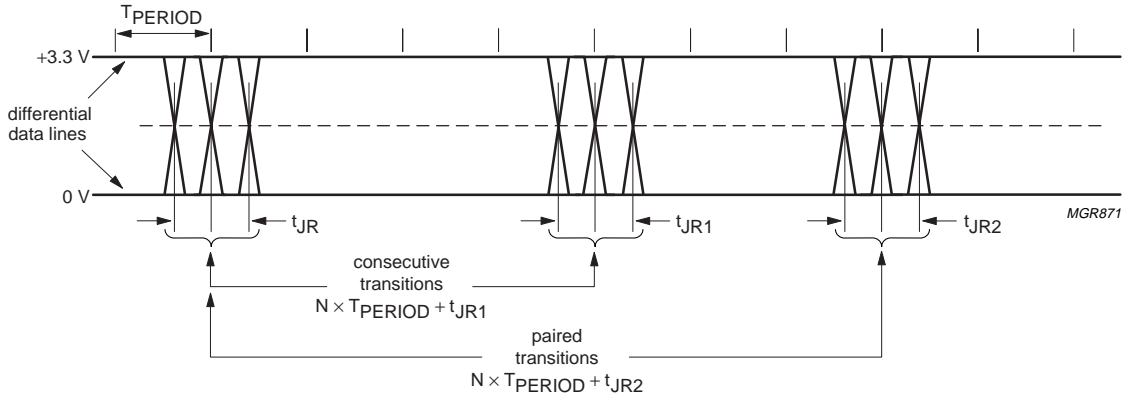

$T_{PERIOD}$  is the bit duration corresponding with the USB data rate.

Fig 4. Receiver differential data jitter.

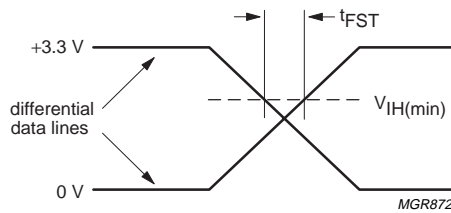

Fig 5. Receiver SE0 width tolerance.

### 12.1 High-speed signals

High-speed USB signals are characterized using eye patterns. For measuring the eye patterns 4 test points have been defined (see Figure 6). The *Universal Serial Bus Specification Rev. 2.0* defines the eye patterns in several 'templates'. For ISP1581 Templates 1, 2, 3 and 4 are relevant.

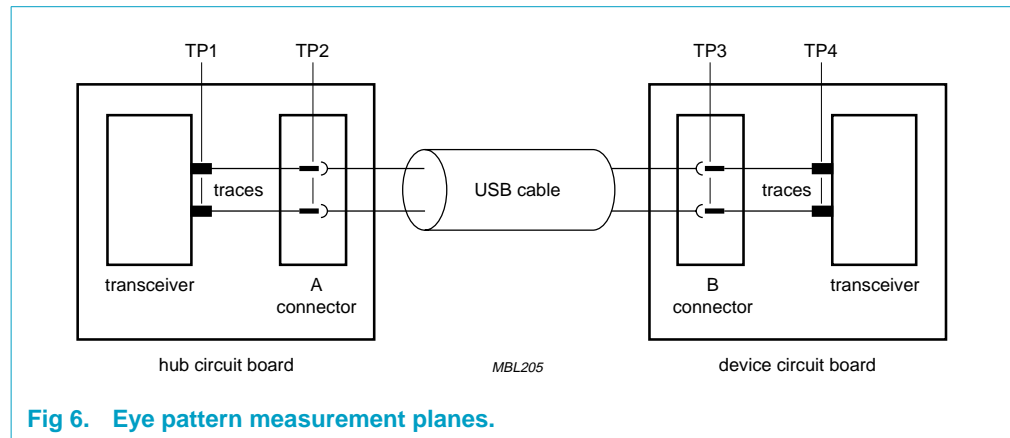

Fig 6. Eye pattern measurement planes.

12.1.1 Template 1 (transmit waveform; device without captive cable)

The eye pattern in Figure 7 defines the transmit waveform requirements for a hub (measured at TP2) or a device without a captive<sup>1</sup> cable (measured at TP3). The corresponding signal levels and timings are given in Table 77. Timings are given as a percentage of the unit interval (UI), which represents the nominal bit duration  $T_{PERIOD}$  for a 480 Mbit/s transmission rate.

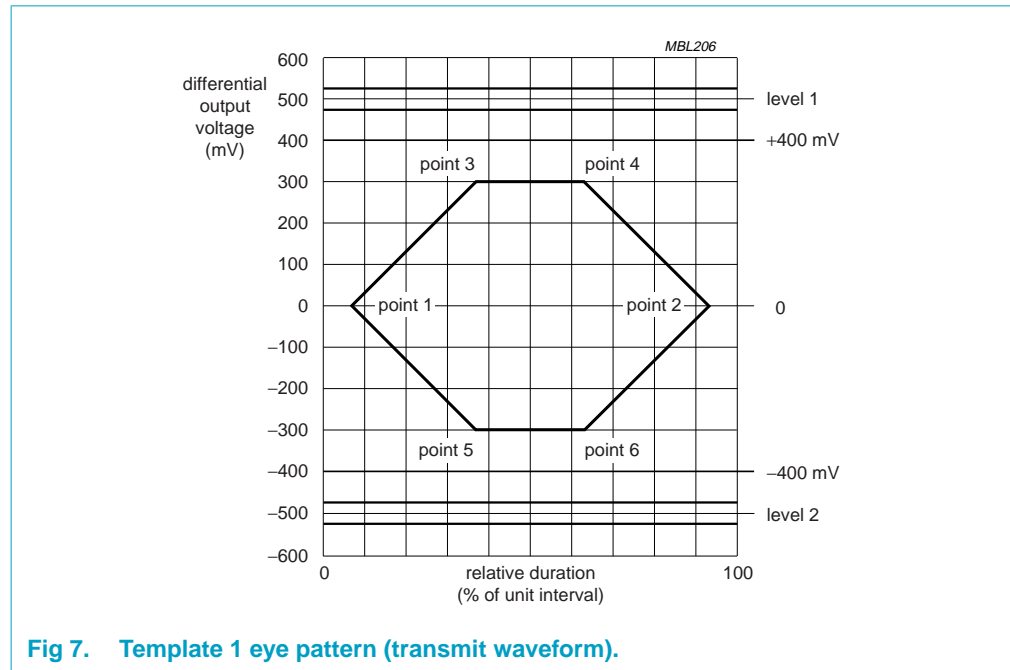

Fig 7. Template 1 eye pattern (transmit waveform).

Table 77: Template 1 eye pattern definition

Name	Differential voltage on DP, DM (mV)	Relative duration (% of unit interval)
Level 1	+525 [1]	n.a.
	+475 [2]	
Level 2	-525 [1]	n.a.
	-475 [2]	
Point 1	0	7.5
Point 2	0	92.5
Point 3	+300	37.5
Point 4	+300	62.5
Point 5	-300	37.5
Point 6	-300	62.5

[1] In the unit interval following a transition.

[2] In all other cases.

1. Captive cables have a vendor-specific connector to the peripheral (hardwired or detachable) and a USB “A” connector on the other side. For hot plugging, the vendor-specific connector must meet the same performance requirements as a USB “B” connector.

12.1.2 Template 2 (transmit waveform; device with captive cable)

The eye pattern in Figure 8 defines the transmit waveform requirements for a device with a captive cable (measured at TP2). The corresponding signal levels and timings are given in Table 78. Timings are given as a percentage of the unit interval (UI), which represents the nominal bit duration  $T_{PERIOD}$  for a 480 Mbit/s transmission rate.

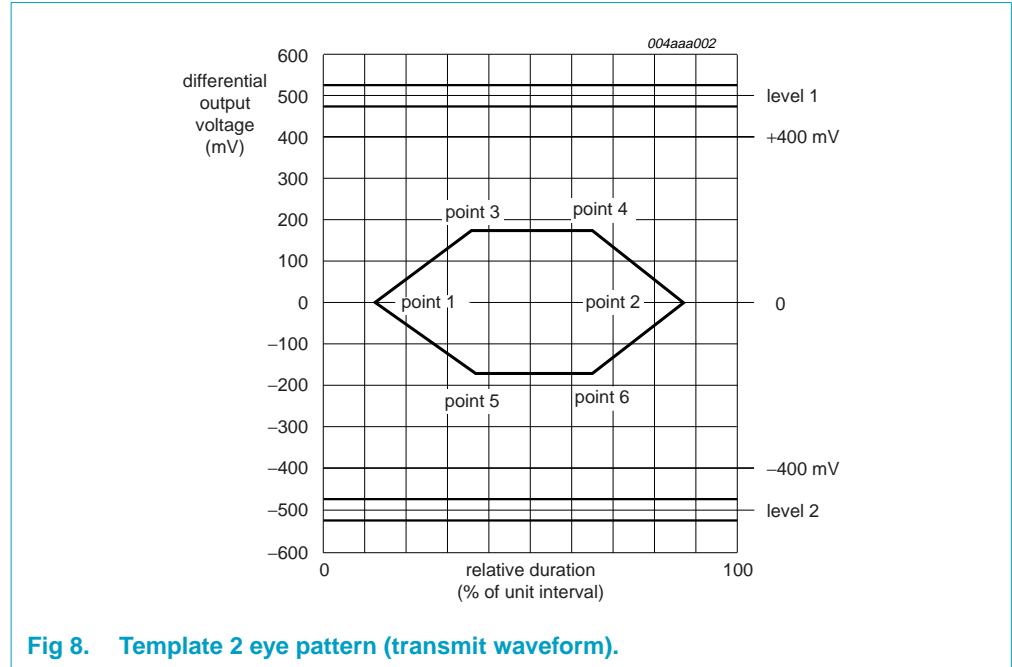

Fig 8. Template 2 eye pattern (transmit waveform).

Table 78: Template 2 eye pattern definition

Name	Differential voltage on DP, DM (mV)	Relative duration (% of unit interval)
Level 1	+525 [1]	n.a.
	+475 [2]	
Level 2	-525 [1]	n.a.
	-475 [2]	
Point 1	0	12.5
Point 2	0	87.5
Point 3	+175	35
Point 4	+175	65
Point 5	-175	35
Point 6	-175	65

[1] In the unit interval following a transition.

[2] In all other cases.



12.1.3 Template 3 (receive waveform; receiver sensitivity with captive cable)

The eye pattern defined in Figure 9 defines the receiver sensitivity requirements for a device with a captive cable (signal applied at test point TP2). The corresponding signal levels and timings are given in Table 79. Timings are given as a percentage of the unit interval (UI), which represents the nominal bit duration  $T_{PERIOD}$  for a 480 Mbit/s transmission rate.

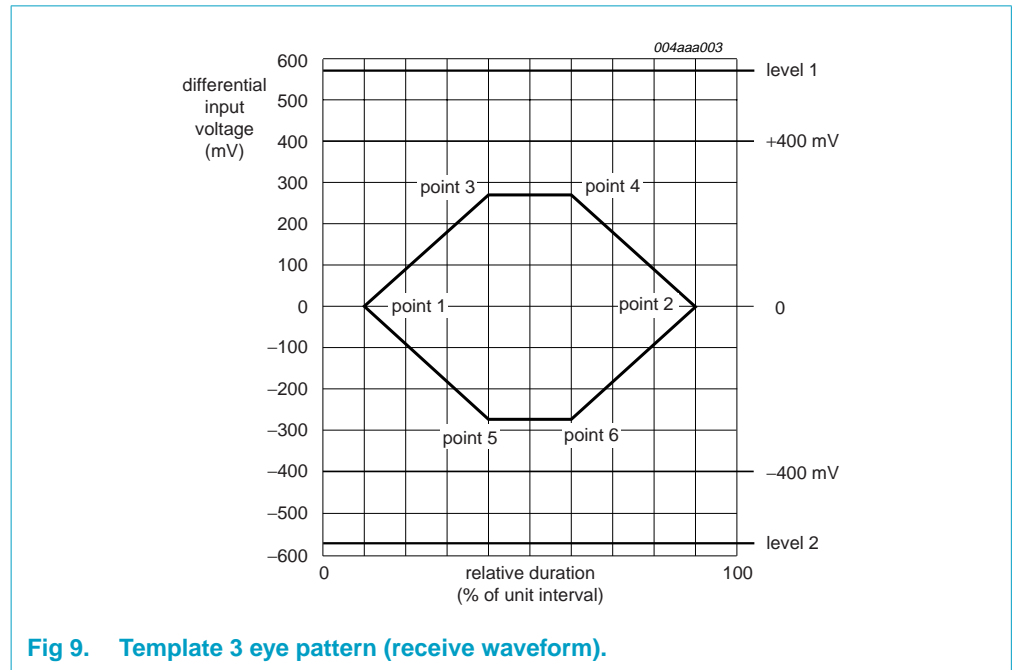

Fig 9. Template 3 eye pattern (receive waveform).

Table 79: Template 3 eye pattern definition

Name	Differential voltage on DP, DM (mV)	Relative duration (% of unit interval)
Level 1	+575	n.a.
Level 2	-575	n.a.
Point 1	0	10
Point 2	0	90
Point 3	+275	40
Point 4	+275	60
Point 5	-275	40
Point 6	-275	60

12.1.4 Template 4 (receive waveform; receiver sensitivity without captive cable)

The eye pattern defined in Figure 10 defines the receiver sensitivity requirements for a hub (signal applied at test point TP2) or a device without a captive cable (signal applied at test point TP3). The corresponding signal levels and timings are given in Table 80. Timings are given as a percentage of the unit interval (UI), which represents the nominal bit duration  $T_{PERIOD}$  for a 480 Mbit/s transmission rate.

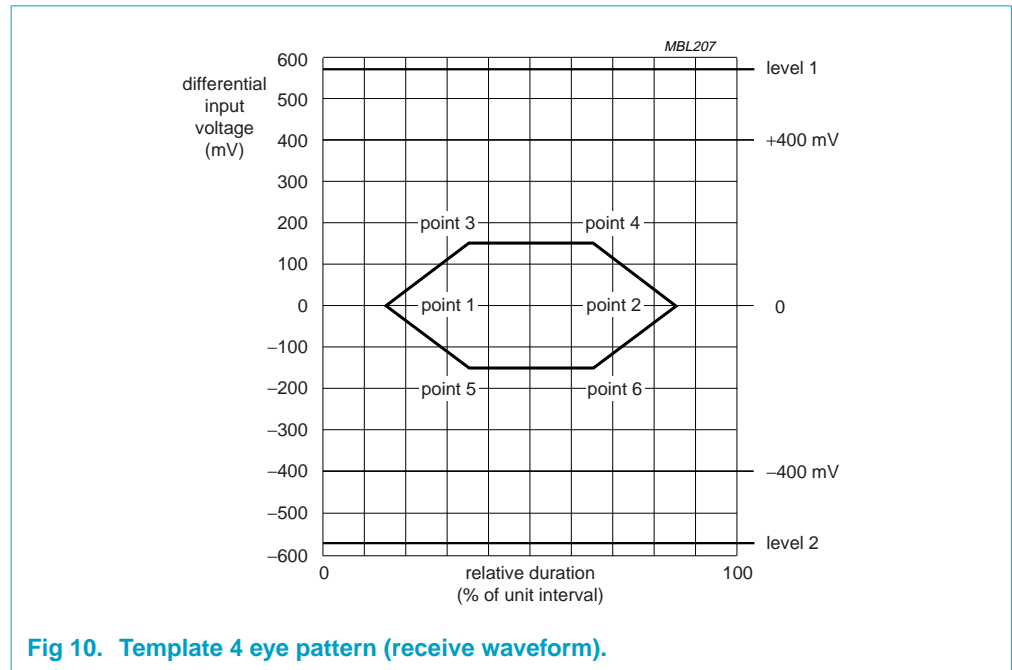

Fig 10. Template 4 eye pattern (receive waveform).

Table 80: Template 4 eye pattern definition

Name	Differential voltage on DP, DM (mV)	Relative duration (% of unit interval)
Level 1	+575	n.a.
Level 2	-575	n.a.
Point 1	0	15
Point 2	0	85
Point 3	+150	35
Point 4	+150	65
Point 5	-150	35
Point 6	-150	65

## 12.2 Timing symbols

Table 81: Legend for timing characteristics

Symbol	Description
<b>Time symbols</b>	
t	time
T	cycle time (periodic signal)
<b>Signal names</b>	
A	address; DMA acknowledge (DACK)
C	clock; command
D	data input; data
E	chip enable
G	output enable
I	instruction (program memory content); input (general)
L	address latch enable (ALE)
P	program store enable ( $\overline{\text{PSEN}}$ , active LOW); propagation delay
Q	data output
R	read signal ( $\overline{\text{RD}}$ , active LOW); read (action); DMA request (DREQ)
S	chip select
W	write signal ( $\overline{\text{WR}}$ , active LOW); write (action); pulse width
U	undefined
Y	output (general)
<b>Logic levels</b>	
H	logic HIGH
L	logic LOW
P	stop, not active (OFF)
S	start, active (ON)
V	valid logic level
X	invalid logic level
Z	high-impedance (floating, three-state)

## 12.3 Parallel I/O timing

### 12.3.1 Generic Processor mode (BUS\_CONF = 1)

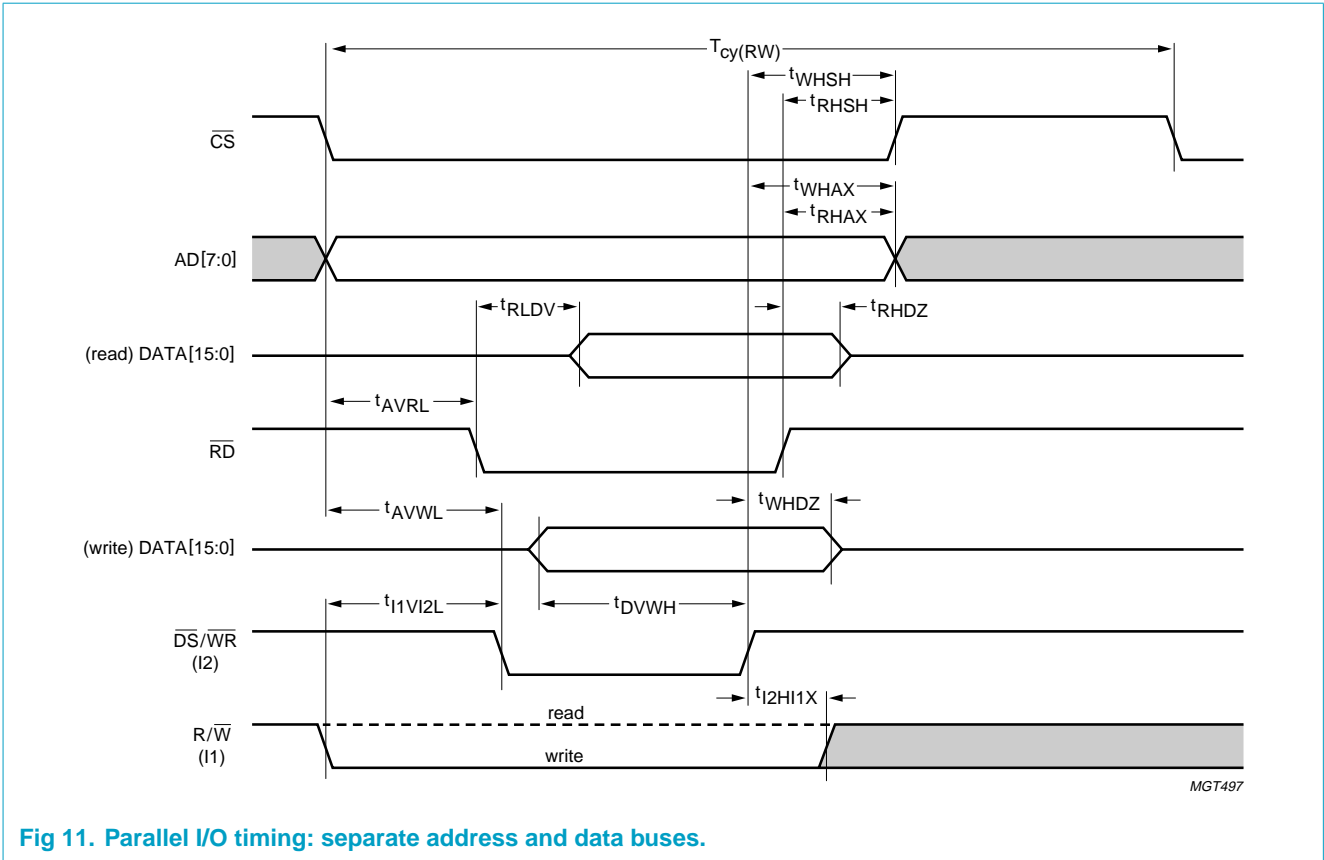

MGT497

Fig 11. Parallel I/O timing: separate address and data buses.

Table 82: Parallel I/O timing parameters: separate address and data buses

Symbol	Parameter	Min	Max	Unit
<b>Reading</b>				
$t_{AVRL}$	address set-up time before $\overline{RD}$ LOW	0	-	ns
$t_{RHAX}$	address hold time after $\overline{RD}$ HIGH	0	-	ns
$t_{RLDV}$	$\overline{RD}$ LOW to data valid delay	-	35	ns
$t_{RHDZ}$	$\overline{RD}$ HIGH to data outputs three-state delay	0	20	ns
$t_{RHS}$	$\overline{RD}$ HIGH to $\overline{CS}$ HIGH delay	0	-	ns
<b>Writing</b>				
$t_{AVWL}$	address set-up time before $\overline{WR}$ LOW	0	-	ns
$t_{WHAX}$	address hold time after $\overline{WR}$ HIGH	0	-	ns
$t_{DVWH}$	data set-up time before $\overline{WR}$ HIGH	25	-	ns
$t_{WHDZ}$	data hold time after $\overline{WR}$ HIGH	0	-	ns
$t_{WHS}$	$\overline{WR}$ HIGH to $\overline{CS}$ HIGH delay	0	-	ns

Table 82: Parallel I/O timing parameters: separate address and data buses...continued

Symbol	Parameter	Min	Max	Unit
<b>General</b>				
$T_{cy(RW)}$	read/write cycle time	60	-	ns
$t_{11VI2L}$	R/ $\bar{W}$ set-up time before $\overline{DS}$ LOW	5	-	ns
$t_{I2HI1X}$	R/ $\bar{W}$ hold time after $\overline{DS}$ HIGH	5	-	ns

12.3.2 Split Bus mode (BUS\_CONF = 0)

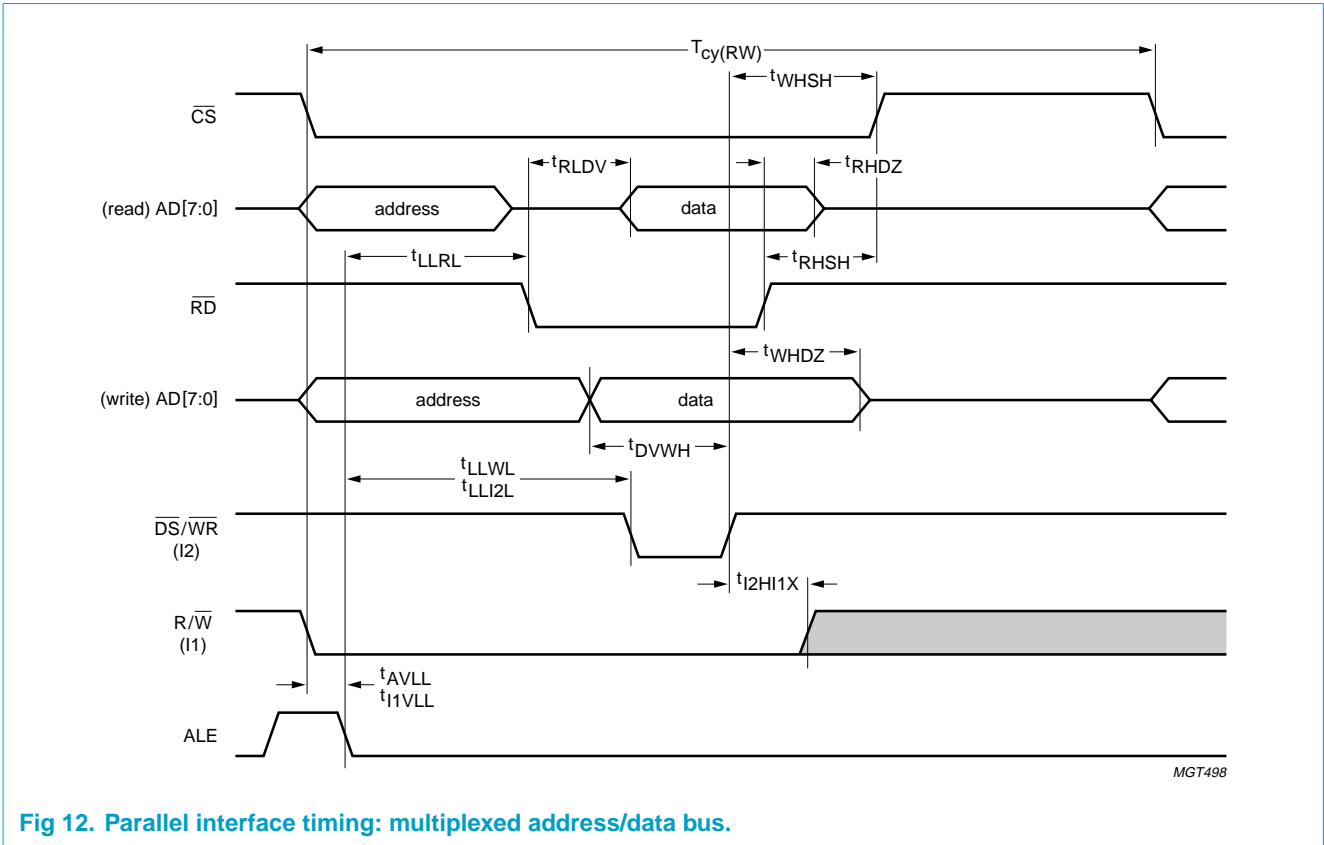

MGT498

Fig 12. Parallel interface timing: multiplexed address/data bus.

Table 83: Parallel I/O timing parameters: multiplexed address/data bus

Symbol	Parameter	Min	Max	Unit
<b>Reading</b>				
$t_{RLDV}$	$\overline{RD}$ LOW to data valid delay	-	35	ns
$t_{RHDZ}$	$\overline{RD}$ HIGH to data outputs three-state delay	0	20	ns
$t_{RHSH}$	$\overline{RD}$ HIGH to $\overline{CS}$ HIGH delay	0	-	ns
$t_{LLRL}$	ALE LOW set-up time before $\overline{RD}$ LOW	0	-	ns
<b>Writing</b>				
$t_{DVWH}$	data set-up time before $\overline{WR}$ HIGH	25	-	ns
$t_{LLWL}$	ALE LOW to $\overline{WR}$ LOW delay	5	-	ns
$t_{WHDZ}$	data hold time after $\overline{WR}$ HIGH	0	-	ns
$t_{WHS}$	$\overline{WR}$ HIGH to $\overline{CS}$ HIGH delay	0	-	ns

Table 83: Parallel I/O timing parameters: multiplexed address/data bus...continued

Symbol	Parameter	Min	Max	Unit
<b>General</b>				
$T_{cy(RW)}$	read/write cycle time	60	-	ns
$t_{AVLL}$	address set-up time before ALE LOW	3	-	ns
$t_{I1VLL}$	R/W set-up time before ALE LOW	3	-	ns
$t_{LLI2L}$	ALE LOW to $\overline{DS}$ LOW delay	5	-	ns
$t_{I2HI1X}$	R/W hold time after $\overline{DS}$ HIGH	5	-	ns

## 12.4 DMA timing

### 12.4.1 PIO mode

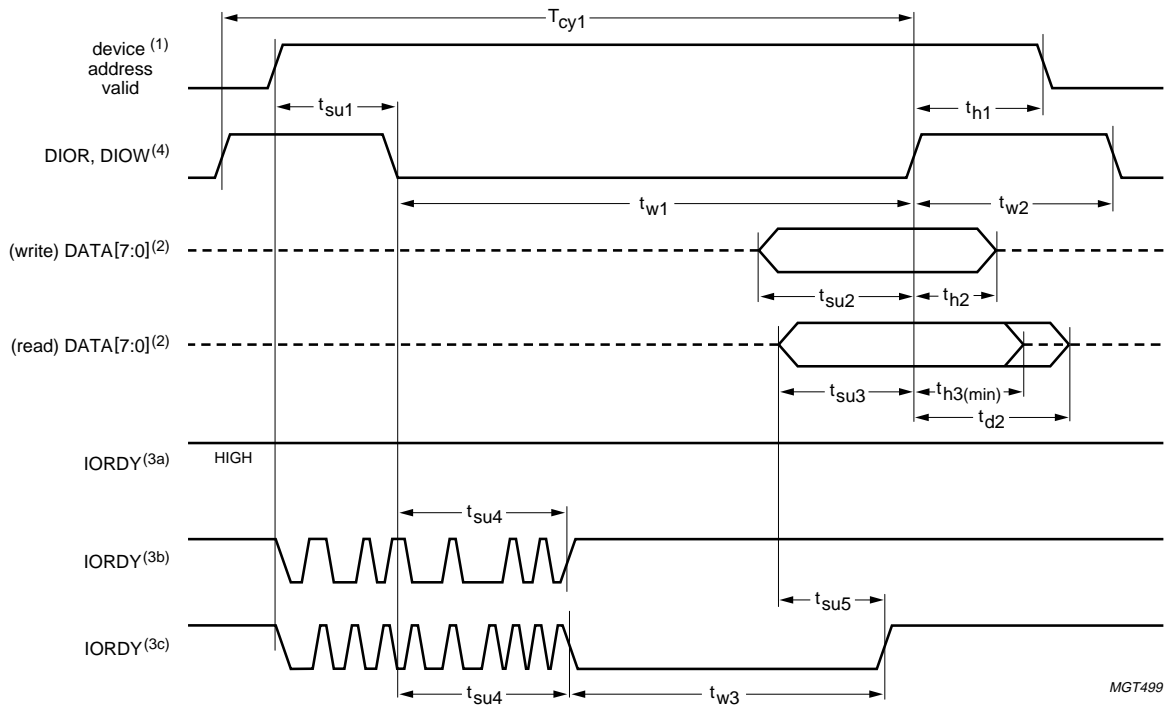

- (1) The device address consists of signals  $\overline{CS1}$ ,  $\overline{CS0}$ , DA2, DA1 and DA0.
- (2) The data bus width depends on the PIO access command used. Task File register access uses 8 bits (DATA[7:0]), except for Task File register 1F0 which uses 16 bits (DATA[15:0]). DMA commands 04H and 05H also use a 16-bit data bus.
- (3) The device can negate IORDY to extend the PIO cycle with wait states. The host determines whether or not to extend the current cycle after  $t_{su4}$  following the assertion of DIOR or DIOW. The following three cases are distinguished:
  - a) Device keeps IORDY released (high-impedance): no wait state is generated.
  - b) Device negates IORDY during  $t_{su4}$ , but re-asserts IORDY before  $t_{su4}$  expires: no wait state is generated.
  - c) Device negates IORDY during  $t_{su4}$  and keeps IORDY negated for at least 5 ns after  $t_{su4}$  expires: a wait state is generated. The cycle is completed as soon as IORDY is re-asserted. For extended read cycles (DIOR asserted), the read data on lines DATA<sub>n</sub> must be valid at  $t_{d1}$  before IORDY is asserted.
- (4) DIOR and DIOW have a programmable polarity: shown here as active LOW signals.

Fig 13. PIO mode timing.

Table 84: PIO mode timing parameters

Symbol	Parameter	Mode 0	Mode 1	Mode 2	Mode 3	Mode 4	Unit
$T_{cy1(min)}$	read/write cycle time (minimum)	[1] 600	383	240	180	120	ns
$t_{su1(min)}$	address to DIOR/DIOW on set-up time (minimum)	70	50	30	30	25	ns
$t_{w1(min)}$	DIOR/DIOW pulse width (minimum)	[1] 165	125	100	80	70	ns
$t_{w2(min)}$	DIOR/DIOW recovery time (minimum)	[1] -	-	-	70	25	ns
$t_{su2(min)}$	data set-up time before DIOW off (minimum)	60	45	30	30	20	ns
$t_{h2(min)}$	data hold time after DIOW off (minimum)	30	20	15	10	10	ns
$t_{su3(min)}$	data set-up time before DIOR on (minimum)	50	35	20	20	20	ns
$t_{h3(min.)}$	data hold time after DIOR off (minimum)	5	5	5	5	5	ns
$t_{d2(max)}$	data to three-state delay after DIOR off (minimum)	[2] 30	30	30	30	30	ns
$t_{h1(min)}$	address hold time after DIOR/DIOW off (minimum)	20	15	10	10	10	ns
$t_{su4(min)}$	IORDY after DIOR/DIOW on set-up time (minimum)	[3] 35	35	35	35	35	ns
$t_{su5(min)}$	read data to IORDY HIGH set-up time (minimum)	[3] 0	0	0	0	0	ns
$t_{w3(max)}$	IORDY LOW pulse width (maximum)	1250	1250	1250	1250	1250	ns

[1]  $T_{cy1}$  is the total cycle time, consisting of the command active time  $t_{w1}$  and is the command recovery (= inactive) time  $t_{w2}$ :  $T_{cy1} = t_{w1} + t_{w2}$ . The minimum timing requirements for  $T_{cy1}$ ,  $t_{w1}$  and  $t_{w2}$  must all be met. Since  $T_{cy1(min)}$  is greater than the sum of  $t_{w1(min)}$  and  $t_{w2(min)}$ , a host implementation must lengthen  $t_{w1}$  and/or  $t_{w2}$  to ensure that  $T_{cy1}$  is equal to or greater than the value reported in the IDENTIFY DEVICE data. A device implementation shall support any legal host implementation.

[2]  $t_{d2}$  specifies the time after DIOR is negated, when the data bus is no longer driven by the device (three-state).

[3] If IORDY is LOW at  $t_{su4}$ , the host waits until IORDY is made HIGH before the PIO cycle is completed. In that case,  $t_{su5}$  must be met for reading ( $t_{su3}$  does not apply). When IORDY is HIGH at  $t_{su4}$ ,  $t_{su3}$  must be met for reading ( $t_{su5}$  does not apply).

12.4.2 GDMA slave mode

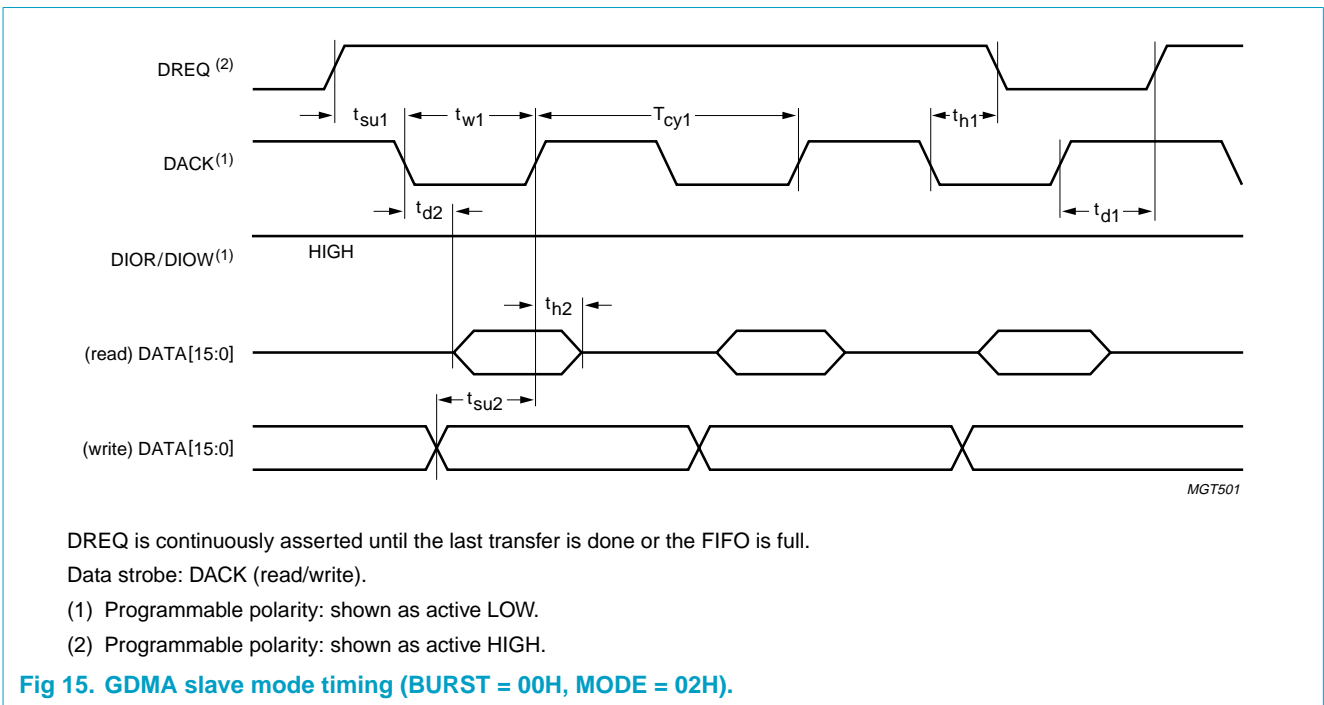
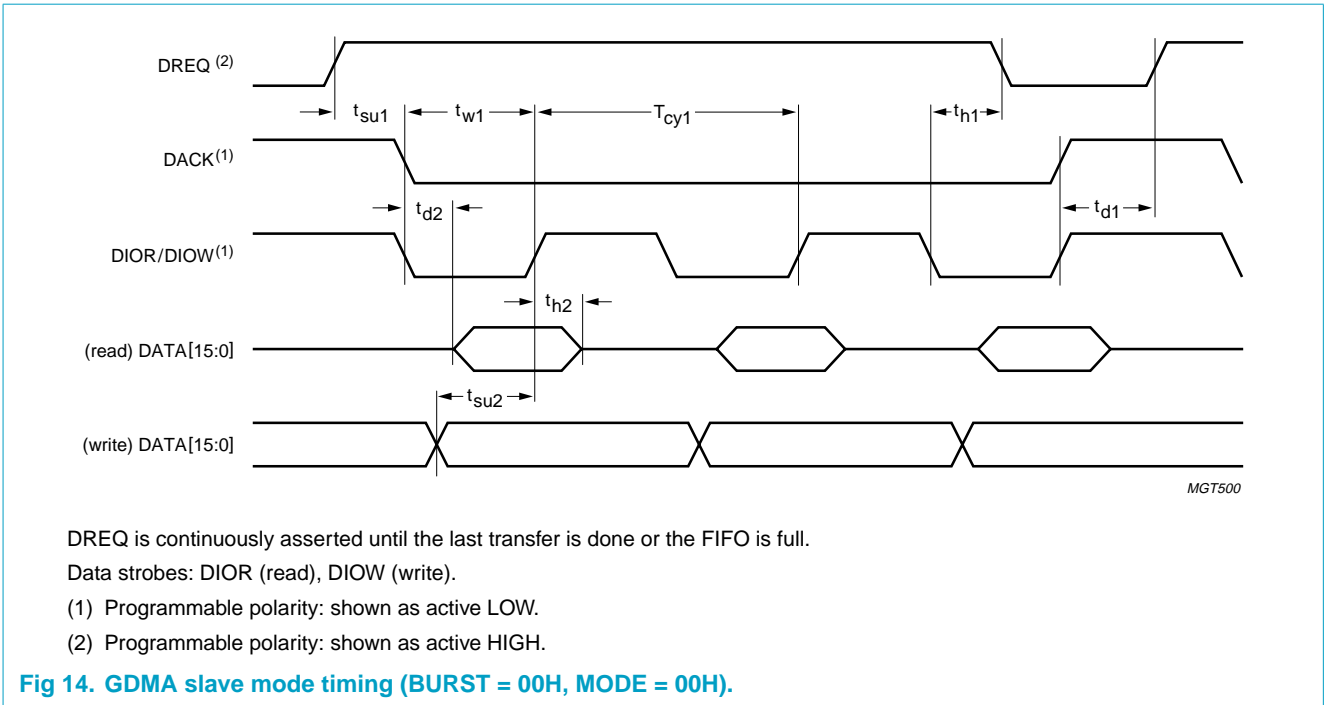



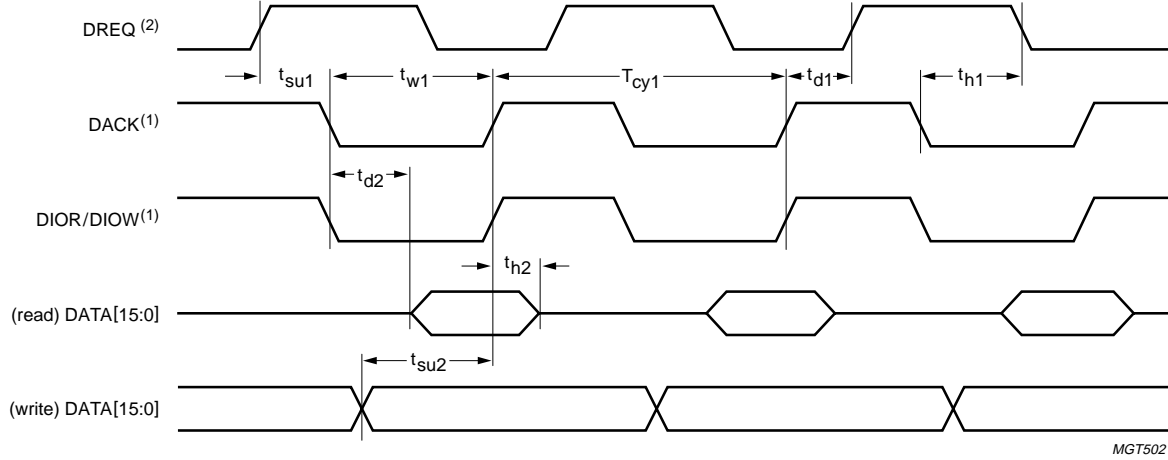

DREQ is asserted for every transfer.  
 Data strobes: DIOR (read), DIOW (write).  
 (1) Programmable polarity: shown as active LOW.  
 (2) Programmable polarity: shown as active HIGH.

**Fig 16. GDMA slave mode timing (BURST = 01H, MODE = 00H).**

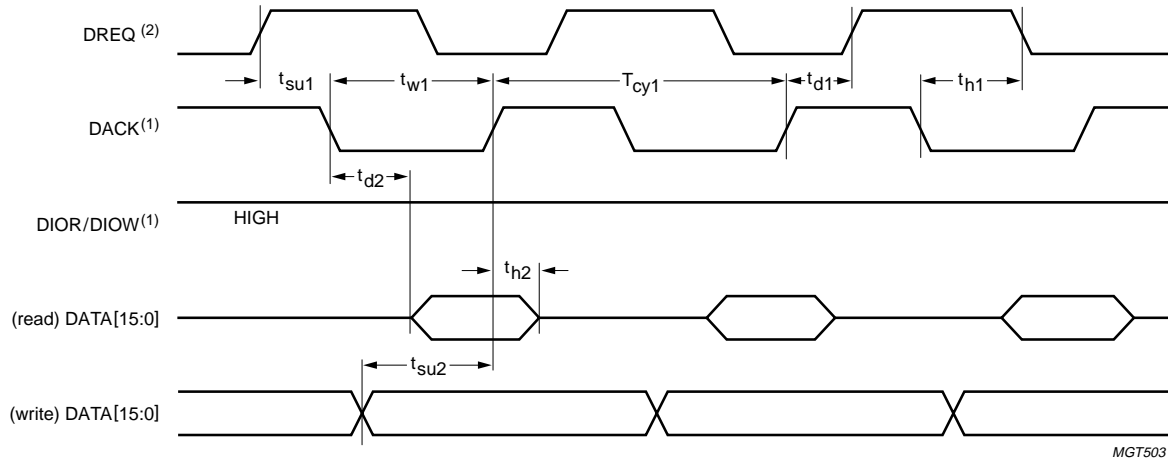

DREQ is asserted for every transfer.  
 Data strobe: DACK (read/write).  
 (1) Programmable polarity: shown as active LOW.  
 (2) Programmable polarity: shown as active HIGH.

**Fig 17. GDMA slave mode timing (BURST = 01H, MODE = 02H).**

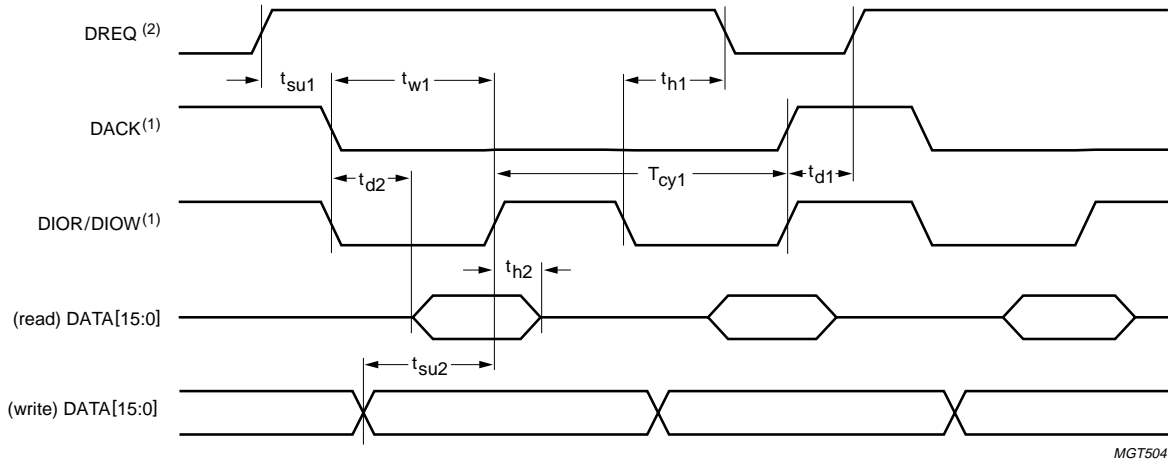

DREQ is asserted once per N transfers (N is determined by the BURST value). Example shown here: N = 2.

Data strobes: DIOR (read), DIOW (write).

- (1) Programmable polarity: shown as active LOW.
- (2) Programmable polarity: shown as active HIGH.

**Fig 18. GDMA slave mode timing (BURST > 01H, MODE = 00H).**

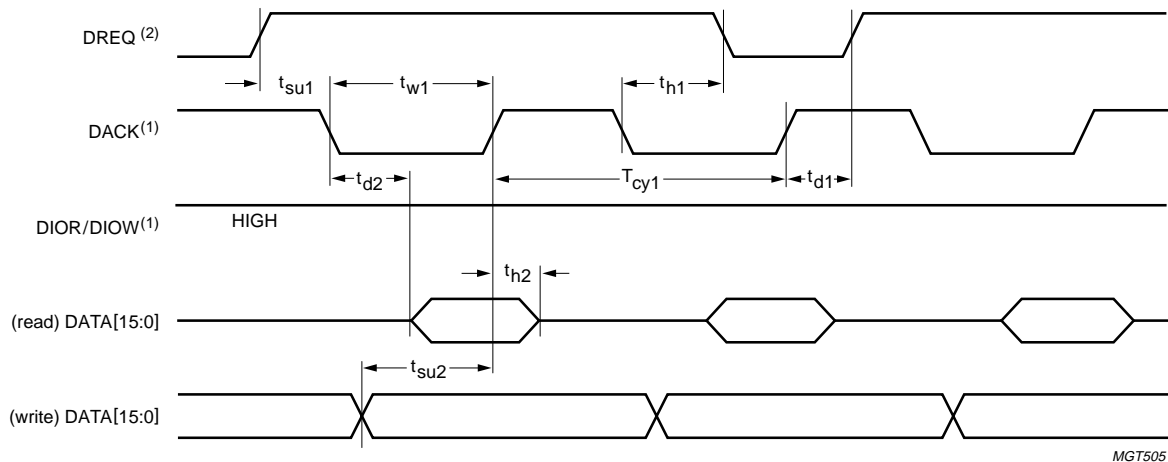

DREQ is asserted once per N transfers (N is determined by the BURST value). Example shown here: N = 2.

Data strobe: DACK (read/write).

- (1) Programmable polarity: shown as active LOW.
- (2) Programmable polarity: shown as active HIGH.

**Fig 19. GDMA slave mode timing (BURST > 01H, MODE = 02H).**

Table 85: GMDA slave mode timing parameters

Symbol	Parameter	Min	Max	Unit
$T_{cy1}$	read/write cycle time	66.67	-	ns
$t_{su1}$	DREQ set-up time before first DACK on	0	-	ns
$t_{d1}$	DREQ on delay after last strobe off	33.33	-	ns
$t_{h1}$	DREQ hold time after last strobe on	0	33.33	ns
$t_{w1}$	DIOR/DIOW pulse width	33.33	-	ns
$t_{d2}$	read data valid delay after strobe on	-	10	ns
$t_{h2}$	read data hold time after strobe off	5	-	ns
$t_{su2}$	write data set-up time before strobe off	10	-	ns

12.4.3 MDMA mode

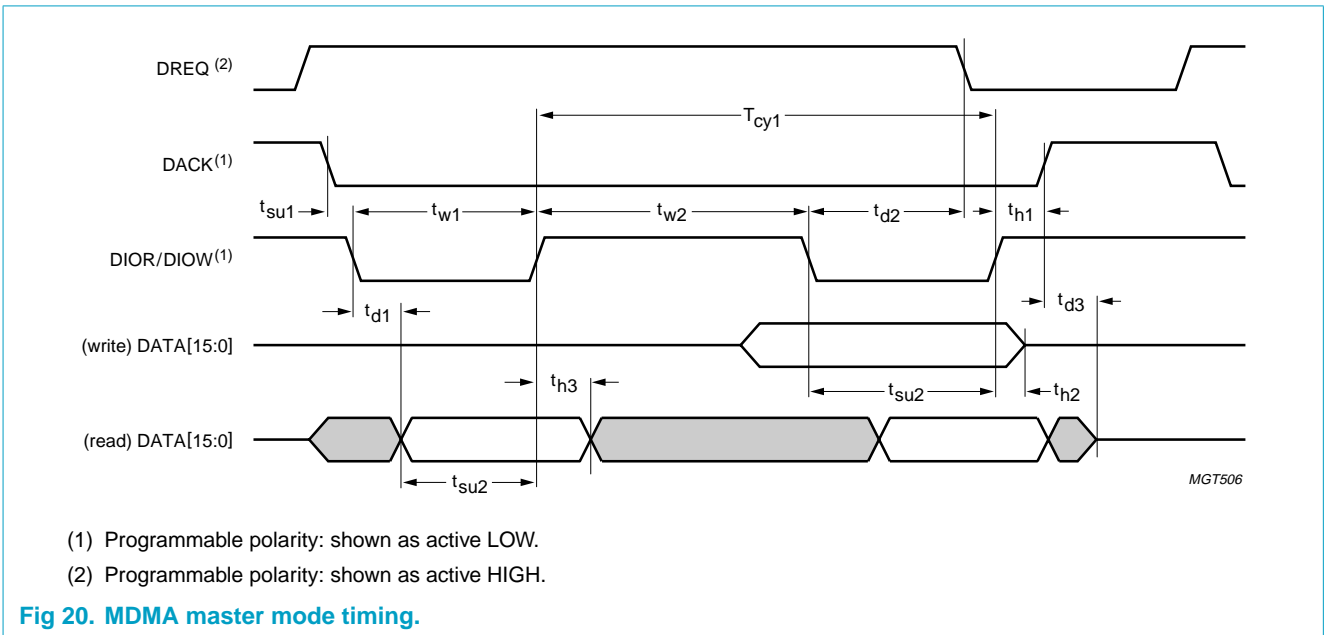

Table 86: MDMA mode timing parameters

Symbol	Parameter	Mode 0	Mode 1	Mode 2	Unit
$T_{cy1(min)}$	read/write cycle time (minimum) [1]	480	150	120	ns
$t_{w1(min)}$	DIOR/DIOW pulse width (minimum) [1]	215	80	70	ns
$t_{d1(max)}$	data valid delay after DIOR on (maximum)	150	60	50	ns
$t_{h3(min)}$	data hold time after DIOR off (minimum)	5	5	5	ns
$t_{su2(min)}$	data set-up time before DIOR/DIOW off (minimum)	100	30	20	ns
$t_{h2(min)}$	data hold time after DIOW off (minimum)	20	15	10	ns
$t_{su1(min)}$	DACK set-up time before DIOR/DIOW on (minimum)	0	0	0	ns
$t_{h1(min)}$	DACK hold time after DIOR/DIOW off (minimum)	20	5	5	ns

Table 86: MDMA mode timing parameters...continued

Symbol	Parameter	Mode 0	Mode 1	Mode 2	Unit
$t_{w2(\min)}$	DIOR recovery time (minimum) [1]	50	50	25	ns
	DIOW recovery time (minimum) [1]	215	50	25	ns
$t_{d2(\max)}$	DIOR on to DREQ off delay (maximum)	120	40	35	ns
	DIOW on to DREQ off delay (maximum)	40	40	35	ns
$t_{d3(\max)}$	DACK off to data lines three-state delay (maximum)	20	25	25	ns

[1]  $T_{cy1}$  is the total cycle time, consisting of the command active time  $t_{w1}$  and is the command recovery (= inactive) time  $t_{w2}$ :  $T_{cy1} = t_{w1} + t_{w2}$ . The minimum timing requirements for  $T_{cy1}$ ,  $t_{w1}$  and  $t_{w2}$  must all be met. Since  $T_{cy1(\min)}$  is greater than the sum of  $t_{w1(\min)}$  and  $t_{w2(\min)}$ , a host implementation must lengthen  $t_{w1}$  and/or  $t_{w2}$  to ensure that  $T_{cy1}$  is equal to or greater than the value reported in the IDENTIFY DEVICE data. A device implementation shall support any legal host implementation.

12.4.4 UDMA mode

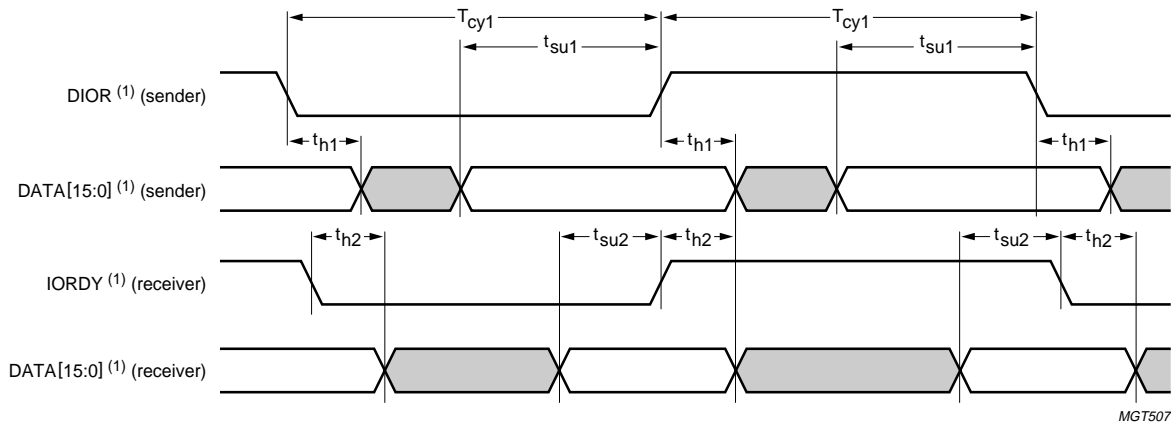

(1) DATA[15:0] and strobe signals at the receiver require some time to stabilize due to the settling time and propagation delay of the cable.

Fig 21. UDMA timing: sustained synchronous burst.

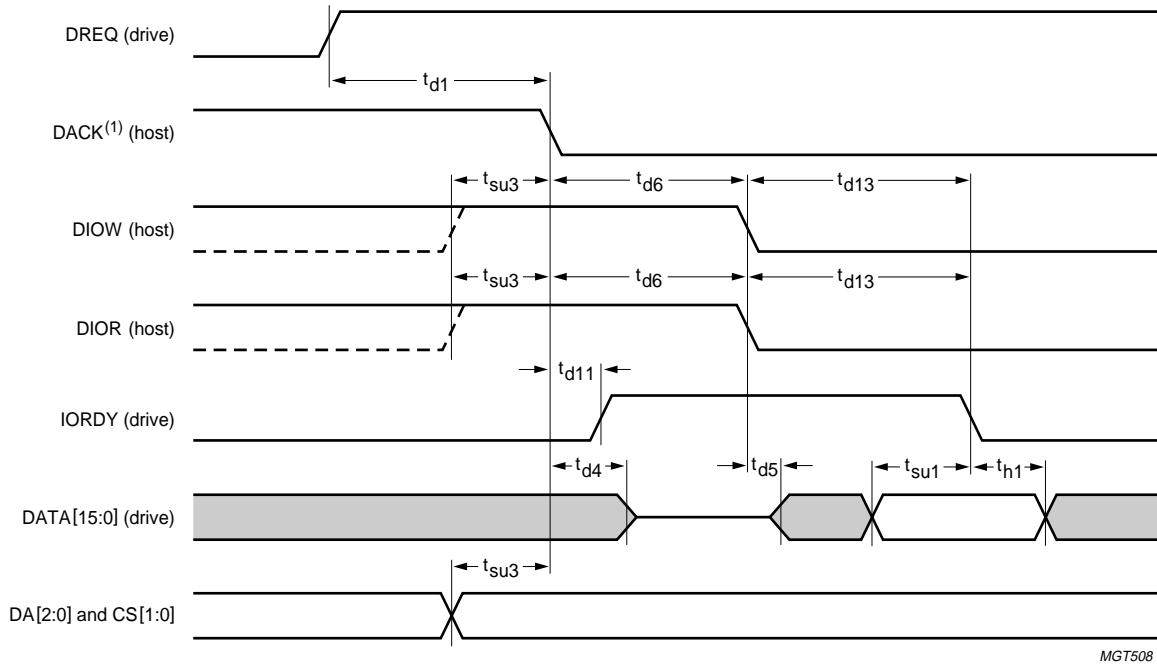

(1) Programmable polarity: shown as active LOW.

**Fig 22. UDMA timing: drive initiating a burst for a read command.**

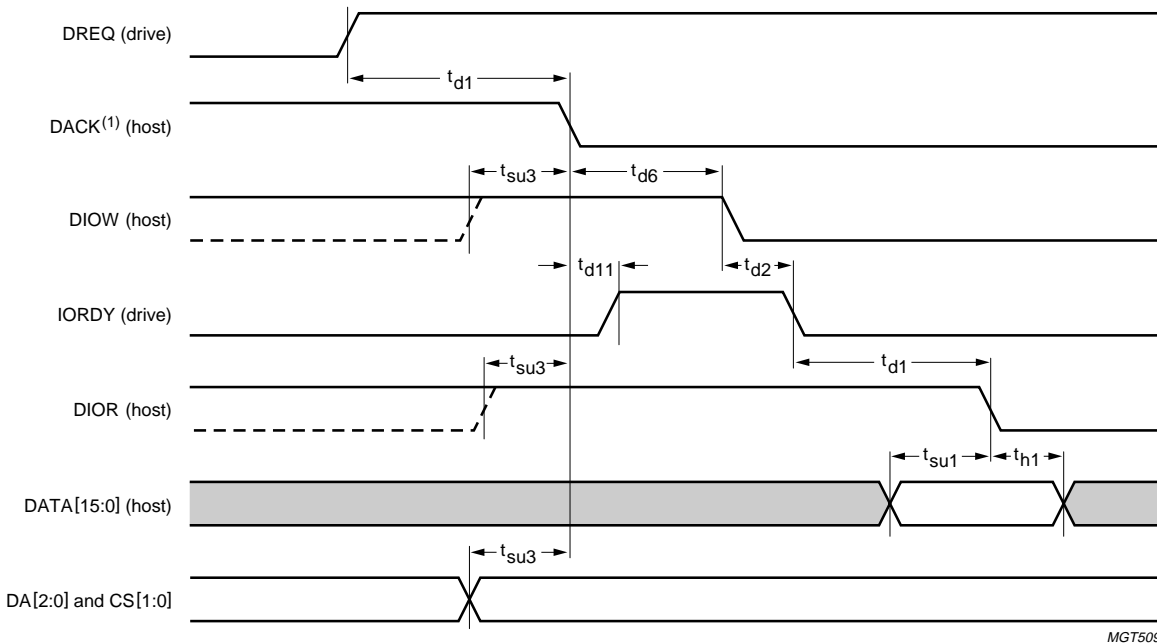

(1) Programmable polarity: shown as active LOW.

**Fig 23. UDMA timing: drive initiating a burst for a write command.**

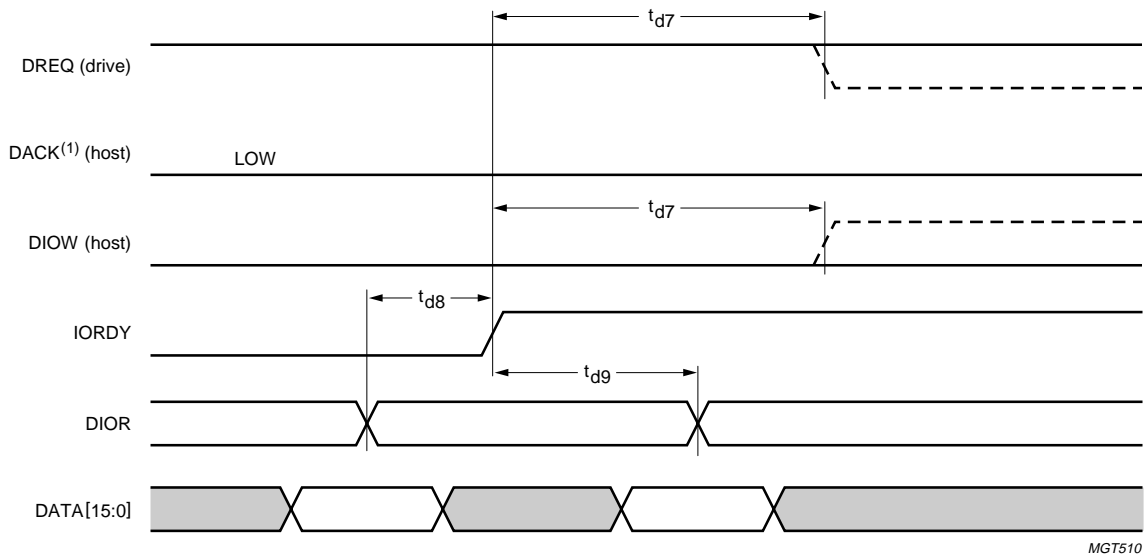

(1) Programmable polarity: shown as active LOW.

**Fig 24. UDMA timing: receiver pausing a burst.**

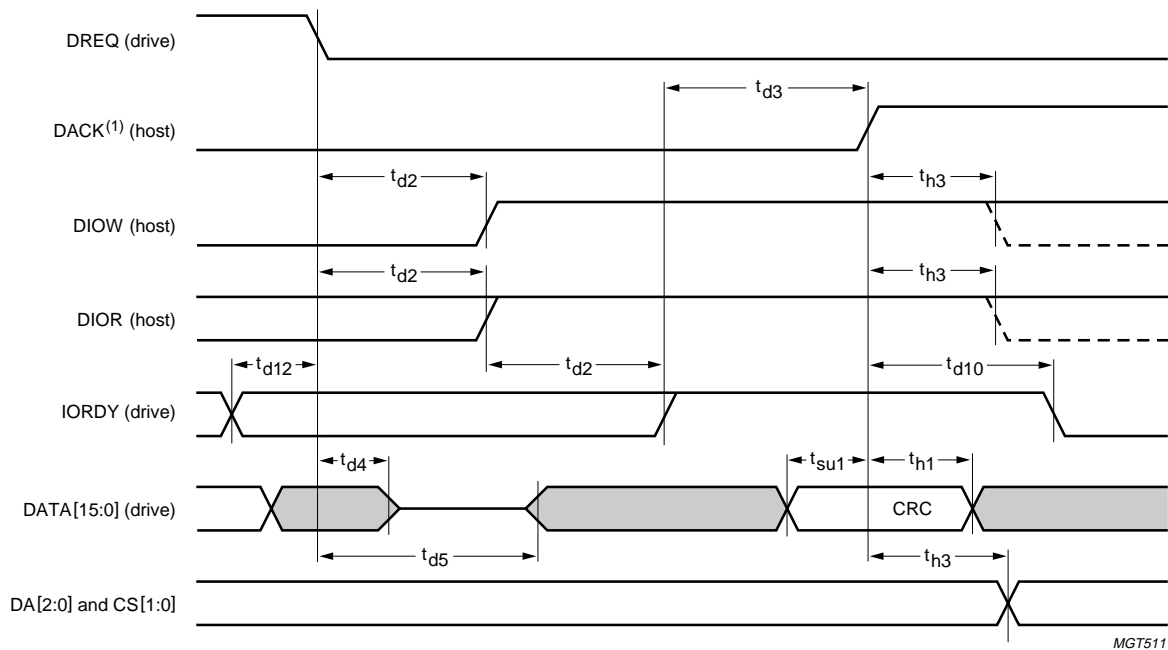

(1) Programmable polarity: shown as active LOW.

**Fig 25. UDMA timing: drive terminating a burst during a read command.**

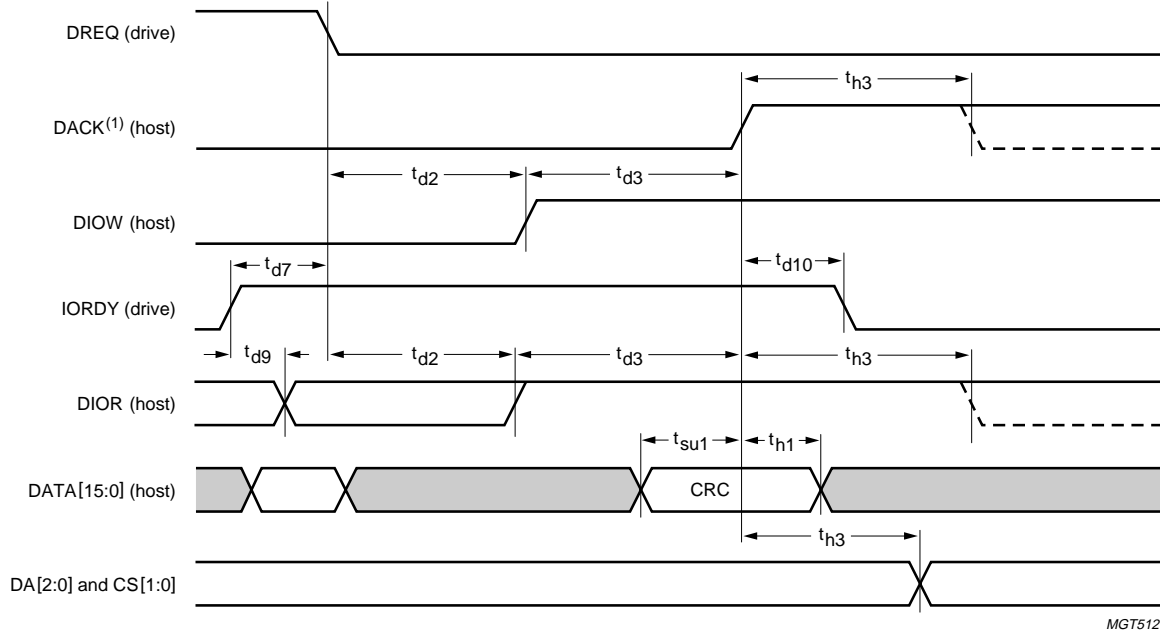

MGT512

(1) Programmable polarity: shown as active LOW.

Fig 26. UDMA timing: drive terminating a burst during a write command.

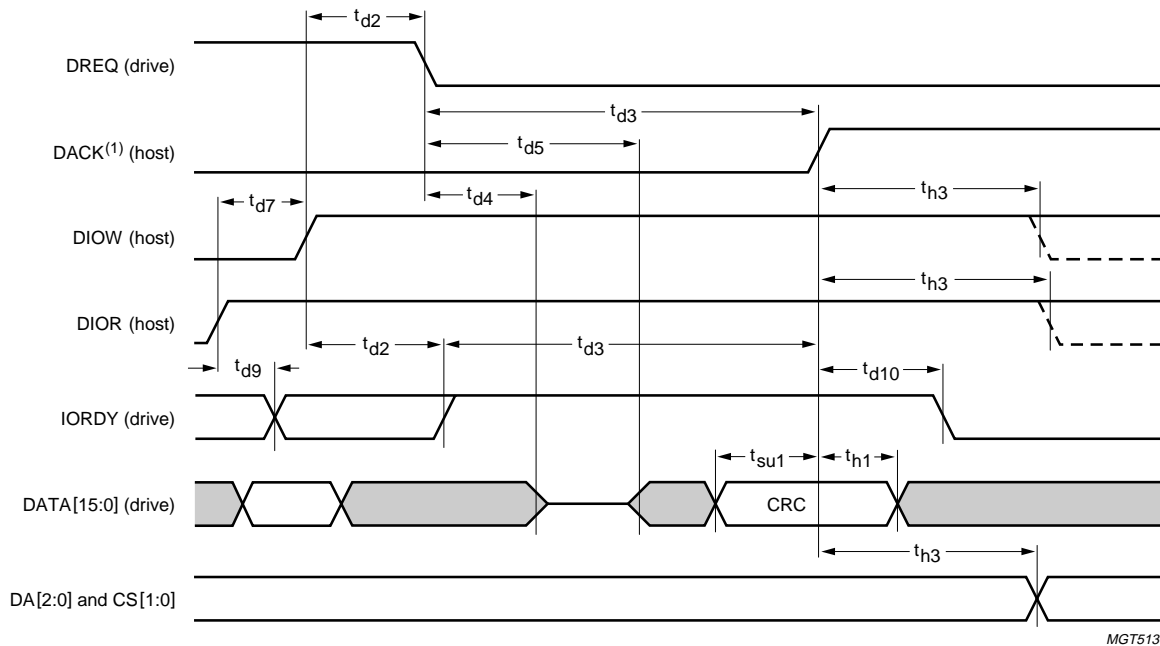

MGT513

(1) Programmable polarity: shown as active LOW.

Fig 27. UDMA timing: host terminating a burst during a read command.

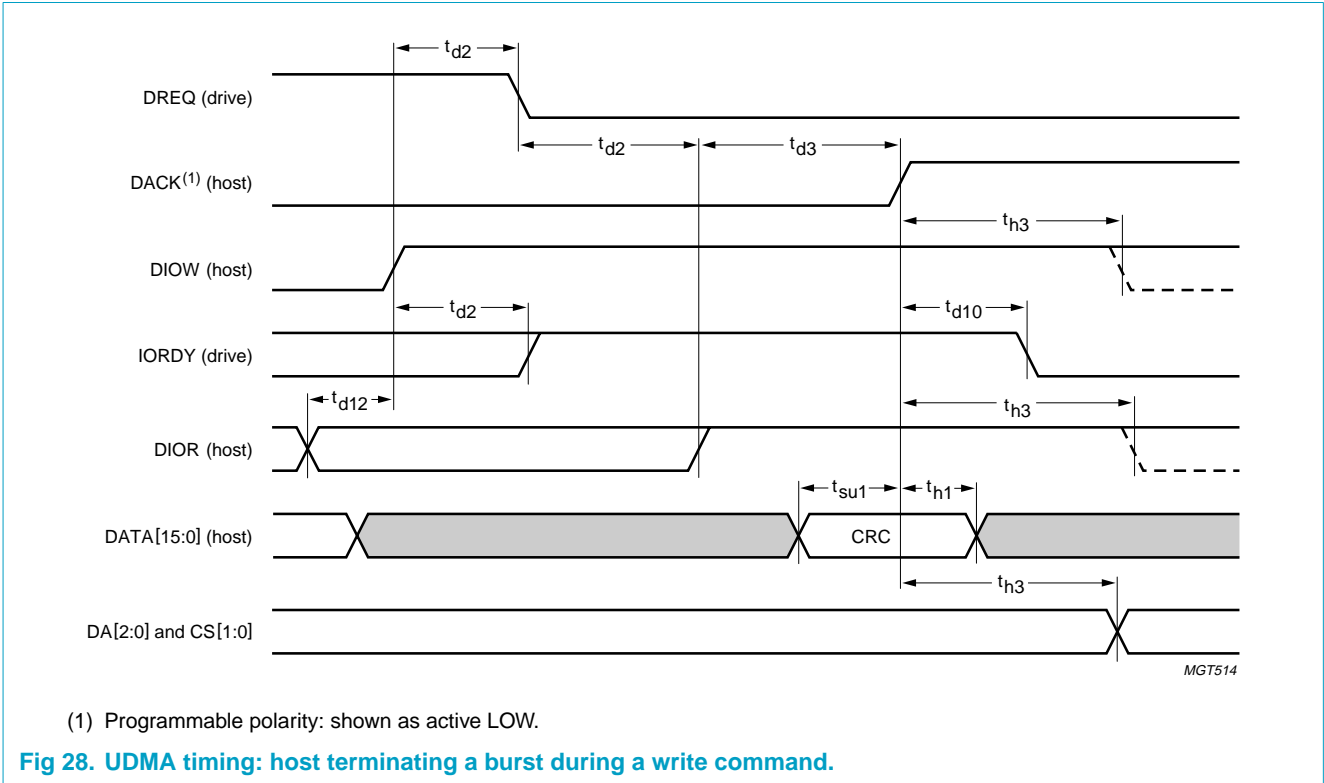

Table 87: UDMA mode timing parameters

Symbol	Parameter	Mode 0		Mode 1		Mode 2		Unit
		Min	Max	Min	Max	Min	Max	
T <sub>cy1</sub>	read/write cycle time (from strobe edge to strobe edge)	114	-	75	-	55	-	ns
t <sub>su2</sub>	data set-up time at receiver	15	-	10	-	7	-	ns
t <sub>h2</sub>	data hold time at receiver	5	-	5	-	5	-	ns
t <sub>su1</sub>	data set-up time at sender	70	-	48	-	34	-	ns
t <sub>h1</sub>	data hold time at sender	6	-	6	-	6	-	ns
t <sub>d1</sub>	unlimited interlock time <sup>[1]</sup>	0	-	0	-	0	-	ns
t <sub>d2</sub>	limited interlock time <sup>[1]</sup>	0	150	0	150	0	150	ns
t <sub>d3</sub>	limited interlock time with minimum <sup>[1]</sup>	20	-	20	-	20	-	ns
t <sub>d4</sub>	data line drivers switch-off delay	-	10	-	10	-	10	ns
t <sub>d5</sub>	data line drivers switch-on delay (host)	20	-	20	-	20	-	ns
	data line drivers switch-on delay (drive)	0	-	0	-	0	-	ns
t <sub>su3</sub>	control signal set-up time before DACK on	20	-	20	-	20	-	ns
t <sub>h3</sub>	control signal hold time after DACK off	20	-	20	-	20	-	ns
t <sub>d6</sub>	DACK on to control signal transition delay	20	70	20	70	20	70	ns
t <sub>d7</sub>	ready to paused delay	160	-	125	-	100	-	ns
t <sub>d8</sub>	strobe to ready delay to ensure a synchronous pause	-	50	-	30	-	20	ns
t <sub>d9</sub>	ready to final strobe edge delay	-	75	-	60	-	50	ns



Table 87: UDMA mode timing parameters...continued

Symbol	Parameter	Mode 0		Mode 1		Mode 2		Unit
		Min	Max	Min	Max	Min	Max	
t <sub>d10</sub>	DACK off to IORDY high-Z delay	-	20	-	20	-	20	ns
t <sub>d11</sub>	DACK on to IORDY HIGH delay	0	-	0	-	0	-	ns
t <sub>d12</sub>	final strobe edge to DREQ off or DIOW on delay	50	-	50	-	50	-	ns
t <sub>d13</sub>	first strobe delay after control signal on	0	230	0	200	0	170	ns

[1] Interlock time is the time allowed between an action by one agent and the following action by the other agent. An agent can be a sender or a receiver. Interlocking actions require a response signal from the other agent before processing can continue.

### 13. Application information

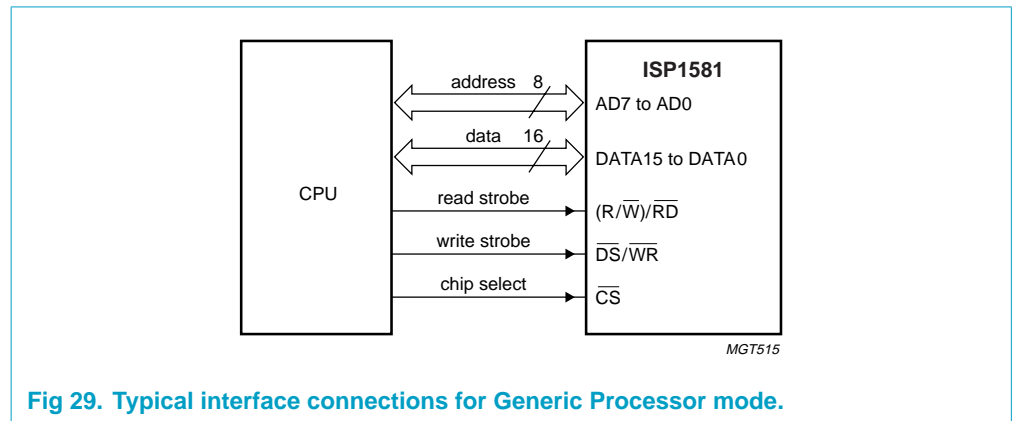

Fig 29. Typical interface connections for Generic Processor mode.

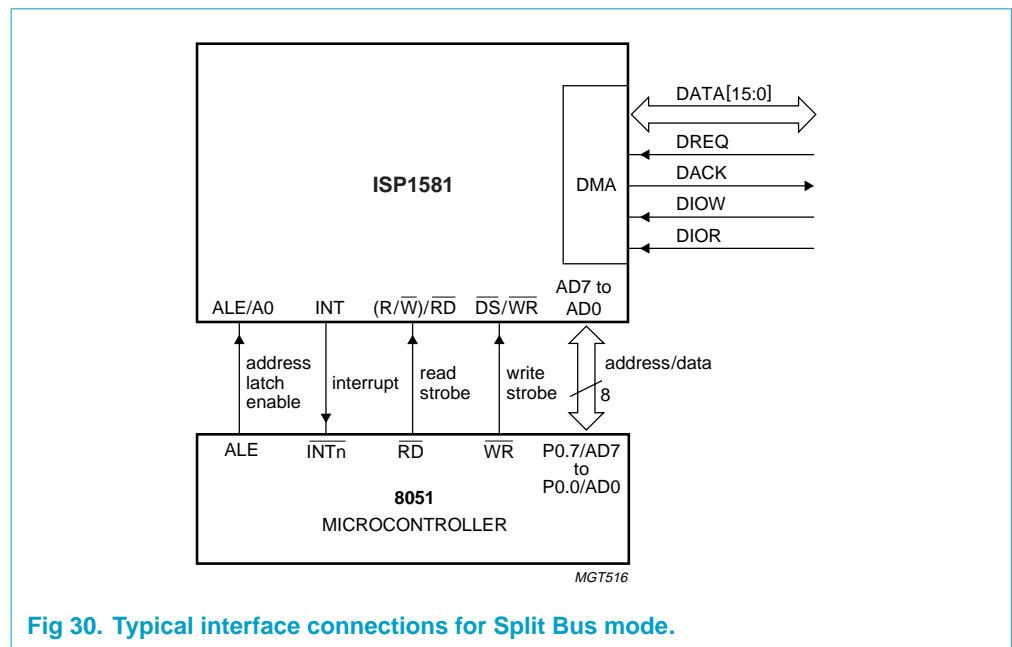
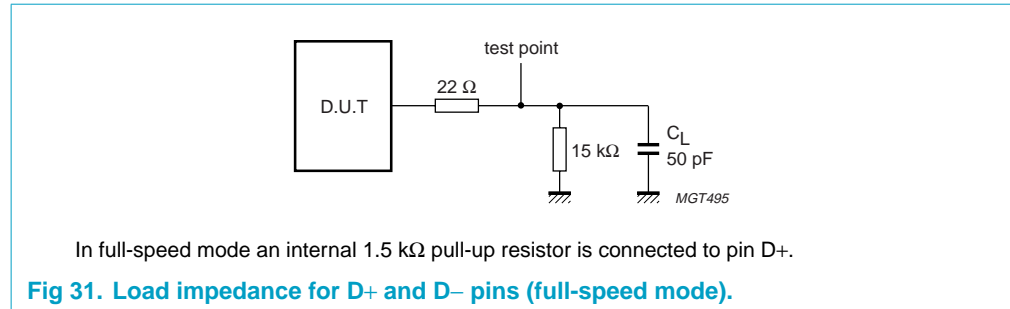

Fig 30. Typical interface connections for Split Bus mode.

## 14. Test information

The dynamic characteristics of the analog I/O ports (D+, D-) as listed in [Table 76](#), were determined using the circuit shown in [Figure 31](#).



15. Package outline

LQFP64: plastic low profile quad flat package; 64 leads; body 10 x 10 x 1.4 mm

SOT314-2

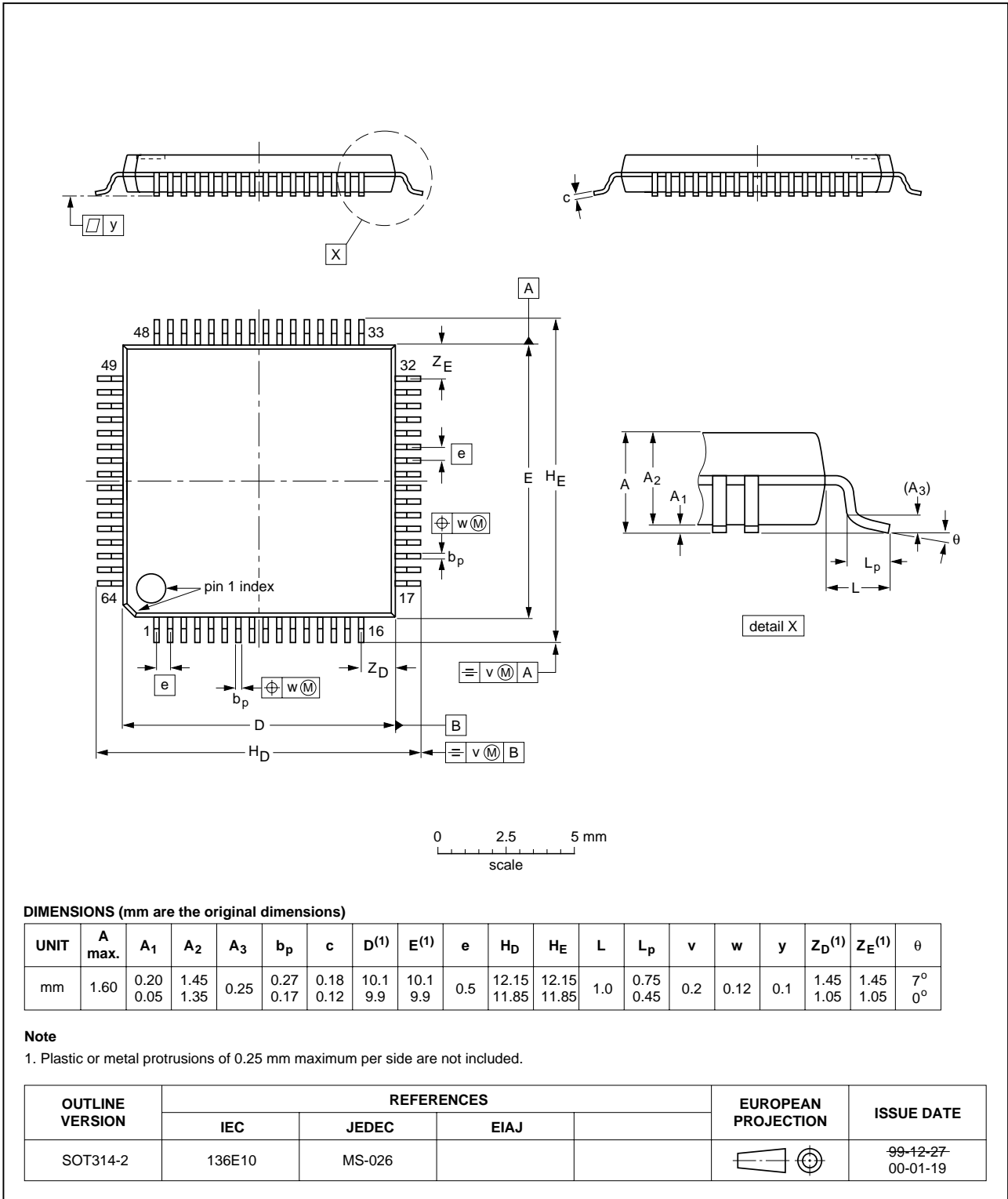

Fig 32. LQFP64 package outline.

## 16. Soldering

### 16.1 Introduction to soldering surface mount packages

This text gives a very brief insight to a complex technology. A more in-depth account of soldering ICs can be found in our *Data Handbook IC26; Integrated Circuit Packages* (document order number 9398 652 90011).

There is no soldering method that is ideal for all surface mount IC packages. Wave soldering can still be used for certain surface mount ICs, but it is not suitable for fine pitch SMDs. In these situations reflow soldering is recommended.

### 16.2 Reflow soldering

Reflow soldering requires solder paste (a suspension of fine solder particles, flux and binding agent) to be applied to the printed-circuit board by screen printing, stencilling or pressure-syringe dispensing before package placement.

Several methods exist for reflowing; for example, convection or convection/infrared heating in a conveyor type oven. Throughput times (preheating, soldering and cooling) vary between 100 and 200 seconds depending on heating method.

Typical reflow peak temperatures range from 215 to 250 °C. The top-surface temperature of the packages should preferably be kept below 220 °C for thick/large packages, and below 235 °C small/thin packages.

### 16.3 Wave soldering

Conventional single wave soldering is not recommended for surface mount devices (SMDs) or printed-circuit boards with a high component density, as solder bridging and non-wetting can present major problems.

To overcome these problems the double-wave soldering method was specifically developed.

If wave soldering is used the following conditions must be observed for optimal results:

- Use a double-wave soldering method comprising a turbulent wave with high upward pressure followed by a smooth laminar wave.
- For packages with leads on two sides and a pitch (e):
  - larger than or equal to 1.27 mm, the footprint longitudinal axis is **preferred** to be parallel to the transport direction of the printed-circuit board;
  - smaller than 1.27 mm, the footprint longitudinal axis **must** be parallel to the transport direction of the printed-circuit board.

The footprint must incorporate solder thieves at the downstream end.

- For packages with leads on four sides, the footprint must be placed at a 45° angle to the transport direction of the printed-circuit board. The footprint must incorporate solder thieves downstream and at the side corners.

During placement and before soldering, the package must be fixed with a droplet of adhesive. The adhesive can be applied by screen printing, pin transfer or syringe dispensing. The package can be soldered after the adhesive is cured.

Typical dwell time is 4 seconds at 250 °C. A mildly-activated flux will eliminate the need for removal of corrosive residues in most applications.

## 16.4 Manual soldering

Fix the component by first soldering two diagonally-opposite end leads. Use a low voltage (24 V or less) soldering iron applied to the flat part of the lead. Contact time must be limited to 10 seconds at up to 300 °C.

When using a dedicated tool, all other leads can be soldered in one operation within 2 to 5 seconds between 270 and 320 °C.

## 16.5 Package related soldering information

**Table 88: Suitability of surface mount IC packages for wave and reflow soldering methods**

Package	Soldering method	
	Wave	Reflow <sup>[1]</sup>
BGA, LFBGA, SQFP, TFBGA	not suitable	suitable
HBCC, HLQFP, HSQFP, HSOP, HTQFP, HTSSOP, SMS	not suitable <sup>[2]</sup>	suitable
PLCC <sup>[3]</sup> , SO, SOJ	suitable	suitable
LQFP, QFP, TQFP	not recommended <sup>[3][4]</sup>	suitable
SSOP, TSSOP, VSO	not recommended <sup>[5]</sup>	suitable

- [1] All surface mount (SMD) packages are moisture sensitive. Depending upon the moisture content, the maximum temperature (with respect to time) and body size of the package, there is a risk that internal or external package cracks may occur due to vaporization of the moisture in them (the so called popcorn effect). For details, refer to the Drypack information in the *Data Handbook IC26; Integrated Circuit Packages; Section: Packing Methods*.
- [2] These packages are not suitable for wave soldering as a solder joint between the printed-circuit board and heatsink (at bottom version) can not be achieved, and as solder may stick to the heatsink (on top version).
- [3] If wave soldering is considered, then the package must be placed at a 45° angle to the solder wave direction. The package footprint must incorporate solder thieves downstream and at the side corners.
- [4] Wave soldering is only suitable for LQFP, QFP and TQFP packages with a pitch (e) equal to or larger than 0.8 mm; it is definitely not suitable for packages with a pitch (e) equal to or smaller than 0.65 mm.
- [5] Wave soldering is only suitable for SSOP and TSSOP packages with a pitch (e) equal to or larger than 0.65 mm; it is definitely not suitable for packages with a pitch (e) equal to or smaller than 0.5 mm.

## 17. Revision history

Table 89: Revision history

Rev	Date	CPCN	Description
02	20001023		<b>Objective specification; second version. Supersedes ISP1581-01 of 4 October 2000 (9397 750 07487).</b> Package replaced by SOT314-2.
01	20001004		<b>Objective specification; initial version. Not published.</b>

## 18. Data sheet status

Datasheet status	Product status	Definition <sup>[1]</sup>
Objective specification	Development	This data sheet contains the design target or goal specifications for product development. Specification may change in any manner without notice.
Preliminary specification	Qualification	This data sheet contains preliminary data, and supplementary data will be published at a later date. Philips Semiconductors reserves the right to make changes at any time without notice in order to improve design and supply the best possible product.
Product specification	Production	This data sheet contains final specifications. Philips Semiconductors reserves the right to make changes at any time without notice in order to improve design and supply the best possible product.

[1] Please consult the most recently issued data sheet before initiating or completing a design.

## 19. Definitions

**Short-form specification** — The data in a short-form specification is extracted from a full data sheet with the same type number and title. For detailed information see the relevant data sheet or data handbook.

**Limiting values definition** — Limiting values given are in accordance with the Absolute Maximum Rating System (IEC 60134). Stress above one or more of the limiting values may cause permanent damage to the device. These are stress ratings only and operation of the device at these or at any other conditions above those given in the Characteristics sections of the specification is not implied. Exposure to limiting values for extended periods may affect device reliability.

**Application information** — Applications that are described herein for any of these products are for illustrative purposes only. Philips Semiconductors make no representation or warranty that such applications will be suitable for the specified use without further testing or modification.

## 20. Disclaimers

**Life support** — These products are not designed for use in life support appliances, devices, or systems where malfunction of these products can reasonably be expected to result in personal injury. Philips Semiconductors customers using or selling these products for use in such applications do so at their own risk and agree to fully indemnify Philips Semiconductors for any damages resulting from such application.

**Right to make changes** — Philips Semiconductors reserves the right to make changes, without notice, in the products, including circuits, standard cells, and/or software, described or contained herein in order to improve design and/or performance. Philips Semiconductors assumes no responsibility or liability for the use of any of these products, conveys no licence or title under any patent, copyright, or mask work right to these products, and makes no representations or warranties that these products are free from patent, copyright, or mask work right infringement, unless otherwise specified.

## 21. Trademarks

**ACPI** — is an open industry specification for PC power management, co-developed by Intel Corp., Microsoft Corp. and Toshiba

**Jaz** — is a registered trademark of Iomega Corp.

**OnNow** — is a trademark of Microsoft Corp.

**SoftConnect** — is a trademark of Royal Philips Electronics

**Zip** — is a registered trademark of Iomega Corp.

## Philips Semiconductors - a worldwide company

**Argentina:** see South America

**Australia:** Tel. +61 2 9704 8141, Fax. +61 2 9704 8139

**Austria:** Tel. +43 160 101, Fax. +43 160 101 1210

**Belarus:** Tel. +375 17 220 0733, Fax. +375 17 220 0773

**Belgium:** see The Netherlands

**Brazil:** see South America

**Bulgaria:** Tel. +359 268 9211, Fax. +359 268 9102

**Canada:** Tel. +1 800 234 7381

**China/Hong Kong:** Tel. +852 2 319 7888, Fax. +852 2 319 7700

**Colombia:** see South America

**Czech Republic:** see Austria

**Denmark:** Tel. +45 3 288 2636, Fax. +45 3 157 0044

**Finland:** Tel. +358 961 5800, Fax. +358 96 158 0920

**France:** Tel. +33 14 099 6161, Fax. +33 14 099 6427

**Germany:** Tel. +49 40 23 5360, Fax. +49 402 353 6300

**Hungary:** see Austria

**India:** Tel. +91 22 493 8541, Fax. +91 22 493 8722

**Indonesia:** see Singapore

**Ireland:** Tel. +353 17 64 0000, Fax. +353 17 64 0200

**Israel:** Tel. +972 36 45 0444, Fax. +972 36 49 1007

**Italy:** Tel. +39 039 203 6838, Fax. +39 039 203 6800

**Japan:** Tel. +81 33 740 5130, Fax. +81 3 3740 5057

**Korea:** Tel. +82 27 09 1412, Fax. +82 27 09 1415

**Malaysia:** Tel. +60 37 50 5214, Fax. +60 37 57 4880

**Mexico:** Tel. +9-5 800 234 7381

**Middle East:** see Italy

**For all other countries apply to:** Philips Semiconductors,  
Marketing Communications,  
Building BE, P.O. Box 218, 5600 MD EINDHOVEN,  
The Netherlands, Fax. +31 40 272 4825

**Netherlands:** Tel. +31 40 278 2785, Fax. +31 40 278 8399

**New Zealand:** Tel. +64 98 49 4160, Fax. +64 98 49 7811

**Norway:** Tel. +47 22 74 8000, Fax. +47 22 74 8341

**Philippines:** Tel. +63 28 16 6380, Fax. +63 28 17 3474

**Poland:** Tel. +48 22 5710 000, Fax. +48 22 5710 001

**Portugal:** see Spain

**Romania:** see Italy

**Russia:** Tel. +7 095 755 6918, Fax. +7 095 755 6919

**Singapore:** Tel. +65 350 2538, Fax. +65 251 6500

**Slovakia:** see Austria

**Slovenia:** see Italy

**South Africa:** Tel. +27 11 471 5401, Fax. +27 11 471 5398

**South America:** Tel. +55 11 821 2333, Fax. +55 11 829 1849

**Spain:** Tel. +34 33 01 6312, Fax. +34 33 01 4107

**Sweden:** Tel. +46 86 32 2000, Fax. +46 86 32 2745

**Switzerland:** Tel. +41 14 88 2686, Fax. +41 14 81 7730

**Taiwan:** Tel. +886 22 134 2451, Fax. +886 22 134 2874

**Thailand:** Tel. +66 23 61 7910, Fax. +66 23 98 3447

**Turkey:** Tel. +90 216 522 1500, Fax. +90 216 522 1813

**Ukraine:** Tel. +380 44 264 2776, Fax. +380 44 268 0461

**United Kingdom:** Tel. +44 208 730 5000, Fax. +44 208 754 8421

**United States:** Tel. +1 800 234 7381

**Uruguay:** see South America

**Vietnam:** see Singapore

**Yugoslavia:** Tel. +381 11 3341 299, Fax. +381 11 3342 553

**Internet:** <http://www.semiconductors.philips.com>

(SCA70)



## Contents

<b>1</b>	<b>General description</b> . . . . .	1	9.4.9	DMA Endpoint register (address: 58H) . . . . .	36
<b>2</b>	<b>Features</b> . . . . .	2	9.5	General registers . . . . .	37
<b>3</b>	<b>Applications</b> . . . . .	2	9.5.1	Interrupt register (address: 18H) . . . . .	37
<b>4</b>	<b>Ordering information</b> . . . . .	2	9.5.2	Chip ID register (address: 70H) . . . . .	38
<b>5</b>	<b>Block diagram</b> . . . . .	3	9.5.3	Frame Number register (address: 74H) . . . . .	39
<b>6</b>	<b>Pinning information</b> . . . . .	4	9.5.4	Scratch register (address: 78H) . . . . .	40
6.1	Pinning . . . . .	4	9.5.5	Unlock Device register (address: 7CH) . . . . .	40
6.2	Pin description . . . . .	5	9.5.6	Test Mode register (address: 84H) . . . . .	41
<b>7</b>	<b>Functional description</b> . . . . .	7	<b>10</b>	<b>Limiting values</b> . . . . .	42
7.1	USB 2.0 transceiver . . . . .	8	<b>11</b>	<b>Static characteristics</b> . . . . .	42
7.2	Philips Serial Interface Engine (SIE) . . . . .	9	<b>12</b>	<b>Dynamic characteristics</b> . . . . .	44
7.3	Voltage regulators . . . . .	9	12.1	High-speed signals . . . . .	46
7.4	Memory Management Unit (MMU) and integrated RAM . . . . .	9	12.1.1	Template 1 (transmit waveform; device without captive cable) . . . . .	47
7.5	SoftConnect . . . . .	9	12.1.2	Template 2 (transmit waveform; device with captive cable) . . . . .	48
7.6	Bit clock recovery . . . . .	9	12.1.3	Template 3 (receive waveform; receiver sensitivity with captive cable) . . . . .	49
7.7	Multiplying PLL oscillator . . . . .	9	12.1.4	Template 4 (receive waveform; receiver sensitivity without captive cable) . . . . .	50
7.8	Microcontroller Interface and Microcontroller Handler . . . . .	10	12.2	Timing symbols . . . . .	51
7.9	DMA Interface and DMA Handler . . . . .	10	12.3	Parallel I/O timing . . . . .	52
7.10	System Controller . . . . .	10	12.3.1	Generic Processor mode (BUS_CONF = 1) . . . . .	52
<b>8</b>	<b>Modes of operation</b> . . . . .	11	12.3.2	Split Bus mode (BUS_CONF = 0) . . . . .	53
<b>9</b>	<b>Register descriptions</b> . . . . .	11	12.4	DMA timing . . . . .	54
9.1	Register access . . . . .	13	12.4.1	PIO mode . . . . .	54
9.2	Initialization registers . . . . .	13	12.4.2	GDMA slave mode . . . . .	56
9.2.1	Address register (address: 00H) . . . . .	13	12.4.3	MDMA mode . . . . .	59
9.2.2	Mode register (address: 0CH) . . . . .	14	12.4.4	UDMA mode . . . . .	60
9.2.3	Interrupt Configuration register (address: 10H) . . . . .	15	<b>13</b>	<b>Application information</b> . . . . .	65
9.2.4	Interrupt Enable register (address: 14H) . . . . .	16	<b>14</b>	<b>Test information</b> . . . . .	66
9.2.5	DMA Configuration register (address: 38H) . . . . .	17	<b>15</b>	<b>Package outline</b> . . . . .	67
9.2.6	DMA Hardware register (address: 3CH) . . . . .	17	<b>16</b>	<b>Soldering</b> . . . . .	68
9.3	Data flow registers . . . . .	18	16.1	Introduction to soldering surface mount packages . . . . .	68
9.3.1	Endpoint Index register (address: 2CH) . . . . .	18	16.2	Reflow soldering . . . . .	68
9.3.2	Control Function register (address: 28H) . . . . .	19	16.3	Wave soldering . . . . .	68
9.3.3	Data Port register (address: 20H) . . . . .	19	16.4	Manual soldering . . . . .	69
9.3.4	Buffer Length register (address: 1CH) . . . . .	20	16.5	Package related soldering information . . . . .	69
9.3.5	Endpoint MaxPacketSize register (address: 04H) . . . . .	21	<b>17</b>	<b>Revision history</b> . . . . .	70
9.3.6	Endpoint Type register (address: 08C) . . . . .	22	<b>18</b>	<b>Data sheet status</b> . . . . .	71
9.3.7	Short Packet register (address: 24H) . . . . .	22	<b>19</b>	<b>Definitions</b> . . . . .	71
9.4	DMA registers . . . . .	24	<b>20</b>	<b>Disclaimers</b> . . . . .	71
9.4.1	DMA Command register (address: 30H) . . . . .	26	<b>21</b>	<b>Trademarks</b> . . . . .	71
9.4.2	DMA Transfer Counter register (address: 34H) . . . . .	27			
9.4.3	DMA Configuration register (address: 38H) . . . . .	28			
9.4.4	DMA Hardware register (address: 3CH) . . . . .	30			
9.4.5	DMA Strobe Timing register (address: 60H) . . . . .	31			
9.4.6	Task File registers (addresses: 40H to 4FH) . . . . .	32			
9.4.7	DMA Interrupt Reason register (address: 50H) . . . . .	35			
9.4.8	DMA Interrupt Enable register (address: 54H) . . . . .	36			



# PHILIPS

*Let's make things better.*