

MSRP10040

SWITCHMODE™ Soft Recovery Power Rectifier

POWERTAP™ III Package

State of the art geometry features epitaxial construction with glass passivation and metal overlay contact. Ideally suited for low voltage, high frequency switching power supplies, free wheeling diode and polarity protection diodes.

- Soft Recovery Rectifier
- Low I_{RRM} Losses
- Highly Stable Glass Passivated Junction

Mechanical Characteristics:

- Dual Die Construction
- Case: Epoxy, Molded with Plated Copper Heatsink Base
- Weight: 40 Grams (approximately)
- Finish: All External Surfaces Corrosion Resistant
- Top Terminal Torque: 25 – 40 lb-in max.
- Shipped 50 Units per Foam
- Marking: MSRP10040

MAXIMUM RATINGS

Rating	Symbol	Max	Unit
Peak Repetitive Reverse Voltage Working Peak Reverse Voltage DC Blocking Voltage	V_{RRM} V_{RWM} V_R	400	V
Average Rectified Forward Current (At Rated V_R , $T_C = 100^\circ\text{C}$)	I_O	100	A
Peak Repetitive Forward Current (At Rated V_R , Square Wave, 100 kHz, $T_C = \text{TBD}^\circ\text{C}$)	I_{FRM}	200	A
Non-Repetitive Peak Surge Current (Surge Applied at Rated Load Conditions Halfwave, Single Phase, 60 Hz)	I_{FSM}	800	A
Storage/Operating Case Temperature Range	T_{stg}, T_C	-55 to +150	$^\circ\text{C}$
Operating Junction Temperature Range	T_J	-55 to +150	$^\circ\text{C}$



ON Semiconductor™

<http://onsemi.com>

SOFT RECOVERY
RECTIFIER
100 AMPERES
400 VOLTS

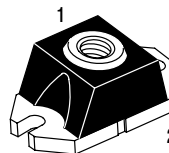

POWERTAP III
CASE 357D
PLASTIC

MARKING DIAGRAM

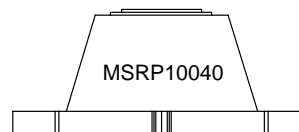

MSRP10040 = Device Code

ORDERING INFORMATION

Device	Package	Shipping
MSRP10040	POWERTAP III	50 Units/Tray

MSRP10040

THERMAL CHARACTERISTICS

Rating	Symbol	Value	Unit
Thermal Resistance — Junction-to-Case	$R_{\theta JC}$	0.5	$^{\circ}C/W$

ELECTRICAL CHARACTERISTICS

Typical Instantaneous Forward Voltage (Note 1.) ($I_F = 100\text{ A}$) ($I_F = 200\text{ A}$)	V_F	$T_J = 25^{\circ}C$	$T_J = 100^{\circ}C$	Volts
		1.75 2.00	1.25 1.50	
Typical Instantaneous Reverse Current ($V_R = 400\text{ V}$) ($V_R = 200\text{ V}$)	I_R	$T_J = 25^{\circ}C$	$T_J = 100^{\circ}C$	μA
		100 50	500 250	
Typical Reverse Recovery Time (Note 2.) ($V_R = 30\text{ V}$, $I_F = 10\text{ A}$, $di/dt = 200\text{ A}/\mu s$)	t_{rr}	75		ns
Typical Peak Reverse Recovery Current ($V_R = 30\text{ V}$, $I_F = 10\text{ A}$, $di/dt = 200\text{ A}/\mu s$)	I_{rm}	7.0		Amps

1. Pulse Test: Pulse Width $\leq 250\ \mu s$, Duty Cycle $\leq 2\%$.
2. t_{rr} measured projecting from 25% of IRM to zero.

MSRP10040

PACKAGE DIMENSIONS

POWERTAP III
CASE 357D-01
ISSUE A

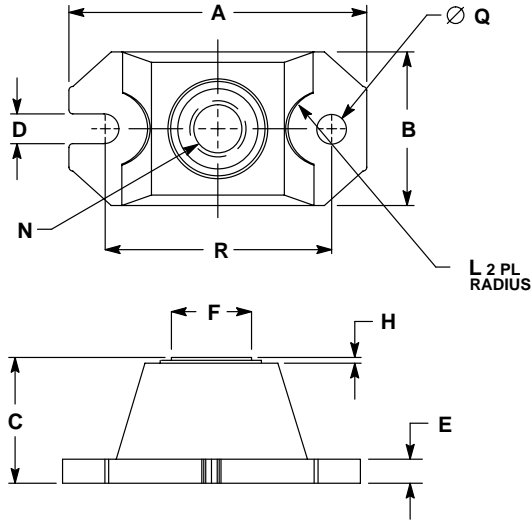

- NOTES:
1. DIMENSIONING AND TOLERANCING PER ANSI Y14.5M, 1982.
 2. CONTROLLING DIMENSION: INCH.
 3. TERMINAL PENETRATION: 5.97 (0.235) MAXIMUM.

DIM	INCHES		MILLIMETERS	
	MIN	MAX	MIN	MAX
A	1.520	1.560	38.61	39.62
B	0.783	0.813	19.89	20.65
C	0.615	0.635	15.62	16.13
D	0.152	0.162	3.86	4.11
E	0.120	0.130	3.05	3.30
F	0.435	0.445	11.05	11.30
H	0.007	0.030	0.18	0.76
L	0.210	0.230	5.33	5.84
N	1/4-20UNC-2B		1/4-20UNC-2B	
Q	0.152	0.162	3.86	4.11
R	1.175	1.195	29.85	30.35

POWERTAP and SWITCHMODE are trademarks of Semiconductor Components Industries, LLC.

ON Semiconductor and  are trademarks of Semiconductor Components Industries, LLC (SCILLC). SCILLC reserves the right to make changes without further notice to any products herein. SCILLC makes no warranty, representation or guarantee regarding the suitability of its products for any particular purpose, nor does SCILLC assume any liability arising out of the application or use of any product or circuit, and specifically disclaims any and all liability, including without limitation special, consequential or incidental damages. "Typical" parameters which may be provided in SCILLC data sheets and/or specifications can and do vary in different applications and actual performance may vary over time. All operating parameters, including "Typicals" must be validated for each customer application by customer's technical experts. SCILLC does not convey any license under its patent rights nor the rights of others. SCILLC products are not designed, intended, or authorized for use as components in systems intended for surgical implant into the body, or other applications intended to support or sustain life, or for any other application in which the failure of the SCILLC product could create a situation where personal injury or death may occur. Should Buyer purchase or use SCILLC products for any such unintended or unauthorized application, Buyer shall indemnify and hold SCILLC and its officers, employees, subsidiaries, affiliates, and distributors harmless against all claims, costs, damages, and expenses, and reasonable attorney fees arising out of, directly or indirectly, any claim of personal injury or death associated with such unintended or unauthorized use, even if such claim alleges that SCILLC was negligent regarding the design or manufacture of the part. SCILLC is an Equal Opportunity/Affirmative Action Employer.

PUBLICATION ORDERING INFORMATION

NORTH AMERICA Literature Fulfillment:

Literature Distribution Center for ON Semiconductor
P.O. Box 5163, Denver, Colorado 80217 USA
Phone: 303-675-2175 or 800-344-3860 Toll Free USA/Canada
Fax: 303-675-2176 or 800-344-3867 Toll Free USA/Canada
Email: ONlit@hibbertco.com
Fax Response Line: 303-675-2167 or 800-344-3810 Toll Free USA/Canada

N. American Technical Support: 800-282-9855 Toll Free USA/Canada

EUROPE: LDC for ON Semiconductor – European Support

German Phone: (+1) 303-308-7140 (Mon-Fri 2:30pm to 7:00pm CET)
Email: ONlit-german@hibbertco.com
French Phone: (+1) 303-308-7141 (Mon-Fri 2:00pm to 7:00pm CET)
Email: ONlit-french@hibbertco.com
English Phone: (+1) 303-308-7142 (Mon-Fri 12:00pm to 5:00pm GMT)
Email: ONlit@hibbertco.com

EUROPEAN TOLL-FREE ACCESS*: 00-800-4422-3781

*Available from Germany, France, Italy, UK, Ireland

CENTRAL/SOUTH AMERICA:

Spanish Phone: 303-308-7143 (Mon-Fri 8:00am to 5:00pm MST)
Email: ONlit-spanish@hibbertco.com
Toll-Free from Mexico: Dial 01-800-288-2872 for Access –
then Dial 866-297-9322

ASIA/PACIFIC: LDC for ON Semiconductor – Asia Support

Phone: 303-675-2121 (Tue-Fri 9:00am to 1:00pm, Hong Kong Time)
Toll Free from Hong Kong & Singapore:
001-800-4422-3781
Email: ONlit-asia@hibbertco.com

JAPAN: ON Semiconductor, Japan Customer Focus Center
4-32-1 Nishi-Gotanda, Shinagawa-ku, Tokyo, Japan 141-0031
Phone: 81-3-5740-2700
Email: r14525@onsemi.com

ON Semiconductor Website: <http://onsemi.com>

For additional information, please contact your local Sales Representative.