

### Ultrasonic Ceramic Sensors (Ultrasonic Ceramic Transducers)

Type: **U/H/S/Q/G**



Ultrasonic Ceramic Sensor consisting of a disc type/a bimorph type piezoelectric ceramic vibrator is a sensor for transmitting and receiving ultrasonic wave in the air.

#### ■ Features

- High output S.P.L.: 130 dB min. (Ex. EFRTGB38K1)
- High sensitivity: -45 dB min. (Ex. EFRRUB40K5)
- Excellent temperature and humidity durability
- Small in size

#### ■ Precautions for Safety (See Page 231)

#### ■ Recommended Applications

Ultrasonic wave transmitter and receiver for;

- Proximity switch for burglar alarm system, parking meter and automatic door opener
- Remote control equipment for such as air conditioner and garage door opener
- Detection of objects.
- Back alarm system for automobiles and distance meter.

#### ■ Explanation of Part Numbers

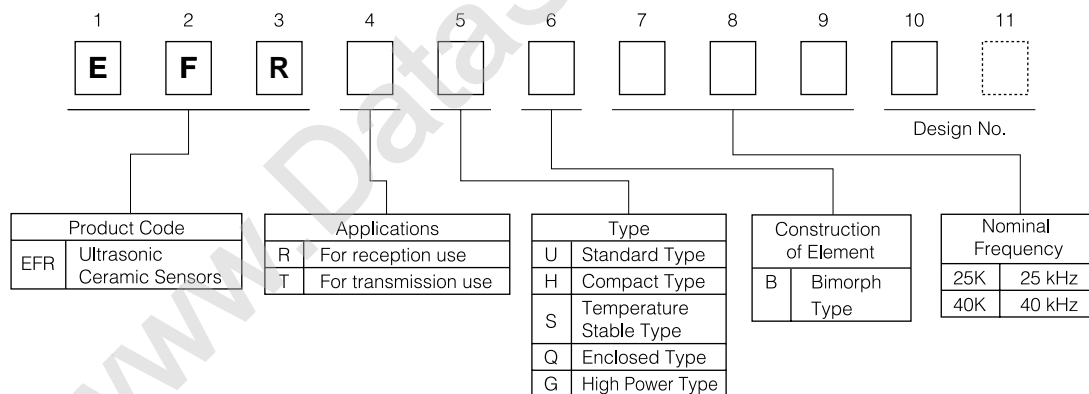

### ■ Ratings and Characteristics

Item	Type Part No.	Standard Type			
		EFRRUB40K5	EFRTUB40K5	EFRRUB25K5	EFRTUB25K5
Nominal Frequency	(kHz)	40.0	40.0	25.0	25.0
Sensitivity	(dB)*	-45 min.	—	-45 min.	—
Sound Pressure Level	(dB)**	—	112 min.	—	105 min.
Bandwidth	(kHz)	4.0 min.	4.0 min.	2.5 min.	2.5 min.
Application		Receiver	Transmitter	Receiver	Transmitter
Maximum Input Voltage	(Vrms)	—	20	—	20
Operating Temperature Range	(°C)	-20 to 60			

Item	Type Part No.	Compact Type		Temperature Stable Type	
		EFRRHB40K5	EFRTHB40K5	EFRRSB40K5	EFRTSB40K5
Nominal Frequency	(kHz)	40.0	40.0	40.0	40.0
Sensitivity	(dB)*	-47 min.	—	-50 min.	—
Sound Pressure Level	(dB)**	—	110 min.	—	105 min.
Bandwidth	(kHz)	4.0 min.	4.0 min.	4.0 min.	4.0 min.
Application		Receiver	Transmitter	Receiver	Transmitter
Maximum Input Voltage	(Vrms)	—	20	—	20
Operating Temperature Range	(°C)	-20 to 60		-40 to 100	

Item	Type Part No.	Enclosed Type		High Power Type	
		EFRRQB40K5	EFRTQB40K5	EFRRGB38K1	EFRTGB38K1
Nominal Frequency	(kHz)	40.0	40.0	38.0	38.0
Sensitivity	(dB)*	-55 min.	—	-55 min.	—
Sound Pressure Level	(dB)**	—	105 min.	—	130 min. (at 200 Vp-p)
Bandwidth	(kHz)	1.0 min.	1.0 min.	1.0 min.	1.0 min.
Application		Receiver	Transmitter	Receiver	Transmitter
Maximum Input Voltage	(Vrms)	—	20	—	200 Vp-p 2 ms ON, 200 ms period
Operating Temperature Range	(°C)	-20 to 60		-20 to 60	

\* 0 dB=1 V/Pa

\*\* 0 dB=2×10<sup>-5</sup> Pa

note: Combiend use Type Please contact us for more information.

Design, Specifications are subject to change without notice. Ask factory for technical specifications before purchase and/or use. Whenever a doubt about safety arises from this product, please inform us immediately for technical consultation without fail.

■ Dimensions in mm (not to scale)

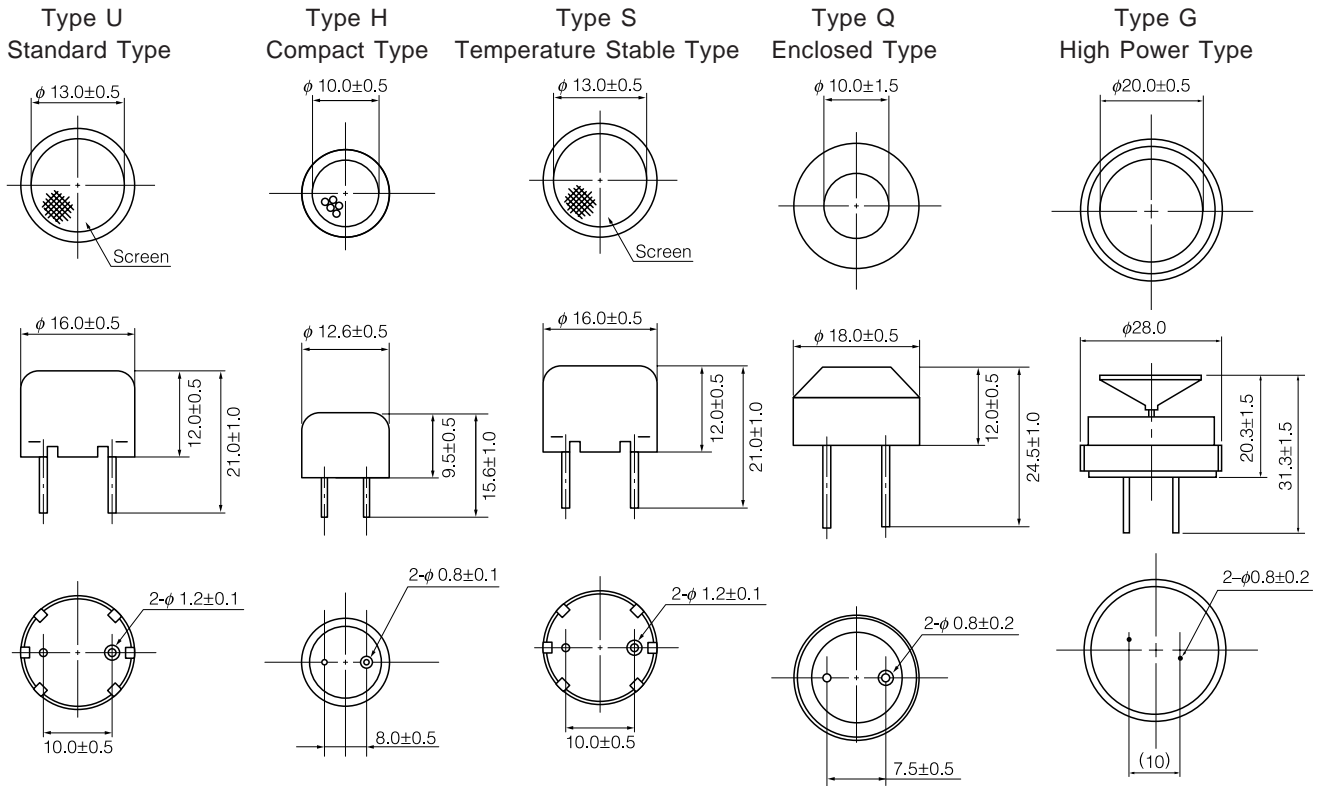

■ Test Circuits Diagram

Test Circuit Diagram for Receiver

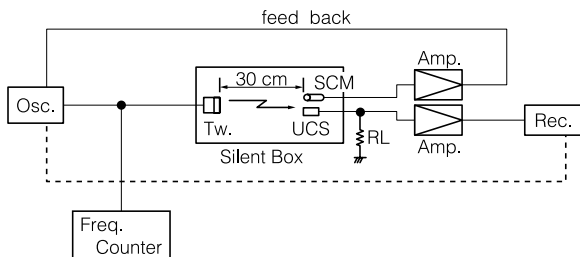

Test Circuit Diagram for Transmitter

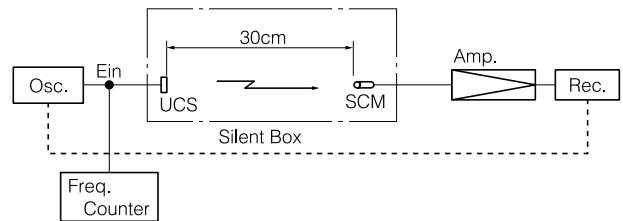

- RL : 3.9 k $\Omega$
- UCS : Ultrasonic Ceramic Sensor
- SCM : Standard Condenser Microphone Brüel & Kjær 4135
- Amp. : Amplifier Brüel & Kjær 2606
- Osc. : Oscillator Brüel & Kjær 1013
- Rec. : Recorder Brüel & Kjær 2305
- Tw. : Tweeter

- UCS : Ultrasonic Ceramic Sensor
- SCM : Standard Condenser Microphone Brüel & Kjær 4135
- Amp. : Amplifier Brüel & Kjær 2606
- Osc. : Oscillator Brüel & Kjær 1013
- Rec. : Recorder Brüel & Kjær 2305
- Ein : 10 Vrms.

[Sensitivity]

Output voltage of the specimen shall be measured in accordance with the specified Test Circuit and the specified test conditions. The output voltage shall be expressed in decibels (dB), where 1 V/Pa is 0 dB.

[Sound Pressure Level]

Maximum sound pressure level from the specimen shall be measured in accordance with the specified Test Circuit and the specified test conditions. The output sound pressure shall be expressed in decibels (dB), where  $2 \times 10^{-5}$  Pa is 0 dB.

## ■ Typical Characteristics

### Frequency Characteristics (Sensitivity)

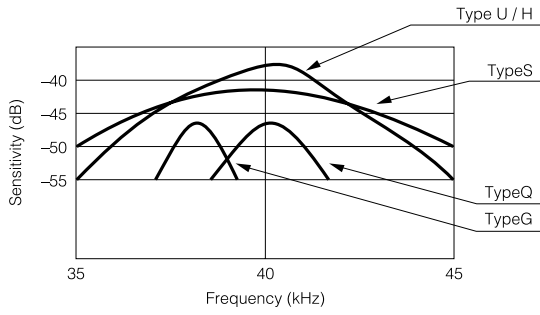

### Frequency Characteristics (Sound Pressure Level)

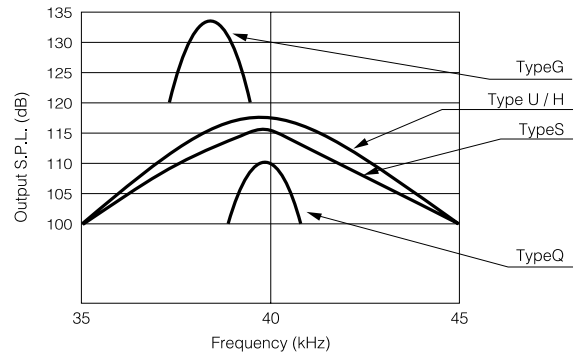

EFRRUB25K

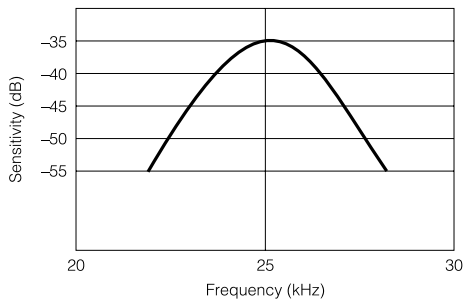

EFRTUB25K

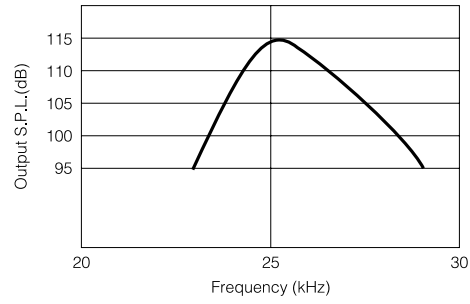

### Directivity

Type U/H/S

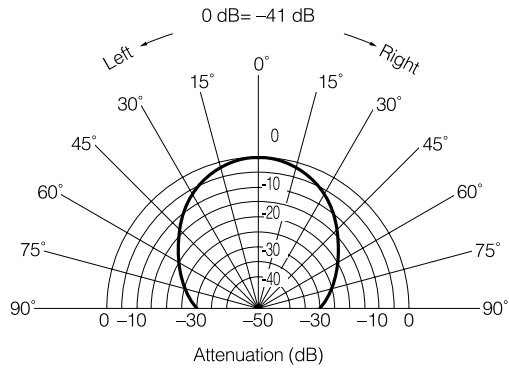

Type Q/G

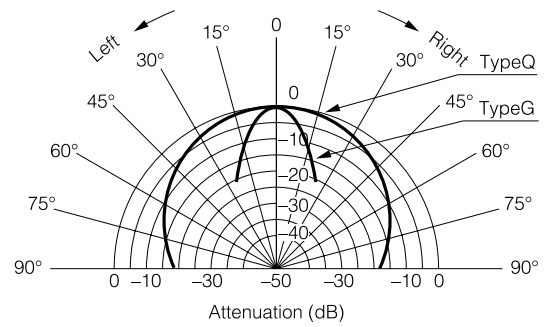

### Characteristic Change vs. Load Resistance

Type U/H/S (40 kHz)

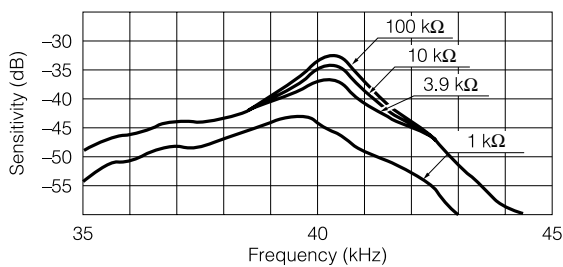

Type Q/G

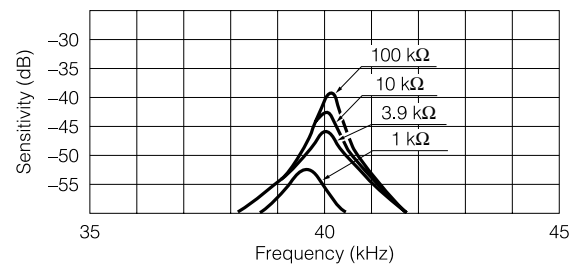

## Precautions for Handling

Because the Ultrasonic Sensors are designed for use in the air, they can not be used under the water or others liquid.

### ■ Design Engineering Notes

1. **Application of DC voltage**  
DC voltage shall not be applied to the Ultrasonic Sensors because insulation resistance may deteriorate.
2. **Maximum Input Voltage**  
The Ultrasonic Sensors shall not be operated beyond the specified "Maximum Input Voltage" in the catalog or the specifications.
3. **Characteristics change owing to load impedance**  
Center frequency and sensitivity change in accordance with load impedance. Therefore, the load characteristics chart shall be taken into consideration in designing circuit.
4. **In the Design of Transmitting Circuits**  
It shall be noted that the impedance of the device is as low as 500  $\Omega$  (approximately) at the resonance frequency.

### ■ Mounting Notes

1. **Installation**  
It is recommended to hold the Ultrasonic Sensors by means of rubber\* sheets or cushions for absorption of mechanical stresses such as shock and vibration.  
\*Except sulfurated rubber
2. **Soldering**  
Soldering of the lead terminals shall be done at a position of 2.5 mm or more apart from bottom plain of the devices.

### 3. Bending force to the Terminals

Abnormal bending force shall not be applied to the terminals of the Sensors, otherwise holding parts of the terminals may be easily broken, resulting in failures and damages of the devices.

### 4. Directivity

Please be careful enough in deciding facing position of the sensor because of directivity.

### ■ Storage Notes

#### 1. Environmental Conditions

- The Ultrasonic Sensors shall not be operated and/or stored under following environmental conditions;
- a) To be exposed directly to water or salt water.
  - b) Under conditions of dew formation or frost.
  - c) Under conditions of corrosive atmosphere such as hydrogen sulfide, sulfurous acid, chlorine and ammonia.

#### 2. Long Term Storage

The Ultrasonic Sensors shall not be stored under severe conditions of high temperature and high humidity. Store them indoors under 40 °C max. and 75 %RH max. Use them within one year and check the solderability before use.