

DESCRIPTION

The HI-1565 and HI-1566 are low power CMOS dual transceivers designed to meet the requirements of the MIL-STD-1553/1760 specifications.

The transmitter section of each bus takes complementary CMOS/TTL Manchester II bi-phase data and converts it to differential voltages suitable for driving the bus isolation transformer. Separate transmitter inhibit control signals are provided for each transmitter.

The receiver section of each bus converts the 1553 bus bi-phase differential data to complementary CMOS/TTL data suitable for inputting to a Manchester decoder. Each receiver has a separate enable input which can be used to force the output of the receiver to a logic 0 (HI-1565) or logic 1 (HI-1566).

To minimize the package size for this function, the transmitter outputs are internally connected to the receiver inputs, so that only two pins are required for connection to each coupling transformer.

FEATURES

- Compliant to MIL-STD-1553A & B, MIL-STD-1760, ARINC 708A
- CMOS technology for low standby power
- Smallest footprint available in 44-pin plastic chip-scale package with integral heatsink
- Less than 1.0W maximum power dissipation
- BUS pins ESD protected to greater than 8KV
- Also available in DIP and small outline (ESOIC) package options
- Industrial and extended temperature ranges
- Industry standard pin configurations

PIN CONFIGURATIONS

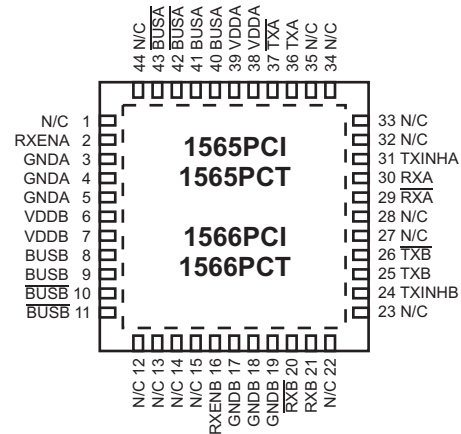

**44 Pin Plastic 7mm x 7mm
Chip-scale package**

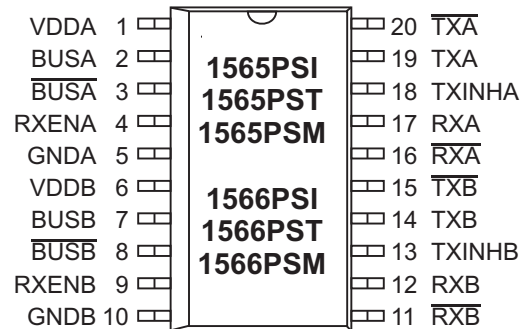

20 Pin Plastic ESOIC - WB package

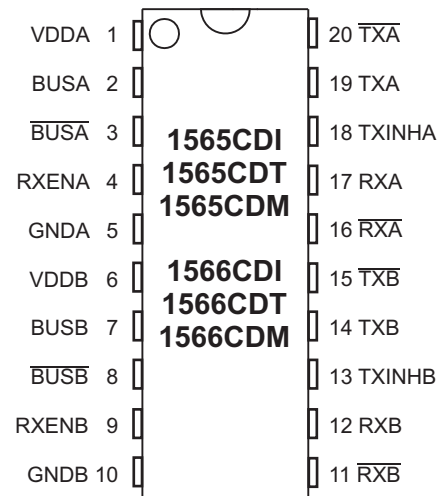

20 Pin Ceramic DIP package

PIN DESCRIPTIONS

PIN (DIP/ESQIC)	SYMBOL	FUNCTION	DESCRIPTION
1	VDDA	power supply	+5 volt power for bus A
2	BUSA	analog output	MIL-STD-1533 bus driver A, positive signal
3	\overline{BUSA}	analog output	MIL-STD-1553 bus driver A, negative signal
4	RXENA	digital input	Receiver A enable. If low, forces RXA and \overline{RXA} low (HI-1565) or High (HI-1566)
5	GND A	power supply	Ground for bus A
6	VDD B	power supply	+5 volt power for bus B
7	BUSB	analog output	MIL-STD-1533 bus driver B, positive signal
8	\overline{BUSB}	analog output	MIL-STD-1553 bus driver B, negative signal
9	RXENB	digital input	Receiver B enable. If low, forces RXB and \overline{RXB} low (HI-1565) or High (HI-1566)
10	GND B	power supply	Ground for bus B
11	\overline{RXB}	digital output	Receiver B output, inverted
12	RXB	digital output	Receiver B output, non-inverted
13	TXINH B	digital input	Transmit inhibit, bus B. If high BUSB, \overline{BUSB} disabled
14	TXB	digital input	Transmitter B digital data input, non-inverted
15	\overline{TXB}	digital input	Transmitter B digital data input, inverted
16	\overline{RXA}	digital output	Receiver A output, inverted
17	RXA	digital output	Receiver A output, non-inverted
18	TXINH A	digital input	Transmit inhibit, bus A. If high BUSA, \overline{BUSA} disabled
19	TXA	digital input	Transmitter A digital data input, non-inverted
20	\overline{TXA}	digital input	Transmitter A digital data input, inverted

FUNCTIONAL DESCRIPTION

The HI-1565 family of data bus transceivers contain differential voltage source drivers and differential receivers. They are intended for applications using a MIL-STD-1553 A/B data bus. The device produces a trapezoidal output waveform during transmission.

TRANSMITTER

Data input to the device's transmitter section is from the complementary CMOS /TTL inputs TXA/B and $\overline{TXA/B}$. The transmitter accepts Manchester II bi-phase data and converts it to differential voltages on BUSA/B and $\overline{BUSA/B}$. The transceiver outputs are either direct or transformer coupled to the MIL-STD-1553 data bus. Both coupling methods produce a nominal voltage on the bus of 7.5 volts peak to peak.

The transmitter is automatically inhibited and placed in the high impedance state when both TXA/B and $\overline{TXA/B}$ are either at a logic "1" or logic "0" simultaneously. A logic "1" applied to the TXINH A/B input will force the transmitter to the high impedance state, regardless of the state of TXA/B and $\overline{TXA/B}$.

RECEIVER

The receiver accepts bi-phase differential data from the MIL-STD-1553 bus through the same direct or transformer coupled interface as the transmitter. The receiver's differential input stage drives a filter and threshold comparator that produces CMOS/TTL data at the RXA/B and $\overline{RXA/B}$ output pins.

Each set of receiver outputs can be independently forced to a logic "0" (HI-1565) or logic "1" (HI-1566) by setting RXENA or RXENB low.

MIL-STD-1553 BUS INTERFACE

A direct coupled interface (see Figure 2) uses a 1:2.5 ratio isolation transformer and two 55 ohm isolation resistors between the transformer and the bus.

In a transformer coupled interface (see Figure 3), the transceiver is connected to a 1:1.79 isolation transformer which in turn is connected to a 1:1.4 coupling transformer. The transformer coupled method also requires two coupling resistors equal to 75% of the bus characteristic impedance (Z_0) between the coupling transformer and the bus.

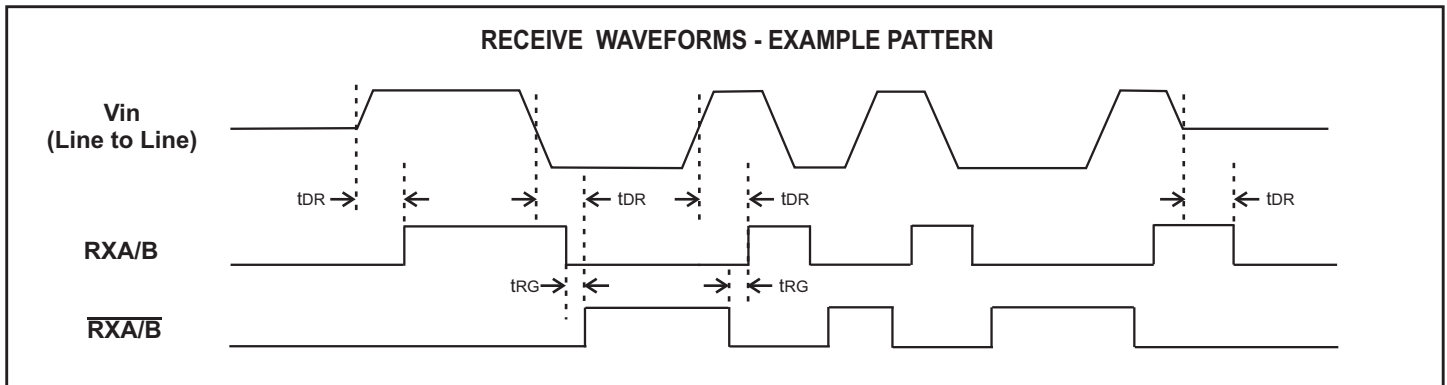
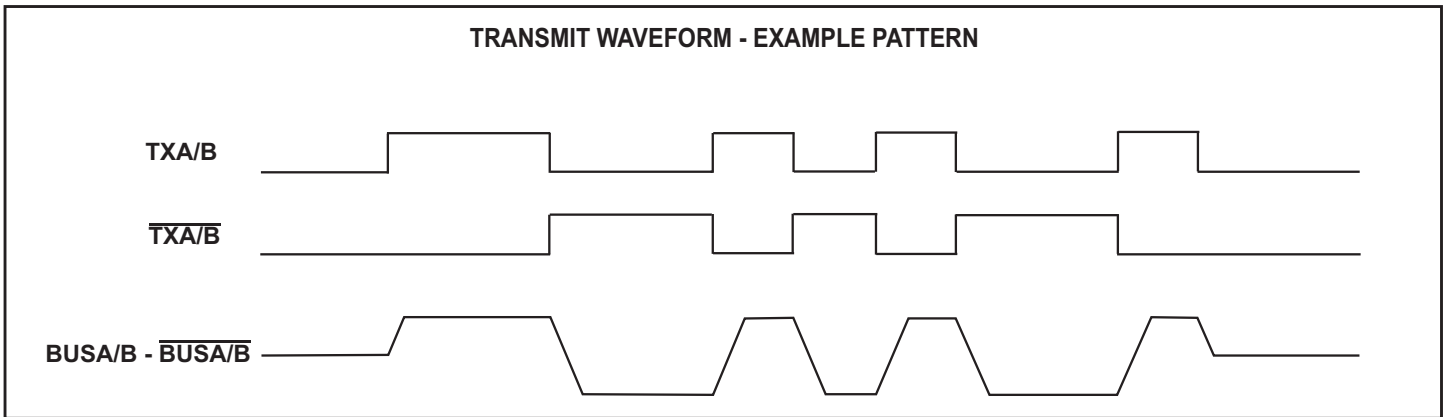
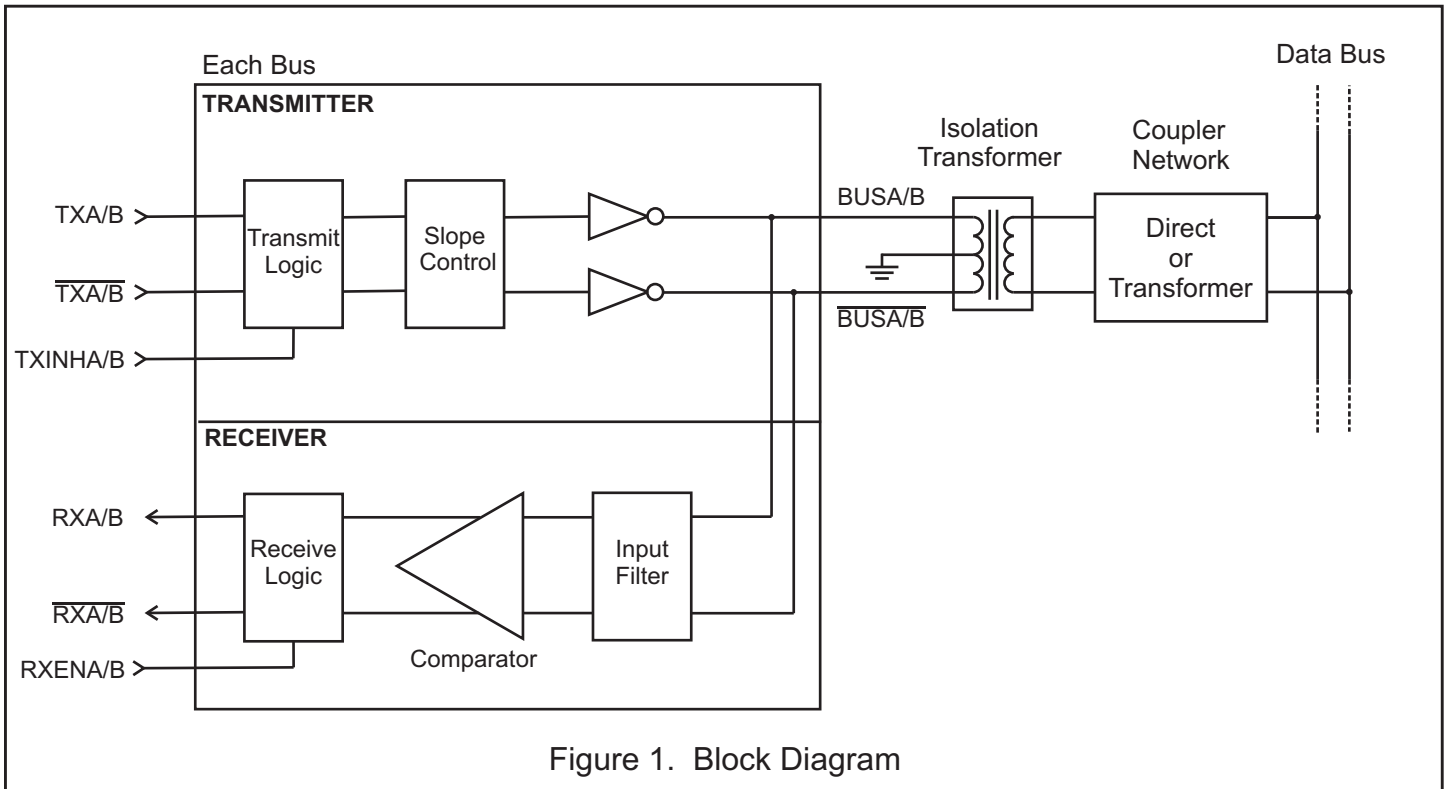

ABSOLUTE MAXIMUM RATINGS

Supply voltage (VDD)	-0.3 V to +7 V
Logic input voltage range	-0.3 V dc to +5.5 V
Receiver differential voltage	10 Vp-p
Driver peak output current	+1.0 A
Power dissipation at 25°C ceramic DIL, derate	1.0 W 7mW/°C
Solder Temperature	275°C for 10 sec.
Junction Temperature	175°C
Storage Temperature	-65°C to +150°C

RECOMMENDED OPERATING CONDITIONS

Supply Voltage
VDD..... 5V... ±5%
Temperature Range
Industrial Screening.....-40°C to +85°C
Hi-Temp Screening.....-55°C to +125°C

NOTE: Stresses above absolute maximum ratings or outside recommended operating conditions may cause permanent damage to the device. These are stress ratings only. Operation at the limits is not recommended.

DC ELECTRICAL CHARACTERISTICS

VDD = 5.0V, GND = 0V, TA = Operating Temperature Range (unless otherwise specified).

PARAMETER	SYMBOL	CONDITION	MIN	TYP	MAX	UNITS	
Operating Voltage	VDD		4.75	5	5.25	V	
Total Supply Current	ICC1	Not Transmitting		14	22	mA	
	ICC2	Transmit one bus @ 50% duty cycle		200	340	mA	
	ICC3	Transmit one bus @ 100% duty cycle		400	550	mA	
Power Dissipation	PD1	Not Transmitting			0.11	W	
	PD2	Transmit one bus @ 100% duty cycle		0.70	0.95	W	
Min. Input Voltage (HI)	V _{IH}	Digital inputs	2.0	1.4		V	
Max. Input Voltage (LO)	V _{IL}	Digital inputs		1.4	0.8	V	
Min. Input Current (HI)	I _{IH}	V _{IH} = 4.9V, Digital inputs			20	µA	
Max. Input Current (LO)	I _{IL}	V _{IL} = 0.1V, Digital inputs	-20			µA	
Min. Output Voltage (HI)	V _{OH}	I _{OUT} = -0.4mA, Digital outputs	2.7			V	
Max. Output Voltage (LO)	V _{IH}	I _{OUT} = 4.0mA, Digital outputs			0.4	V	
RECEIVER (Measured at Point "Ab" in Figure 2 unless otherwise specified)							
Input resistance	R _{IN}	Differential	20			Kohm	
Input capacitance	C _{IN}	Differential			5	pF	
Common mode rejection ratio	CMRR		40			dB	
Input Level	V _{IN}	Differential			9	Vp-p	
Input common mode voltage	V _{ICM}		-5.0		5.0	V-pk	
Threshold Voltage - Direct-coupled	Detect	V _{THD}	1 Mhz Sine Wave (Measured at Point "Ab" in Figure 2)		1.15	20.0	Vp-p
	No Detect	V _{THND}					
Threshold Voltage - Transformer-coupled	Detect	V _{THD}	1 MHz Sine Wave (Measured at Point "At" in Figure 3)		0.86	14.0	Vp-p
	No Detect	V _{THND}					

DC ELECTRICAL CHARACTERISTICS (cont.)

VDD = 5.0V, GND = 0V, TA = Operating Temperature Range (unless otherwise specified).

PARAMETER	SYMBOL	CONDITION	MIN	TYP	MAX	UNITS
TRANSMITTER (Measured at Point "Ad" in Figure 2 unless otherwise specified)						
Output Voltage	Direct coupled	V _{OUT}	35 ohm load (Measured at Point "Ad" in Figure 2)	7.0	9.0	Vp-p
	Transformer coupled	V _{OUT}	70 ohm load (Measured at Point "At" in Figure 3)	20.0	27.0	Vp-p
Output Noise		V _{ON}	Differential, inhibited		10.0	mVp-p
Output Dynamic Offset Voltage	Direct coupled	V _{DYN}	35 ohm load (Measured at Point "Ad" in Figure 2)	-90	90	mV
	Transformer coupled	V _{DYN}	70 ohm load (Measured at Point "At" in Figure 3)	-250	250	mV
Output resistance		R _{OUT}	Differential, not transmitting	10		Kohm
Output Capacitance		C _{OUT}	1 MHz sine wave		15	pF

AC ELECTRICAL CHARACTERISTICS

VDD = 5.0V, GND = 0V, TA = Operating Temperature Range (unless otherwise specified).

PARAMETER	SYMBOL	TEST CONDITIONS	MIN	TYP	MAX	UNITS
RECEIVER (Measured at Point "Ad" in Figure 2)						
Receiver Delay	t _{DR}	From input zero crossing to RXA/B or $\overline{RXA/B}$			450	ns
Receiver gap time	t _{RG}	Spacing between RXA/B and $\overline{RXA/B}$ pulses	90		365	ns
Receiver Enable Delay	t _{REN}	From RXENA/B rising or falling edge to RXA/B or $\overline{RXA/B}$			40	ns
TRANSMITTER (Measured at Point "Ad" in Figure 2)						
Driver Delay	t _{DT}	TXA/B, TXA/B to BUSA/B, BUSA/B			150	ns
Rise time	t _r	35 ohm load	100		300	ns
Fall Time	t _f	35 ohm load	100		300	ns
Inhibit Delay	t _{DI-H}	Inhibited output			100	ns
	t _{DI-L}	Active output			150	ns

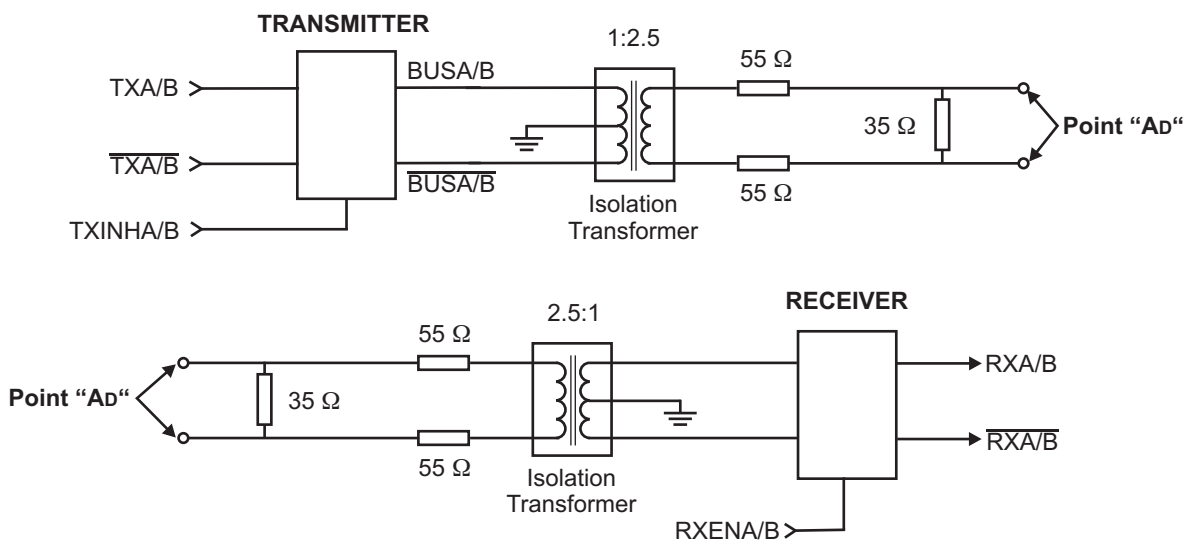

Figure 2. Direct Coupled Test Circuits

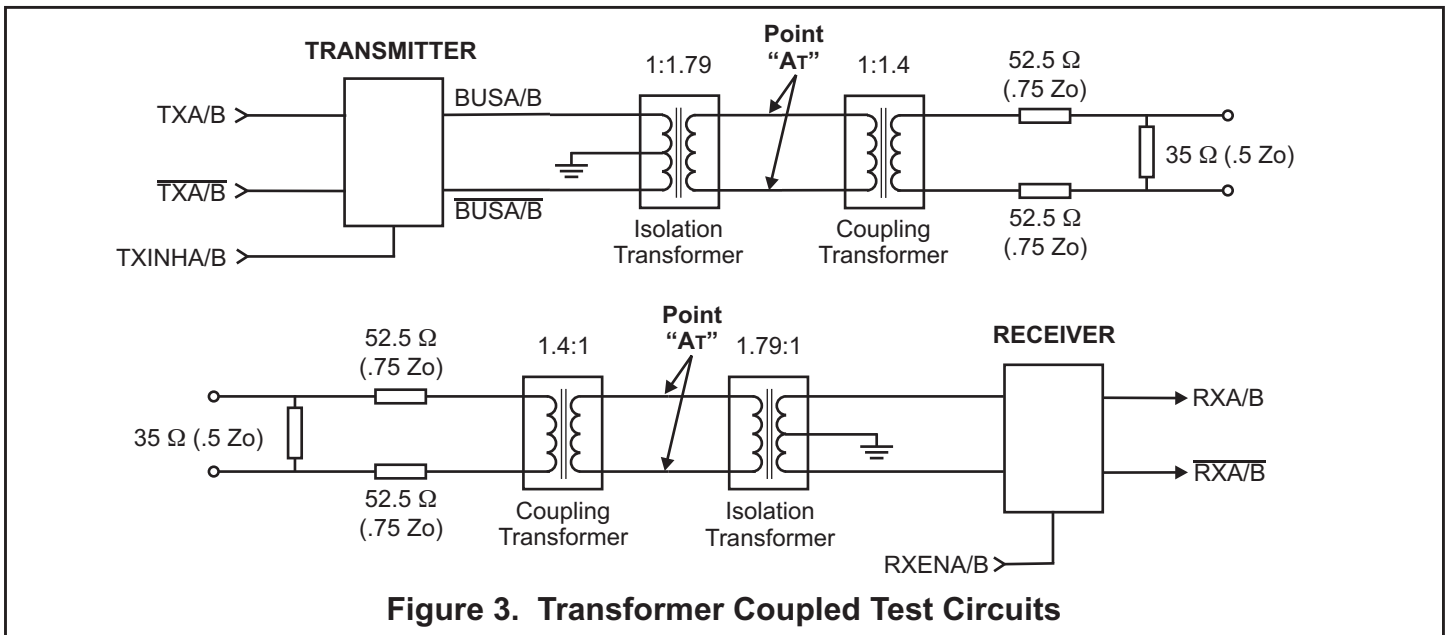

Figure 3. Transformer Coupled Test Circuits

HEAT SINK - ESOIC & CHIP-SCALE PACKAGE

Both the HI-1565PSI/T/M and HI-1566PSI/T/M use a 20-pin thermally enhanced SOIC package. The HI-1565PCI/T and HI-1566PCI/T use a plastic chip-scale package. These packages include a metal heat sink located on the bottom surface of the device. This heat

sink should be soldered down to the printed circuit board for optimum thermal dissipation. The heat sink is electrically isolated and may be soldered to any convenient power or ground plane..

THERMAL CHARACTERISTICS

PART NUMBER	PACKAGE STYLE	CONDITION	θ_{JA}	JUNCTION TEMPERATURE		
				$T_A=25^\circ\text{C}$	$T_A=85^\circ\text{C}$	$T_A=125^\circ\text{C}$
HI-1565PSI / T / M	20-pin Thermally enhanced plastic SOIC (ESOIC)	Heat sink unsoldered	54°C/W	62°C	122°C	162°C
HI-1566PSI / T / M		Heat sink soldered	47°C/W	57°C	117°C	157°C
HI-1565CDI / T / M HI-1566CDI / T / M	20-pin Ceramic side-brazed DIP	Socketed	62°C/W	69°C	129°C	169°C
HI-1565PCI / T HI-1566PCI / T	44-pin Plastic chip-scale package	Heat sink unsoldered	49°C/W	59°C	119°C	159°C

Data taken at VDD=5.0V, continuous transmission at 1Mbit/s, single transmitter enabled.

APPLICATIONS NOTE

Holt Applications Note AN-500 provides circuit design notes regarding the use of Holt's family of MIL-STD-1553 transceivers. Layout considerations, as well as recommended interface and protection components are included.

ORDERING INFORMATION

HI - 156x xx x x (Plastic)

PART NUMBER	LEAD FINISH
Blank	Tin / Lead (Sn / Pb) Solder
F	100% Matte Tin (Pb-free, RoHS compliant)

PART NUMBER	TEMPERATURE RANGE	FLOW	BURN IN
I	-40°C TO +85°C	I	NO
T	-55°C TO +125°C	T	NO
M	-55°C TO +125°C	M	YES

PART NUMBER	PACKAGE DESCRIPTION
PC	44 PIN PLASTIC CHIP-SCALE LPCC (44PCS) not available with 'M' flow
PS	20 PIN PLASTIC ESOIC, Thermally Enhanced Wide SOIC w/Heat Sink (20HWE)

PART NUMBER	RXENA = 0		RXENB = 0	
	RXA	RXA	RXB	RXB
1565	0	0	0	0
1566	1	1	1	1

HI - 156xCD x (Ceramic)

PART NUMBER	TEMPERATURE RANGE	FLOW	BURN IN	LEAD FINISH
I	-40°C TO +85°C	I	NO	Gold (Pb-free, RoHS compliant)
T	-55°C TO +125°C	T	NO	Gold (Pb-free, RoHS compliant)
M	-55°C TO +125°C	M	YES	Tin / Lead (Sn / Pb) Solder

PART NUMBER	RXENA = 0		RXENB = 0		PACKAGE DESCRIPTION
	RXA	RXA	RXB	RXB	
1565CD	0	0	0	0	20 PIN CERAMIC SIDE BRAZED DIP (20C)
1566CD	1	1	1	1	20 PIN CERAMIC SIDE BRAZED DIP (20C)

RECOMMENDED TRANSFORMERS

The HI-1565 and HI-1566 transceivers have been characterized for compliance with the electrical requirements of MIL-STD-1553 when used with the following

transformers. Holt recommends the Premier Magnetics parts as offering the best combination of electrical performance, low cost and small footprint.

MANUFACTURER	PART NUMBER	APPLICATION	TURNS RATIO(S)	DIMENSIONS
Premier Magnetics	PM-DB2725EX	Isolation	Dual tapped 1:1.79, 1:2.5	.500 x .500 x .375 inches
Technotrol	TL1553-45	Isolation	Dual tapped 1:1.79, 1:2.5	.630 x .630 x .155 inches
Premier Magnetics	PM-DB2702	Stub coupling	1:1.4	.625 x .625 x .250 inches
Technotrol	TQ1553-2	Stub coupling	1:1.4	.625 x .625 x .250 inches

REVISION HISTORY

Document	Rev.	Date	Description of Change
DS1565	E	09/26/08	Clarification of transmitter and receiver functions in Description, clarified available temperature ranges, and corrected a dimension in Recommended Transformers table.
	F	07/24/09	Corrected typographical errors in package dimensions.

20-PIN PLASTIC SMALL OUTLINE (ESOC) - WB
(Wide Body, Thermally Enhanced)

inches (millimeters)
Package Type: 20HWE

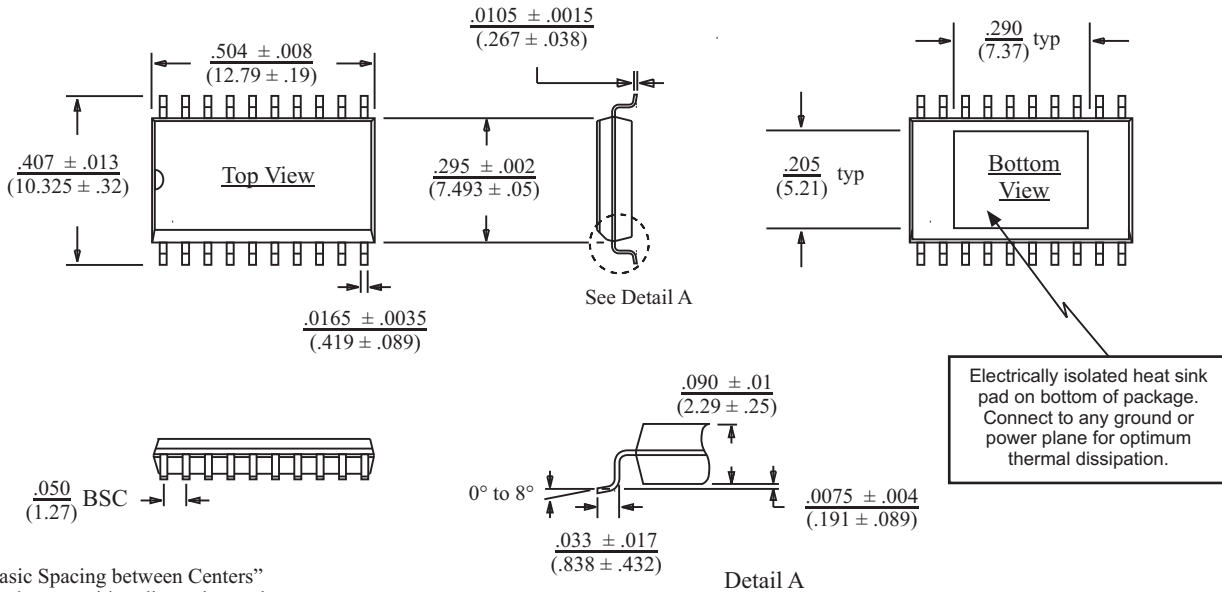

BSC = "Basic Spacing between Centers" is theoretical true position dimension and has no tolerance. (JEDEC Standard 95)

20-PIN CERAMIC SIDE-BRAZED DIP

inches (millimeters)
Package Type: 20C

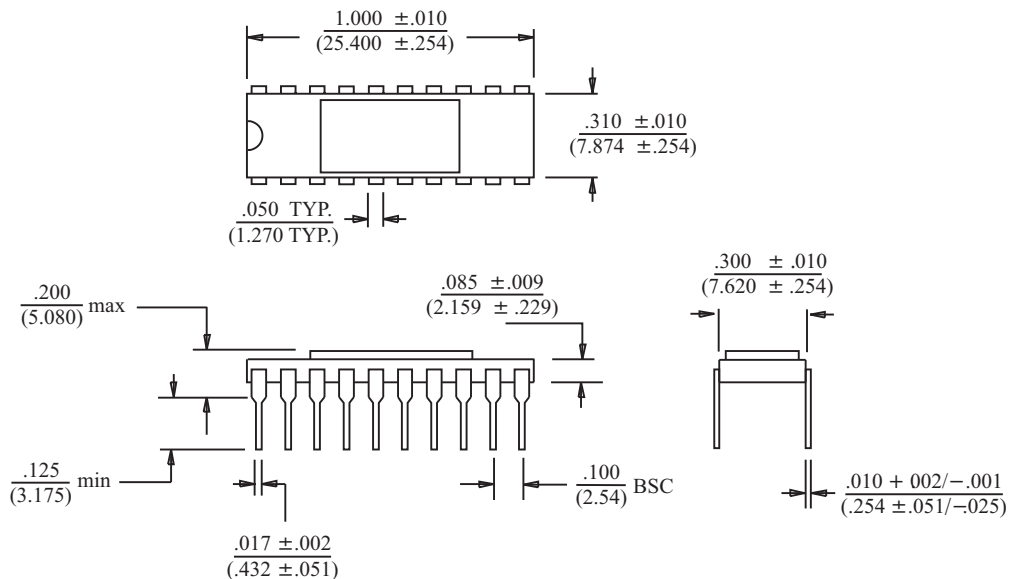

BSC = "Basic Spacing between Centers" is theoretical true position dimension and has no tolerance. (JEDEC Standard 95)

44-PIN PLASTIC CHIP-SCALE PACKAGE

inches (millimeters)

Package Type: 44PCS

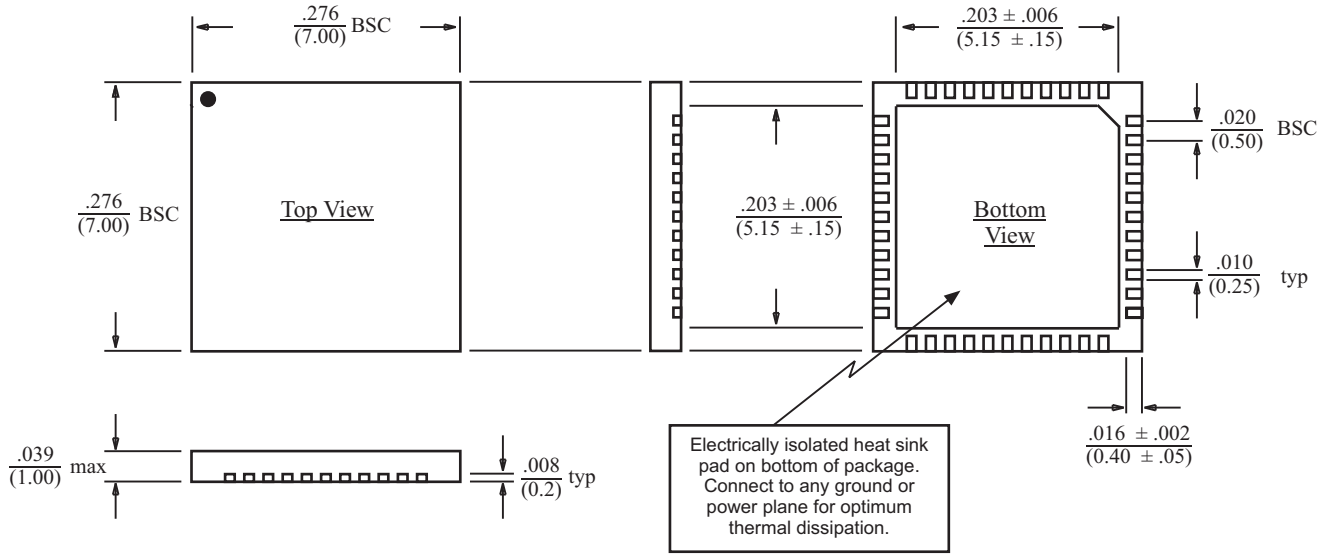

BSC = "Basic Spacing between Centers"
is theoretical true position dimension and
has no tolerance. (JEDEC Standard 95)