

MECHANICAL DATA

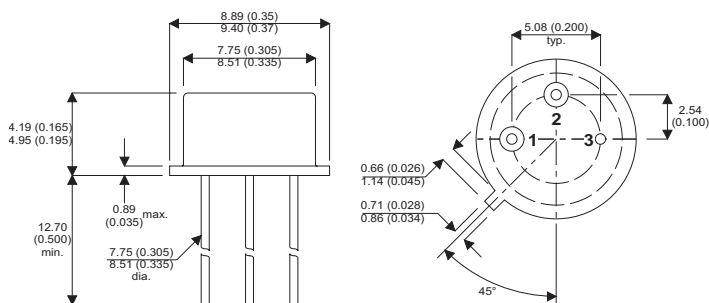

H Package - TO-39 Metal

Pin 1 = Ground Pin 2 = Vout Pin 3 = Vin

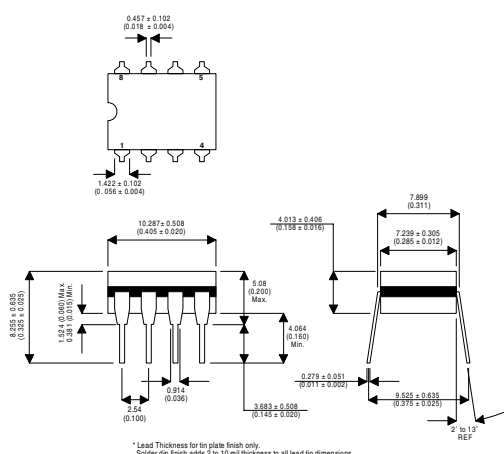

J Package = 8 Pin Ceramic DIP

Pin 1 = Ground Pin 5 = N/C
Pin 2 = N/C Pin 6 = Vin
Pin 3 = N/C Pin 7 = N/C
Pin 4 = Vout Pin 8 = N/C

**5 VOLT NEGATIVE
VOLTAGE REGULATOR**

FEATURES

- 0.01%/V LINE REGULATION
- 0.3%/A LOAD REGULATION
- THERMAL OVERLOAD PROTECTION
- SHORT CIRCUIT PROTECTION
- SAFE OPERATING AREA PROTECTION
- 1% OUTPUT VOLTAGE TOLERANCE

DESCRIPTION

The IP79M05AHX and IP79M05AJX are 5V negative 1.5A Voltage Regulators providing 0.01% per Volt Line Regulator and 0.3% per amp load regulation.

Protection includes safe operating Area current limiting and thermal.

ABSOLUTE MAXIMUM RATINGS ($T_{case} = 25^{\circ}C$ unless otherwise stated)

V_I	DC Input Voltage $V_O = -5V$	35V
P_D	Power Dissipation	Internally limited
T_j	Operating Junction Temperature Range	-55°C to +150°C
	Maximum Junction Temperature	150°C
T_{stg}	Storage Temperature Range	-65°C to +150°C
T_L	Lead Temperature (Soldering, 10 sec)	300°C

Semelab Plc reserves the right to change test conditions, parameter limits and package dimensions without notice. Information furnished by Semelab is believed to be both accurate and reliable at the time of going to press. However Semelab assumes no responsibility for any errors or omissions discovered in its use. Semelab encourages customers to verify that datasheets are current before placing orders.

ELECTRICAL CHARACTERISTICS ($T_j = 25^\circ\text{C}$ unless stated)

Parameter	Test Conditions	Min.	Typ.	Max.	Unit
V_O Output Voltage*	$I_O = 100\text{mA}$ $V_{IN} = 10\text{V}$	- 4.95	- 5	- 5.05	V
	$I_O = 5\text{mA to } 350\text{mA}$ $P_D \leq P_{MAX}$ $T_j = -55 \text{ to } +150^\circ\text{C}$	- 4.85		- 5.15 ($V_{IN} = - 7.5 \text{ to } - 20\text{V}$)	
ΔV_O Line Regulation*	$I_O = 200\text{mA}$		3 ($V_{IN} = - 7 \text{ to } - 25\text{V}$)	10	mV
	$I_O = 200\text{mA}$ $T_j = -55 \text{ to } +150^\circ\text{C}$		3 ($V_{IN} = - 8 \text{ to } - 25\text{V}$)	10	
	$I_O = 500\text{mA}$		3 ($V_{IN} = 8 \text{ to } 12\text{V}$)	10	
ΔV_O Load Regulation*	$I_O = 5\text{mA to } 500\text{mA}$ $V_{IN} = 10\text{V}$ $T_j = -55 \text{ to } +150^\circ\text{C}$		5	50	mV
I_d Quiescent Current*	$I_O = 350\text{mA}$ $V_{IN} = 10\text{V}$ $T_j = -55 \text{ to } +150^\circ\text{C}$		4	6	mA
ΔI_Q Quiescent Current Change*	$I_O = 5 \text{ to } 500 \text{ mA}$ $V_{IN} = 10\text{V}$ $T_j = -55 \text{ to } +150^\circ\text{C}$		0.1	0.5	mA
	$I_O = 200\text{mA}$ $T_j = -55 \text{ to } +150^\circ\text{C}$		0.2 ($V_{IN} = - 8 \text{ to } - 25\text{V}$)	0.8	mA
V_N Output Noise Voltage	$f = 10\text{Hz to } 100\text{kHz}$		40	200	μV
$\frac{\Delta V_{IN}}{\Delta V_O}$ Ripple Rejection	$f = 120\text{Hz}$ $I_O = 300\text{mA}$	65	80 ($V_{IN} = - 8 \text{ to } - 18\text{V}$)		dB
	$f = 120\text{Hz}$ $I_O = 100\text{mA}$ $T_j = -55 \text{ to } +150^\circ\text{C}$	65	80 ($V_{IN} = - 8 \text{ to } - 8\text{V}$)		dB
Dropout Voltage*	$I_O = 350\text{mA}$		2	2.5	V
I_{SC} Short Circuit Current*	$V_{IN} = 35\text{V}$		600	1200	mA
I_{PK} Peak Output Current*	$V_{IN} = 10\text{V}$	0.7	2.4	3.3	A
Average Temperature Coefficient of Output Voltage*	$I_O = 5\text{mA}$		0.5	2.0	mV / $^\circ\text{C}$

* Pulse Test: $t_p \leq 10\text{ms}$, $\delta \leq 5\%$.

All characteristics are measured with a capacitor across the input of $0.22\mu\text{F}$ and a capacitor across the output of $0.1\mu\text{F}$. Output Voltage changes due to changes in internal temperature must be taken into account separately.

Although power dissipation is internally limited, these specifications apply for up to 2W for the TO-39 package, and 1.05W for the Cerdip (J package).

THERMAL DATA

$R_{THj-case}$	Thermal Resistance Junction – Case	TO-39 (H Package)	$20^\circ\text{C} / \text{W Typ.}$
$R_{THj-amb}$	Thermal Resistance Junction – Ambient	Cerdip (J Package)	$120^\circ\text{C} / \text{W Typ.}$
	Derate above 25°C	Cerdip (J Package)	$8.4 \text{ mW} / ^\circ\text{C}$

Semelab Plc reserves the right to change test conditions, parameter limits and package dimensions without notice. Information furnished by Semelab is believed to be both accurate and reliable at the time of going to press. However Semelab assumes no responsibility for any errors or omissions discovered in its use. Semelab encourages customers to verify that datasheets are current before placing orders.