

D3SBA10 ~ D3SBA80

PRV : 100 ~ 800 Volts

I_o : 4.0 Amperes

FEATURES :

- * High current capability
- * High surge current capability
- * High reliability
- * Low reverse current
- * Low forward voltage drop
- * Ideal for printed circuit board
- * Very good heat dissipation
- * **Pb / RoHS Free**

MECHANICAL DATA :

- * Case : Reliable low cost construction utilizing molded plastic technique
- * Epoxy : UL94V-O rate flame retardant
- * Terminals : Plated lead solderable per MIL-STD-202, Method 208 guaranteed
- * Polarity : Polarity symbols marked on case
- * Mounting position : Any
- * Weight : 4.28 grams

SILICON BRIDGE RECTIFIER

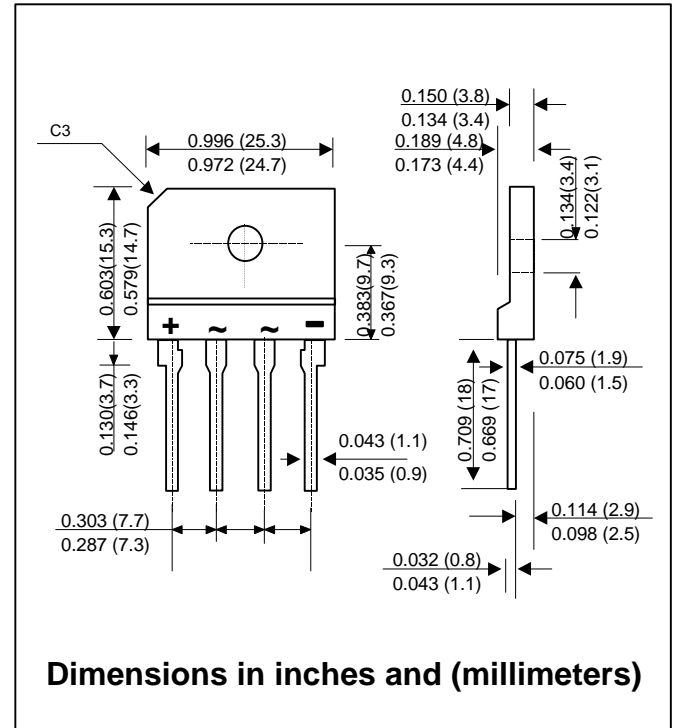

MAXIMUM RATINGS AND ELECTRICAL CHARACTERISTICS

Rating at 25 °C ambient temperature unless otherwise specified.
 Single phase, half wave, 60 Hz, resistive or inductive load.
 For capacitive load, derate current by 20%.

RATING	SYMBOL	D3SBA 10	D3SBA 20	D3SBA 40	D3SBA 60	D3SBA 80	UNIT
Maximum Reverse Voltage	V _{RM}	100	200	400	600	800	V
Maximum Average Forward Current (50Hz Sine wave, R-load)	I _{F(AV)}	4 (With heatsink, T _c = 108°C) 2.3 (Without heatsink, T _a = 25°C)					A
Maximum Peak Forward Surge Current (50 Hz, Half-cycle, Sinwave, Single Shot)	I _{FSM}	80					A
Current Squared Time at 1ms ≤ t < 10 ms, T _c =25°C	I ² t	32					A ² S
Maximum Forward Voltage per Diode at I _F = 2.0 A.	V _F	1.05					V
Maximum DC Reverse Current, V _R =V _{RM} (Pulse measurement, Rating of per diode)	I _R	10					μA
Maximum Thermal Resistance, Junction to case	R _{θJC}	5.5 (With heatsink)					°C/W
Maximum Thermal Resistance, Junction to Ambient	R _{θJA}	30 (Without heatsink)					°C/W
Operating Junction Temperature Range	T _J	150					°C
Storage Temperature Range	T _{STG}	- 40 to + 150					°C

RATING AND CHARACTERISTIC CURVES (D3SBA10 ~ D3SBA80)

FIG.1 - DERATING CURVE FOR OUTPUT RECTIFIED CURRENT

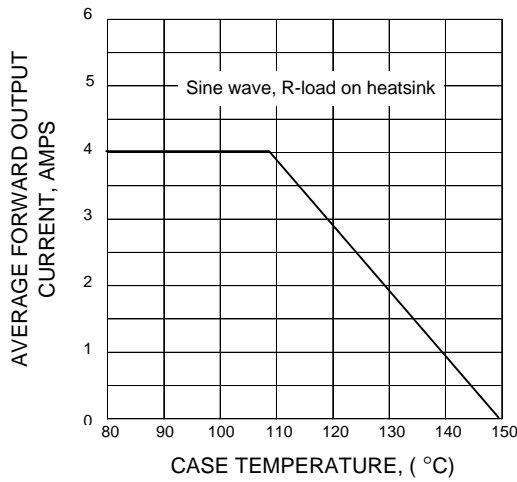

FIG.2 - MAXIMUM NON-REPETITIVE PEAK FORWARD SURGE CURRENT

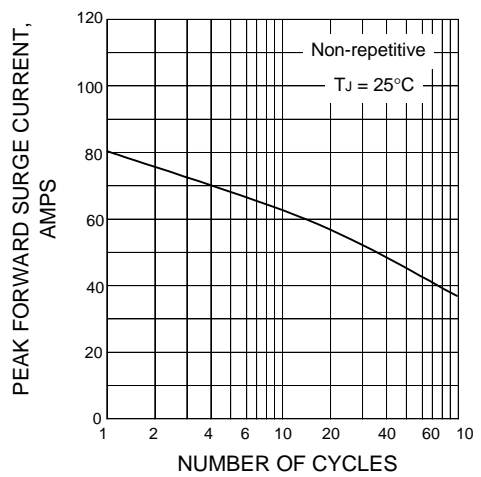

FIG.3 - TYPICAL FORWARD CHARACTERISTICS PER DIODE

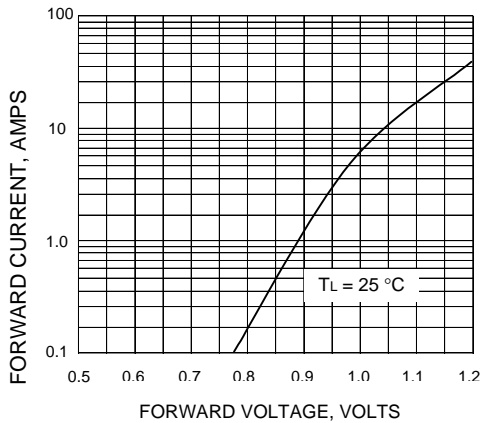

FIG.4 - POWER DISSIPATION

