

FEATURES:

- RAD-PAK® radiation-hardened against natural space radiation
- Total dose hardness:
 - > 100 krad (Si), depending upon space mission
- Output ports have equivalent 22-Ω series resistors, so no external resistors are required
- Support mixed-mode signal operation (5V input and output voltages with 3.3V V_{CC})
- Support unregulated battery operation down to 2.7V
- Typical V_{OLP} (Output ground bounce) < 0.8V at V_{CC} = 3.3V, T_A = 25°C
- I_{OFF} and power-up 3-state support hot insertion
- Bus hold on data inputs eliminates the need for external pull-up/pull-down resistors
- Distributed V_{CC} and GND pin configuration minimizes high-speed switching noise
- Flow-through architecture optimizes PCB layout
- Package: 48 pin RAD-PAK flat pack

DESCRIPTION:

Maxwell Technologies' 54LVTH162244 devices are 16-bit buffers and line drivers designed for low-voltage (3.3V) V_{CC} operation, but with the capability to provide a TTL interface to a 5V system environment. These devices can be used as four 4-bit buffers, two 8-bit buffers, or one 16-bit buffer. These devices provide true outputs and symmetrical active-low output-enable (OE) inputs.

The outputs, which are designed to source or sink up to 12 mA, include equivalent 22-Ω series resistors to reduce overshoot and undershoot. Active bus-hold circuitry is provided to hold unused or floating data inputs at a valid logic level.

Maxwell Technologies' patented RAD-PAK® packaging technology incorporates radiation shielding in the microcircuit package. It eliminates the need for box shielding while providing the required radiation shielding for a lifetime in orbit or space mission. In a GEO orbit, RAD-PAK provides greater than 100 krad (Si) radiation dose tolerance. This product is available with screening up to Class S.

TABLE 1. PINOUT DESCRIPTION

PIN	SYMBOL	DESCRIPTION
1, 48, 25, 24	$\overline{1OE-4OE}$	Output Enable
2, 3, 5, 6	1Y1-1Y4	Output
4, 10, 15, 21, 28, 34, 39, 45	GND	Ground
7, 18, 31, 42	V_{CC}	Supply Voltage
8, 9, 11, 12	2Y1-2Y4	Output
13, 14, 16, 17	3Y1-3Y4	Output
19, 20, 22, 23	4Y1-4Y4	Output
47, 46, 44, 43	1A1-1A4	Input
41, 40, 38, 37	2A1-2A4	Input
36, 35, 33, 32	3A1-3A4	Input
30, 29, 27, 26	4A1-4A4	Input

TABLE 2. 162244 ABSOLUTE MAXIMUM RATINGS ¹

PARAMETER	SYMBOL	MIN	MAX	UNIT
Supply Voltage Range	V_{CC}	-0.5	4.6	V
Input Voltage Range ²	V_I	-0.5	7	V
Voltage range applied to any output in the high-impedance or power-off state ²	V_O	-0.5	7	V
Voltage range applied to any output in the high state ²	V_O	-0.5 to V_{CC}	0.5	V
Current into any output in the low state	I_O	--	30	mA
Current into any output in the high state ³	I_O	30	--	mA
Input clamp current	$I_{IK} (V_I < 0)$	--	-50	mA
Output clamp current	$I_{OK} (V_O < 0)$	--	-50	mA
Operating Temperature	T_A	-55	125	°C
Storage Temperature Range	T_S	-65	150	°C
Operating Temperature Range	T_A	-55	125	°C

1. Stresses beyond listed under "absolute maximum ratings" may cause permanent damage to the device. These are stress ratings only and functional operation of the device at these or any other conditions beyond those indicated under "recommended operating conditions" is not implied. Exposure to absolute-maximum-rated conditions for extended periods may affect device reliability.
2. The input and output negative-voltage ratings may be exceeded if the input and output clamp-current ratings are observed.
3. This current flows only when the output is in the high state and $V_O > V_{CC}$.

TABLE 3. DELTA LIMITS

PARAMETER	VARIATION
$I_{CC(OP)}$	±10% of specified value on Table 5
I_{OZH}	±10% of specified value on Table 5
I_{OZL}	±10% of specified value on Table 5

TABLE 4. 162244 RECOMMENDED OPERATING CONDITIONS¹

PARAMETER	SYMBOL	MIN	MAX	UNIT
Supply Voltage	V_{CC}	2.7	3.6	V
High-level Input Voltage	V_{IH}	2	--	V
Low-level Input Voltage	V_{IL}	--	0.8	V
Input Voltage	V_I	--	5.5	V
High-level output current	I_{OH}	--	-12	mA
Low-level output current	I_{OL}	--	12	mA
Input Transition Rise or Fall Rate	Outputs enabled $\Delta t/\Delta v$	--	10	ns/V
Power-up ramp rate	$\Delta t/\Delta V_{CC}$	200	--	µs/V
Operating Temperature	T_A	-55	125	°C

1. All unused control inputs of the device must be held at high or low to ensure proper device operation.

TABLE 5. 162244 DC ELECTRICAL CHARACTERISTICS

($V_{CC} = 3.3V \pm 10\%$, $T_A = -55$ TO $+125^\circ C$, UNLESS OTHERWISE SPECIFIED)

PARAMETER	SYMBOL	TEST CONDITIONS		MIN	MAX	UNIT	
Input Clamp Voltage	V_{IK}	$V_{CC} = 2.7$	$I_I = -18mA$	--	-1.2	V	
High-Level Output Voltage	V_{OH}	$V_{CC} = 3V$	$I_{OH} = -12 mA$	2	--	V	
Low-Level Output Voltage	V_{OL}	$V_{CC} = 3V$	$I_{OL} = 12 mA$	--	0.8	V	
Input Current	I_I	$V_{CC} = 0$ or $3.6V$	$V_I = 5.5V$	--	10	µA	
		$V_{CC} = 3.6V$	$V_I = V_{CC}$ or GND	Control inputs	--		±1
		$V_{CC} = 3.6V$	$V_I = V_{CC}$	Data Inputs	--		1
Hold Current	$I_{I(HOLD)}$	$V_{CC} = 3V$	$V_I = 0.8V$	Data Inputs	75	--	µA
			$V_I = 2V$		-75	--	
Output Disabled Leakage Current - High	I_{OZH}	$V_{CC} = 3.6V, V_O = 3V$		--	5	µA	

TABLE 5. 162244 DC ELECTRICAL CHARACTERISTICS

 $(V_{CC} = 3.3V \pm 10\%, T_A = -55 \text{ TO } +125^\circ\text{C}, \text{ UNLESS OTHERWISE SPECIFIED})$

PARAMETER	SYMBOL	TEST CONDITIONS	MIN	MAX	UNIT	
Output Disabled Leakage Current - Low	I_{OZL}	$V_{CC} = 3.6V, V_O = 0.5V$	--	-5	μA	
Power Up Current	I_{OZPU}^2	$V_{CC} = 0 \text{ TO } 1.5V, V_O = 0.5V \text{ TO } 3V, \overline{OE} = \text{don't care}$	--	± 100	μA	
Power Down Current	I_{OZPD}^2	$V_{CC} = 1.5V \text{ TO } 0, V_O = 0.5V \text{ TO } 3V, \overline{OE} = \text{don't care}$	--	± 100	μA	
Supply Current	I_{CC}	$V_{CC} = 3.6V$	Outputs high	--	0.19	mA
		$I_O = 0$	Outputs low	--	5	
		$V_I = V_{CC} \text{ OR } \text{GND}$	Outputs disabled	--	0.19	
Delta Supply Current	ΔI_{CC}^1	$V_{CC} = 3V \text{ TO } 3.6V, \text{ One input at } V_{CC} - 0.6V, \text{ Other inputs at } V_{CC} \text{ OR } \text{GND}$	--	0.2	mA	
Input Capacitance	C_I^2	$V_I = 3V \text{ OR } 0$	--	8	pF	
Input Output Capacitance	C_O^2	$V_O = 3V \text{ OR } 0$	--	15	pF	

1. This is the increase in supply current for each input that is at the specified TTL voltage level rather than V_{CC} or GND.
2. Guaranteed by design.

TABLE 6. 162244 AC ELECTRICAL CHARACTERISTICS

 $(T_A = -55 \text{ TO } +125^\circ\text{C}, C_L = 50 \text{ pF}, \text{ UNLESS OTHERWISE SPECIFIED})$

PARAMETER	SYMBOL	$V_{CC} = 3.3V \pm V$		$V_{CC} = 2.7V$		UNIT
		MIN	MAX	MIN	MAX	
Propogation Delay Time A to Y	t_{PLH}	1.1	4.6	--	5.1	ns
	t_{PHL}	1.1	3.9	--	4.5	
Output Enable Time \overline{OE} to Y	t_{PZH}	1.1	5.4	--	6.7	ns
	t_{PZL}	1.3	4.9	--	6.1	
Output Disable Time \overline{OE} to Y	t_{PHZ}	1.6	5.9	--	6.5	ns
	t_{PLZ}	1	5.9	--	5.8	
Output Skew	$t_{sk(o)}$	--	--	--	--	ns

TABLE 7. FUNCTION TABLE
(EACH 4-BIT BUFFER)

INPUTS		OUTPUT
\overline{OE}	A	Y
L	H	H
L	L	L
H	X	Z

FIGURE 1. LOAD CIRCUIT FOR OUTPUTS

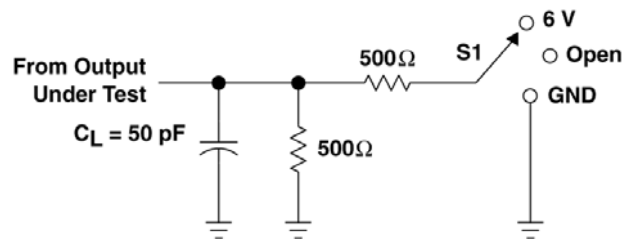

Figure Note:

1. C_L includes probe and jog capacitance

PARAMETER MEASUREMENT INFORMATION

TEST	S1
t_{PLH}/t_{PHL}	Open
t_{PLZ}/t_{PZL}	6V
t_{PHZ}/t_{PZH}	GND

FIGURE 2. PULSE DURATION

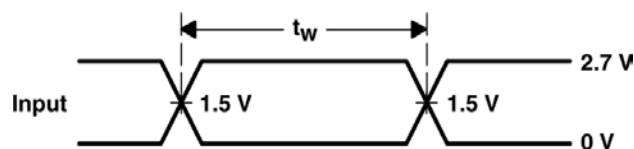

FIGURE 3. SETUP AND HOLD TIMES

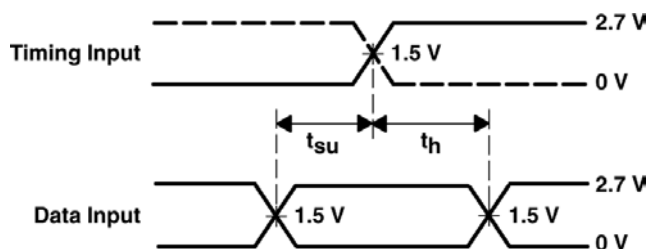

FIGURE 4. PROPAGATION DELAY TIMES INVERTING AND NON-INVERTING OUTPUTS

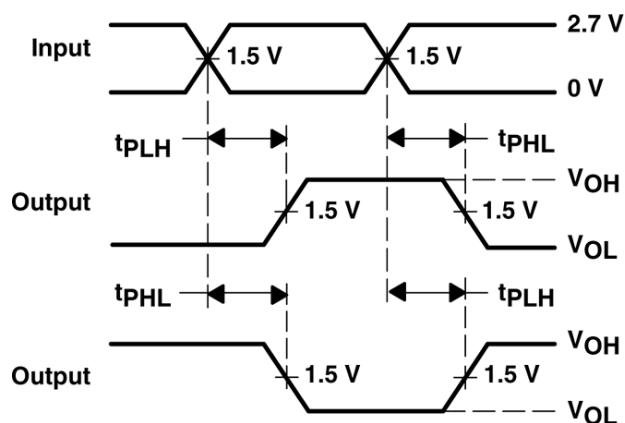

FIGURE 5. OUTPUT ENABLE TIMING

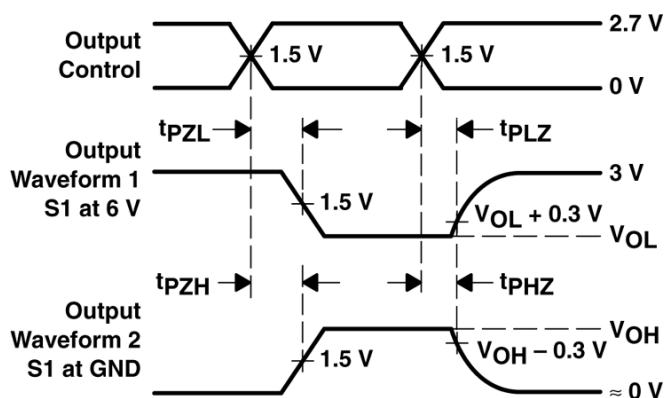
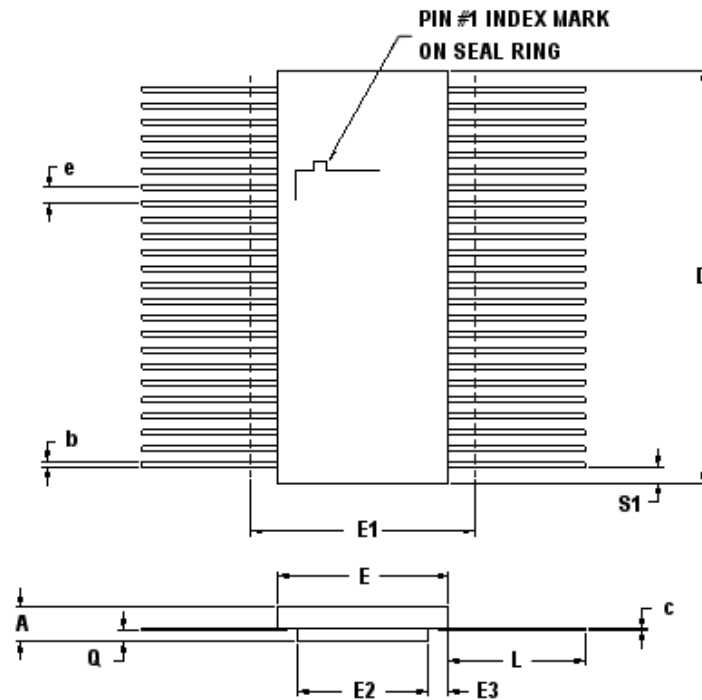

Figure Notes:

2. All input pulses are supplied by generators having the following characteristics: $PRR \leq 10 \text{ MHz}$, $Z_0 = 50 \Omega$, $t_r \leq 2.5 \text{ ns}$, $t_f \leq 2.5 \text{ ns}$.
3. Waveform 1 is for an output with internal conditions such that the output is low except when disabled by the output control. Waveform 2 is for an output with internal conditions such that the output is high except when disabled by the output control.
4. The outputs are measured one at a time with one transition per measurement.



48 PIN RAD-PAK® FLAT PACKAGE

SYMBOL	DIMENSION		
	MIN	NOM	MAX
A	0.121	0.130	0.139
b	0.008	0.010	0.014
c	0.004	0.006	0.006
D	--	0.620	0.640
E	0.370	0.380	0.390
E1	--	--	0.410
E2	0.200	0.210	0.220
E3	0.075	0.085	--
e	0.025 BSC		
L	0.275	0.285	0.295
Q	0.000	0.019	0.045
S1	0.005	0.018	--
N	48		

F48-01

Note: All dimensions in inches

Important Notice:

These data sheets are created using the chip manufacturer's published specifications. Maxwell Technologies verifies functionality by testing key parameters either by 100% testing, sample testing or characterization.

The specifications presented within these data sheets represent the latest and most accurate information available to date. However, these specifications are subject to change without notice and Maxwell Technologies assumes no responsibility for the use of this information.

Maxwell Technologies' products are not authorized for use as critical components in life support devices or systems without express written approval from Maxwell Technologies.

Any claim against Maxwell Technologies must be made within 90 days from the date of shipment from Maxwell Technologies. Maxwell Technologies' liability shall be limited to replacement of defective parts.