

The VP5311/VP5511 converts digital Y, Cr, Cb, data into analog NTSC/PAL composite video and S-video signals. The outputs are capable of driving doubly terminated 75 ohm loads with standard video levels.

The device accepts data inputs complying with CCIR Recommendation 601 and 656. The data is time multiplexed on an 8 bit bus at 27MHz and is formatted as Y, Cr, Y, Cb (i.e. 4:2:2). The video blanking and sync information from REC 656 is included in the data stream when the VP5311/VP5511 is working in slave mode.

The output pixel rate is 27MHz and the input pixel rate is half this frequency, i.e. 13.5MHz.

All necessary synchronisation signals are generated internally when the device is operating in master mode. In slave mode the device will lock to the TRS codes or the HS and VS inputs.

The rise and fall times of sync, burst envelope and video blanking are internally controlled to be within composite video specifications.

Three digital to analog converters (DACs) are used to convert the digital luminance, chrominance and composite data into true analog signals. An internally generated reference voltage provides the biasing for the DACs.

FEATURES

- Converts Y, Cr, Cb data to analog composite video and S-video
- Supports CCIR recommendations 601 and 656
- All digital video encoding
- Selectable master/slave mode for sync signals
- Switchable chrominance bandwidth
- Switchable pedestal with gain compensation
- SMPTE 170M NTSC or CCIR 624 PAL compatible outputs
- GENLOCK mode
- Line 21 Closed Caption encoding
- I²C bus serial microprocessor interface
- VP5311B supports Macrovision anti-taping format Rev. 6.1, in PAL and Rev. 7.01 in NTSC.

APPLICATIONS

- Digital Cable TV
- Digital Satellite TV
- Multi-media
- Video games
- Karaoke
- Digital VCRs

ORDERING INFORMATION

VP5311B/CG/GP1N
VP5511B/CG/GP1N

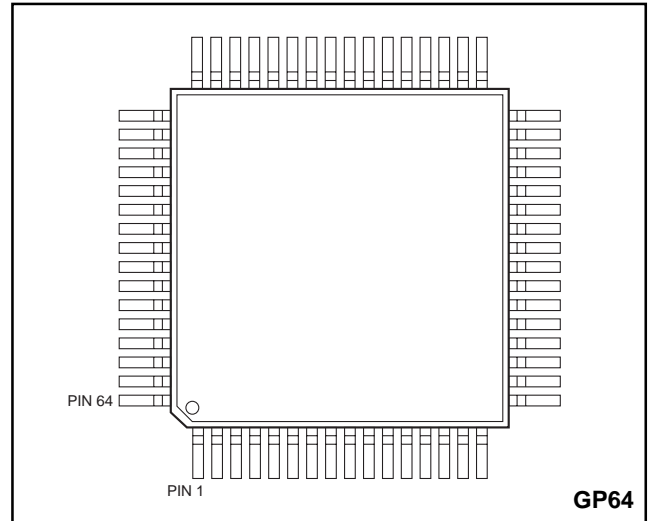

Figure 1 Pin connections (top view)

PIN	FUNCTION	PIN	FUNCTION
1	VDD	33	VDD
2	GND	34	RESET
3	D0 (VS I/O)	35	REFSQ
4	D1 (HS I/O)	36	GND
5	D2 (FC0 O/P)	37	VDD
6	D3 (FC1 O/P)	38	GND
7	D4 (FC2 O/P)	39	PD7
8	D5	40	PD6
9	D6 (SCSYN I/P)	41	PD5
10	D7 (PALID I/P)	42	PD4
11	GND	43	PD3
12	VDD	44	PD2
13	GND	45	PD1
14	GND	46	PD0
15	PXCK	47	GND
16	VDD	48	VDD
17	CLAMP	49	AGND
18	COMPSYNC	50	VREF
19	GND	51	DACGAIN
20	VDD	52	COMP
21	TDO	53	AVDD
22	TDI	54	LUMAOUT
23	TMS	55	AGND
24	TCK	56	COMPOUT
25	GND	57	AGND
26	SA1	58	CHROMAOUT
27	SA2	59	AVDD
28	SCL	60	N/C
29	VDD	61	N/C
30	SDA	62	AVDD
31	GND	63	AVDD
32	VDD	64	N/C

VP5311B/VP5511B

ELECTRICAL CHARACTERISTICS

Test conditions (unless otherwise stated): As specified in Recommended Operating Conditions

DC CHARACTERISTICS

Parameter	Conditions	Symbol	Min.	Typ.	Max.	Units
Digital Inputs TTL compatible (except SDA, SCL)						
Input high voltage		V _{IN}	2.0			V
Input low voltage		V _{IL}			0.8	V
Digital Inputs SDA, SCL						
Input high voltage		V _{IH}	0.7 V _{DD}			V
Input low voltage		V _{IL}			0.3 V _{DD}	V
Input high current	V _{IN} = V _{DD}	I _{IH}			10	μA
Input low current	V _{IN} = V _{SS}	I _{IL}			-10	μA
Digital Outputs CMOS compatible						
Output high voltage	I _{OH} = -1mA	V _{OH}	3.7			V
Output low voltage	I _{OL} = +4mA	V _{OL}			0.4	V
Digital Output SDA						
Output low voltage	I _{OL} = +6mA	V _{OL}			0.6	V

ELECTRICAL CHARACTERISTICS

Test conditions (unless otherwise stated): As specified in Recommended Operating Conditions

DC CHARACTERISTICS DACs

Parameter	Symbol	Min.	Typ.	Max.	Units
Accuracy (each DAC)					
Integral linearity error	INL			±1.5	LSB
Differential linearity error	DNL			±1	LSB
DAC matching error				±5	%
Monotonicity					
LSB size			66.83		μA
<small>guaranteed</small>			1.050		V
Internal reference voltage	V _{REF}		1.050		V
Internal reference voltage output impedance	Z _R		27k		Ω
Reference Current (V _{REF} /R _{REF}) R _{REF} = 769Ω	I _{REF}		1.3699		mA
DAC Gain Factor (V _{OUT} = K _{DAC} × I _{REF} × R _L), V _{OUT} = DAC code 511	K _{DAC}		24.93		
Peak Glitch Energy (see fig.3)			50		pV-s
CVBS, Y and C - NTSC (pedestal enabled)					
Maximum output, relative to sync bottom			33.75		mA
White level relative to black level			17.64		mA
Black level relative to blank level			1.40		mA
Blank level relative to sync level			7.62		mA
Colour burst peak - peak			7.62		mA
DC offset (bottom sync)			0.40		mA
CVBS, Y and C - PAL					
Maximum output			34.15		mA
White level relative to black level			18.71		mA
White level relative to sync level			26.73		mA
Black level relative to sync level			8.02		mA
Colour burst peak - peak			8.02		mA
DC offset (bottom sync)			0.00		mA

Note: All figures are for: R_{REF} = 769Ω R_L = 37.5Ω. When the device is set up in NTSC mode there is a +0.25% error in the PAL levels. If R_L = 75Ω then R_{REF} = 1538Ω.

ABSOLUTE MAXIMUM RATINGS

Supply voltage	V _{DD} , AV _{DD}	-0.3 to 7.0V
Voltage on any non power pin		-0.3 to V _{DD} +0.3V
Ambient operating temperature		0 to 70°C
Storage temperature		-55°C to 150°C

Note: Stresses exceeding these listed under Absolute Maximum Ratings may induce failure. Exposure to Absolute Maximum Ratings for extended periods may reduce reliability. Functionality at or above these conditions is not implied.

RECOMMENDED OPERATING CONDITIONS

Parameter	Symbol	Min.	Typ.	Max.	Units
Power supply voltage	VDD, AVDD	4.75	5.00	5.25	V
Power supply current (including analog outputs)	IDD		150		mA
Input clock frequency	PXCK	-50ppm	27.00	+50ppm	MHz
SCL clock frequency	f _{SCL}			500	kHz
Analog video output load			37.5		Ω
DAC gain resistor			769		Ω
Ambient operating temperature		0		70	°C

VIDEO CHARACTERISTICS

Parameter	Symbol	Min.	Typ.	Max.	Units
Luminance bandwidth			5.5		MHz
Chrominance bandwidth (Extended B/w mode)			1.3		MHz
Chrominance bandwidth (Reduced B/w mode)			650		kHz
Burst frequency (NTSC)			3.57954545		MHz
Burst frequency (PAL-B, D,G,H,I)			4.43361875		MHz
Burst frequency (PAL-N Argentina)			3.58205625		MHz
Burst cycles (NTSC)			9		Fsc cycles
Burst cycles (NTSC and PAL-B, D, G, H,I)			10		Fsc cycles
Burst envelope rise / fall time (NTSC and PAL-N)			300		ns
Burst envelope rise / fall time (NTSC and PAL-B, D, G, H,I)			300		ns
Analog video sync rise / fall time (NTSC and PAL-N)			145		ns
Analog video blank rise / fall time (NTSC and PAL-B, D, G, H,I)			245		ns
Differential gain			1.5		% pk-pk
Differential phase			0.5		° pk-pk
Signal to noise ratio (unmodulated ramp)			-61		dB
Chroma AM signal to noise ratio (100% red field)			-56	-61	dB
Chroma PM signal to noise ratio (100% red field)			-58	-56	dB
Hue accuracy				-58	%
Colour saturation accuracy				2.5	%
Residual sub carrier			-60	2.5	dB
Luminance / chrominance delay			10		ns

ESD COMPLIANCE

Pins	Test	Test Levels	Notes
All pins	Human body model	2kV on 100pF through 1k5Ω	Meets Mil-Std-883 Class 2
All pins	Machine model	200V on 200pF through 0Ω & 500nH	

VP5311B/VP5511B

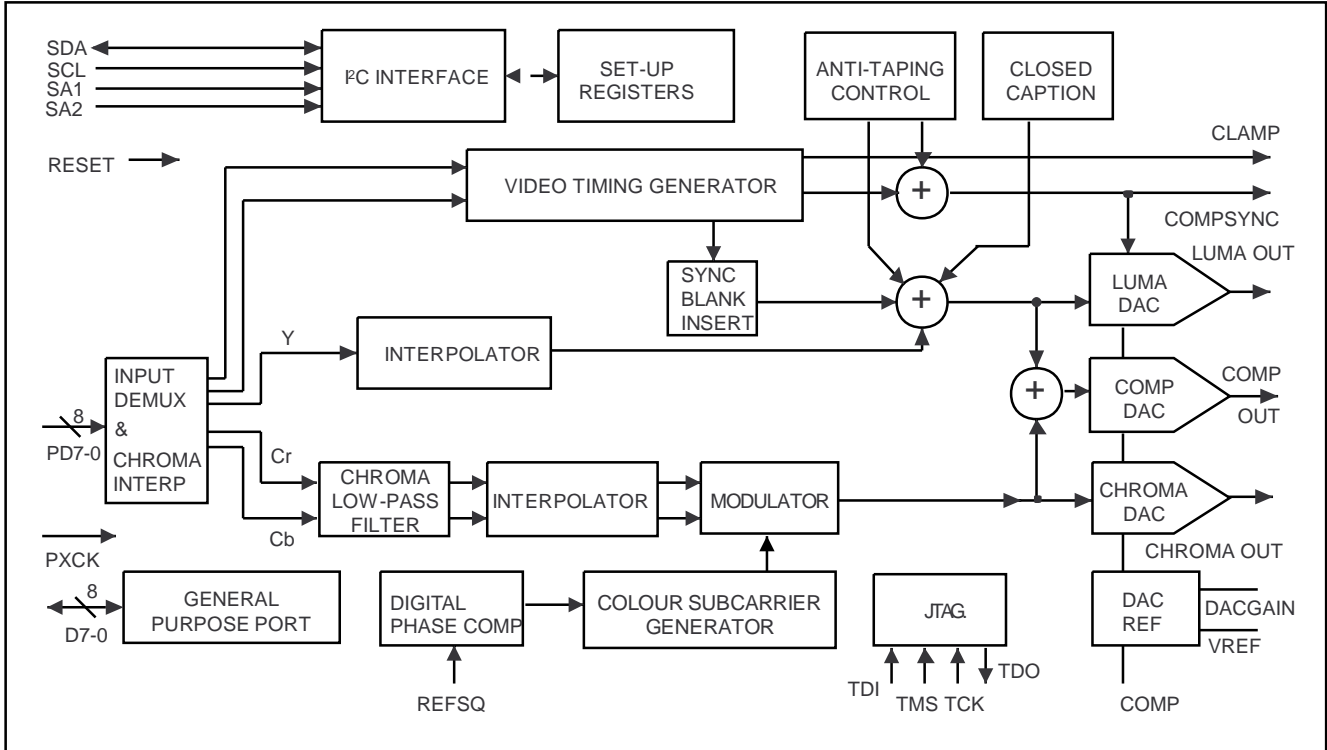

Figure 2 Functional block diagram of the VP5311B, the VP5511B is identical except there is no Anti-Taping Control

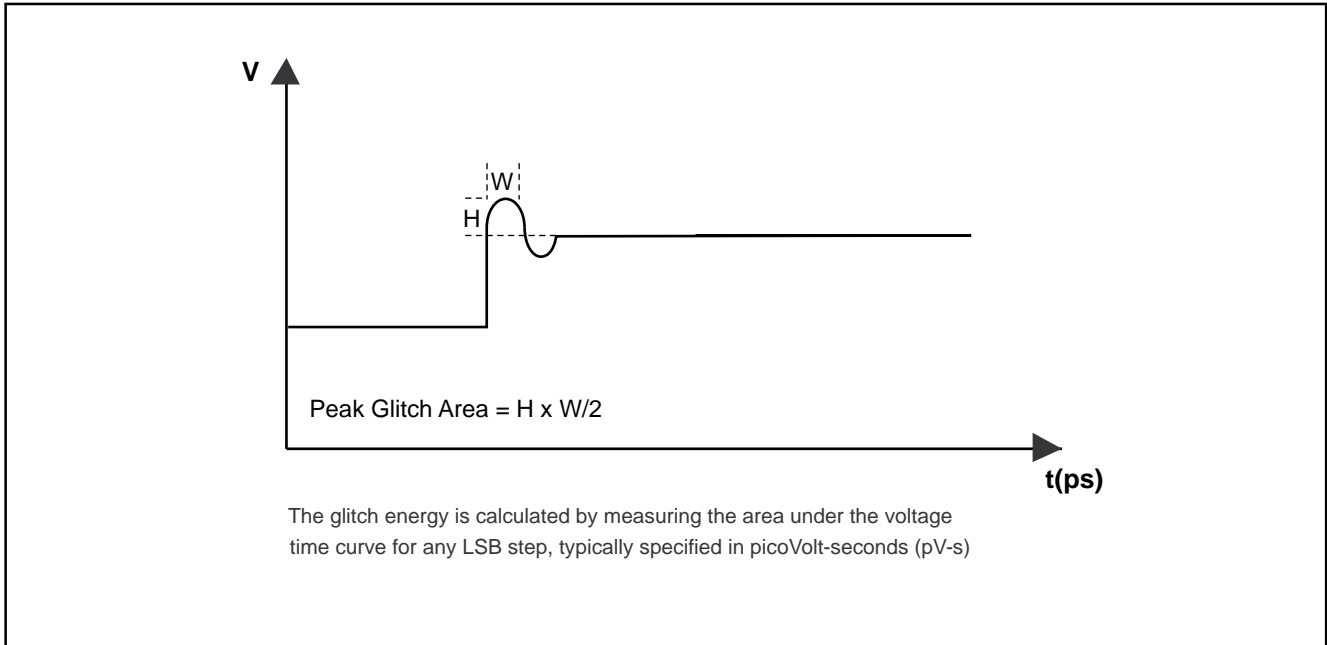

Figure 3 Glitch Energy

PIN DESCRIPTIONS

Pin Name	Pin No.	Description
PD0-7	39 - 46	8 Bit Pixel Data inputs clocked by PXCK. PD0 is the least significant bit, corresponding to Pin 46. These pins are internally pulled low.
D0-7	3 - 10	8 Bit General Purpose Port input/output. D0 is the least significant bit, corresponding to Pin 3. These pins are internally pulled low.
PXCK	15	27MHz Pixel Clock input. The VP5311 internally divides PXCK by two to provide the pixel clock.
CLAMP	17	The CLAMP output signal is synchronised to COMPSYNC output and indicates the position of the BURST pulse, (lines 10-263 and 273-525 for NTSC; lines 6-310 and 319-623 for PAL-B,D, G,I,N(Argentina)).
COMPSYNC	18	Composite sync pulse output. This is an active low output signal.
TDO	21	JTAG Data scan output port.
TDI	22	JTAG Data scan input port.
TMS	23	JTAG Scan select input.
TCK	24	JTAG Scan clock input.
SA1	26	Slave address select.
SA2	27	Slave address select.
SCL	28	Standard I ² C bus serial clock input.
SDA	30	Standard I ² C bus serial data input/output.
$\overline{\text{RESET}}$	34	Master reset. This is an asynchronous, active low, input signal and must be asserted for a minimum 200ns in order to reset the VP5311.
REFSQ	35	Reference square wave input used only during Genlock mode.
VREF	50	Voltage reference output. This output is nominally 1.055V and should be decoupled with a 100nF capacitor to GND.
DAC GAIN	51	DAC full scale current control. A resistor connected between this pin and GND sets the magnitude of the video output current. An internal loop amplifier controls a reference current flowing through this resistor so that the voltage across it is equal to the Vref voltage.
COMP	52	DAC compensation. A 100nF ceramic capacitor must be connected between pin 52 and pin 53.
LUMAOUT	54	True luminance, composite and chrominance video signal outputs. These are high impedance current source outputs. A DC path to GND must exist from each of these pins.
COMPOUT	56	
CHROMAOUT	58	
NOT USED	60, 61, 64	
VDD	1, 12, 16, 20, 29, 32, 33, 37, 48	Positive supply input. All VDD pins must be connected.
AVDD	53, 59 62, 63	Analog positive supply input. All AVDD pins must be connected.
GND	2, 11, 13, 14, 19, 25, 31, 36, 38, 47	Negative supply input. All GND pins must be connected.
AGND	49, 55, 57	Negative supply input. All AGND pins must be connected.

All other pins are N/C and should not be connected.

VP5311B/VP5511B

REGISTERS MAP

See Register Details for further explanations.

ADDRESS hex	REGISTER NAME	7	6	5	4	3	2	1	0	R/W	DEFAULT hex
	BAR	RA7	RA6	RA5	RA4	RA3	RA2	RA1	RA0	W	
00	PART ID2	ID17	ID16	ID15	ID14	ID13	ID12	ID11	ID10	R	13
01	PART ID1	ID0F	ID0E	ID0D	ID0C	ID0B	ID0A	ID09	ID08	R	66
02	PART ID0	ID07	ID06	ID05	ID04	ID03	ID02	ID01	ID00	R	58
03	REV ID	REV7	REV6	REV5	REV4	REV3	REV2	REV1	REV0	R	05
04	GCR	-	-	YCDELAY	RAMPEN	SLH&V	CVBSCLP	VFS1	VFS0	R/W	00
05	VOCR	-	CLAMPDIS	CHRBW	SYNCDIS	BURDIS	LUMDIS	CHRDIS	PEDEN	R/W	00
06	HANC	-	-	DFI2	DFI1	DFI0	Reserved	Reserved	ACTREN	*	00
07	ANCID	AN7	AN6	AN5	AN4	AN3	AN2	AN1	PARITY	R/W	00
08	SC_ADJ	SC7	SC6	SC5	SC4	SC3	SC2	SC1	SC0	R/W	9C
09	FREQ2	FR17	FR16	FR15	FR14	FR13	FR12	FR11	FR10	R/W	87
0A	FREQ1	FR0F	FR0E	FR0D	FR0C	FR0B	FR0A	FR09	FR08	R/W	C1
0B	FREQ0	FR07	FR06	FR05	FR04	FR03	FR02	FR01	FR00	R/W	F1
0C	SCHPHM	-	-	-	-	-	-	-	SCH8	R/W	00
0D	SCHPHL	SCH7	SCH6	SCH5	SCH4	SCH3	SCH2	SCH1	SCH0	R/W	00
0E to 1F	Reserved										
20	GPPCTL	CTL7	CTL6	CTL5	CTL4	CTL3	CTL2	CTL1	CTL0	W	FF
21	GPPRD	RD7	RD6	RD5	RD4	RD3	RD2	RD1	RD0	R	-
22	GPPWR	WR7	WR6	WR5	WR4	WR3	WR2	WR1	WR0	W	00
23 to EF	Not used										
F0	CCREG1	-	F1W1D6	F1W1D5	F1W1D4	F1W1D3	F1W1D2	F1W1D1	F1W1D0	R/W	00
F1	CCREG2	-	F1W2D6	F1W2D5	F1W2D4	F1W2D3	F1W2D2	F1W2D1	F1W2D0	R/W	00
F2	CCREG3	-	F2W1D6	F2W1D5	F2W1D4	F2W1D3	F2W1D2	F2W1D1	F2W1D0	R/W	00
F3	CCREG4	-	F2W2D6	F2W2D5	F2W2D4	F2W2D3	F2W2D2	F2W2D1	F2W2D0	R/W	00
F4	CC_CTL	-	-	-	-	F2ST	F1ST	F2EN	F1EN	R/W	00
F0 to F7	Reserved										
F8	HSOFFL	HSOFF7	HSOFF6	HSOFF5	HSOFF4	HSOFF3	HSOFF2	HSOFF1	HSOFF0	R/W	7E
F9	HSOFFM	-	-	-	-	-	-	HSOFF9	HSOFF8	R/W	00
FB	SLAVE1	NCORSTD	VBITDIS	VSMODE	F_SWAP	SL_HS1	SL_HS0	HCNT9	HCNT8	R/W	00
FC	SLAVE2	HCNT7	HCNT6	HCNT5	HCNT4	HCNT3	HCNT2	HCNT1	HCNT0	R/W	00
FD	TEST1			REGISTER	RESERVED	FOR	TEST			R/W	
FE	TEST2			REGISTER	RESERVED	FOR	TEST			R/W	
FF	GPSCTL	FSC4SEL	GENDITH	GENLKEN	NOLOCK	PALIDEN	TSURST	CHRMCLIP	TRSEL	R/W	00

Table.1 Register map

NOTE * For register HANC, bits 3, 4 and 5 are read only. Bits 1 and 2 are reserved. N/A = not applicable. For register PART ID0 the VP551 value is AB

Standard	Lines/field	Field freq. Hz	Number of pixels/line at 27MHz	Horizontal freq. kHz. f _H	Subcarrier freq. kHz. f _{sc}	fsc/f _H	SC_ADJ register hex	FREQ2-0 registers hex
NTSC (default)	525	59.94	1716	15.734266	3.57954545	(455/2)	xx	87 C1 F1
PAL-B, G, H, I	625	50	1728	15.625000	4.43361875	(1135/4+1/625)	9C	A8 26 2B
PAL-N (Argentina)	625	50	1728	15.625000	3.58205625	(917/4+1/625)	57	87 DA 51

Table.2 Line, field and subcarrier standards and register settings

xx = don't care.

The calculation of the FREQ register value is according to the following formula:-

$$FREQ = 2^{26} \times f_{sc} / PXCK \text{ hex, where } PXCK = 27.00\text{MHz}$$

NTSC value is rounded UP from the decimal number. PAL-B, D, G, H, I and N (Argentina) are rounded DOWN. The SC_ADJ value is derived from the adjustment needed to be added after 8 fields to ensure accuracy of the Subcarrier frequency. Note the SC_ADJ value of 9C required for PAL-B, D, G, H, I, is different to the default state of the register.

In NTSC the NCO is reset at the end of every line, this can be disabled by setting the NCORSTD bit in SLAVE1, this allows the VP5311 to cope with line lengths that are not exactly as specified in REC656.

REGISTER DETAILS

BAR
RA7-0 **Base register**
Register address.

PART ID 2-0
ID17-00 **Part number**
Chip part identification (ID) number.

REV ID
REV7-0 **Revision number**
Chip revision ID number.

GCR
YCDELAY **Global Control**
Luma to Chroma delay.
High = 37ns luma delay, this may be used to compensate for group delay in external filters.
Low = normal operation (default).

RAMPEN Modulated ramp enable.
High = ramp output for differential phase and gain measurements. A 27MHz clock must be applied to PXCK pin.
Low = normal operation (default).

SL_HS_VS
CVBSCLMP 1 = Slave to HS and VS inputs
1 = Enables clamp on composite output, to prevent flattening of chroma peak throughs

VFS1-0 Video format select

VFS1	VFS0	
0	0	NTSC (default)
0	1	PAL-B, D, G,H,I,N(Argentina)
1	0	Reserved
1	1	Reserved

VOCR
CLAMPDIS **Video Output Control**
High = Clamp signal disable
Low = normal operation with clamp signal enabled (default).

CHRBW Chroma bandwidth select.
High = ±1.3MHz.
Low = ±650kHz (default)

SYNCDIS High = Sync disable (in composite video signal). COMPSYNC is not affected.
Low = normal operation with sync enabled (default).

BURDIS High = Chroma burst disable.
Low = normal operation, with burst enabled (default).

LUMDIS High = Luma input disable - force black level with synchronisation pulses maintained.
Low = normal operation, with Luma input enabled (default).

CHRDIS High = Chroma input disable - force monochrome.
Low = normal operation, with Chroma input enabled (default).

PEDEN High = Pedestal (set-up) enable a 7.5 IRE pedestal on lines 23-262 and 286-525. Valid for NTSC

HANC
DFI2-0(read only)ANCTREN **Horizontal Ancillary Data Control**
Digital Field Identification, 000=Field1 Ancillary timing reference enable. When High use FIELD COUNT from ancillary data stream. When low, data is ignored.

ANCID
AN7-1
ANO **Ancillary data ID**
Ancillary data ID
Parity bit (odd)
Only ancillary data in REC 656 data stream with the same ID as this byte will be decoded by the VP5311/VP5511 to produce H and V synchronisation and FIELD COUNT.

SC_ADJ
SC7-0 **Sub Carrier Adjust**
Sub carrier frequency seed value, see table 2.

FREQ2-0
FR17-00 **Sub carrier frequency**
24 bit Sub carrier frequency programmed via I²C bus, see table 2. FREQ2 is the most significant byte (MSB).

SCHPHM-L
SCH9-0 **Sub carrier phase offset**
9 bit Sub carrier phase relative to the 50% point of the leading edge of the horizontal part of composite sync. SCHPHM bit 0 is the MSB. The nominal value is zero. This register is used to compensate for delays external to the VP5311/VP5511.

GPPCTL
CTL7-0 **General purpose port control**
Each bit controls port direction
Low = output High = input

GPPRD
RD7-0 **General purpose port read data**
I²C bus read from general purpose port (only INPUTS defined in GPPCTL)

GPPWR
WR7-0 **General purpose port write data**
I²C bus write to general purpose port (only OUTPUTS defined in GPPCTL)

CCREG1
F1W1D6-0 **Closed Caption register 1**
Field one (line 21), first data byte

CCREG2
F1W2D6-0 **Closed Caption register 2**
Field one (line 21), second data byte

CCREG3
F2W2D6-0 **Closed Caption register 3**
Field two (line 284), first data byte

CCREG4
F2W2D6-0 **Closed Caption register 4**
Field two (line 284), second data byte

VP5311B/VP5511B

CCCTL F1ST	Closed Caption control register Field one (line 21) status High = data has been encoded Low = new data has been loaded to CCREG1-2
F2ST	Field two (line 284) status High = data has been encoded Low = new data has been loaded to CCREG3-4
F1EN	Closed Caption field one (line 21) High = enable Low = disable (default)
F2EN	Closed Caption field two (line 284) High = enable Low = disable (default)
HSOFFM-L HSOFF9-0	HS offset This is a 10 bit number which allows the user to offset the start of digital data input with reference to the pulse HS.
SLAVE1 NCORSTD	H & V Slave mode control register 1 = NCO Line Reset Disable (NTSC only)
VBITDIS	0 = Video blanked when Rec601 V bit set 1 = V bit is ignored
F_SWAP SL_HS1-0 HCNT9-8	The odd and even fields are swapped Selects pixel sample (1 to 4) As HCNT7-0 but MSBs
SLAVE2 HCNT7-0	H & V Slave position register Adjusts for delay at which pixel data occurs relative to HS
GPSCTL FSC4SEL	GPS Control When high, REFSQ = 4xFSC and GPP bit D6 is forced to become an input for a SCSYNC signal (high = reset), which provides a synchronous phase reset for FSC divider. Low = normal operation with REFSQ = 1xFSC. (default).
GENDITH	1 = Gen lock dither added.
GENLKEN	High = enable Genlock to REFSQ signal input. Low = internal subcarrier generation (default).
NOLOCK	Genlock status bit (read only) Low = Genlocked. High = cannot lock to REFSQ. This bit is cleared by reading and set again if lock cannot be attained.
PALIDEN	High = enable external PAL ID phase control and GPP bit D7 is forced to become an input for PAL ID switch signal, (GPP bit D7 - Low = +135°, High = -135°). Low = normal operation, internal PAL ID phase switch is used (default).

TSURST	High = chip soft reset. Registers are NOT reset to default values. Low = normal operation (default).
CHRMCLIP	High = enable clipping of chroma data when luma goes below black level and is clipped. Low = no chroma clipping (default).
TRSEL	High = master mode, GPP bits D0 - 4 are forced to become a video timing port with VS, HS and FIELD outputs. Low = slave mode, timing from REC656.

I²C BUS CONTROL INTERFACE

I²C bus address

A6	A5	A4	A3	A2	A1	A0	R/ \bar{W}
0	0	0	1	1	SA2	SA1	X

The serial microprocessor interface is via the bi-directional port consisting of a data (SDA) and a clock (SCL) line. It is compatible to the Philips I²C bus standard (Jan. 1992 publication number 9398 393 40011). The interface is a slave transmitter - receiver with a sub-address capability. All communication is controlled by the microprocessor. The SCL line is input only. The most significant bit (MSB) is sent first. Data must be stable during SCL high periods.

A bus free state is indicated by both SDA and SCL lines being high. START of transmission is indicated by SDA being pulled low while SCL is high. The end of transmission, referred to as a STOP, is indicated by SDA going from low to high while SCL is high. The STOP state can be omitted if a repeated START is sent after the acknowledge bit. The reading device acknowledges each byte by pulling the SDA line low on the ninth clock pulse, after which the SDA line is released to allow the transmitting device access to the bus.

The device address can be partially programmed by the setting of the pins SA1 and SA2. This allows the device to respond to one of four addresses, providing for system flexibility. The I²C bus address is seven bits long with the last bit indicating read / write for subsequent bytes.

The first data byte sent after the device address, is the sub-address - BAR (base address register). The next byte will be written to the register addressed by BAR and subsequent bytes to the succeeding registers. The BAR maintains its data after a STOP signal.

NTSC/PAL Video Standards

Both NTSC (4-field, 525 lines) and PAL (8-field, 625 lines) video standards are supported by the VP5311/VP5511. All raster synchronisation, colour sub-carrier and burst characteristics are adapted to the standard selected. The VP5311/VP5511 generates outputs which follow the requirements of SMPTE 170M and CCIR 624 for PAL signals.

The device supports the following:
NTSC,
PAL B, D, G, H, I, N (Argentina).

Video Blanking

The VP5311/VP5511 automatically performs standard composite video blanking. Lines 1-9, 264-272 inclusive, as well as the last half of line 263 are blanked in NTSC mode. In PAL mode, lines 1-5, 311-318, 624-625 inclusive, as well as the last half of line 623 are blanked.

The V bit within REC656 defines the video blanking when TRSEL (bit 0 of GPSCTL register) is set low. When in MASTER mode with TRSEL set high the video encoder is still enabled. Therefore if these lines are required to be blank they must have no video signal input.

Interpolator

The luminance and chrominance data are separately passed through interpolating filters to produce output sampling rates double that of the incoming pixel rate. This reduces the sinx/x distortion that is inherent in the digital to analog converters and also simplifies the analog reconstruction filter requirements.

Digital to Analog Converters

The VP5311/VP5511 contained three 9 bit digital to analog converters which produce the analog video signals. The DACs use a current steering architecture in which bit currents are routed to one of two outputs; thus the DAC has true and complementary outputs. The use of identical current sources and current steering their outputs means that monotonicity is guaranteed. An on-chip voltage reference of 1.050V provides the necessary biasing. However, the VP5311/VP5511 may be used in applications where an external 1V reference is provided on the VREF pin, to adjust the video levels. In this case, the external reference should be temperature compensated and provide a low impedance output.

The full-scale output currents of the DACs is set by an external 769Ω resistor between the DACGAIN and GND pins. An on-chip loop amplifier stabilises the full-scale output current against temperature and power supply variations.

The analog outputs of the VP5311/VP5511 are capable of directly driving doubly terminated 75Ω load then the DACGAIN resistor is simply doubled.

Luminance, Chrominance and Composite Video Outputs

The Luminance video output (LUMAOUT pin 54) drives a 37.5Ω load at 1.0V, sync tip to peak white. It contains only the luminance content of the image plus the composite sync pulses. In the NTSC mode, a set-up level offset can be added during the active video portion of the raster.

The Chrominance video output (CHROMAOUT pin 58) drives a 37.5Ω load at levels proportional in amplitude to the luma output (40 IRE pk-pk burst). This output has a fixed offset current which will produce approximately a 0.5V DC bias across the 37.5Ω load. Burst is injected with the appropriate timing relative to the luma signal.

The composite video output (COMPOUT pin 56) will also drive a 37.5Ω load at 1.0V, sync tip to peak white. It contains both the luminance and chrominance content of the signal plus the composite sync pulses.

The CVBS DAC output clipping feature limits the digital data going into the DAC so that if it goes outside the range it is limited to the maximum or minimum (511 or 000). This feature is permanently enabled.

CVBSCLP in register GCR. When set to a '1' this bit

enables an envelope prediction circuit that establishes if the chroma and luma added together is likely to go outside the CVBS DAC limits. If it is, then a smooth rounding of the chroma peaks is made to stop this happening. This prevents any high frequency components being produced as with the clipping function which will produce flat peaks. In practice there will be some loss of saturation in the colour.

Output sinx/x compensation filters are required on all video output, as shown in the typical application diagram, see figs. 8 & 9.

Video Timing - Slave sync mode

The VP5311/VP5511 has an internal timing generator which produces video timing signals appropriate to the mode of operation. In the default (power up) slave mode, all timing signals are derived from the input clock, PXCK, which must be derived from a crystal controlled oscillator. Input pixel data is latched on the rising edge of the PXCK clock.

The video timing generator produces the internal blanking and burst gate pulses, together with the composite sync output signal, using timing data (TRS codes) from the Ancillary data stream in the REC656 input signal, (when TRSEL (bit 0 of GPSCTL register) is set low).

HCNT

To ensure that the incoming data is sampled correctly a 10 bit binary number (HCNT) has to be programmed into the SLAVE1 and 2 registers. This will allow the device's internal horizontal counter to align with the video data, each bit represents one 13.5MHz cycle. To calculate this use the formula below:

NTSC

$$\text{HCNT} = \text{SN} + 119 \quad (\text{SN} = 0 - 738)$$

$$\text{HCNT} = \text{SN} + 739 \quad (\text{SN} = 739 - 857)$$

PAL

$$\text{HCNT} = \text{SN} + 127 \quad (\text{SN} = 0 - 738)$$

$$\text{HCNT} = \text{SN} + 737 \quad (\text{SN} = 737 - 863)$$

where SN is Rec. 656/601 sample number on which the negative edge of HSYNC occurs.

SL_HS

A further adjustment is also required to ensure that the correct Cr and Cb sample alignment. The bits SL_HS1-0 allows for four sampling positions in the CbYCrY sequence, failure to set this correctly will mean corruption of the colour or colour being interpreted as luma.

F_SWAP

If the field synchronisation is wrong it can be swapped by setting this bit.

V_SYNC

When set to a '1' this bit allows an odd/even square wave to provide the field synchronisation.

Example

NTSC

HSYNC occurs on Rec656 sample 721 (end of active video), then;

$$\text{HCNT} = 721 + 119 = 839 = 348 \text{ Hex}$$

$$\text{SL_HS} = 10 \text{ (for correct sample)}$$

to set slave mode send .04w08pzfbw48pzffw01

VP5311B/VP5511B

this sets registers as follows:

reg	04	fb	ff
data	08	0b	01

Note: HSOFF should always be zero when using slave mode.

Video Timing - Master sync mode

When TRSEL (bit 0 of GPSCTL register) is set high, the VP5311 operates in a MASTER sync mode, all REC656 timing reference codes are ignored and GPP bits D0 - 4 become a video timing port with VS, HS and FIELD outputs. The PXCK signal is, however, still used to generate all internal clocks. When TRSEL is set high, the direction setting of bits 4 - 0 of the GPPCTL register is ignored.

VS is the start of the field sync datum in the middle of the equalisation pulses. HS is the line sync which is used by the preceding MPEG2 decoder to define when to output digital video data to the VP5311. The position of the falling edge of HS relative to the first data Cb0, can be programmed in HSOFFM-L registers, see fig. 4.

HS offset

The position of the falling edge of HS relative to the first data Cb0, can be programmed in HSOFFM-L registers, see figure 4, this is called the pipeline delay and may need adjusting for a particular application. This is done by programming a 10 bit number called HSOFF into the HSOFFM and HSOFFL registers, HSOFFM being the most significant two bits and HSOFFL the least significant eight bits. A default value of 07EH is held in the registers.

The value to program into HSOFF can be looked up in tables 3 & 4:

Nck	HSOFF	Comment
0 to 120	126 to 6	HS normal (64 cks)
121 to 138	863 to 801	HS pulse shortened*
184 to 857	800 to 127	HS normal (64 cks)

Table.3 for NTSC

Nck	HSOFF	Comment
0 to 131	137 to 6	HS normal (64 cks)
132 to 194	869 to 807	HS pulse shortened*
195 to 863	806 to 138	HS normal (64 cks)

Table.4 for PAL-B, D, G, H, I, N

where Nck = number of 13.5MHz clock cycles between the falling edge of HS and Cb0 (first data I/P on PD7-0) see fig. 4. Decreasing HSOFF advances the HS pulse (numbers are in decimal).

*HS pulse shortened means that the width of the pulse will be less than the normal 64 13.5MHz clock cycles.

The interruption in the sequence of values is because the HS signal is jumping across a line boundary to the previous line as the offset is increased. The register default value is 7EH and this sets Nck to 0, ie. the HS negative edge and Cb0 are coincident in NTSC mode.

Genlock using REFSQ input

The VP5311 can be Genlocked to another video source by setting GENLKEN high (in GPSCTL register) and feeding a phase coherent sub carrier frequency signal into REFSQ. Under normal circumstances, REFSQ will be the same frequency as the sub carrier. But by setting FSC4SEL high (in GPSCTL register), a 4 x sub carrier frequency signal may be input to REFSQ. In this case, the Genlock circuit can be reset to the required phase of REFSQ, by supplying a pulse to SCSYNC (pin 9). The frequency of SCSYNC can be at sub carrier frequency, but once per line, or once per field could be adequate, depending on the application. When GENLKEN is set high, the direction setting of bit 6 in the GPPCTL register is ignored.

PALID Input

When in Genlock mode with GENLKEN set high (in GPSCTL register), the VP5311 requires a PAL phase identification signal, to define the correct phase on every line. This is supplied to PALID input (pin 10), High = -135° and low = +135°. The signal is asynchronous and should be changed before the sub carrier burst signal. PALID input is enabled by setting PALIDEN high (in GPSCTL register). When GENLKEN is high, the direction setting of bit 7 of the GPPCTL register is ignored

Master Reset

The VP5311/VP5511 must be initialised with the RESET pin 34. This is an asynchronous active low signal and must be active for a minimum of 200ns in order for the VP5311/VP5511 to be reset. The device resets to line 64, start of horizontal sync (i.e. line blanking active). There is no on-chip power on reset circuitry.

Line 21 coding

Two bytes of data are coded on the line 21 of each field, see figure 7. In the NTSC Closed Caption service, the default state is to code on line 21 of field one only. An additional service can also be provided using line 21 (284) of the second field. The data is coded as NRZ with odd parity, after a clock run-in and framing code. The clock run-in frequency = 0.5034965MHz which is related to the nominal line period, $D = H / 32$.

$$D = 63.55555556 / 32\mu s$$

Two data bytes per field are loaded via I²C bus registers CCREG1-4. Each field can be independently enabled by programming the enable bits in the control register (CC_CTL). The data is cleared to zero in the Closed Caption shift registers after it has been encoded by the VP5311/VP5511. Two status bit are provided (in CC_CTL), which are set high when data is written to the registers and set low when the data has been encoded on the Luma signal. The data is cleared to zero in the Closed Caption shift registers after it has been encoded by the VP5311/VP5511. The next data bytes must be written to the registers when the status bit goes high, otherwise the Closed Caption data output will contain Null characters. If a transmission slot is missed (ie. no data received) the encoder will send Null characters. Null characters are invisible to a closed caption receiver. The MSB (bit 7) is the parity bit and is automatically added by the encoder.

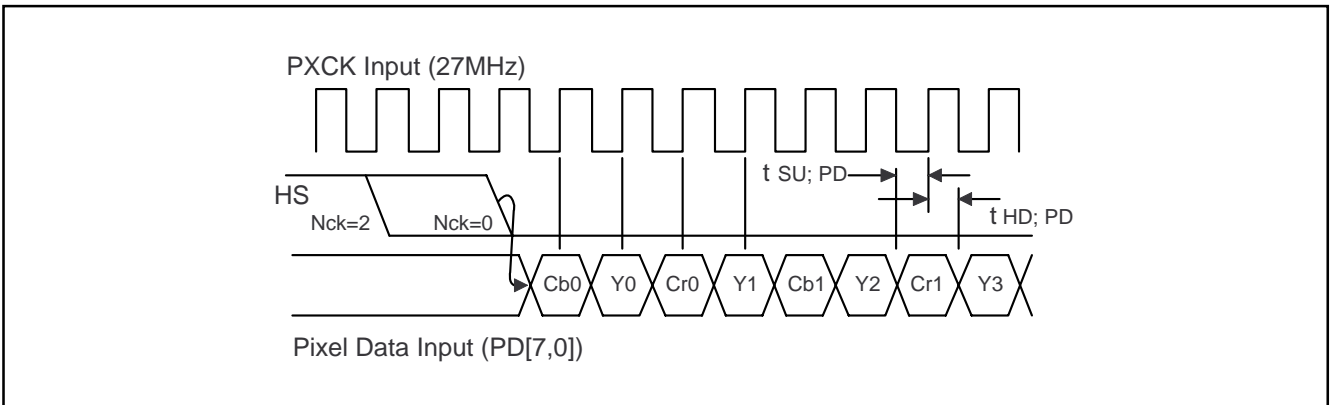

Figure 4 REC 656 interface with HS output timing

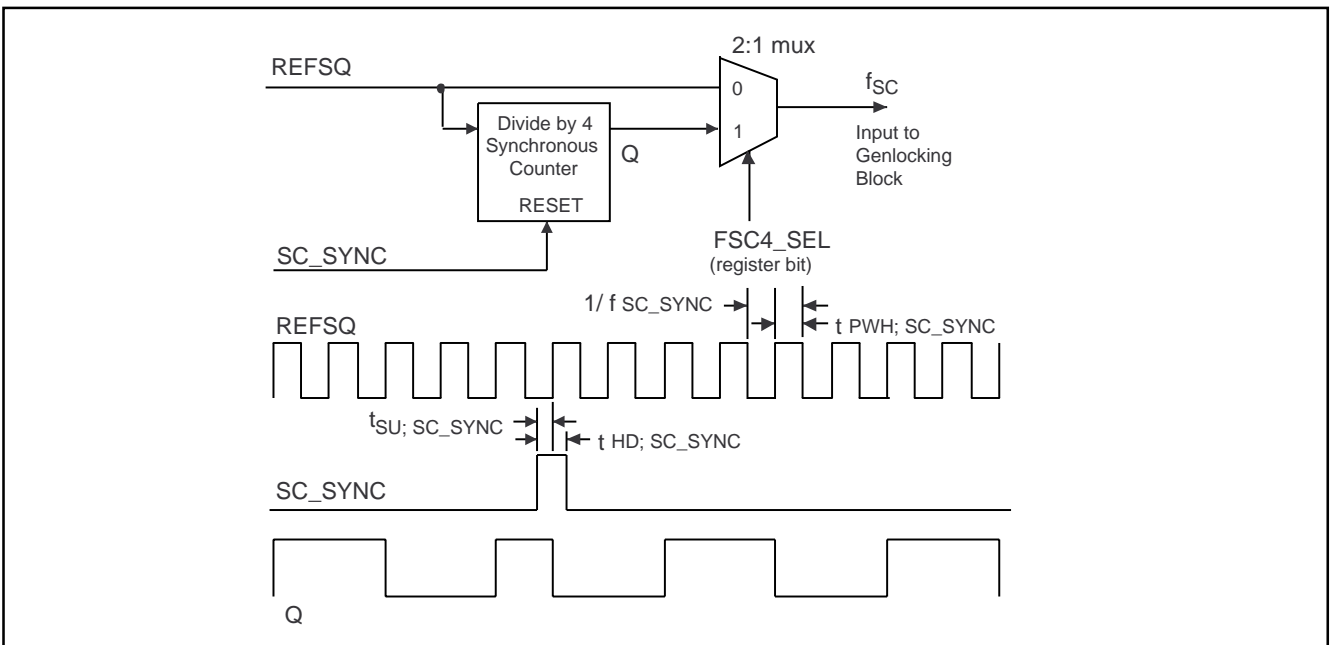

Figure 5 REFSQ and SC_SYNC input timing

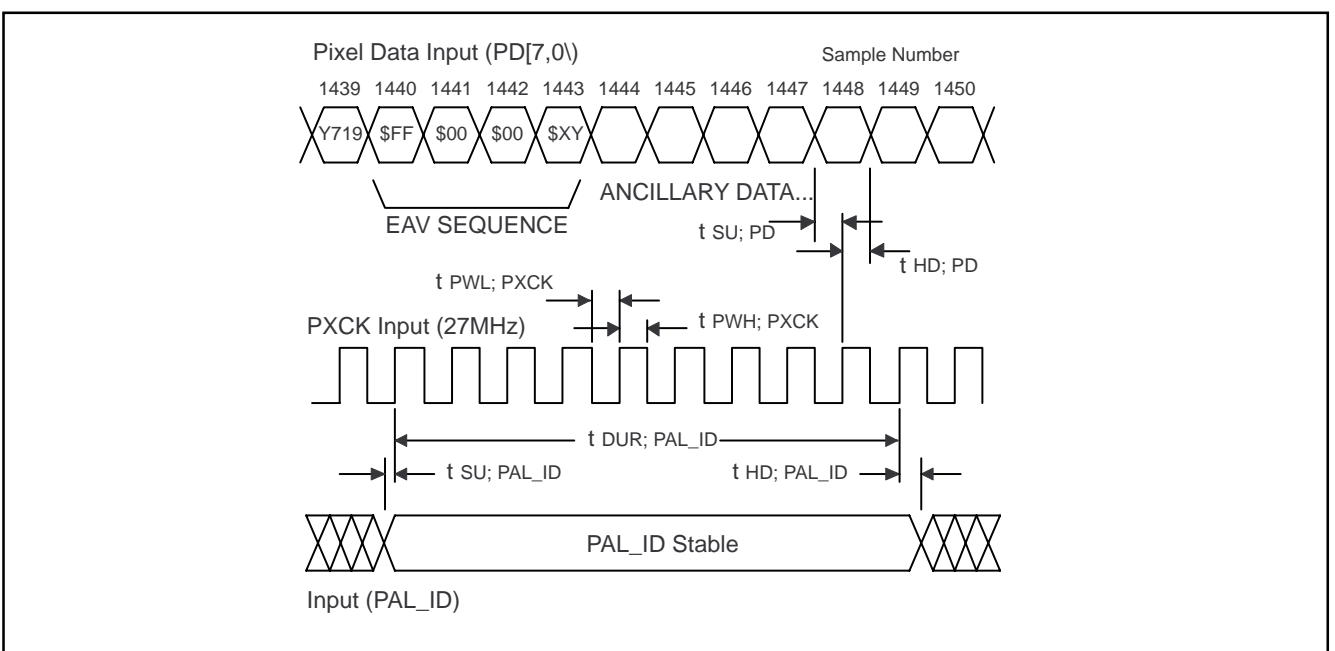

Figure 6 PAL_ID input timing

VP5311B/VP5511B

TIMING INFORMATION

Parameters	Conditions	Symbol	Min.	Typ.	Max.	Units
Master clock frequency (PXCK input)		f _{PXCK}		27.0		MHz
PXCX pulse width, HIGH		t _{PWH} ; PXCK	10			ns
PXCX pulse width, LOW		t _{PWL} ; PXCK	14.5			ns
PXCX rise time	10% to 90% points	t _{RP}			TBD	ns
PXCX fall time	90% to 10% points	t _{FP}			TBD	ns
PD7-0 set up time		t _{SU} ;PD	10			ns
PD7-0 hold time		t _{HD} ;PD	5			ns
SC_SYNC set up time		t _{SU} ;SC_SYNC	10			ns
SC_SYNC hold time		t _{HD} ;SC_SYNC	0			ns
PAL_ID set up time		t _{SU} ;PAL_ID	10			ns
PAL_ID hold time		t _{HD} ;PAL_ID	0			ns
PAL_ID duration		t _{DUR} ;PAL_ID	9			PXCX periods
Output delay	PXCK to COMPSYNC PXCK to CLAMP	t _{DOS}			25	ns

Note: Timing reference points are at the 50% level. Digital C_{LOAD} <40pF.

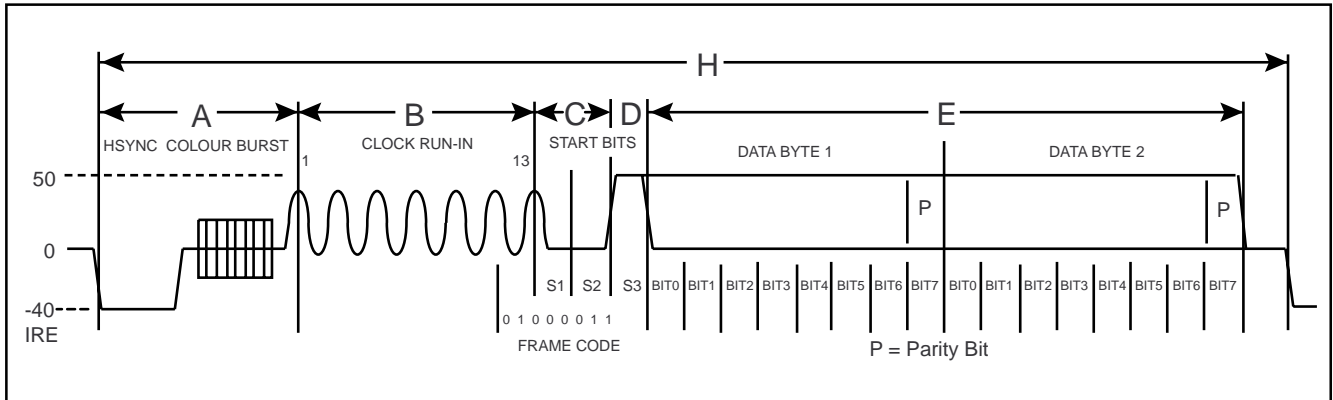

Figure 7 Closed Caption format

Interval	Description	Encoder minimum	Encoder nominal	Encoder maximum
A	H-sync to clock run-in	10.250 μ s	10.500 μ s	10.750 μ s
B	Clock run-in ^{2,3}		6.5D (12.910 μ s)	
C	Clock run-in to third start bit ³		2.0D (3.972 μ s)	
D	Data bit ^{1,3}		1.0D (1.986 μ s)	
E	Data characters ⁴		16.0D (31.778 μ s)	
H	Horizontal line ¹		32.0D (63.556)	
	Rise / fall time of data bit transitions ⁵		0.240 μ s	0.288 μ s
	Data bit high (logic level one) ⁶	48 IRE	50 IRE	52 IRE
	Clock run-in maximum			
	Data bit low (logic level zero) ⁶	0 IRE	0 IRE	2 IRE
	Clock run-in minimum			
	Data bit differential (high - low)	48 IRE	50 IRE	52 IRE
	Clock run-in differential (max. - min)			

Table 5 Closed Caption data timing. (source EIA R - 4.3 Sept 16 1992)

Notes

1. The Horizontal line frequency f_H is nominally 15734.26Hz \pm 0.05Hz. Interval D shall be adjusted to $D = 1/(f_H \times 32)$ for the instantaneous f_H at line 21.
2. The clock run-in signal consists of 7.0 cycles of a 0.5034965MHz (1/D) sine wave when measured from the leading to trailing 0 IRE points. The sine wave is to be symmetrical about the 25 IRE level.
3. The negative going midpoints (half amplitude) of the clock run-in shall be coherent with the midpoints (half amplitude) of the Start and Data bit transitions.
4. Two characters, each consisting of 7 data bits and 1 odd parity bit.
5. 2 T Bar, measured between the 10% and 90% amplitude points.
6. The clock run-in maximum level shall not differ from the data bit high level by more than ± 1 IRE. The clock run-in minimum level shall not differ from the data bit low level by more than ± 1 IRE.

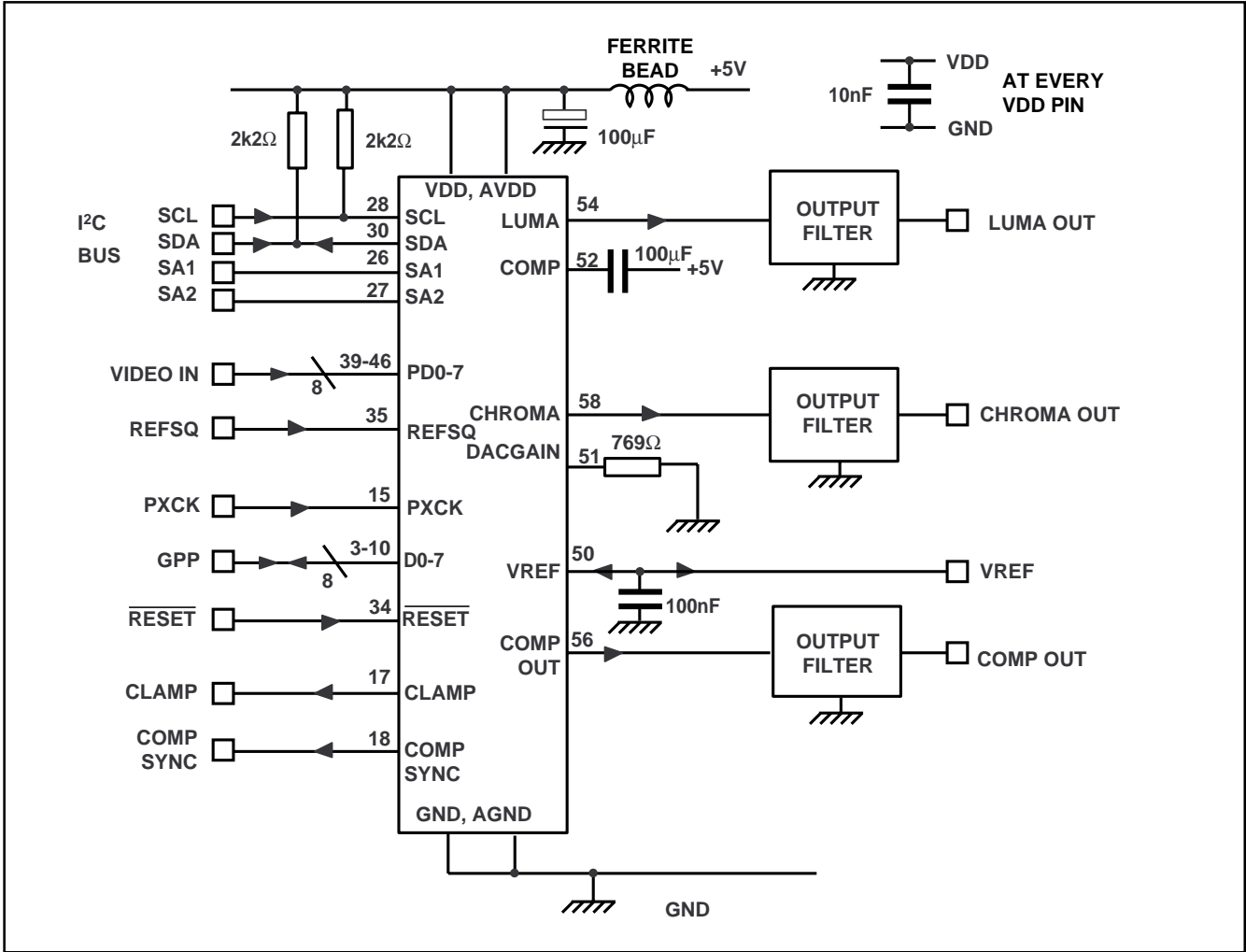

Figure 8 Typical application diagram, SLAVE mode. (Output filter - see Fig.9)

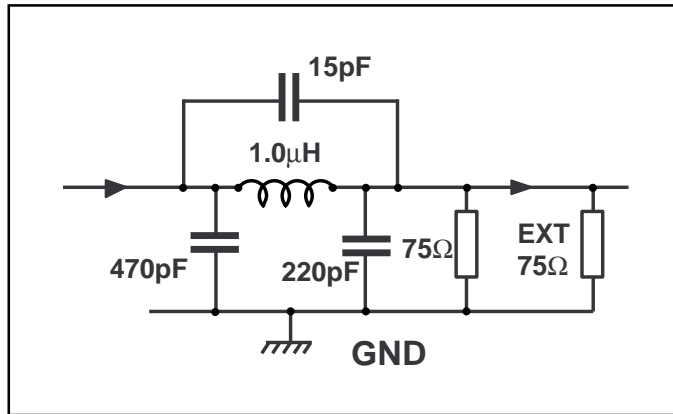
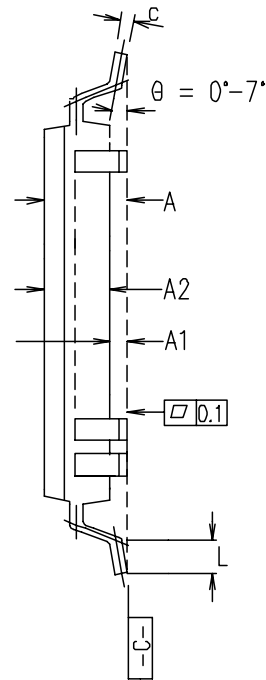
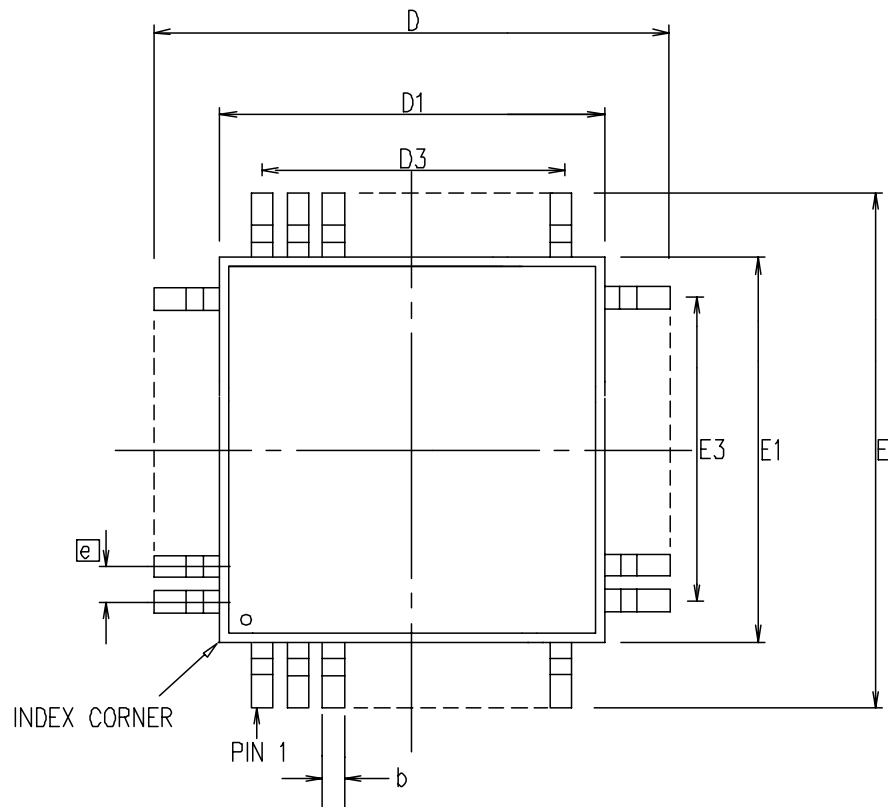

Figure 9 Output reconstruction filter

Note:

The VP5311 is only available to customers with a valid and existing authorisation to purchase issued by MACROVISION CORPORATION.

This device is protected by U.S. patent numbers 4631603, 4577216 and 4819098 and other intellectual property rights. Use of the Macrovision anticopy process in the device is licensed by Macrovision for non-commercial, home and limited exhibition uses only. Reverse engineering or disassembly is prohibited.



Symbol	Dimensions		
	MIN	Nominal	MAX
A			3.07
A1	0.25		
A2			2.82
D	16.95	17.20	17.45
D1	14.82	13.97	14.12
D3	11.90	12.00	12.10
E	16.95	17.20	17.45
E1	14.82	13.97	14.12
E3	11.90	12.00	12.10
L	0.60		1.40
e		0.80	BSC
B	0.30	0.35	0.40
C		0.15	
N	64		
ND	16		
NE	16		
NOTE	SQUARE		

Notes:

1. Pin 1 identification will be either a dot or a cutout.
2. All dimensions are in mm.
3. Applies to GG, GK and GC package types
4. Coplanarity at $[-C-]$ 0.15mm

This drawing supersedes 418/ED/5380/023 (Swindon)

© Mitel

ORIGINATING SITE: SWINDON

ISSUE	1				
ACN	203202				
DATE	200CT97				
APPROVED					

MITEL SEMICONDUCTOR

Title: OUTLINE DRAWING FOR
64 LEAD QUAD CERPAC (14 X 14 X 2.8)MM

Drawing Number

GPD00463

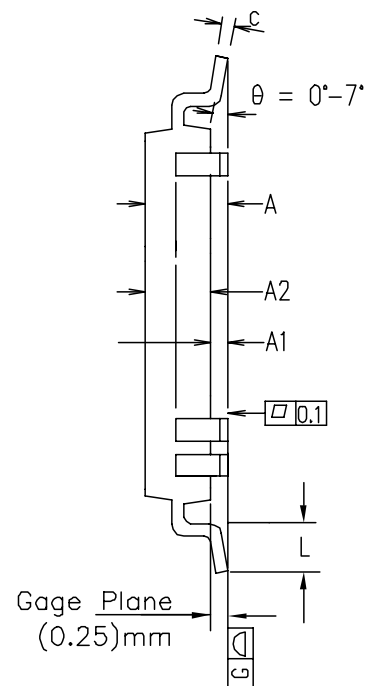
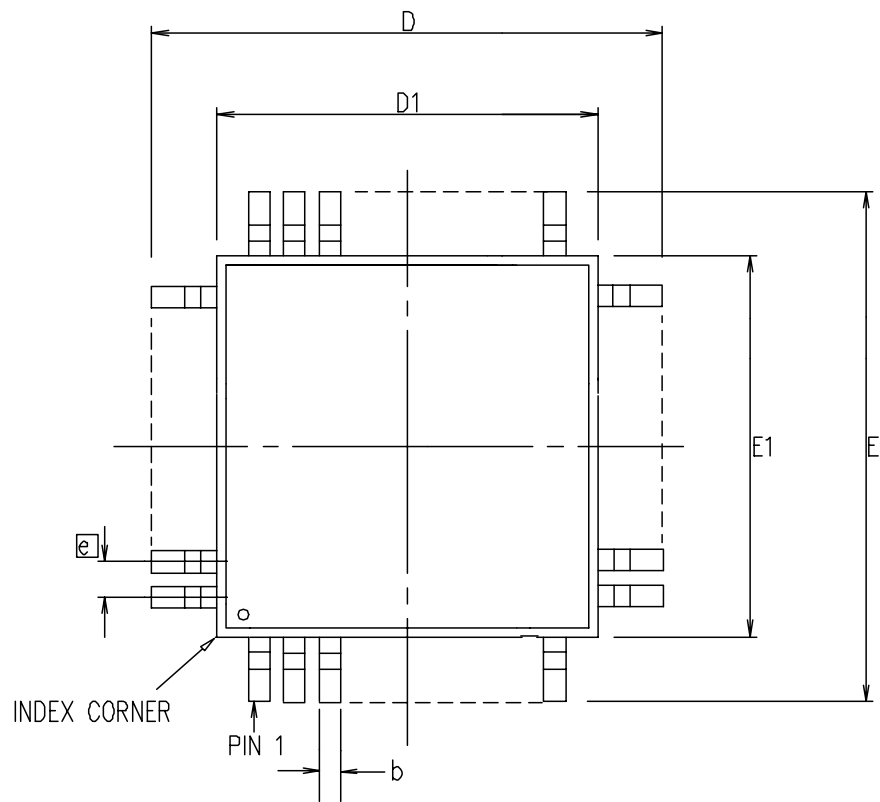

Symbol	Control Dimensions in millimetres		Altern. Dimensions in inches	
	MIN	MAX	MIN	MAX
A	—	2.45	—	0.096
A1	0.00	0.25	0.000	0.010
A2	1.80	2.20	0.071	0.087
D	17.20	BSC	0.677	BSC
D1	14.00	BSC	0.551	BSC
E	17.20	BSC	0.677	BSC
E1	14.00	BSC	0.551	BSC
L	0.73	1.03	0.029	0.041
e	0.80	BSC.	0.031	BSC.
b	0.29	0.45	0.011	0.018
c	0.11	0.23	0.004	0.009
Pin features				
N	64			
ND	16			
NE	16			
NOTE	SQUARE			

Conforms to JEDEC MS-022 BB Iss. B

Notes:

1. Pin 1 indicator may be a corner chamfer, dot or both.
2. Controlling dimensions are in millimeters.
3. The top package body size may be smaller than the bottom package body size by a max. of 0.15 mm.
4. Dimension D1 and E1 do not include mould protusion.
5. Dimension b does not include dambar protusion.
6. Coplanarity, measured at seating plane G, to be 0.010 mm max.

This drawing supersedes 418/ED/51210/029 (Swindon)

© Mitel 1999. All rights reserved.

ORIGINATING SITE: SWINDON

ISSUE	1	2	3	4
ACN	202049	204613	205110	207057
DATE	20FEB97	22MAY98	10SEP98	30JUN99
APPD.				

MITEL SEMICONDUCTOR

Title: Package Outline Drawing for
64L MQFP (GP)
(14x14x2.0) mm, Body+3.2 mm

Drawing Number

GPD00230

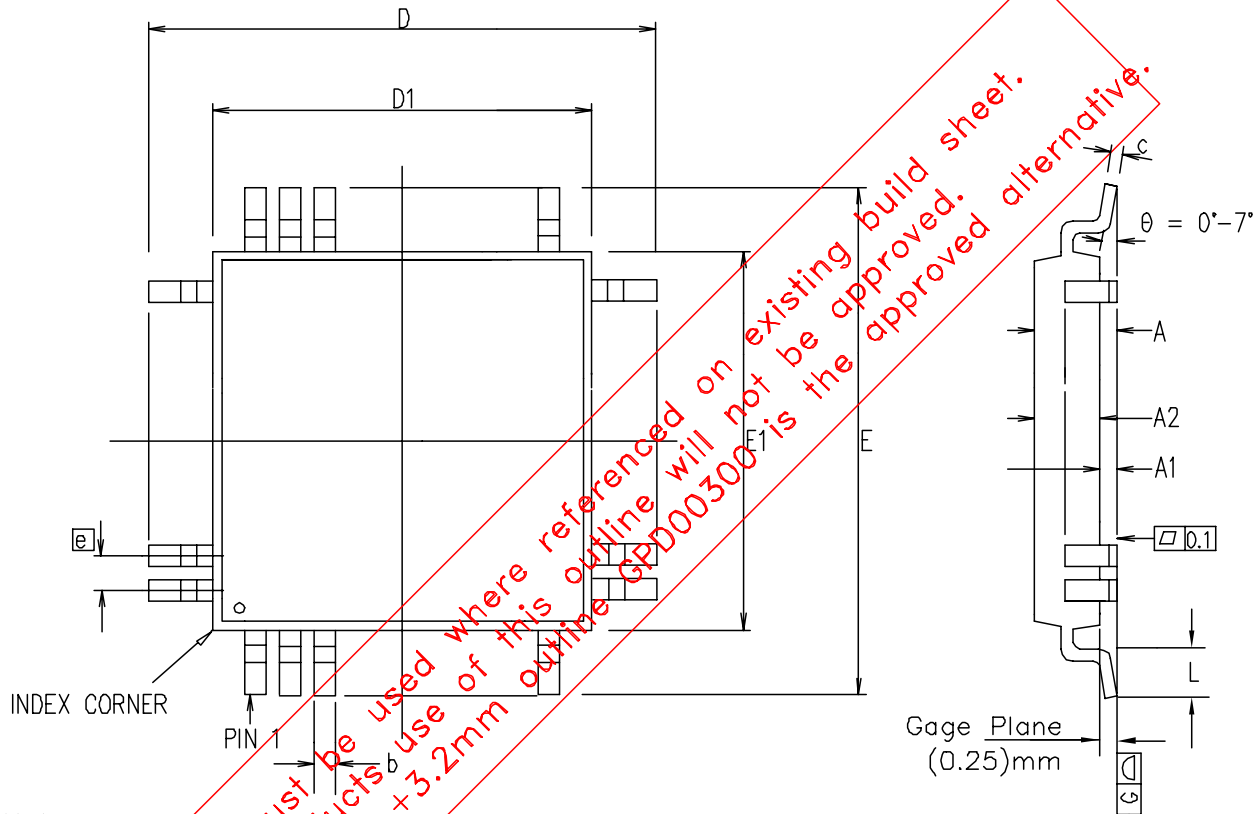

Symbol	Control Dimensions in millimetres		Altern. Dimensions in inches	
	MIN	MAX	MIN	MAX
A	—	2.45	—	0.096
A1	0.25	—	0.010	—
A2	1.95	2.10	0.077	0.083
D	13.90	BSC	0.547	BSC
D1	10.00	BSC	0.394	BSC
E	13.90	BSC	0.547	BSC
E1	10.00	BSC	0.394	BSC
L	0.73	1.03	0.029	0.041
e	0.65	BSC.	0.026	BSC.
b	0.22	0.38	0.009	0.015
c	0.11	0.23	0.004	0.009
Pin features				
N	52			
ND	13			
NE	13			
NOTE	SQUARE			

Conforms to JEDEC MO-112 AC-1 Iss. B

Notes:

1. Pin 1 indicator may be a corner chamfer, dot or both.
2. Controlling dimensions are in millimeters.
3. The top package body size may be smaller than the bottom package body size by a max. of 0.15 mm.
4. Dimension D1 and E1 do not include mould protusion.
5. Dimension b does not include dambar protusion.
6. Coplanarity, measured at seating plane G, to be 0.10 mm max.

This drawing supersedes 418/ED/51210/012 (Swindon) and TD/D856 (Oldham)

© Mitel 1999

ORIGINATING SITE: Swindon

ISSUE	1	2	3	4	5
ACN	201353	203135	203204	204756	207047
DATE	29OCT96	20CT97	21OCT97	23JUN98	29JUN99
APPROVED					

MITEL SEMICONDUCTOR

Title: Package Outline Drawing for
52L MQFP (GP)
(10x10x2.0) mm, Body+3.9 mm

Drawing Number

GPD00238



<http://www.mitelsemi.com>

World Headquarters - Canada

Tel: +1 (613) 592 2122
Fax: +1 (613) 592 6909

North America

Tel: +1 (770) 486 0194
Fax: +1 (770) 631 8213

Asia/Pacific

Tel: +65 333 6193
Fax: +65 333 6192

**Europe, Middle East,
and Africa (EMEA)**

Tel: +44 (0) 1793 518528
Fax: +44 (0) 1793 518581

Information relating to products and services furnished herein by Mitel Corporation or its subsidiaries (collectively "Mitel") is believed to be reliable. However, Mitel assumes no liability for errors that may appear in this publication, or for liability otherwise arising from the application or use of any such information, product or service or for any infringement of patents or other intellectual property rights owned by third parties which may result from such application or use. Neither the supply of such information or purchase of product or service conveys any license, either express or implied, under patents or other intellectual property rights owned by Mitel or licensed from third parties by Mitel, whatsoever. Purchasers of products are also hereby notified that the use of product in certain ways or in combination with Mitel, or non-Mitel furnished goods or services may infringe patents or other intellectual property rights owned by Mitel.

This publication is issued to provide information only and (unless agreed by Mitel in writing) may not be used, applied or reproduced for any purpose nor form part of any order or contract nor to be regarded as a representation relating to the products or services concerned. The products, their specifications, services and other information appearing in this publication are subject to change by Mitel without notice. No warranty or guarantee express or implied is made regarding the capability, performance or suitability of any product or service. Information concerning possible methods of use is provided as a guide only and does not constitute any guarantee that such methods of use will be satisfactory in a specific piece of equipment. It is the user's responsibility to fully determine the performance and suitability of any equipment using such information and to ensure that any publication or data used is up to date and has not been superseded. Manufacturing does not necessarily include testing of all functions or parameters. These products are not suitable for use in any medical products whose failure to perform may result in significant injury or death to the user. All products and materials are sold and services provided subject to Mitel's conditions of sale which are available on request.

M Mitel (design) and ST-BUS are registered trademarks of MITEL Corporation
Mitel Semiconductor is an ISO 9001 Registered Company
Copyright 1999 MITEL Corporation
All Rights Reserved
Printed in CANADA

TECHNICAL DOCUMENTATION - NOT FOR RESALE