

Silicon NPN Power Transistors

2SD2053

DESCRIPTION

- With TO-3PN package
- Wide area of safe operation
- Complement to type 2SB1362

APPLICATIONS

- For high power amplifier applications

PINNING

PIN	DESCRIPTION
1	Base
2	Collector;connected to mounting base
3	Emitter

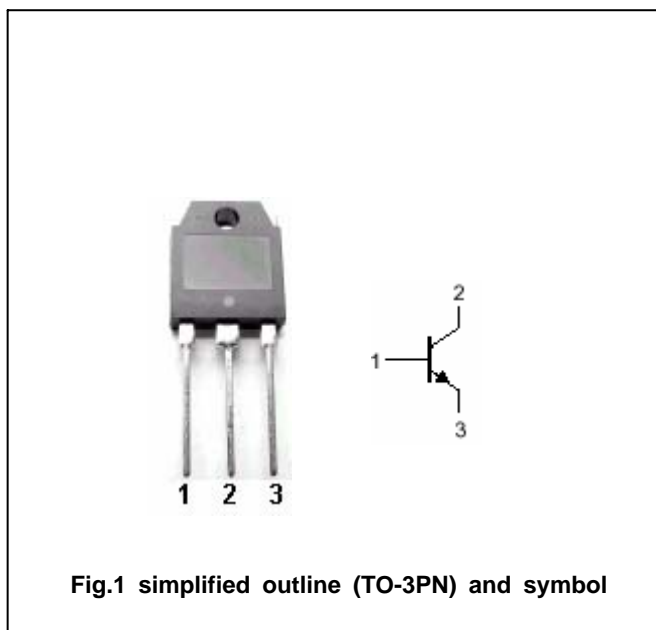

Fig.1 simplified outline (TO-3PN) and symbol

Absolute maximum ratings(Tc=25)

SYMBOL	PARAMETER	CONDITIONS	VALUE	UNIT
V_{CBO}	Collector-base voltage	Open emitter	150	V
V_{CEO}	Collector-emitter voltage	Open base	150	V
V_{EBO}	Emitter-base voltage	Open collector	5	V
I_C	Collector current (DC)		9	A
I_{CP}	Collector current (Pulse)		15	A
P_C	Collector power dissipation	$T_a=25$	2.5	W
		$T_C=25$	100	
T_j	Junction temperature		150	
T_{stg}	Storage temperature		-55~150	

Silicon NPN Power Transistors

2SD2053

CHARACTERISTICS

T_j=25 unless otherwise specified

SYMBOL	PARAMETER	CONDITIONS	MIN	TYP.	MAX	UNIT
V _{(BR)CEO}	Collector-emitter breakdown voltage	I _C =25mA; I _B =0	150			V
V _{CEsat}	Collector-emitter saturation voltage	I _C =7A; I _B =0.7A			2.0	V
V _{BE}	Base-emitter on voltage	I _C =7A; V _{CE} =5V			1.8	V
I _{CBO}	Collector cut-off current	V _{CB} =150V; I _E =0			50	μA
I _{EBO}	Emitter cut-off current	V _{EB} =5V; I _C =0			50	μA
h _{FE-1}	DC current gain	I _C =20mA; V _{CE} =5V	20			
h _{FE-2}	DC current gain	I _C =1A; V _{CE} =5V	60		200	
h _{FE-3}	DC current gain	I _C =7A; V _{CE} =5V	15			
f _T	Transition frequency	I _C =0.5A; V _{CE} =5V		20		MHz
C _{OB}	Collector output capacitance	f=1MHz; V _{CB} =10V		150		pF

◆ h_{FE-2} Classifications

Q	P
60-120	100-200

Silicon NPN Power Transistors

2SD2053

PACKAGE OUTLINE

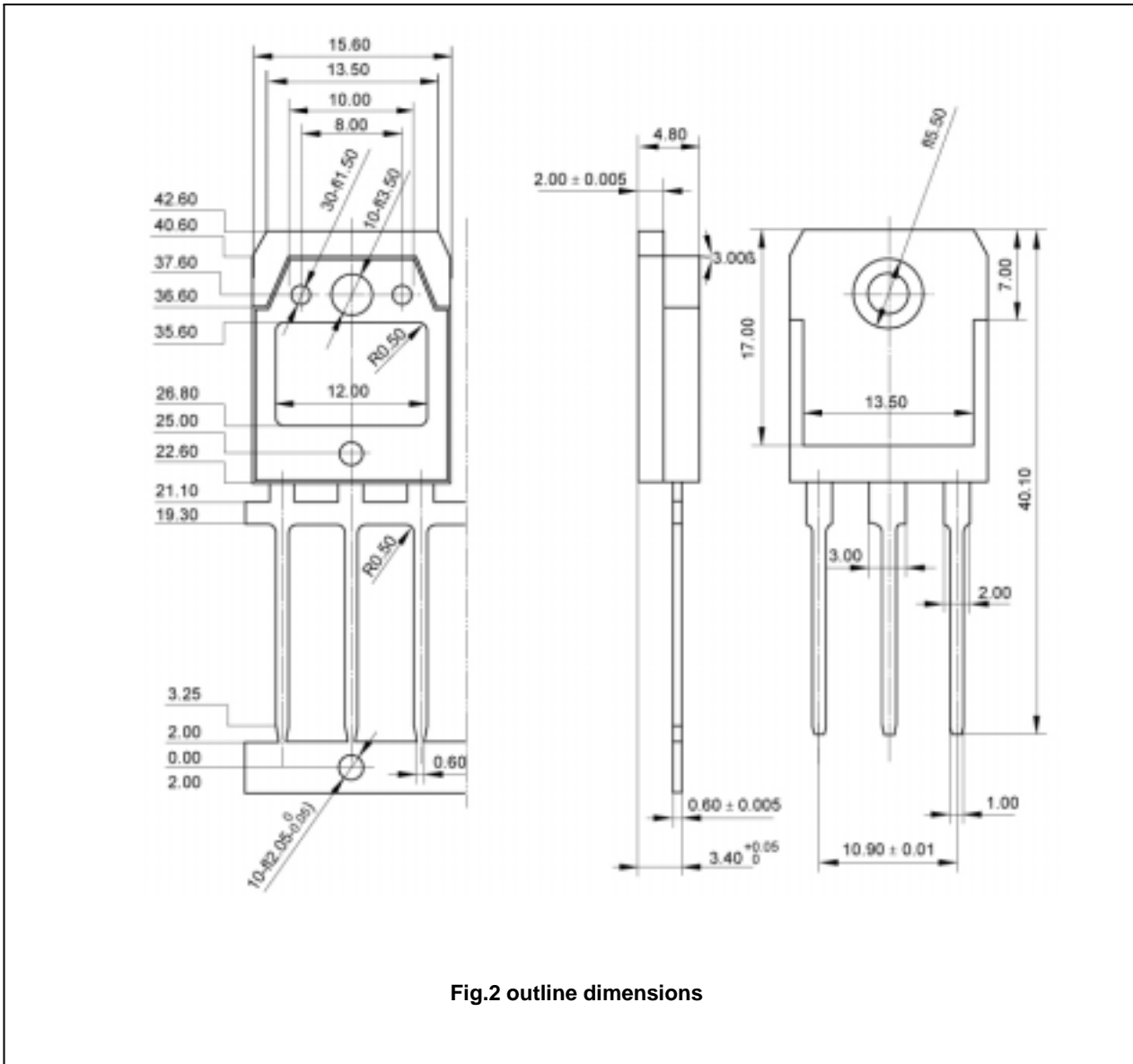

Fig.2 outline dimensions