

DESCRIPTION

The 12 Volt Combo chip is a combination spindle motor driver, voice coil driver and D/A converter. The part can be used in application like HDD.

The VCM amplifiers drive a low impedance coil and are set up to accept RC compensation, which allows a wide bandwidth with absolute minimum phase lag. The sense resistor/amplifier arrangement allows full current loop operation. The loop gain is changeable by attenuating the VCM DAC voltage amplitude in cascadable stages.

The Spindle driver is a PWM only voltage loop with power supply feedforward, driving a 3 phase sensorless brushless DC motor. Since it uses PWM operation at full run speed, it has output slew rate control during start and run modes. There is an inductive clamp circuit to limit flyback voltage transients across the supply voltage during motor phase changes and during the braking sequence. Only the 2 phase or bipolar commutation pattern is produced by the internal commutation circuitry. A commutation register allows arbi-

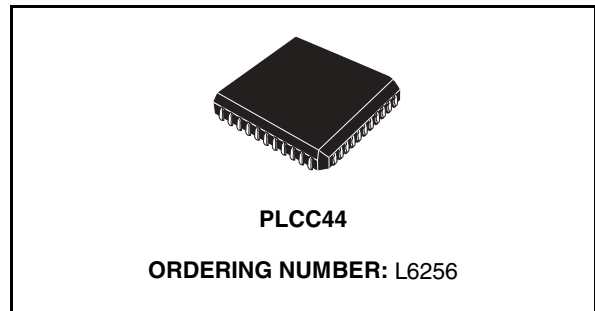

trary winding sequencing during certain operations. Internal protection against crossover spikes is built in.

3 phase or tripolar commutation can be supported in software during start by writing a commutation pattern directly to the preload register.

Tripolar operation requires that more than two phase drivers contribute current simultaneously. The current limit circuitry reflects this and allows 33% higher current limit, which produces nearly

Figure 1. Block Diagram

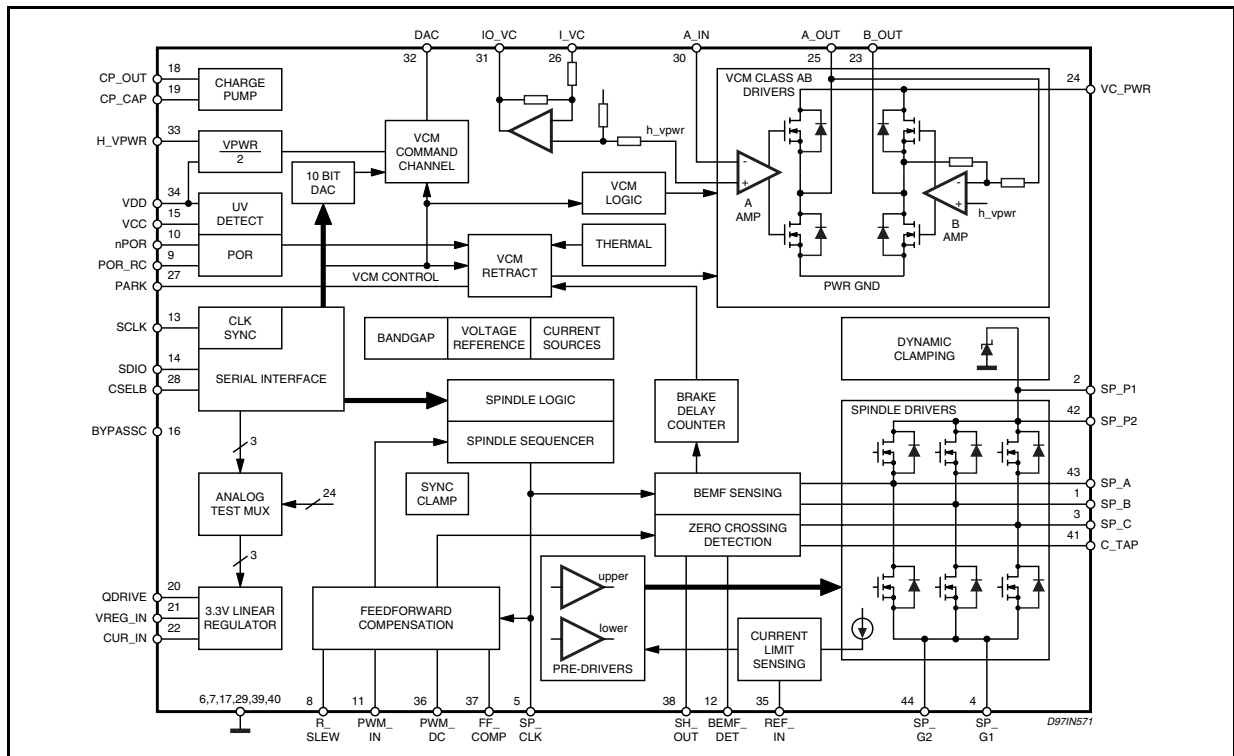

DESCRIPTION (Continued)

constant torque. This is a very high power dissipation mode, meant only for momentary operation in unusual circumstances.

Spindown during a power failure uses the back EMF voltage generated by the spindle motor to provide power to the VCM amplifier. The Spindle motor coasts during the Brake Delay time to allow time to park the head actuator. The park circuit is a constant voltage circuit settable externally.

After the head is parked, braking commences. The brake operates by shorting all 3 windings. The spindle output stages stay on as long as is

required to bring the motor to a complete stop, even if no power is applied to the part.

A Power On Reset (POR) function provides pulse stretching for the bidirectional POR\ bus, to ensure that the processor and clocks are at running speed before allowing them to function.

5 volt and 12 volt pins are used directly for the undervoltage detect circuit.

This allows direct use internally of both supplies. Voltage monitor margining is supported.

An external 3.3V linear regulator is provided and tied into the POR circuit.

OPERATING CONDITIONS

V_{CC} = 4.5 to 5.5V

V_{dd} = 10.8 to 13.2V

0°C < T_{amb} < 70°C.

ABSOLUTE MAXIMUM RATINGS

Symbol	Parameter	Value	Unit
V _{PWR}	Normal Operating Voltage	15	V
V _{PVR}	Inductive Clamp Voltage @ 2mH, 1.6A, 3% Duty Cycle	<20	V (1)
V _{dd}		15	V
V _{CC}		6.4	V
I _{VCM} , A _{out}		-2 to V _{PWR} +2V	
Logic I/O, SH_Out, PWM_DC		-0.3 to V _{CC} +0.3	
All other pins		-0.3 to V _{PWR} +0.3V	
T _{stg}	Storage Ambient Temperature	-65 to +150	°C
	ESD capability	±2	kV

(1) Limited by chip clamp voltage.

PIN CONNECTION

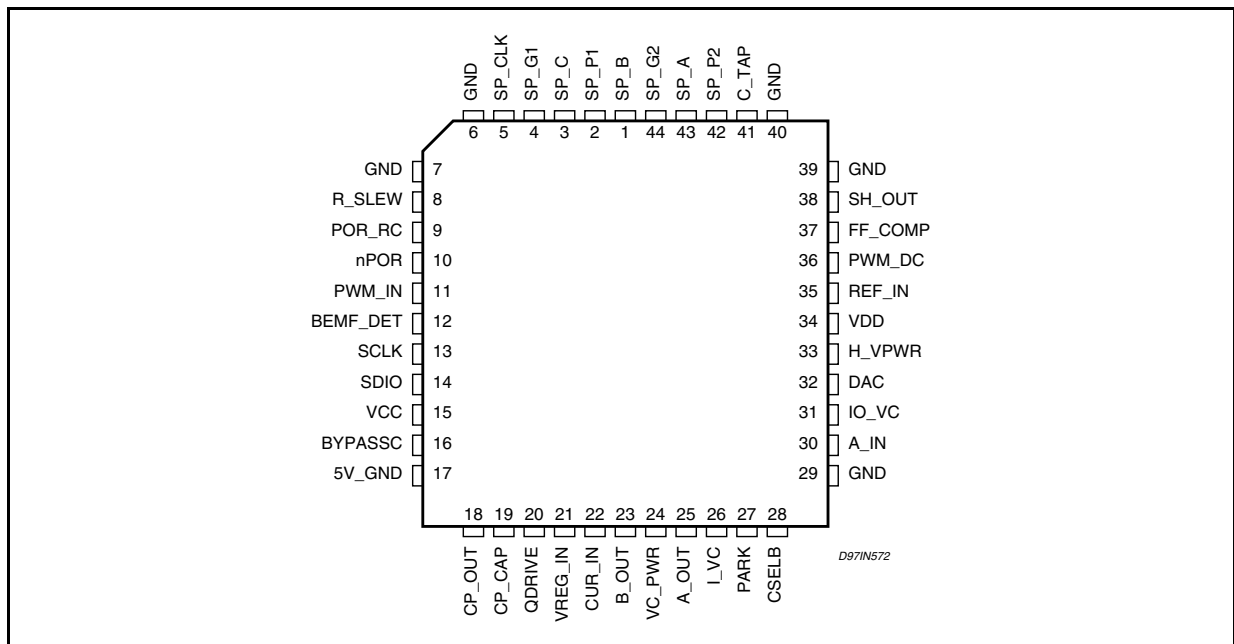

THERMAL DATA

Symbol	Description		Value	Unit
$R_{th\ j-pins}$	Thermal Resistance Junction-pins	Max.	12	°C/W
$R_{th\ j-amb}$	Thermal Resistance Junction-ambient (*)	Max.	50	°C/W

(*) Mounted on board with minimized dissipating copper area.

PIN DESCRIPTION

Pin #	Pin Name	Pin Description	Type
1	SP_B	Spindle Output, Ph B	Power/Output
2, 42	SP_P1, SP_P2	Spindle driver Supply	Power/Input
3	SP_C	Spindle Output, Ph C	Power/Output
4,44	SP_G1,SP_G2	Spindle Driver Ground	Power/Output
5	SP_CLK	Spindle Clock Input	Cmos/Input
6,7,29,39,40	GND	Power Ground	Ground/Heatsink
8	R_SLEW	Spindle Slew/FeedFwd Osc. Freq.	Analog/Input
9	POR_RC	Ext. POR Timing Cap.	Analog/Output
10	nPOR	POR Reset (Active LOW)	Cmos/BIO
11	PWM_IN	Spindle PWM Input	Cmos/Input
12	BEMF_DET	Spindle BEMF Output	Cmos/Output
13	SCLK	Serial Data Clock	Cmos/Input
14	SDIO	Bidirectional Serial Data I/O	Cmos/BIO
15	VCC	5V Digital Supply	Supply/Input
16	BYPASSC	Not to be used	-
17	5V_GND	5V Supply Ground	Ground/Output
18	CP_OUT	Charge Pump Pumping Cap	Analog/Output
19	CP_CAP	Charge Reservoir Cap	Analog/Input
20	QDRIVE	3.3V Regulator Base Drive	Analog/Output
21	VREG_IN	3.3V Regulator Voltage Feedback	Analog/IO
22	CUR_IN	3.3V Regulator Current Feedback	Analog/IO
23	B_OUT	VCM Driver Output, B	Power/Output
24	VC_PWR	VCM Drivers Supply	Power/Input
25	A_OUT	VCM Driver Output, A	Power/Output
26	I_VC	VCM Sense Amplifier Input	Analog/Input
27	PARK	VCM Park Pin	Analog/Input
28	CSELB	Chip Select	-
30	A_IN	VCM A-Amplifier Input	Analog/Input
31	IO_VC	VCM Sense Amplifier Output	Analog/Output
32	DAC	VCM DAC Command Output	Analog/Output
33	H_VPWR	VCM Vpwr/2 Reference Voltage	Analog/Output
34	VDD	12V Analog Supply	Supply/Input
35	REF_IN	Spindle Current Limit/Win Threshd	Analog/Input
36	PWM_DC	Spindle Filtered PWM Input	Analog/Input
37	FF_COMP	Spindle Feedforwd Ramp Generator	Analog/Input
38	SH_OUT	Spindle BEMF Sample/Hold	Analog/Output
41	C_TAP	Spindle Centre Tap	Analog/Input
43	SP_A	Spindle Output, Ph A	Power/Output

TYPICAL APPLICATION DIAGRAM

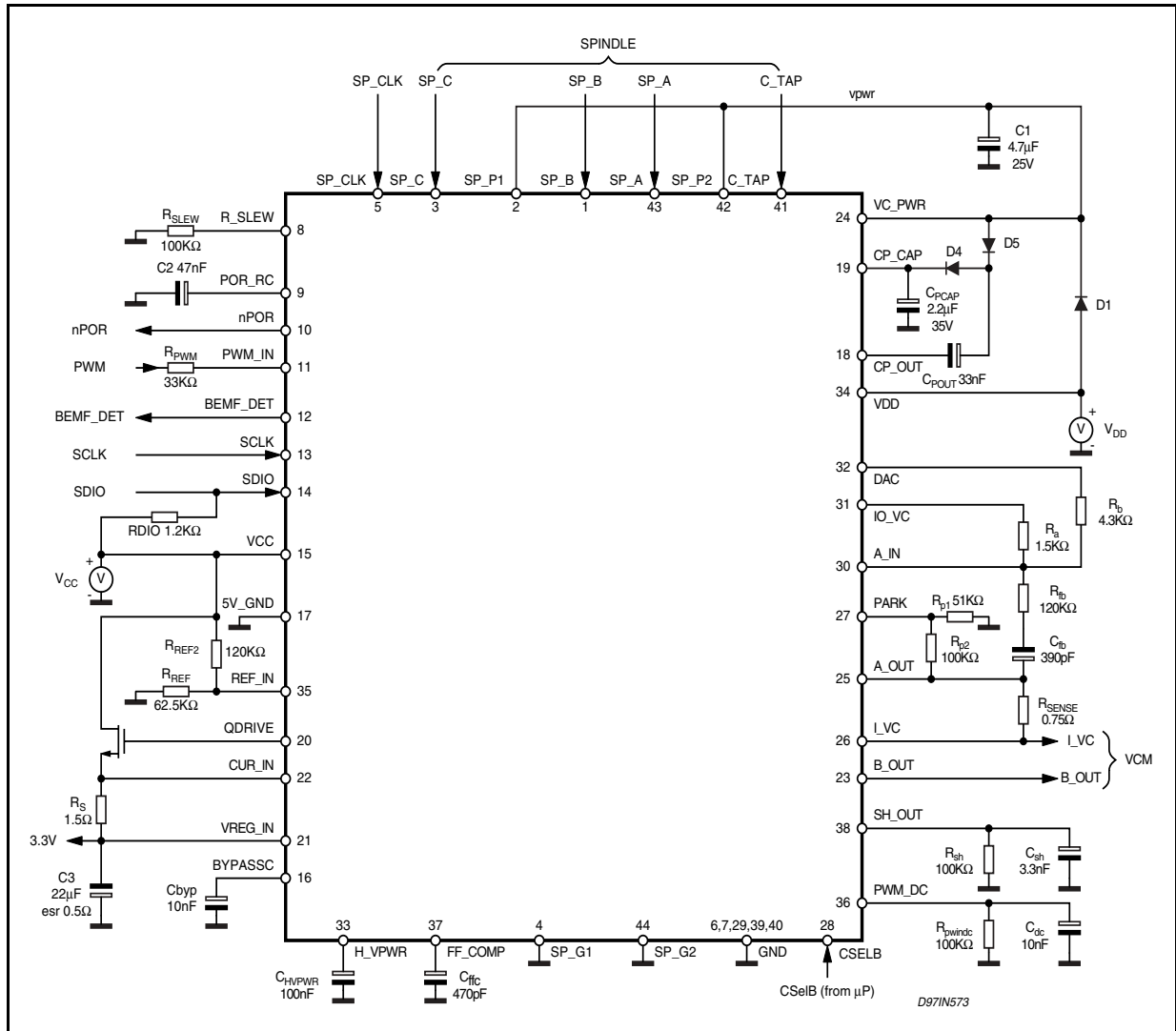

DESIGN FORMULAS:

1. Spindle Run Mode Slew Rate:

$$SR = \frac{1500 \cdot 10^3}{R_{slew}} \text{ (Volts } \mu\text{s)}$$

2. Feedforward Compensation:

$$F_{pwm} = \frac{1}{T_{pwm}} = \frac{1}{C_{ffc} \cdot R_{slew}} \text{ (Hz)}$$

$$D_{out} = \frac{T_{pwm}}{T_{pwm} + 0.7 \mu\text{s}} \cdot \frac{V_{ref}}{V_{rslew}} \cdot D_{in}$$

$$V_{ref} = \frac{R_{pwm_dc}}{R_{pwm}} \cdot 2.47 \text{ (V)}$$

$$V_{rslew} = \frac{(V_{pwr} + 0.8)}{1.86} \text{ (V)}$$

F_{pwm} = PWM chopping frequency
 D_{in} = Input duty cycle at pwm_in
 D_{out} = Spindle output duty cycle

3. Current Limit: $I_{limit} = 20 \cdot 10^3 \cdot \frac{V_{cc}}{R_{ref}} \text{ (A)}$

4. BEMF Zero Crossing Detector:

- Slope Compensation: $C_{sh} \cdot R_{sh} = \frac{5.9683}{V_{bemf} \cdot N} \text{ (sec)}$

N = Run mode speed of the motor in RPM
 - Window width:

$$t_{win} = 15404 \cdot \frac{V_{cc} \cdot R_{ref}}{R_{ref} + R_{ref2}} \cdot V_{bemf} \cdot N \cdot \text{Polepair} \text{ (}\mu\text{s)}$$

5. VCM PARKING VOLTAGE:

$$V_{A,park} = 0.5 \cdot \left(1 + \frac{R_{p2}}{R_{p1}} \right) \text{ (V)}$$

6. 3.3V REGULATOR:

Max Load Current: $I_{MAX} = \frac{0.3}{R_s} \text{ (A)}$



GENERAL BLOCK DESCRIPTIONS

(see figure 1)

Charge Pump

The Charge Pump provides bias for the upper drivers, for the brake circuit, and for internal circuitry as required for normal and spindown operation. Slew rate control is built in for quiet operation.

Serial Interface

The serial interface will transfer all control, status and data to and from the processor. Internal testing provisions have also been made through this port. The interface is compatible with an 8X196MP,NU or K17 series processor at low speed only, due to internal limitations of the processors. External chip select is mandatory on the L6256. Chip Select is also used to reset and synchronize the serial port. The serial port is used to indicate thermal shutdown of the Dolphin chip.

Brake Delay Timer

The brake delay will, upon start of a park or brake sequence, delay 128 negative zero crossings of the A spindle phase to allow the park circuit to operate. (The delay will typically be on the order of 400 msec.) Then the braking sequence can begin. The output of this timer is provided to the serial port registers to indicate the start of the brake action, and to indicate the start and end of the park period.

3.3V Regulator

The 3.3V external regulator provides a logic 3.3V using an external pass element (N channel FET), tied into the undervoltage detection system. It has the following features:

- Voltage mode control, using no external compensation.
- 3:1 foldback current limit to protect the pass element in case of component failure.
- Absolute regulation of 8% under all operating conditions

Control Registers

See serial port section.

Internal Testing

This circuitry is per vendor's specifications. No test functions actuated by the serial port software allow chip or drive damage to inadvertently occur. Double level write enabling is used. Differing vendor test requirements are accommodated using the unique vendor code bits. Various external pins are used for this function; consult the manufacturer's data sheets.

Spindle Section

SPINDLE CURRENT LIMIT

The spindle current limit value in start mode is set by the value of the external resistor on the Ref_In pin during start (which at start is shorted to Vcc, and the current out of the pin sets the current limit value).

During run, various internal methods are used to set a nominal maximum current value for circuit protection only. Consult the data sheets and application notes for a description of this circuitry.

Current limit operates on a cycle by cycle basis. The current limit comparator output is provided to the serial port to indicate when the spindle is in current limit. The current limit bit is reset when the status register is read.

NOTE: Current limit operation involves chaotic states, and careful firmware control can be used, if desired, to prevent audible squeals. Actual current limit value is also affected significantly by motor inductance. See application notes.

COMMUTATION COUNTER (CCTR)

The Commutation Counter provides commutation control for the spindle motor. It advances the spindle phases according to the bipolar phase control sequence, every time a SPIN_CLK positive edge is received. Its reset state (B C) is governed by the Commutation Preload Register (CPR). Operation of the register is synchronous with SP_CLK, but the reset is asynchronous.

COMMUTATION PRELOAD REGISTER (CPR)

During the initial start period, phase on/off control is preloaded into the counters from the Commutation Preload Register, which is loaded from the serial port. This allows direct commutation control from the processor. Various commutation schemes are implemented during startup by software through this register. High side bits take precedence over low side bits.

For both high and low drivers, logic high input to this register turns on the respective driver. Any pattern other than all 1's holds the CCTR in reset, and sets the MUX to bring data from the CPR register for the drive pattern. An all 1's pattern (an illegal state) releases the CCTR reset and switches the MUX to read the CCTR.

An all 0 pattern in the CPR spindle control bits both tristates the spindle drivers and resets the commutation counter.

The commutation latch holds data from either the CPR or the CCTR depending on whether all 1's are loaded into the CPR. The latch loads the previous state of the counter when the SP_CLK edge comes in. The latch circuitry also provides chop commutation information.

UPPER AND LOWER SPINDLE DRIVERS

The spindle drivers provide commutation switches. Internal inductive flyback protection is provided, dumping the energy into Vpwr node. This protection network also provides the energy transfer to the VCM to allow parking after power is lost.

The high/low and low/high slew rate of the drivers during run mode is controlled by the R_Slew pin to ensure that cross conduction with the lower drivers does not occur, and that excessive voltage slew rates are not produced. Provisions are made to drive inductive loads due to the possible filtering requirements. Windings must be damped with suitable external resistors to allow back EMF to be detected through the chopping waveform.

INDUCTIVE CLAMP CIRCUIT

The inductive clamp is applied to the motor pins to prevent the energy from the spindle motor coils from producing excessive voltages on the part, when the spindle drivers are tristated or when commutation occurs.

Back Emf Detect

The back EMF voltage from the spindle motor is monitored by a sample/hold circuit. First order slope compensation, set by the value of Rsh and Csh on the SH_Out pin, is used to reduce jitter. Sampling will occur during the spindle PWM on time, and hold during the off time and the ON_DELAY time. Slope compensation must be optimized for operation at run speed. During startup, the zero crossings are detected from all three phases. During run, only the falling edge of phase A is useful for timing. A very small amount of hysteresis is provided to prevent noise glitches. A fixed offset of approximately **Vebias** millivolts is internally introduced to the comparator during start mode.

The inductive flyback pulse must be masked by the width of the SP_CLK pulse provided by the Western Digital controller chip. The width of this pulse is affected by motor speed and current, as well as inductance.

Additional back EMF conditioning circuitry is being provided by Western Digital's digital controller chip. The back EMF_Det pin is masked for approximately 1/4 of the expected commutation cycle, and is latched to prevent multiple transitions.

At power on reset, BEMF_Det is tristated to allow for in circuit testing.

During run mode, the Ref_In pin sets a prequalifier comparator voltage level, which enables the zero crossing detection circuit about 20 μ s ahead of the actual position. Once speed has been stabilized, the spindle phase advance is used to adjust the EMF crossing to be coherent with the

PWM timing. This is done by observing the output of the prequalifier comparator and comparing it with the ON_DELAY signal internal to the chip. This output comparison is provided through the serial port.

Feedforward Compensation (FFWD Comp)

Any VPWR variations are nulled out by the ratio-metric adjustment of the PWM duty cycle. This circuit converts the fixed processor PWM frequency down to a frequency determined by the R_Slew resistor and the FF_Comp capacitor. This frequency is very constant over the entire specified supply voltage range.

VCM Section

VCM DAC

The VCM DAC buffer brings the VCM_DAC output up to the required drive capability. A 10 bit monotonic DAC is provided for the VCM.

ATTENUATOR SWITCHES

These provide variable attenuators for the VCM current control loop, settable from the control register. Attenuation settings are cascaded in binary form, thus requiring 1 bit for each attenuator. Ratios of 1.5:1, 2:1 and 4:1 give the additional combinatorial gains of 3:1 (1.5²), 6:1 (1.5⁴), 8:1 (2⁴) and 12:1 (all 3 attenuators on simultaneously). Attenuator gain ratios are not precisely controlled relative to one another and differ slightly between manufacturers.

An overall attenuator enable bit has been added to the VCM_DAC register address field. If this bit is a 1 (Combo compatible mode), then the attenuators are enabled. If the bit is a 0, then full gain is requested. This enables the VCM_DAC write to accomplish a complete gain shift and DAC write in a single serial port operation (2 bytes).

LEVEL SHIFT

The level shift circuitry shifts the center voltage of the VCM current command up to approximately half of the supply voltage, to provide for symmetric operation of the VCM power amplifiers.

The reference voltage output is a high impedance input point of approximately **Rref** ohms to allow for external bypassing.

VCM AMPLIFIERS

The VCM amplifiers are complementary class AB output amplifiers, with Bout having higher gain than the Aout amplifier. This ensures uniform saturation in either direction.

SATURATED SEEK BIT

The processor can command the VCM amplifiers to hard saturate, in the polarity determined by the sign bit of the DAC. The saturation detector bit is not the echo of this bit, but is a separate comparator bit representing the true state of the amplifier. Thus, it can be used for loopback testing of the DOLPHIN.

VCM CURRENT SENSE AMPLIFIER

The input differential voltage of the amplifier can be limited to low voltage, but common mode rejection is very high. The amplifier is capable of operating smoothly when the VCM amplifiers are saturated, providing no input charge buildup or other anomalies. Charge does not build up on the inputs even when VCM inductance forces the inputs substantially above the supply or below ground.

SATURATION DETECTOR

This detector notifies the processor when the commanded VCM current does not match the actual VCM current. The threshold is set by VC_Sat.

Fault Detection

UV DETECTION

The power supply undervoltage protection is set up for the appropriate tolerances, and causes a low signal on POR\ . A small hysteresis is included on the voltage comparators, and bandwidth limiting techniques are used. Current limit from the 3.3V regulator has been added to the POR error inputs.

POWER ON RESET (see appendix B)

The power on reset circuit provides the following functions:

- A retriggerable one shot of several milliseconds.

- An interlock circuit which provides for discharge of the one shot, and a clamp to hold the POR\ line low during the timing interval.
- Circuitry to pull POR\ high quickly after the 1 shot has timed out.
- A current source or weak pullup to pull the POR\ line high against external leakage currents.

Undervoltage conditions override external inputs and force POR\ low. External inputs do not cause pulse stretching; all internal inputs do.

PCBA in-circuit testing can arbitrarily pull this line low as necessary to restart the system. Alternately, a 1 milliamp current can be introduced to the timing capacitor to speed up the POR timeout.

THERMAL LIMIT

The thermal limit of the chip is set for **THlimit** with **THhyst** degrees of hysteresis. Thermal limit is a relative voltage, above **Thwarn** for tolerance reasons, and must protect the part; it indicates that thermal limit is taking place by disabling the serial port (see serial port section). A park and a spindle driver tristate is performed when thermal limit occurs.

THERMAL WARNING

Thermal warning is made available to the processor as a status bit in every register, to allow a modified control algorithm strategy that reduces power dissipation and drops chip temperature.

PARK CIRCUIT

The park circuit provides smooth head retraction. In Park, the VCM is switched to voltage mode. **Bout** is grounded. The A amplifier's positive input is switched from the normal half supply reference down to **Vpark**, and **Aout** applies the voltage determined by **Vpark** and **Rp1** and **Rp2**. This damps any motion that may be in progress and causes the head to retract into the latch.

Figure 2: Spindle State Diagram.

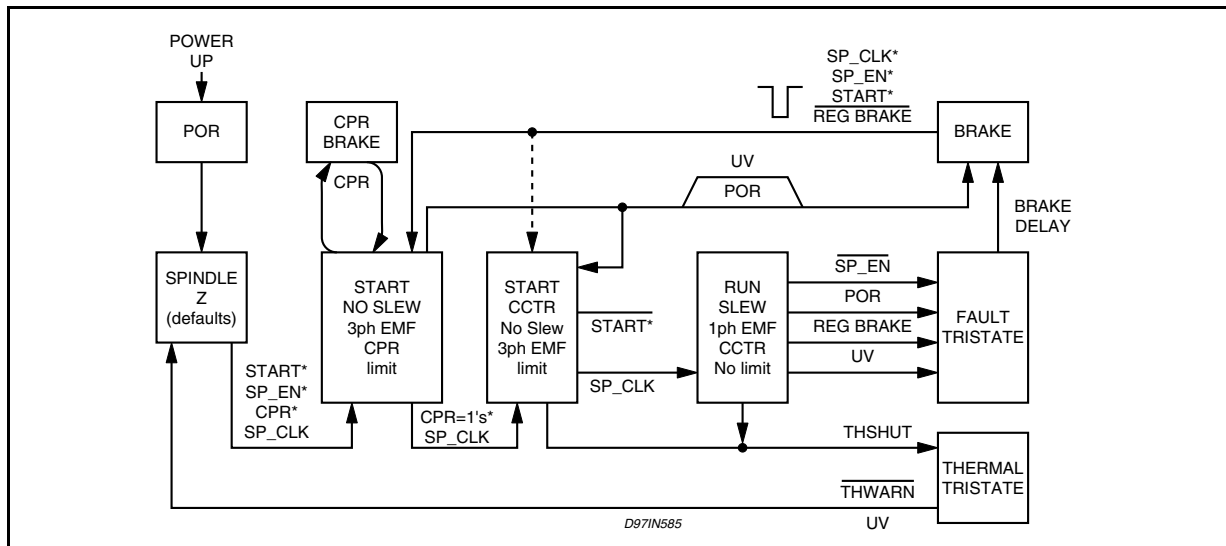

NOTE: In the spindle state diagram, in transitioning from Start mode to Brake, the CPR register is shown as being one possible path. The CPR register can be used to command a brake, which then causes the outputs to brake. This is called CPR Brake mode. However, a true brake state does not really occur. Specifically, current limit is still active.

NOTE: START and SP_EN bits and CPR is rewritten to get out of Spindle Z state. SP_EN must be pulsed.

NOTE: All spindle state transitions require an SP_CLK edge.

Figure 3: VCM section state diagram.

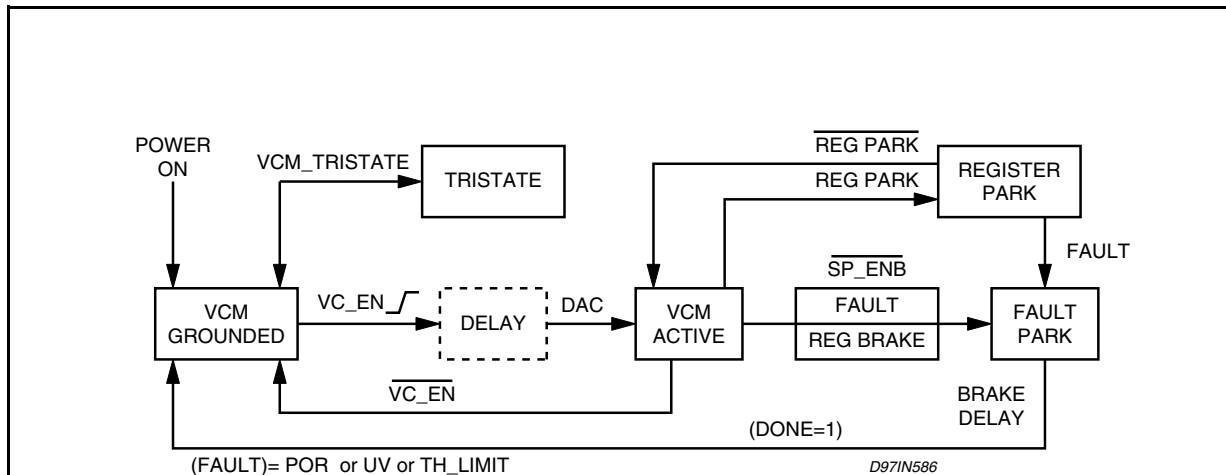

NOTE: VC_EN must be rewritten to get out of VCM Grounded state.

NOTE: At start, the spindle and VCM can now be simultaneously enabled. This is a VERY HIGH POWER DISSIPATION mode. If this is done, be sure to use the SAT_SK bit and duty cycle the VCM to keep chip power dissipation at a reasonable level.

ELECTRICAL CHARACTERISTICS**Power On Reset Section****POR SPECIFICATIONS**

Specification Parameter	Required Value
Vcc max undervoltage detect trip point, Vuv	4.06 to 4.3
Vcc trip point hysteresis	1%
Vdd undervoltage detect trip point Vuvd	9.3 to 9.8 volts
Vdd trip point hysteresis	1%
Max POR\ delay timing	100 msec
Forcing current to reset POR_RC (for in circuit test only)	nominal 1 milliamp
AC UV detection - nondetectable pulse Tuvmin (1)	1 μ sec
AC UV detection - detectable pulse Tuvmax (1)	20 μ secs

(1) AC detection test: done on either supply. With either supply at 0.2 volts above the trip point, a 1.2 volt negative pulse is applied. Chip must not respond to pulse width of Tuvmin, and must respond to Tuvmax.

Symbol	Parameter	Test Condition	Min.	Typ.	Max.	Unit
V _{min}	Required V _{CC} or V _{DD} for valid POR\ @25°C (7)			1.3	2.0	V
V _{tcap}	Timing Cap timeout threshold			2/3 V _{CC}		V
V _{cth}	Timing Cap threshold			(10)		
T _{strech}	POR\ pulse stretch width		5	40	100	ms (5)
T _{tol %}	POR\ pulse tolerance				±20%	(6)
T _{pmin acc}	external POR\ input required pulse width				300	ns (9)
V _{iw}	Voltage measurement point for T _{pmin}				0.8	V
I _{weak}	Pullup Current, POR\, steady state (at 3V)		100			μ A
T _{rise}	Rise time on POR\, internal driver with 100pF load (2)			100		ns
I _{pullup}	Pullup Current, POR\, momentary		3.2			mA

Notes:

- (1) dVmarg% The margining limit is determined as a fraction of the actual chip margin circuitry.
- (2) hysteresis on POR\ is optional.
Load: POR\ will see approximately 90 pF plus an external pullup source of approximately 6k ohms. No external bulk capacitance is used on POR\.
- (3) fall time measured from 2 volts to 0.8 volts.
- (4) pulse width measured from V_{print} volts on falling edge to 1.6 volts on rising edge.
- (5) is capable of meeting this timing with a 0.1 μ F or less, 20% tolerance ceramic capacitor. Nominal design point, .047 μ F is 40 ms \pm 20%.
- (6) Timing tolerance on POR pulse width irrespective of external parts.
- (7) POR\ is valid if either V_{cc} or V_{dd} exceeds this voltage.
- (8,9) T_{pmin acc} is the minimum POR\ pulse width which the combo must recognize as a valid external POR. This corresponds to the width of the reset pulse from the processor. Pulse widths narrower than this may or may not be recognized. T_{pmin rej} is the value of pulse width above which the combo should not recognize a pulse.
- (10) V_{bounce} is caused by the transition between the external POR circuit and the internal POR clamp circuitry.
in order to prevent deadly embrace with the microprocessor. The specified value is needed with 3.3V logic circuitry.

Figure 4: Power On Reset Waveforms and Timing

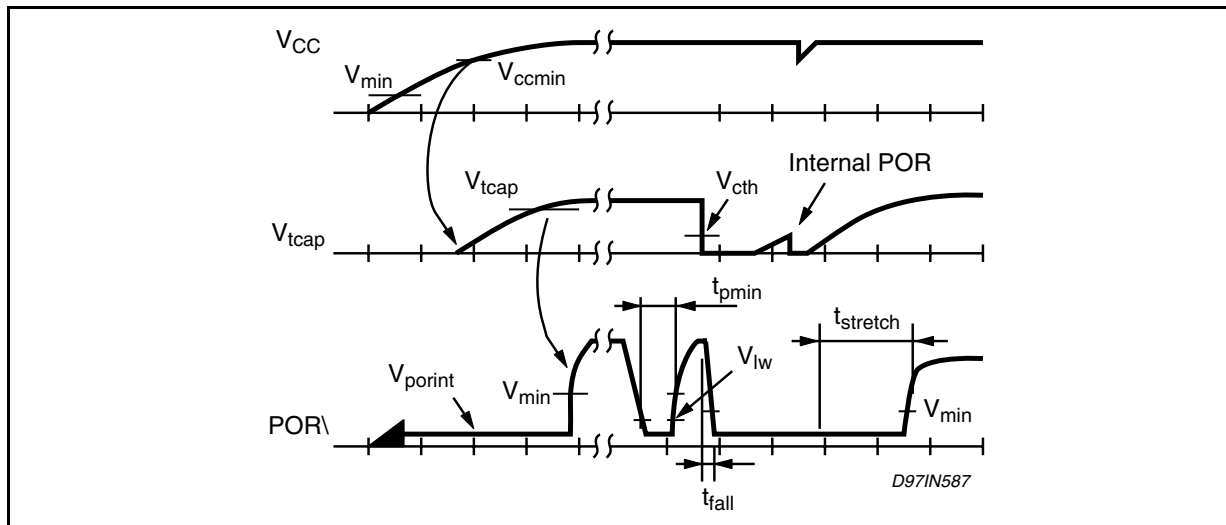

Thermal Shutdown Section

Symbol	Parameter	Value	Unit
T _{Hlimit}	Thermal Shutdown Die Temperature (1)	15 ±5 above Thwarn	°C
T _{hhyst}	Thermal Shutdown Hysteresis (1)	10	°C
T _{hwarn}	Thermal Warning (1)	145 ±15	°C

(1) Guaranteed by design

SERIAL PORT SECTION

General Specification

Data rate	6 to 12.5MHz
Clock Byte Synchronization	internal
Max load to external parts	15pF
Max external load	5mA or 1.2K pullup
Max bus load capacitance	60pF
Output Drive Structure	3 state, active high and low (not open drain)
Min Speed without dead bit	7MHz (see timing section) (1)
Internal pullup resistor	none

(1) Clock duty cycle of 40% to 60%

Protocol (general):

This protocol is part of a multiple chip protocol which affects several different Western Digital chip specifications. Changes to this protocol will affect several vendors.

Specifications for this chip conform to the timing specification

The serial protocol used to communicate with the chip is based on a fixed length 2 byte write or 3 byte read cycle (packets). Each packet sent to the chip is qualified by Dolphin chi select and by the address section of the first byte sent to the chip (bits transferred on clock cycles 2 through 4). The R/W bit determines packet length and bus direction.

At the end of the 16th bit (write) the data is transferred to the appropriate registers.

At the end of the 8th (read) bit, the internally addressed registers is ready to be placed on the serial bus. A dead bit is provided in all cases as the first bit read back from the Dolphin, to allow internal propagation delays and to provide for use of the clock to gate data into the internal shift register. At high data rates the processor has to insert some time in order to turn the bus around from write to read mode.

Multiple packets can be sent back to back without a dead space in between when other chips are addressed (except for the specified clock cycles inserted by the processor hardware). The chip is able to decode this case.

At high data rates, a dead space of at least 1 clock cycle must be allowed in between bytes of the packet for propagation delays internally.

Read and write clock rates may differ by as much as 2:1. Clock rates may differ between different chips using the bus.

A logic inversion may be used by other chips on the bus. If this is done, use of the chip select line after transmissions to the other chips is mandatory.

Chip Select

The external chip select masks out any incoming data. When inactive, the serial port bit clocking state machine is cleared, providing a resync mechanism. The chip select may not change states between every packet transmission, so it should not be counted on as a continuous signal. If the Dolphin is the only chip on the serial port, the chip select will only be used as an emergency re-sync if the chip doesn't answer queries.

If an address byte is received that is not addressed to the Dolphin while chip select is active, the Dolphin will ignore the transmission.

A metal option in the chip select circuit will allow for either polarity of active level. Present intention is for an active high level on the chip select pin.

Logic Inversion on Serial Port

If a logic inversion is used by other chips on the serial bus, the R/W bit will assume the wrong state and the Dolphin state mechanism will lose synchronization. In this situation, it will be mandatory for the processor to deassert the chip select to mask the serial port data intended for the other chip.

Typical bus waveforms are shown below, with the resultant activity.

Figure 5. Serial Port Chip Select Operation.

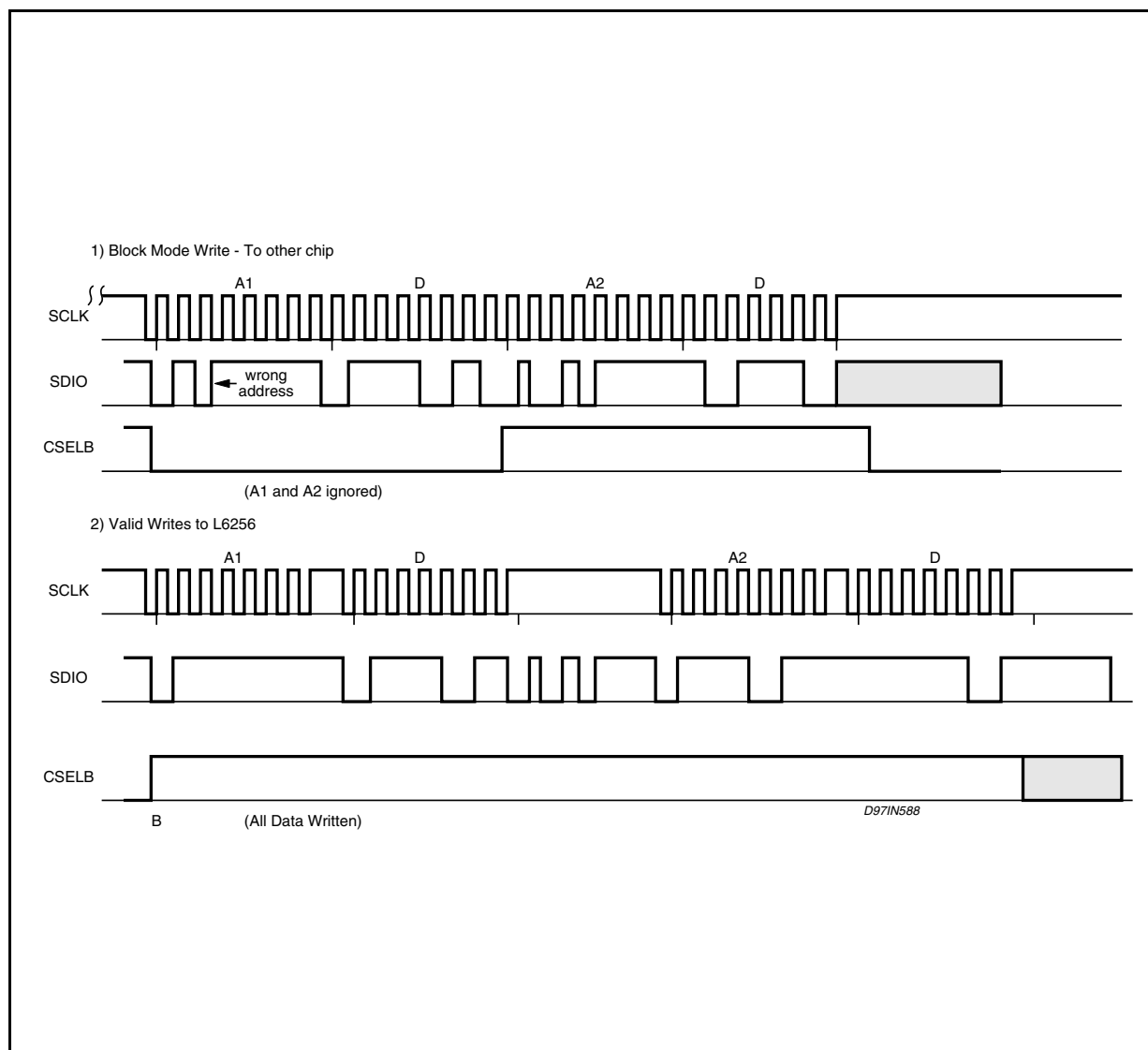
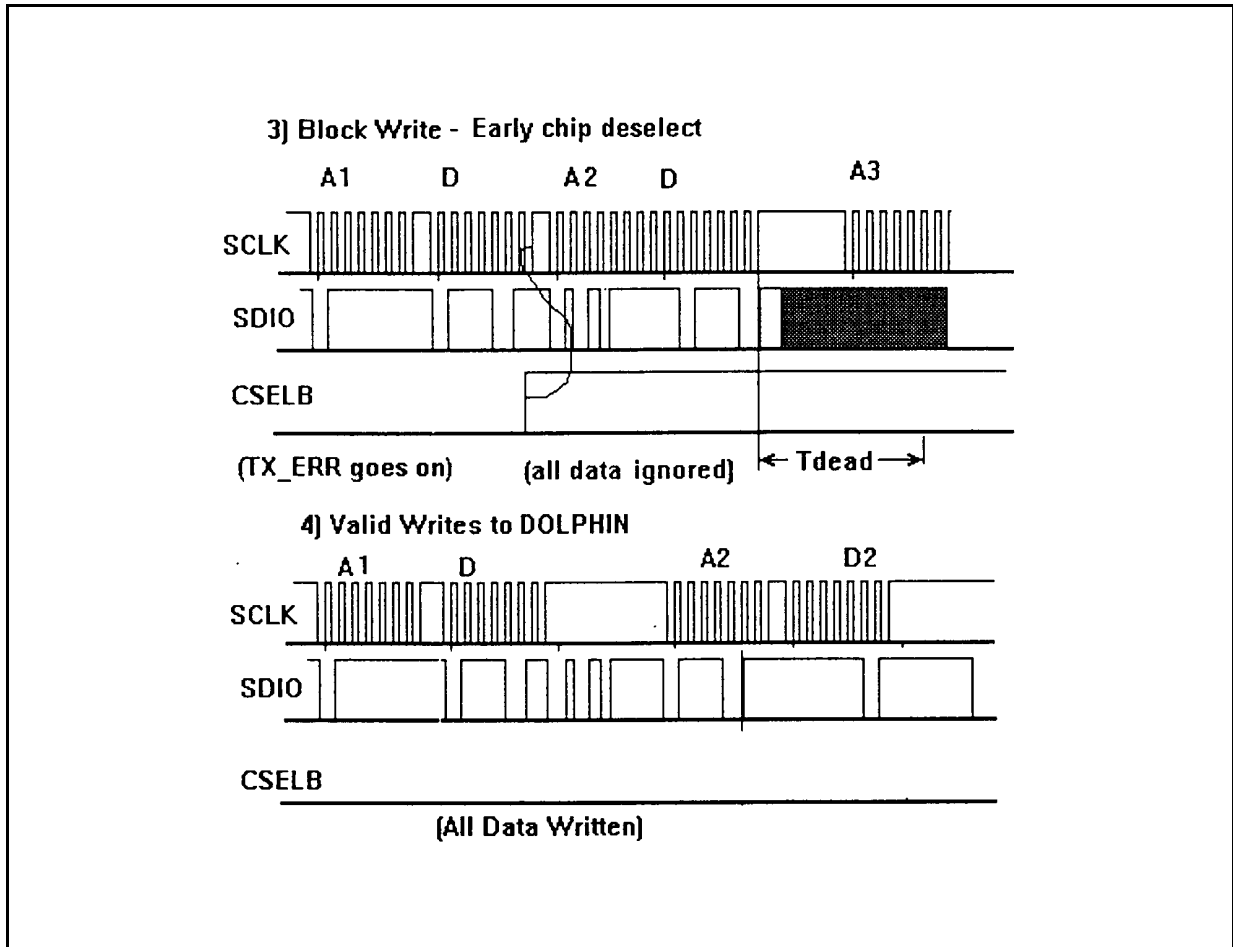

Figure 6. Serial Port Chip Select Operation.



Transfer Protocol Formats

Read:	3 Bytes								dead cycle
Bit #	0	1	2	3	4	5	6	7	
clock #	1	2	3	4	5	6	7	8	
Bit	R/W-	S0	S1	S2	R0	R1	R2	R3	1 cycle min (1)
Reply:									
Bit	D0 (null)	D1	D2	D3	D4	D5	D6	D7	
Bit	D8 (null)	D9	D10	D11	D12	D13	D14	D15	

(1) normally, this dead cycle time is met by the serial port turnaround delay time.

Format for write to the Dolphin DAC, 12V Combo Compatible mode:

Write:	10 Bits	to DAC							dead cycle
Bit	R/W-	S0	S1	S2	A0 (1)	A1	D8	D9	1 cycle min
	D0	D1	D2	D3	D4	D5	D6	D7	1 cycle min

Format for write to the Dolphin DAC:

Write:	10 Bits	to DAC							dead cycle
Bit	R/W-	S0	S1	ATT_ENB (*)	A0 (1)	A1	D8	D9	1 cycle min
	D0	D1	D2	D3	D4	D5	D6	D7	1 cycle min

(*) indicates a change in the specification.

If the ATT_ENB is a 1, then the DAC output attenuation will be enabled, and the attenuation will be whatever has been previously written in the VCM control register (this may include no attenuation at all). If the bit is 0, the attenuator is disabled and high gain is forced.

Format for write to all other Dolphin registers:

Write:	10 Bits	to DAC							dead cycle
Bit	R/W-	S0	S1	S2	A0 (1)	A1	D8	D9	1 cycle min
	D0	D1	D2	D3	D4	D5	D6	D7	1 cycle min

Format for write to the chips other than the 12V combo:

Write:	1Byte								dead cycle
Bit	R/W-	S0	S1	S2	A0	A1	A2	A3	none (1)
	D0	D1	D2	D3	D4	D5	D6	D7	none (1)

(1) There may not be a dead cycle between write addresses and their data bits when data is addressed to another chip on the serial port.

NOTE: All registers are accessible during POR to allow for in circuit testing. Appropriate functional chip changes may be occurring during the reset.

Serial Port Timing Specifications

Parameter	From/To	Min.	Typ.	Max.	Units
T_{setup}	V_{dh} or V_{dl} to V_{ch}	45			ns
T_{hold}	SCLK high to invalid SDIO, read	0			ns
T_{suw}	valid SDIO to SCLK high	10			ns
T_{holdw}	SCLK high to invalid SDIO, write			5	ns
T_{csck}	CSELB low to first falling clock			133	ns (1)
$T_{csckhigh}$	last rising clock to CSELB high			133	ns (1)

(1) CSELB specifications apply to both read and write operations. Timing is only shown in the read operation digram.

Minimum Timing for non-dead bit operation:

Timing Parameter	Ref Point	Min.	Typ.	Max.	Units
T_{scklow}	SCLK Vdl to Vdh	56			ns
$T_{sckhigh}$	SCLK Vdh to Vdl	56			ns

Threshold voltage for SDIO, internal to Dolphin:

V_{th}	SDIO Logic Threshold	1.0	1.2	1.7	V
----------	----------------------	-----	-----	-----	---

Test conditions for serial port timing spec:

Parameter	From/To	Min.	Max.	Units
T_{rs}, T_{rf}	SCLK rise, fall		5	ns
V_{dh}		2.4		V
V_{dl}			0.8	V
V_{ch}		2.4		V

Note: The serial port must meet these specifications up to the thermal shutdown temperature.

Figure 7. Serial Port Read Timing Waveforms

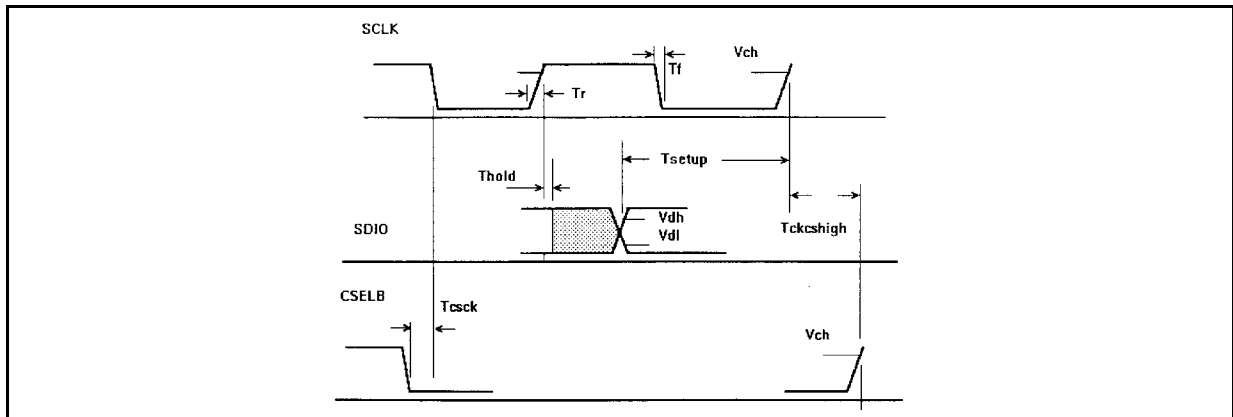

Figure 8. Serial Port Write Timing Waveforms

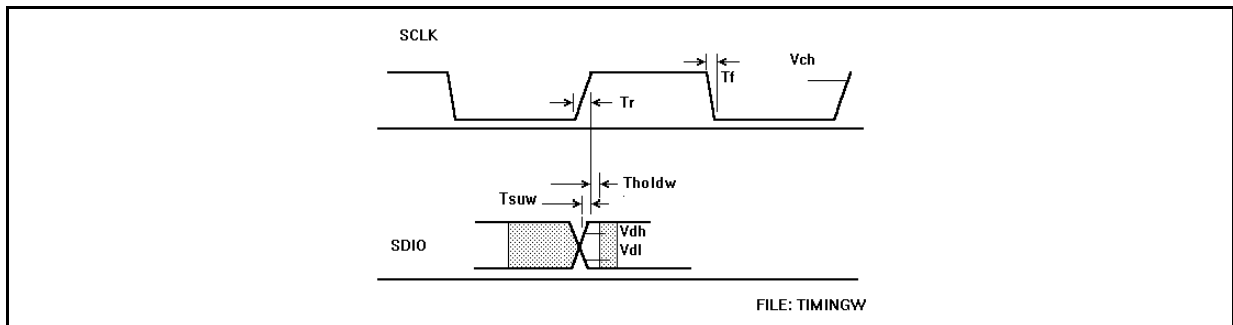

Table of Address Values

S0, S1, S2 always 1 - any other value indicates a packet for use by another chip.
 S2 may be used only as part of the VCM register address, as ATT_EN.

Register	A0-3	R/W
VCM DAC	11xx	Write Only
Aux Control Register	0111	R/W
VCM Control Register	0001	R/W
Commutation Preload Register (CPR)	0011	Write Only
Test Register (*)	1000	R/W
Status Register	0100	Read only

(*) represents revised specification. The test register is now implemented in both chips

REGISTER BIT DEFINITIONS

All bits in the control registers are asserted (true) when positive. The appropriate status bit answers to the same address and bit location as the writable bit which causes the action. This means that when a read is performed, the actual value read back is not just an echo from the write register, but represents the status of the function requested. In most cases this is a direct, unlatched output from internal circuitry.

Most status bits are reset after being read once. The control registers have control bits as follows:



VCM Control Register			Address: 0001		
Bit Function	Mnemonic	Bit #	Init State	R/W	Read 1 indicates:
VCM DAC attenuation switches - 3 bits (5)d					
1.5:1	ATT0	0	xxx	W	N/A
2:1	ATT1	1	xxx	W	N/A
4:1	ATT2	2	xxx	W	N/A
Thermal Limit	TH_LIM	3	0	Read	Th Limit
Register Park	RPARK	4	On	R/W	Park Delay is Occuring (1)
Saturate Seek	SAT_SK	5	0	R/W	Driver Saturated (2)
VCM Tristate	VCM_3S	6	xxx	W	Tristated (3)
VCM loopback (read)	VCM_LP	7	xxx	Read	Current Outside Window (4)
Done Disable (write) (6)	DONE_DIS	7		Write	

- (1) Register park will not cause a brake to occur. The register park bit will also go low during a register brake, indicating to the firmware that the brake sequence has been initiated.
- (2) Saturated seek bit, when 1, will cause the VCM drivers to saturate, with the polarity of the sign bit in the VCM DAC register. A read of this bit indicates that the commanded current differs from the actual current (output of the saturation comparator). NOTE: this is not just an echo of the state of the written bit, but actually represents the true status of the VCM current loop.
- (3) This bit tristates but leaves internal circuitry active for external test (ST), or is unused (Unitrode). The DONE_DIS bit has been moved (see note 4).
- (4) VCM loopback is optional. Use the saturated seek bit for test purposes. The DONE_DIS bit is used to end the park timer cycle, which may be necessary if the chip is ever put into run mode at low speed.
- (5) Exact attenuation ratios may vary slightly between manufacturers. See data sheets. Attenuators are now gated by ATT_EN, which is located in S2 in the address space of the VCM register. If ATT_EN is high, the attenuation is set by the value in this register. If ATT_EN is low, full gain (no attenuation) is selected. This allows rapid switching between low and high gain with the same write packet as that used to write to the DAC.
- (6) DONE_DIS MUST be cleared when entering run mode, or the park timer will stay off. This bit should never be used except during error recovery.

Commutation Preload Register (CPR-Write only)		Address: 0011	
Bit Function		Bit Address	
Spindle ABC low enb (3 bits)		initial state: XXX (2)	
A low enb		Bit 0	
B low enb		Bit 1	
C low enb		Bit 2	
Spindle ABC high enb (3 bits)		initial state: XXX (2)	
A high enb		Bit 3	
B high enb		Bit 4	
C high enb		Bit 5	
Spare		Bit 6	
Spare		Bit 7	

NOTES:

- All bits become valid only on a rising SP_CLK edge, except CHB_ENB.
 - Spindle high bits override low bits. Transition from low to high and vice versa are interlocked against simultaneous enables or momentary shootthrough.
 - An all 1's pattern in this register, bits 0 through 5, causes the internal Commutation Counter to begin operation on the next SPIN_CLK input edge. Any other pattern causes the spindle Commutation Counter to reset (BC\ state).
- (1) CHB_ENB, when high (the POR and default condition), allows the back EMF chop blanking comparator to disable spindle PWM off periods during the A phase negative crossing (see back EMF detection section). Initial state varies between vendors.
- (2) The 6 bits which determine the spindle driver must be set to all 1's before entering run mode or the CCTR will not run.

Auxiliary Control Register		Address: 0111			
Bit Function	Mnemonic	Init State	R/W	Bit #	Read 1 indicates:
Start (1)	START	xxx	W	0	N/A
VCM enable (2)	VC_EN	0	W	1	enabled (5)
Spindle enable (3)	SP_EN	0	W	2	enabled (5)
Thermal Limit	OVTEMP	0	R	3	Th Limit
Test Enable (7)	T_EN	0	W	4	enabled (5)
Software POR	SPOR	off	W	5	always 0 (5)
Spare					
Register Brake	RBRAKE	disabled (4)	R/W	7	Braking * (6)

NOTES:

- (1) Start disables slew rate control. It also changes the back EMF detection circuitry from 3 phase to single phase.
- (2) shuts down active circuitry and drives to the ground state when 0. A transition on this bit is required to reactivate the VCM. see state diagram.
- (3) shuts down active circuitry and tristates when 0. A transition on this bit is required to reactivate the spindle circuitry. see state diagram.
- (4) Writing to brake will cause a register park, then a brake sequence (an internal POR), without causing an external POR\ . Thus, the rest of the system including the processor will not be reset.
- (5) Optional bits.
- (6) The register brake function has been redesigned to allow use of a momentary, current limited brake during start mode only. Asserting this bit overrides the CCTR or CPR register contents without disturbing them, and causes a brake on the spindle outputs. Resetting the bit restores the previous state (the outputs were in before the bit was asserted). DO NOT attempt to change the CCTR or CPR, or send a SP_CLK while this bit is asserted.
- (7) Test Enable is used to enable manufacturer specific test circuitry within the chip. This bit should be initialized with a 0 value and left at 0 at all times. Do not attempt to use this bit for any reason unless you have complete manufacturer specific information.

Test Register		Address: 1000	
Bit Function	Init State	R/W	Read 1 indicates:
Bits: TBD	up to 16 read, 8 write		

NOTE: The test register requires 2 level access. That is, the test enable bit in the Aux Control Register must be written to with a 1 or the test register is locked out.

Status Register (read only)	Mnemonic	Address: 0100	
Status Bit		High Indicates	Address
Dead Bit (unusable for timing reasons)	-	n/a	Bit 0
UV detect	UV_DET *	Undervoltage Occuring	Bit 1
Overtemperature Warning	TWARN	Exceeded Warning Temp	Bit 2
Overtemperature Shutdown	OVTEMP	Exceeded Shutdown Temp (1)	Bit 3
Version Number (2 bits)	VERS *	(2)	4 = Bit 0 5 =Bit 1
Vendor Number	VENDOR	(2)	Bit 6
Spindle Current Limit	SILIM	Current Has Exceeded threshold (7) (8)	Bit 7
Dead Bit (unusable for timing reasons)		n/a	Bit 8
EMF XOR Output	EMFX	Changes state on XOR of Comparator A, B, C	Bit 9
EMF A Comparator Output	EMFA	Positive High	Bit 10
DAC write	XOR	Write (3)	Bit 11
Transmission Error	TX_ERR *	CSELB occurs during active transmission (4) (7)	Bit 12
Aux_Write	AUX_WR	Toggles (5)	Bit 13
Phase Detect	PH_DET	Correct PWM phasing (6)	Bit 14
Spindle Forward	SP_FWD *	Reports correct spindle rotation direction	Bit 15

NOTE: the status register is readable during a POR\ for in circuit testability.

- (1) Overtemperature Shutdown or Warning do not cause POR\ . This arrangement allows graceful recovery from overtemperature conditions.
- (2) Vendor bit = 0 for Unirode, 1 for ST. Version number, Bits 0,1 allow 4 chip versions. For the Dolphin: Bit 0 = 1, Bit 1 = 0. This allows de-



tection of the 12V Combo vs. a Dolphin chip

- (3) the DAC write bit toggles every time a byte is written to the DAC. This provides confirmation that the write actually took place.
- (4) Detects spurious or missing SCLK edge count between CSELB edges.
- (5) flips state whenever either ACR or VCR is written to successfully. This bit can be used together with the **TX_ERR** bit to see whether data was changed in the Dolphin.
- (6) If the back EMF chop blanking comparator goes high during the PWM **On_Del** period, this bit is set to a one. See the back EMF section.
- (7) bit is reset every time the register is accessed by the processor.
- (8) current limit bit works in run mode as well as in start mode. If current limit is ever detected in run mode, the chip should be immediately tristated.
- (9) A1 in this bit indicates the correct (forward) phasing has been detected by the back EMF circuitry. Specifically, at the negative edge of SP_CLK the back EMF comparator must be in the expected state, or else the bit is cleared. Updated on every negative SP_CLK edge.

SPINDLE CIRCUITRY SPECIFICATIONS

Spindle Circuitry Specifications

Symbol	Parameter	Test Conditions	Min.	Typ.	Max.	Unit
T_{brake}	Braking Time	$V_{emf} = 7V$	8			s (1)
	Start Mode Current Limit (bipolar)	$R_{ref} = 62.5K$ 1%		1.6		A
	Start Mode Current Limit Tolerance	Startup I_{peak}			±7%	of programmed current (2)
SR	Slew Rate	At speed (3)	12	15		V/μs
	Vpwr current spiking	At run speed			25%	above spindle run current
	Slew Rate range adjustment		0.5:1		2:1	(4)
	Run Mode Current Limit		0.7	1.0	1.6	A
	Spindle Output Current Leakage (6)	Tristate	-100		+100	μA
	Snubber caps		0		0.01	μF 20%

- (1) braking on the spindle motor must remain active for the full braking time. This parameter is guaranteed by a leakage specification. Full power brake is 3 seconds maximum.
- (2) excluding Vcc tolerances.
- (3) Slew rate at startup is limited by the parasitic diode reverse recovery times so that the peak current spikes in the power supply are no larger than 25% above the motor run current.
- (4) Slew circuitry must internally be able to drive stated snubber loads and be adjusted from 0.5 to 2 times the nominal value. This implies that Rslew is able to be adjusted from 51K to 200K without causing circuit problems within the chip.
- (5) Run mode current limit is strictly a protection mechanism to protect against spurious SP_CLKs or improperly programmed timing. Max limit is a manufacturer limit determined by safe operating area considerations for the spindle FETs. The minimum limit determines the maximum chip loading during run time. Since this is strictly an internal limit, tolerances on this value are very wide.
- (6) Spindle Output Leakage must not interfere with back EMF sensing at any time.

Feedforward Circuitry Specifications

Symbol	Parameter	Test Conditions	Min.	Typ.	Max.	Unit
$t_{off\ min(1)}$	Minimum off time			20/SR		μs
	PWM to DC Conversion	(2)	100	110		% of full scale
	Chop Frequency	(3)		22	-	KHz
	PSRR, Spindle	(4)	32	-	-	dB

- (1) The purpose of **toff min** is to guarantee a full rise and fall time of the spindle chopper output circuitry at the minimum supply voltage. The timing circuit which determines **toff min** internally tracks the slew rate circuitry to keep this relationship true, while keeping **toff min** as small as possible.

NOTE: dynamic current limit considerations will usually limit the off time even further.

- (2) For the PWM to DC conversion, the following standard conditions apply:

Rpwm = 33K 5%

Input impedance of processor driver, 100 ohms

Assume driver is at 100% duty cycle

RpwmDC = 100K 5%

Cdc = .0033 μF 5%

At these values, the output produces **toff min** at Vpwr = 10 volts so that full scale is reachable.

- (3) With Rslew = 100K 1%, Cfc = 470 pF 5%, and including chip input capacitance, the output must not go below 20 KHz over the range of toff min values.
- (4) PSRR is defined as the ratio of average output voltage to the motor over the Vpwr change: $-20\log_{10}(dV_{out}/dV_{pwr})$
It is tested by injecting a 0.6V peak square wave on Vpwr and Vdd from 1 Hz to 10 kHz. The specification applies over the entire Vpwr range.

Spindle Logic Interface Specifications

The digital interface to the controller chip has the following specifications:

Parameter	Min.	Max.	Units
SP_CLK, V_{oh}	$V_{CC}-0.8$		V
SP_CLK, V_{ol}		0.5	V
EMF_Det V_{it+}	$0.7 V_{CC}$		V
EMF_Det V_{it-}		$0.2V_{CC}$	V
EMF_Det Hysteresis	$0.1V_{CC}$	$0.3V_{CC}$	V
EMF_Det I_{ij}		-1	μA
EMF_Det I_{ih}		1	μA
EMF_Det Load		30pF, 1.6mA	

The SP_CLK is a CMOS output. The EMF_Det input is a schmitt trigger with the specified thresholds and leakage currents.

Vpwr Blocking Diode

The blocking diode in the Vpwr line is optionally a non-schottky part. If this occurs, schottkys should be used in the charge pump to provide the proper voltage at minimum supply. If regular diodes are used in both places, the part is functional (at 10% increased R_{dson} in all drivers) at the lowered Vpwr voltage.

Figure 9a. Run Mode Spindle Voltage Waveforms

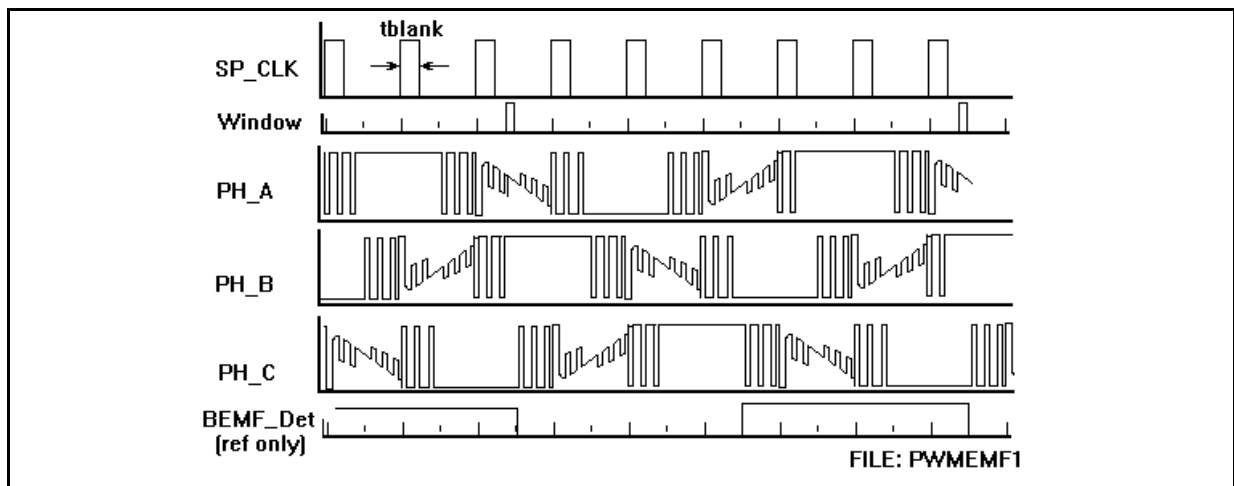
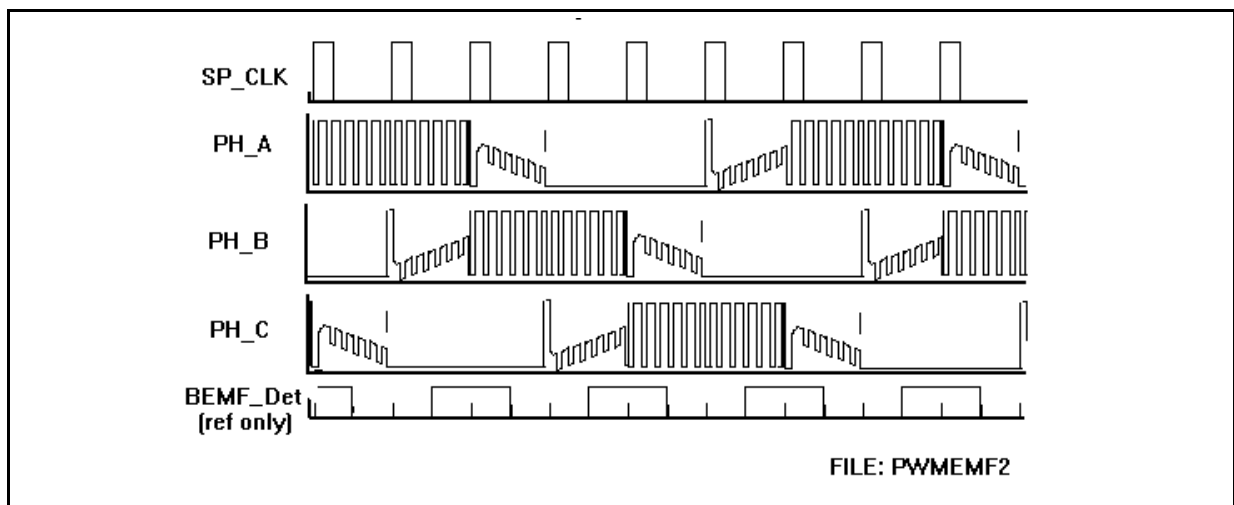

Figure 9b. Start Mode Spindle Voltage Waveforms



Motor Waveform Specs. / Diagrams

It is necessary to center the center tap voltage by using symmetrical drive waveforms on the spindle motor drivers. This necessitates a chopped waveform on both the high and low side drivers. The pattern alternates between a high and low chop on every back EMF cycle during run mode.

NOTE: the off time of the PWM chopping cycle is not disturbed when switching chop polarities for audible noise reasons. The change of polarity is produced by checking the EMF state at the start of the on portion of the chop cycle.

NOTE: SP_CLK positive pulse width (**tblank**) is 25 +/- 6% of the commutation period.

Supply Voltage Feedforward Compensation

The power supply voltage ripple arriving at the spindle power input pins would normally directly feed through into the spindle motor, causing unacceptable speed deviations. The feedforward circuitry cancels the voltage ripple on the power supply by correcting the PWM duty cycle appropriately. It also reduces the PWM chop frequency to the minimum required to reduce noise and allow slower slew rates. Finally, it adds substantially to the resolution of the control loop by removing supply tolerances from the required range calculations, and by cancelling power supply variations which would normally have to be taken into account by the loop.

Supply Feed Forward Circuitry

The feedforward circuitry consists of:
Bias Generator

This circuitry generates a fixed current level that generates a very stable frequency in the local oscillator that is independent of supply voltage.

PWM_DC converter

The processor PWM input has several problems which prevent it from being used directly. The PWM_DC converter converts the PWM input to a DC voltage so it can be rechopped.

The bias generator provides a reference voltage that is used to convert the PWM_IN input from a voltage to a DC current value (set by Rpwm, the input resistor). The duty cycle on this pin thus produces a duty cycled current on the PWM_DC pin. The RC time constant and the value of the resistor on the PWM_DC pin then converts this pulsed current into a DC voltage with a small amount of ripple.

Level Shift

The level shift takes the voltage on the PWM_DC pin and scales it to the resistor ladder reference (Vrh) to set the ratio of DC voltage to reference voltage properly.

Local Oscillator

The local oscillator produces a sawtooth wave whose amplitude is directly proportional to the power supply voltage. It does this using the slew rate resistor (Rslew) instead of the bandgap reference, and Cffc, the oscillator capacitor. The local oscillator must maintain a constant frequency so that it can be easily synchronized with the back EMF detection circuitry. Note the diode in the resistor ladder network, which compensates for the

Commutation State Table

Bipolar	
BC/	State 0 (reset)
BA/	State 1
CA/	State 2
CB/	State 3
AB/	State 4
AC/	State 5

NOTE: Before attempting Tripolar operation, consult the application notes.

Tripolar		
A	B	C
High	Low	High
High	Low	Low
High	High	Low
Low	High	Low
Low	High	High
Low	Low	High

output stage flyback diode voltage.

Off Time One Shot

The off time one shot guarantees that a minimum off time occur in the output of the spindle PWM waveforms. This prevents subharmonic cycling, and prevents partial transition in the output waveform. Additionally, it provides a fixed time delay which allows accurate synchronizing of the PWM waveform with the commutation input (SP_CLK). Finally, it prevents tolerance buildups in the circuitry because the PWM_DC circuitry can be designed to allow higher than full scale voltage with-

out fear for causing audible subharmonics.

Output Comparator

This comparator produces the PWM chop duty cycle for use within the spindle drivers, now corrected for power supply variation.

On delay Comparator

The on delay comparator provides a warning signal for the back EMF detection circuit brackets the worst part of the turnon transient that occurs on the back emf detection winding.

Figure 10. Supply Feedforward Circuit Diagrams.

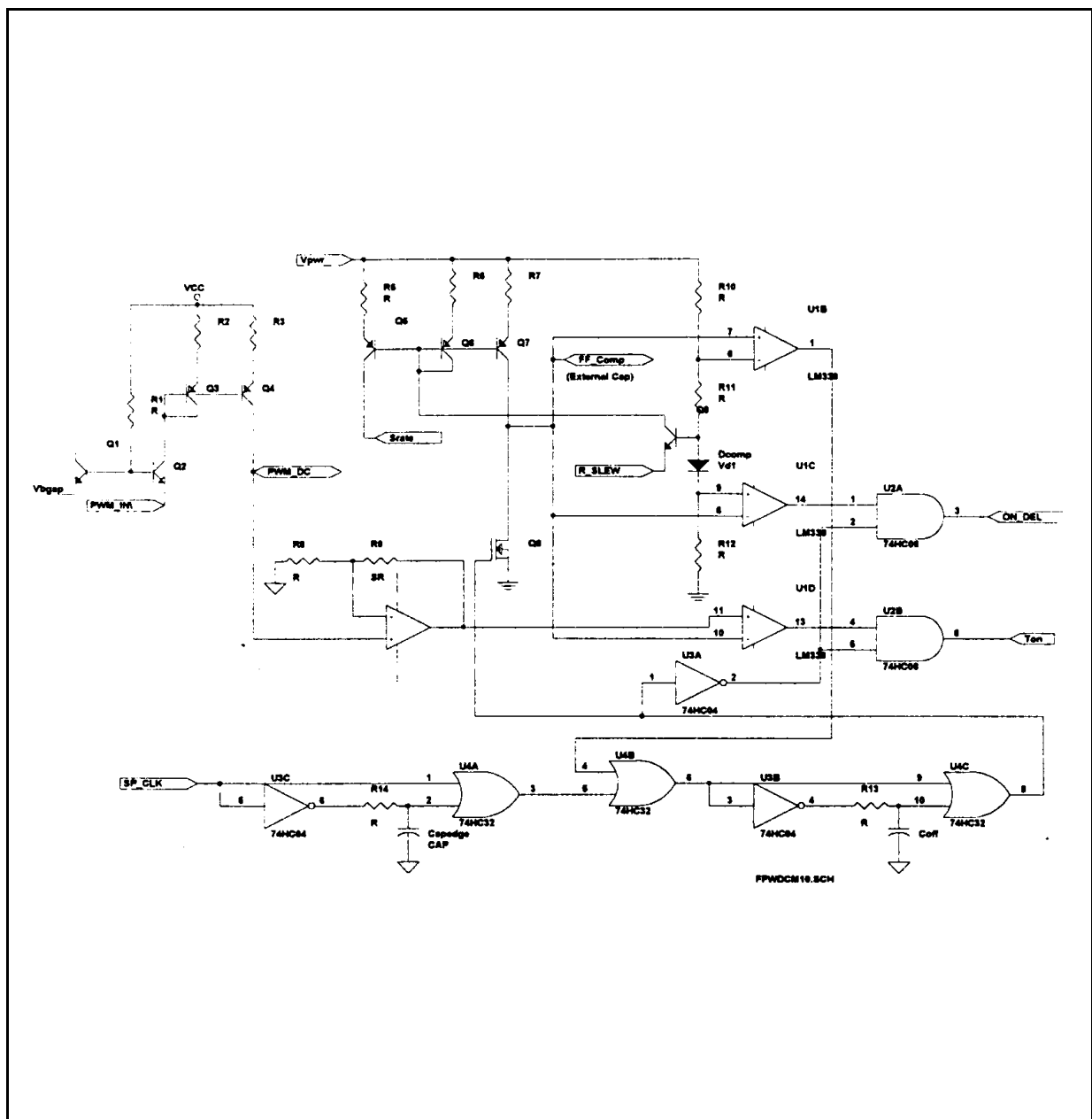

Figure 11. Supply Feedforward Support Circuitry.

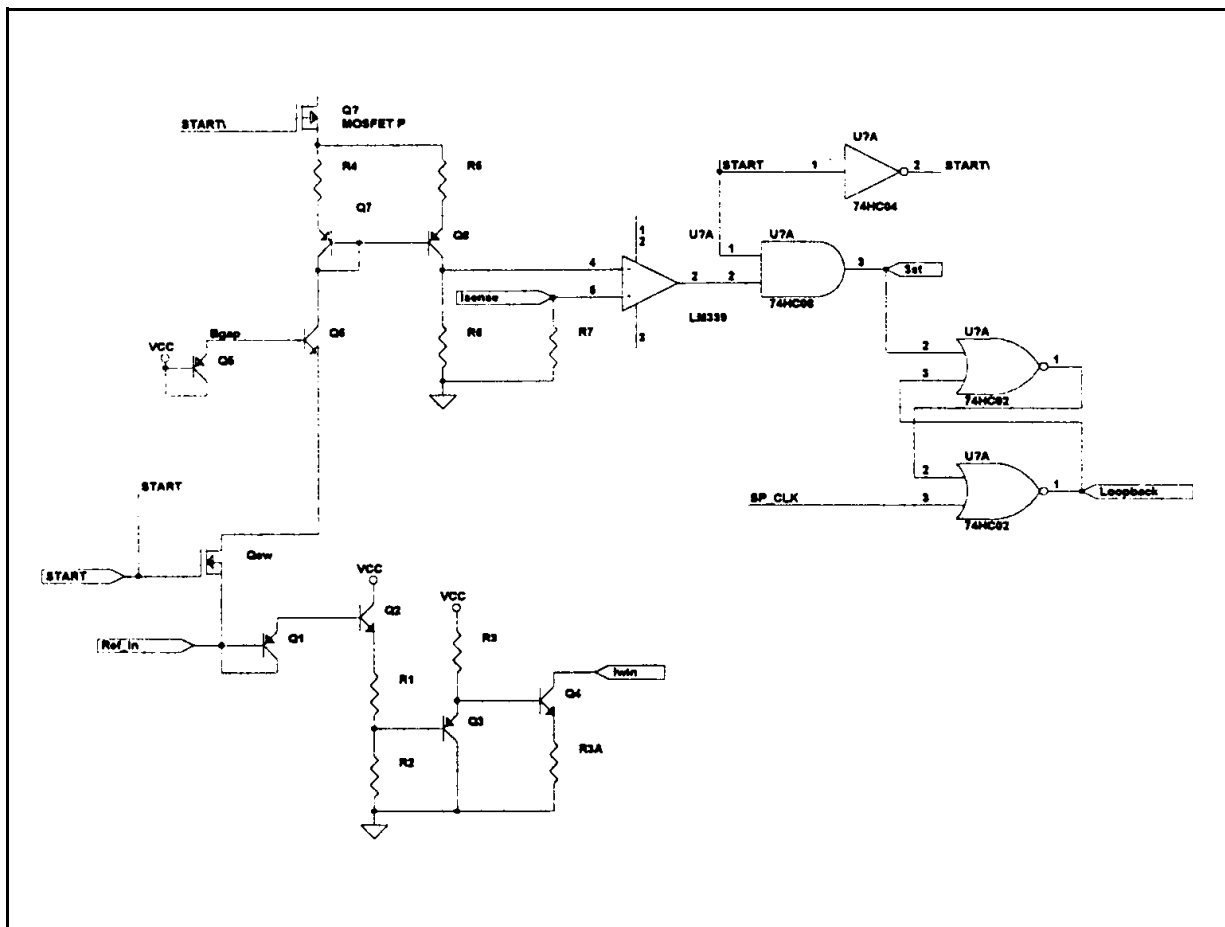
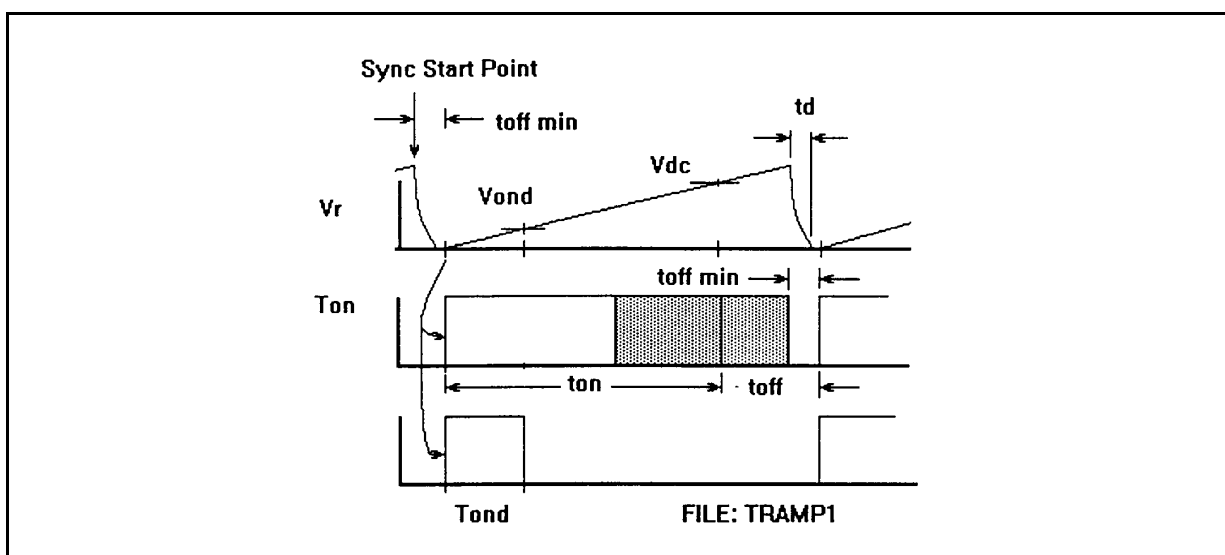

Figure 12. Ramp Oscillator Waveforms.



NOTE: toff min is greater than the total fall and rise time of the spindle output waveforms. This ensures that a complete off cycle always occurs.

Ideally, toff and the slew rate would be related. T_{ond} is used by the back EMF detection circuitry and is nominally about 20% of the total duty cycle.

Back Emf Detection

Back EMF detection has 2 different modes of operation: Start mode (determined by the manufacturer), and Run Phased mode. These are determined by the state of the Start bit.

BACK EMF RUN MODE SPECIFICATIONS

Parameter	Test Conditions	Min.	Typ.	Max.	Units
Rshold Output Impedance	25°C		150	250	Ω
Chop Blank Pulse width tchb	(1)	23.5	25	27.5	μs
On Delay width	(2)	20	22	24	% of ramp rise time
BEMF start mode detect offset - Vebias		±40mV			
BEMF detect hysteresis		10mV nominal			

(1) At 6000 rpm, 8 pole motor, sinusoidal EMF from center tap to the A phase of 8 volts p-p, Rref = 62.5K 1%, Rref2 = 120K 1%.

(2) on delay width is from the end of off time to the end of On_Del. Measured at max duty cycle (no off time due to feedforward compensation). Specification allows for toff min, to set nominally 20% width of total cycle time.

START MODE

During startup, all 3 back EMF phases are used. The output going to the BEMF_Det line is the exclusive or of all 3 phases, and follows the polarity of whichever phase is currently tristated (relative to the center tap voltage). If the processor is driving the motor directly from the CPR, the back EMF circuitry is still active. Tripolar mode by nature prevents EMF detection. EMF transitions are partially blanked by the controller chip in all modes.

Run Phased Mode

The Run Phased Mode is now the default (and only) state in the DOLPHIN during run mode.

The chop waveform is injected into the back emf waveform of the unused winding due to transformer coupling and the action of the center tap. Most of the transient is removed by using a high CMRR amplifier before the signal gets to the sample/hold circuit, and by holding during the off time of the chop. However, a small residual is left on the sample/hold waveform. This small transient must be kept away from the back EMF crossing point or it will cause an unstable loop. This can only be done if the PWM on edge is at the proper timing relative to the back EMF point.

A comparator is provided internally that generates the proper delay point by comparing the back EMF waveform against a small offset voltage (settable externally). The programmer must then vary the commutation timing until the **PH_DET** bit goes high, indicating that the chop and EMF crossing waveforms are properly phased. This timing is produced by modifying the phase delay in the controller chip until **PH_DET** is high.

Note that the **PH_DET** bit is updated at the rising edge of the chop blanking comparator. If the On_Del signal (the blanking signal that frames the EMF on transient) is high during the edge, then the transient is in the proper position.

The timing of the proper position is set by several external variables; the PWM frequency, the running RPM speed, and the external reference voltage.

The relationships of the chop blanking comparator, the On_Del signal, and the Ph_Det bit in the serial port are illustrated in fig. 13.

Figure 13. Back EMF Chop Blanking Mode Waveforms

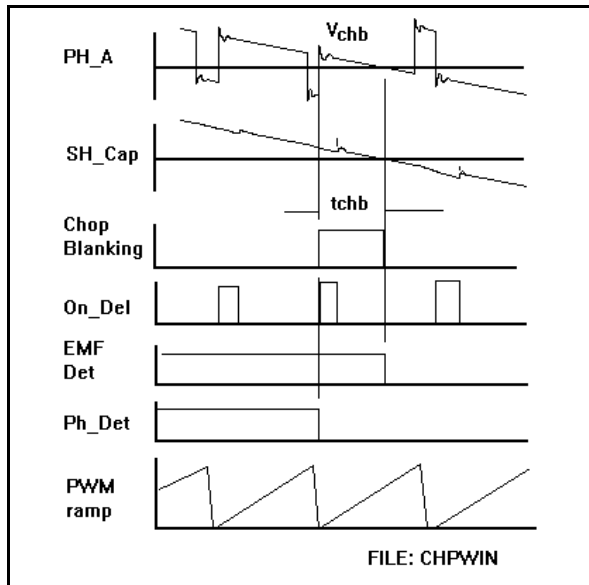
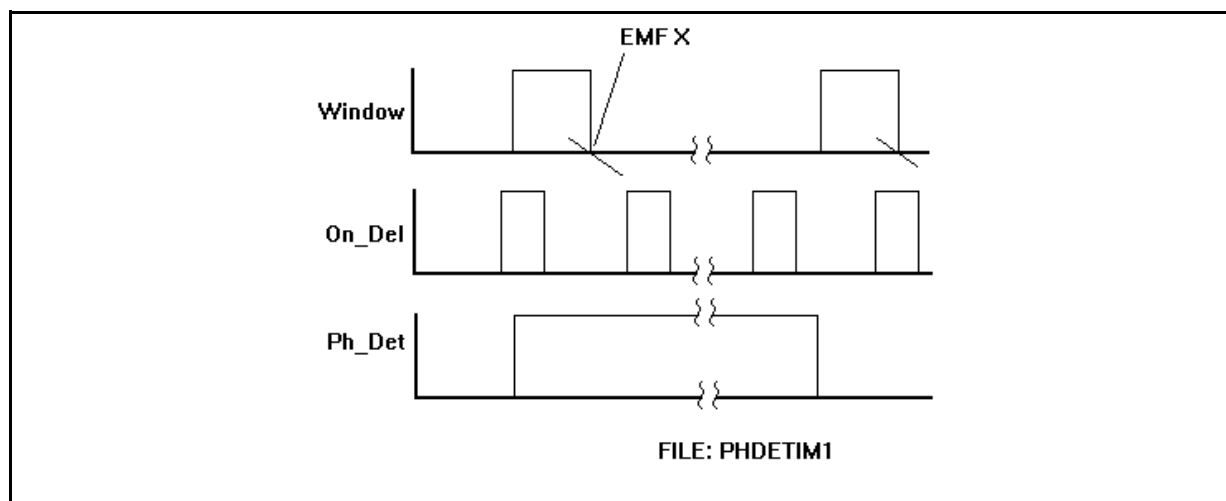

Figure 14. Back EMF Phase Detection Timing Relationships



TRANSITIONS

Transitioning from blind table drive to a back EMF mode drive is handled in the following manner. Remember, data written to the CPR takes effect only when SP_CLK receives a positive transition. The following steps must be taken:

- The programmer must ensure that the last state before state 0 has been output to the CPR and clocked in using SP_CLK.
- An all 1's value is written to the CPR to enable the state counter.
- The next SP_CLK will then produce a state 0 from the sequencer.

Voice Coil Driver (Vcm) Section

VCM SECTION SPECIFICATIONS

Parameter	Test Conditions	Min.	Typ.	Max.	Units
Large Signal Voltage gain	Output Swing from 1 to 10V		70		dB
Gain Bandwidth Product, A-Amp		4.5			MHz
3dB BW, total loop		25			kHz
Phase Margin, A Amp		45			°
Slew Rate, A Amp			1.4	2	V/μs
Gain, B Amp		-1.17			*A gain
3dB Bandwidth, B		2.3			MHz
Total A+B saturation Resistance	I = 600mA		2	3	Ω
Offset reflected to I _{sense}	D/A reg @ 0			30	mV (1)
V _{pwr/2} Input Impedance	25°C	38	50	65	kΩ
Loopback Output Threshold (2)	25°C		50		mA/Ω
V _{sst} Saturated seek comparator threshold	Output saturated either polarity	30	50	70	mV

(1) Total current offset of VCM loop must not exceed 3% of full scale current.

(2) Optional.

CURRENT SENSE AMPLIFIER SPECIFICATIONS

Parameter	Test Conditions	Min.	Typ.	Max.	Units
Current Amp Gain	Over Temp	2.35	2.4	2.45	V/V
Available Output Current		±600			μA
Current Amp CMRR	Including inductive flyback range, to 25kHz	60			dB (1)

(1) Charge buildup on current amp input must not occur.

DAC SECTION SPECIFICATION

General Parameters

Parameter	Test Conditions	Min.	Typ.	Max.	Units
Differential Non linearity				1	LSB
Integral Non linearity	Best Fit			2	LSB
PSRR	10 - 14V	60			dB
Settle Time	90%		0.5	1.2	μs
Output Voltage Span	Vmin to Vmax		±2.5		V
Voltage Span Tolerance		-7		+7	%
Output Amp Impedance	full temp			5	Ω
Output Short cct Current	output shorted	1			mA
Coding	2's Complement				

PARK SECTION SPECIFICATIONS

Parameter	Test Conditions	Min.	Typ.	Max.	Units
Park Voltage		0.45	0.5	0.55	V

3.3V Voltage Regulator

VOLTAGE REGULATOR SPECIFICATIONS

Current Sense Comparator

Parameter	Test Conditions	Min.	Typ.	Max.	Units
DC Output Voltage	T _j = 0 to 160°C	3.135		+3.465	V
AC transient	1mA to full load			3%	of DC Out. Volt. (3)
Vilimit (1)	T _j = 0 to 160°C	0.24	0.3	0.36	V
Foldback Current Limit Ratio (2)	Output Shorted to Ground		3:1		Ratio

- (1) Vilimit is the voltage at which current limit begins to occur, as seen across Rcl (see block diagram) as measured by the UV detection occurring.
- (2) Foldback current limit prevents excessive power dissipation in the pass element under short circuit conditions. The ratio is the current flowing at current limit when the pass element under short circuit conditions. The ratio is the current flowing at current limit when the pass element is delivering full voltage (when UV first occurs), over the current in the pass element when the output is shorted to ground.
- (3) DC and AC transient requirements may be mixed, as long as the total deviation from 3.3V does not exceed Dvreg as specified under the critical specifications in section 6 of this specification.

DRIVER OUTPUT

Parameter	Test Conditions	Min.	Typ.	Max.	Units
Output Current	V _O < 3.5V			0.5	mA
Output High Voltage	I = -0.1mA, V = 5V	Vdd-2			V
Output Impedance	25°C			50	Ω

Operational Description

At power up, the regulator saturates the pass element until 3.3V is reached. If the 5V supply rises quickly, the regulator will current limit until 3.3V is reached. The initial current limit level is about 1/3 of the full voltage current limit level, to limit power dissipation in the pass element.

Once the 3.3V regulation level is reached, the regulator maintains this voltage regardless of load changes, even if the DOLPHIN goes into thermal

limit. Current limit provides a signal which also causes UV and a POR to occur.

If the 5V input is shut down before the 12V supply is removed, the pass element will drag down the 3.3V due to the internal diode. This prevents back biasing effects from occurring in the chips powered by the regulator.

Rgate (see block diagram) is provided to desensitize the pass element to layout problems.

In most applications it will not be needed.

Charge Pump

CHARGE PUMP SPECIFICATION

Parameter	Conditions	Min.	Typ.	Max.	Unit
Slew Rate	Run Mode			600	V/ μ s
RMS Current	All Conditions			400	mA
Peak Current	All Conditions			600	mA

APPLICATION NOTES AND REQUIREMENTS

Serial Port

GENERAL FORMAT REQUIREMENTS

1. Serial Port Packets must be sent without intervening data. The dead space between data bytes and after write packets addressed to this chip must be observed.
2. **Read:** A turnaround delay of 1 cycle minimum is expected on a read packet, between the address byte (written) and the first data byte read back. This is necessary only for data addressed directly to the combo, and is normally satisfied by the processor port turnaround requirements.
3. **Write:** Both bytes must be written to the serial port in rapid succession, disabling interrupts during the write period.
4. If the dead cycle between write packets to the DOLPHIN is not observed, an error will also occur. This is important at high data rates. (see manufacturer data specs).
5. Read: same as 4.

THERMAL SHUTDOWN

The serial port becomes inoperative during thermal shutdown. All data coming back is high. If the chip receives data words in which all bits are high, the chip is non-functional. This is invisible to the processor when compared with the thermal time constants and the detector hysteresis built into the chip.

Bit 3 of all registers is dedicated to thermal shutdown detection. If it is faster to check just a single bit rather than using a full compare, bit 3 is available in every read register.

NOTE: this was necessary in order to guarantee that all FF's would truly represent only a thermal shutdown situation.

VCM DRIVER

Software must set the VCM gain to 12:1 before enabling the VCM coil after spinup. A transient will occur while the amplifier slews up to its bias point. Allow a transient settle time of several microseconds before the VCM driver has settled to its fully enabled state.

SPINDLE DRIVER

Brake/Park

The register bits have been carefully arranged to allow the VCM software driver to run by looking only at the VCM control register. A register brake would normally be initiated by the spindle driver routine, by setting the register brake bit in the Aux Control Register. The Dolphin will then raise the park delay bit in the VCM Control Register, which the VCM driver can then use to indicate that a park has commenced. Thus, there is no need for the drivers to be directly linked through software flags. The register brake bit function has been changed to allow intermittent duty cycling during start mode, to supply additional damping. There are some restrictions on its use.

Back EMF Detection - Initialization

The back EMF detection in start differs from that in run. When transitioning from start to run, the first detected phase will always be the A negative crossing.

RESYNC ALGORITHM

The firmware must use start mode to resync the back EMF signal when attempting to resynchronize the spindle speed. Please consult the Motion Control Group for more details. The spinup algorithm is available as a separate specification.

DESIGN FORMULAS**Spindle startup current**

Spindle startup current is set up using the following formula:

$$I_{max} = R_{ref} \cdot \frac{1.6}{62.5k} \text{ in amps}$$

The Vcc tolerances are added to the final design value.

Back EMF window width

Window width is calculated for other than the nominal conditions by ratioing the window voltage against the current nominal design point:

$$tw = 25 \cdot \frac{R_{ref}}{R_{ref} + R_{ref}} \cdot \frac{62.5 + 120}{62.5} \cdot \frac{8V}{V_{emf}} \cdot \frac{6000}{RPM}$$

Where:

Vemf is the nominal expected back emf to peak voltage, RPM is the target RPM of the drive;

tw is the resultant window width.

If the window is too small or too large, transients will affect the detection.

CHOPPING WAVEFORM

There is a requirement on the back EMF waveform. The chopping transients must die out before the waveform is sampled or speed errors will result.

This puts limits on the damping resistors if present, which depend on motor inductance, eddy current losses and the like.

SH_OUT COMPONENTS

The SH_Out components must be designed so that the rate of droop of the capacitor matches the back EMF waveform at its negative going zero crossing point when the drive is on speed. Components for one part will work for the other part, but voltage waveforms are scaled differently between the two parts.

The SH_Out resistor should be as large as possible. This minimizes the internal impedances and sample/hold errors. 100K is the nominal design point.

Additional design formulas are included in the applications notes for each vendor's parts and in Western Digital's internal application notes.

PLCC44 PACKAGE MECHANICAL DATA

DIM.	mm			inch		
	MIN.	TYP.	MAX.	MIN.	TYP.	MAX.
A	17.4		17.65	0.685		0.695
B	16.51		16.65	0.650		0.656
C	3.65		3.7	0.144		0.146
D	4.2		4.57	0.165		0.180
d1	2.59		2.74	0.102		0.108
d2		0.68			0.027	
E	14.99		16	0.590		0.630
e		1.27			0.050	
e3		12.7			0.500	
e4			1.98			0.078
F		0.46			0.018	
F1		0.71			0.028	
G			0.101			0.004
M		1.16			0.046	
M1		1.14			0.045	

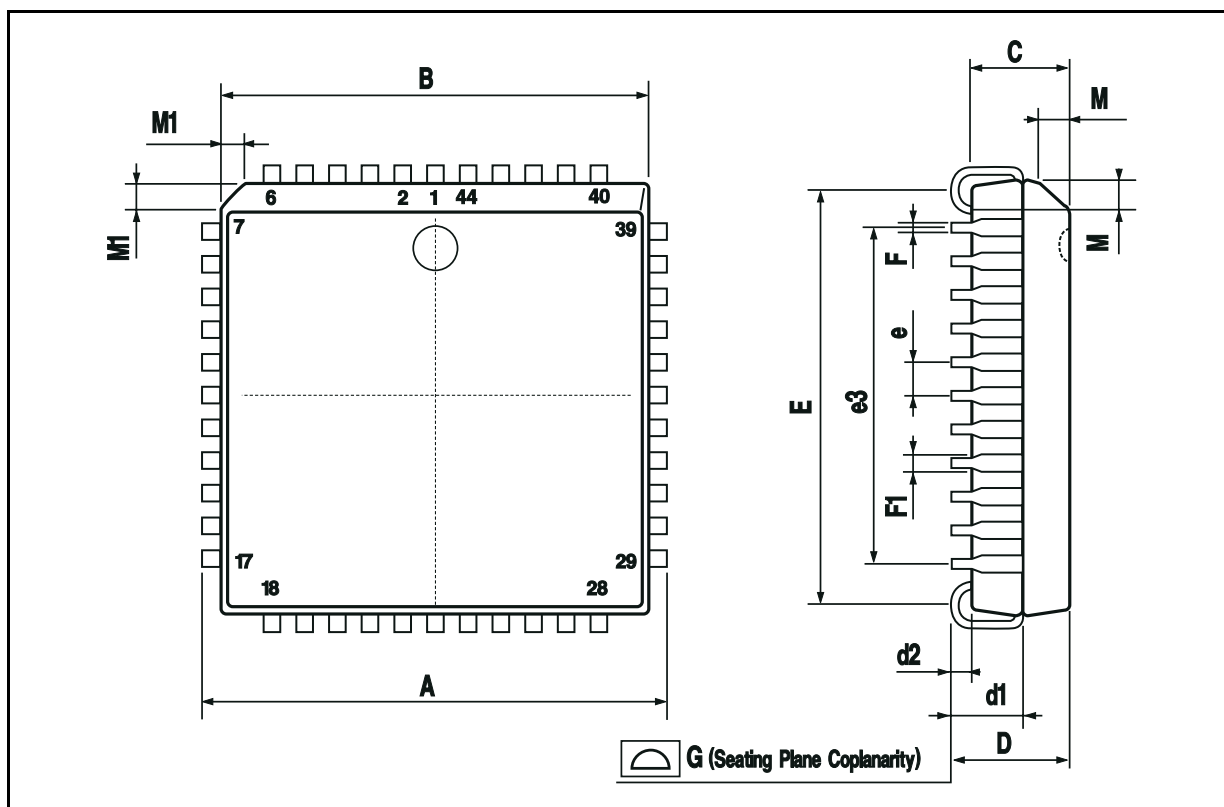

Information furnished is believed to be accurate and reliable. However, SGS-THOMSON Microelectronics assumes no responsibility for the consequences of use of such information nor for any infringement of patents or other rights of third parties which may result from its use. No license is granted by implication or otherwise under any patent or patent rights of SGS-THOMSON Microelectronics. Specification mentioned in this publication are subject to change without notice. This publication supersedes and replaces all information previously supplied. SGS-THOMSON Microelectronics products are not authorized for use as critical components in life support devices or systems without express written approval of SGS-THOMSON Microelectronics.

© 1997 SGS-THOMSON Microelectronics – Printed in Italy – All Rights Reserved

SGS-THOMSON Microelectronics GROUP OF COMPANIES

Australia - Brazil - Canada - China - France - Germany - Hong Kong - Italy - Japan - Korea - Malaysia - Malta - Morocco - The Netherlands - Singapore - Spain - Sweden - Switzerland - Taiwan - Thailand - United Kingdom - U.S.A.