

Features

- Very high speed: 55 ns
- Wide voltage range: 1.65V–2.25V
- Pin compatible with CY62147DV18
- Ultra low standby power
 - Typical standby current: 1 μ A
 - Maximum standby current: 7 μ A
- Ultra low active power
 - Typical active current: 2 mA @ f = 1 MHz
- Ultra low standby power
- Easy memory expansion with CE and OE features
- Automatic power down when deselected
- CMOS for optimum speed and power
- Available in a Pb-free 48-Ball VFBGA package

Functional Description

The CY62147EV18 is a high performance CMOS static RAM organized as 256K words by 16 bits. This device features advanced circuit design to provide ultra low active current. This is ideal for providing More Battery Life™ (MoBL®) in portable applications such as cellular telephones. The device also has an automatic power down feature that significantly reduces power

consumption when addresses are not toggling. Placing the device into standby mode reduces power consumption by more than 99% when deselected (\overline{CE} HIGH or both \overline{BLE} and \overline{BHE} are HIGH). The input and output pins (IO_0 through IO_{15}) are placed in a high impedance state when:

- Deselected (\overline{CE} HIGH)
- Outputs are disabled (\overline{OE} HIGH)
- Both Byte High Enable and Byte Low Enable are disabled (\overline{BHE} , \overline{BLE} HIGH)
- When a write operation is active (\overline{CE} LOW and \overline{WE} LOW).

To write to the device, take Chip Enable (\overline{CE}) and Write Enable (\overline{WE}) inputs LOW. If Byte Low Enable (\overline{BLE}) is LOW then data from IO pins (IO_0 through IO_7) is written into the location specified on the address pins (A_0 through A_{17}). If Byte High Enable (\overline{BHE}) is LOW, then data from IO pins (IO_8 through IO_{15}) is written into the location specified on the address pins (A_0 through A_{17}).

To read from the device, take Chip Enable (\overline{CE}) and Output Enable (\overline{OE}) LOW while forcing the Write Enable (\overline{WE}) HIGH. If Byte Low Enable (\overline{BLE}) is LOW, then data from the memory location specified by the address pins appears on IO_0 to IO_7 . If Byte High Enable (\overline{BHE}) is LOW, then data from memory appears on IO_8 to IO_{15} . See the "Truth Table" on page 9 for a complete description of read and write modes.

For best practice recommendations, refer to the Cypress application note [AN1064, SRAM System Guidelines](#).

Logic Block Diagram

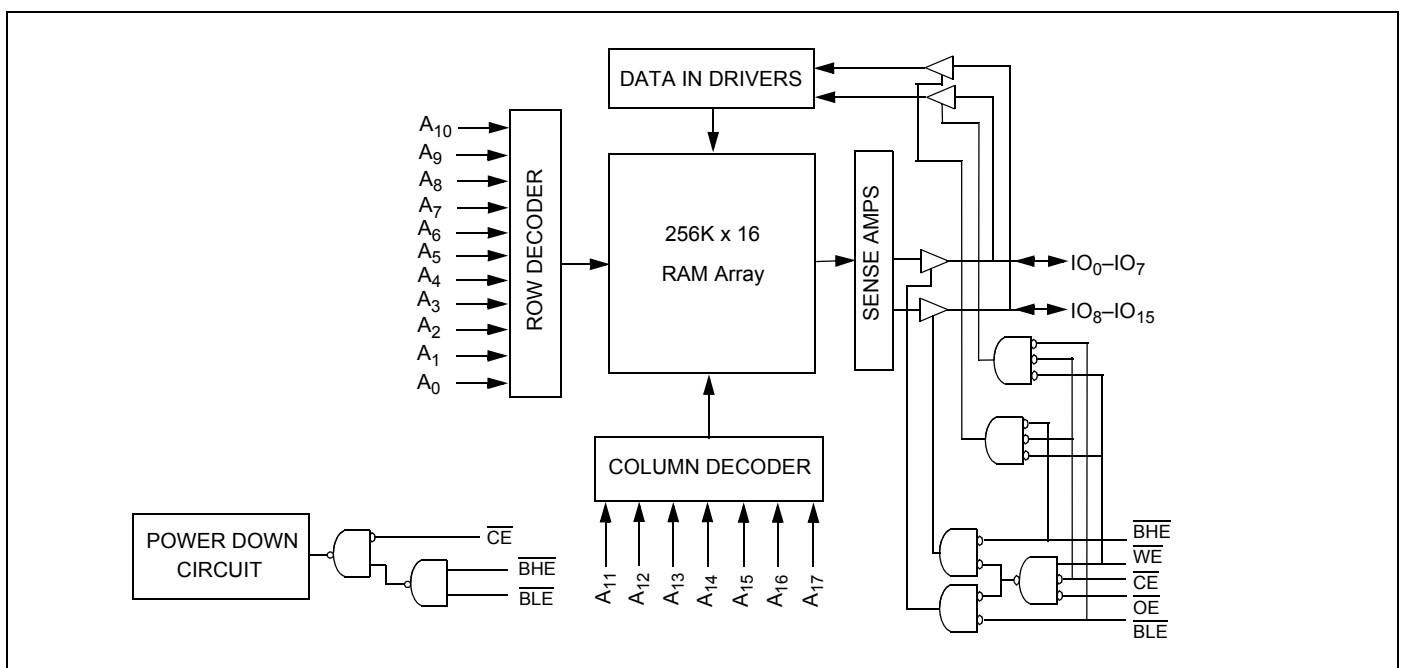

Product Portfolio

Product	V _{CC} Range (V)			Speed (ns)	Power Dissipation					
					Operating I _{CC} (mA)				Standby I _{SB2} (μA)	
					f = 1MHz		f = f _{max}			
Min	Typ ^[1]	Max	Typ ^[1]	Max	Typ ^[1]	Max	Typ ^[1]	Max		
CY62147EV18LL	1.65	1.8	2.25	55	2	2.5	15	20	1	7

Pin Configuration

Figure 1. 48-Ball VFBGA Pinout^[2, 3]

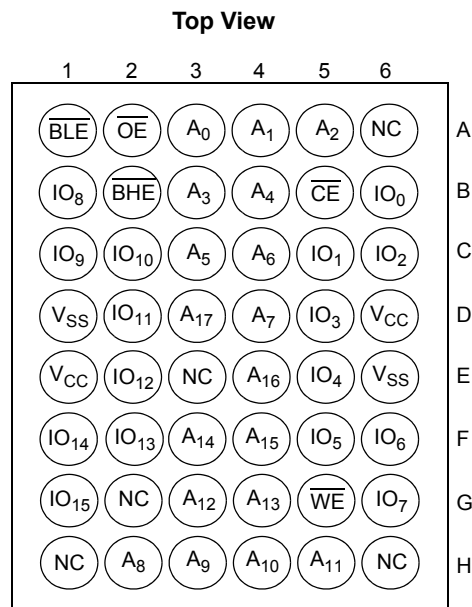

Notes

1. Typical values are included for reference only and are not guaranteed or tested. Typical values are measured at V_{CC} = V_{CC(typ)}, T_A = 25°C.
2. NC pins are not connected on the die.
3. Pins H1, G2, and H6 in the VFBGA package are address expansion pins for 8 Mb, 16 Mb and 32 Mb, respectively.



Maximum Ratings

Exceeding the maximum ratings may shorten the battery life of the device. User guidelines are not tested.

Storage Temperature -65°C to + 150°C

Ambient Temperature with Power Applied -55°C to + 125°C

Supply Voltage to Ground Potential -0.2V to + 2.45V ($V_{CCmax} + 0.2V$)

DC Voltage Applied to Outputs in High Z State^[4, 5] -0.2V to 2.45V ($V_{CCmax} + 0.2V$)

DC Input Voltage^[4, 5] -0.2V to 2.45V ($V_{CCmax} + 0.2V$)

Output Current into Outputs (LOW) 20 mA

Static Discharge Voltage > 2001V (MIL-STD-883, Method 3015)

Latch up Current > 200 mA

Operating Range

Device	Range	Ambient Temperature	V_{CC} ^[6]
CY62147EV18LL	Industrial	-40°C to +85°C	1.65V to 2.25V

Electrical Characteristics

Over the Operating Range

Parameter	Description	Test Conditions	55 ns			Unit
			Min	Typ ^[1]	Max	
V_{OH}	Output HIGH Voltage	$I_{OH} = -0.1 \text{ mA}$	1.4			V
V_{OL}	Output LOW Voltage	$I_{OL} = 0.1 \text{ mA}$			0.2	V
V_{IH}	Input HIGH Voltage	$V_{CC} = 1.65V \text{ to } 2.25V$	1.4		$V_{CC} + 0.2$	V
V_{IL}	Input LOW Voltage	$V_{CC} = 1.65V \text{ to } 2.25V$	-0.2		0.4	V
I_{IX}	Input Leakage Current	$GND \leq V_I \leq V_{CC}$	-1		+1	μA
I_{OZ}	Output Leakage Current	$GND \leq V_O \leq V_{CC}$, Output Disabled	-1		+1	μA
I_{CC}	V_{CC} Operating Supply Current	$f = f_{max} = 1/t_{RC}$		15	20	mA
		$V_{CC(max)} = 2.25V$ $I_{OUT} = 0 \text{ mA}$ CMOS levels				
		$f = 1 \text{ MHz}$		2	2.5	mA
I_{SB1}	Automatic CE Power Down Current—CMOS Inputs	$\overline{CE} \geq V_{CC} - 0.2V$, $V_{IN} \geq V_{CC} - 0.2V$, $V_{IN} \leq 0.2V$ $f = f_{max}$ (Address and Data Only), $f = 0$ (OE, WE, BHE, and BLE)		1	7	μA
I_{SB2} ^[7]	Automatic CE Power Down Current—CMOS Inputs	$\overline{CE} \geq V_{CC} - 0.2V$, $V_{IN} \geq V_{CC} - 0.2V$ or $V_{IN} \leq 0.2V$, $f = 0$		1	7	μA

Capacitance

Tested initially and after any design or process changes that may affect these parameters.

Parameter	Description	Test Conditions	Max	Unit
C_{IN}	Input Capacitance	$T_A = 25^\circ\text{C}$, $f = 1 \text{ MHz}$, $V_{CC} = V_{CC(typ)}$	10	pF
C_{OUT}	Output Capacitance		10	pF

Notes

- $V_{IL(min)}$ = -2.0V for pulse durations less than 20 ns.
- $V_{IH(max)}$ = $V_{CC} + 0.5V$ for pulse durations less than 20 ns.
- Full device AC operation assumes a minimum of 100 μs ramp time from 0 to $V_{CC(min)}$ and 200 μs wait time after V_{CC} stabilization.
- Only chip enable (CE) and byte enables (BHE and BLE) need to be tied to CMOS levels to meet the I_{SB2} / I_{CCDR} spec. Other inputs can be left floating.

Thermal Resistance

Tested initially and after any design or process changes that may affect these parameters.

Parameter	Description	Test Conditions	VFBGA Package	Unit
Θ_{JA}	Thermal Resistance (Junction to Ambient)	Still air, soldered on a 3 × 4.5 inch, two-layer printed circuit board	75	°C/W
Θ_{JC}	Thermal Resistance (Junction to Case)		10	°C/W

AC Test Loads and Waveforms

Figure 2. AC Test Loads and Waveforms

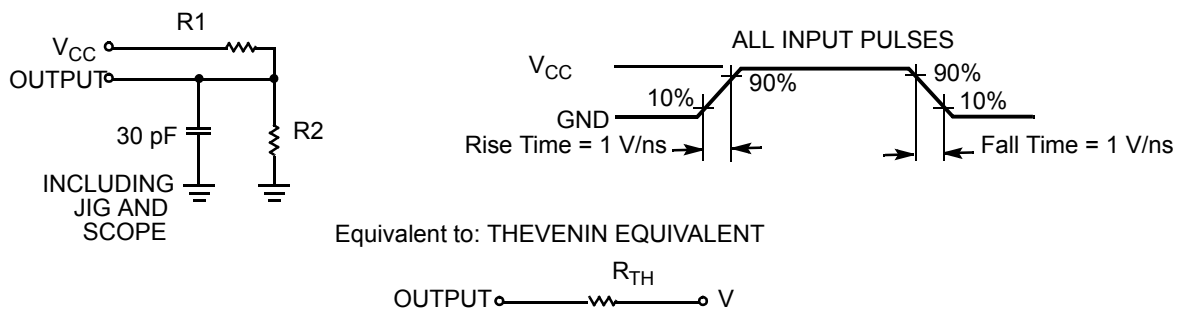

Parameters	1.80V	Unit
R1	13500	Ω
R2	10800	Ω
R_{TH}	6000	Ω
V_{TH}	0.80	V

Data Retention Characteristics

Over the Operating Range

Parameter	Description	Conditions	Min	Typ ^[1]	Max	Unit
V_{DR}	V_{CC} for Data Retention		1.0			V
$I_{CCDR}^{[7]}$	Data Retention Current	$V_{CC} = 1.0V, \overline{CE} \geq V_{CC} - 0.2V,$ $V_{IN} \geq V_{CC} - 0.2V$ or $V_{IN} \leq 0.2V$		0.5	5	μA
$t_{CDR}^{[8]}$	Chip Deselect to Data Retention Time		0			ns
$t_R^{[9]}$	Operation Recovery Time		t_{RC}			ns

Data Retention Waveform

Figure 3. Data Retention Waveform^[10]

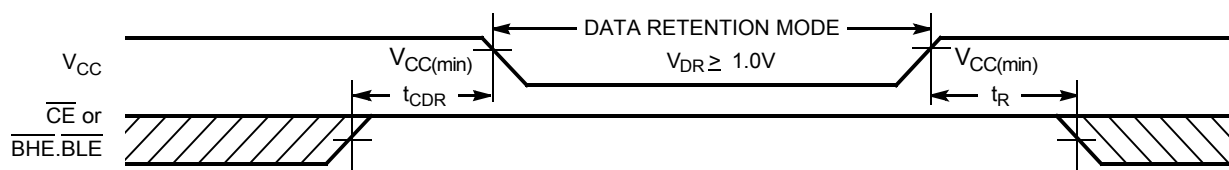

Notes

- 8. Tested initially and after any design or process changes that may affect these parameters.
- 9. Full device operation requires linear V_{CC} ramp from V_{DR} to $V_{CC(min)} \geq 100 \mu s$ or stable at $V_{CC(min)} \geq 100 \mu s$.
- 10. $\overline{BHE.BLE}$ is the AND of both \overline{BHE} and \overline{BLE} . Deselect the chip by either disabling chip enable signals or by disabling both \overline{BHE} and \overline{BLE} .

Switching Characteristics

Over the Operating Range ^[11, 12]

Parameter	Description	55 ns		Unit
		Min	Max	
Read Cycle				
t _{RC}	Read Cycle Time	55		ns
t _{AA}	Address to Data Valid		55	ns
t _{OHA}	Data Hold from Address Change	10		ns
t _{ACE}	\overline{CE} LOW to Data Valid		55	ns
t _{DOE}	\overline{OE} LOW to Data Valid		25	ns
t _{LZOE}	\overline{OE} LOW to Low Z ^[13]	5		ns
t _{HZOE}	\overline{OE} HIGH to High Z ^[13, 14]		18	ns
t _{LZCE}	\overline{CE} LOW to Low Z ^[13]	10		ns
t _{HZCE}	\overline{CE} HIGH to High Z ^[13, 14]		18	ns
t _{PU}	\overline{CE} LOW to Power Up	0		ns
t _{PD}	\overline{CE} HIGH to Power Down		55	ns
t _{DBE}	$\overline{BLE}/\overline{BHE}$ LOW to Data Valid		55	ns
t _{LZBE}	$\overline{BLE}/\overline{BHE}$ LOW to Low Z ^[13]	10		ns
t _{HZBE}	$\overline{BLE}/\overline{BHE}$ HIGH to High Z ^[13, 14]		18	ns
Write Cycle^[15]				
t _{WC}	Write Cycle Time	45		ns
t _{SCE}	\overline{CE} LOW to Write End	35		ns
t _{AW}	Address Setup to Write End	35		ns
t _{HA}	Address Hold from Write End	0		ns
t _{SA}	Address Setup to Write Start	0		ns
t _{PWE}	\overline{WE} Pulse Width	35		ns
t _{BW}	$\overline{BLE}/\overline{BHE}$ LOW to Write End	35		ns
t _{SD}	Data Setup to Write End	25		ns
t _{HD}	Data Hold from Write End	0		ns
t _{HZWE}	\overline{WE} LOW to High Z ^[13, 14]		18	ns
t _{LZWE}	\overline{WE} HIGH to Low Z ^[13]	10		ns

Notes

- 11. Test conditions for all parameters other than tri-state parameters assume signal transition time of 1V/ns or less, timing reference levels of V_{CC(typ)}/2, input pulse levels of 0 to V_{CC(typ)}, and output loading of the specified I_{OL}/I_{OH} as shown in the "AC Test Loads and Waveforms" on page 4 section.
- 12. AC timing parameters are subject to byte enable signals (BHE or BLE) not switching when chip is disabled. See application note AN13842 for further clarification.
- 13. At any temperature and voltage condition, t_{HZCE} is less than t_{LZCE}, t_{HZBE} is less than t_{LZBE}, t_{HZOE} is less than t_{LZOE}, and t_{HZWE} is less than t_{LZWE} for any device.
- 14. t_{HZOE}, t_{HZCE}, t_{HZBE}, and t_{HZWE} transitions are measured when the output enters a high impedance state
- 15. The internal write time of the memory is defined by the overlap of WE, CE = V_{IL}, BHE, BLE or both = V_{IL}. All signals must be active to initiate a write and any of these signals can terminate a write by going inactive. The data input setup and hold timing must be referenced to the edge of the signal that terminates the write.

Switching Waveforms

Figure 4 shows the Read Cycle No.1 that is address transition controlled. [16, 17]

Figure 4. Read Cycle No. 1

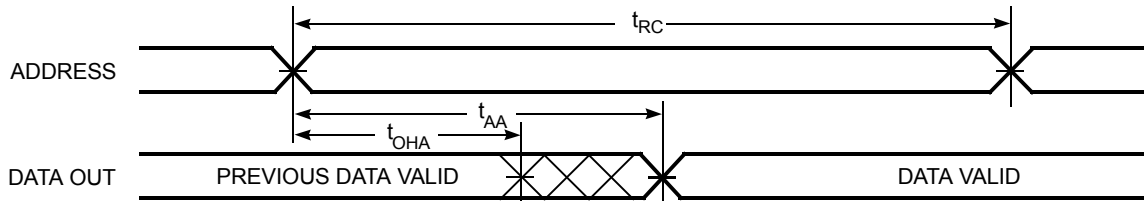
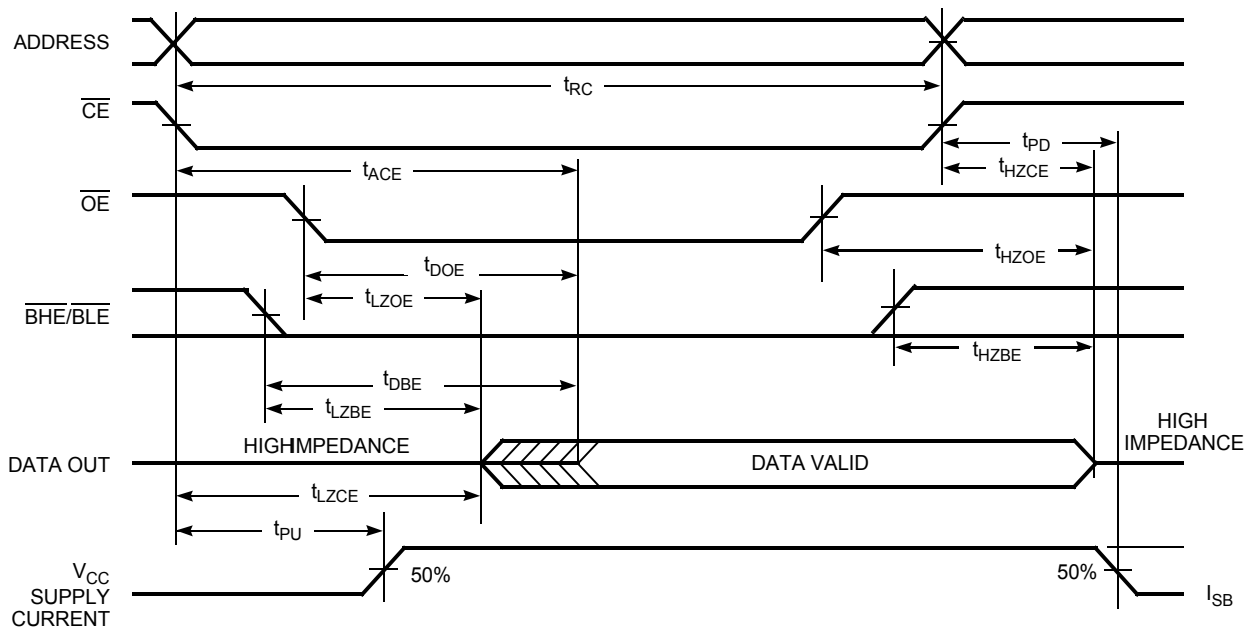

Figure 5 shows the Read Cycle No.2 that is \overline{OE} controlled. [17, 18]

Figure 5. Read Cycle No. 2



Notes:

- 16. The device is continuously selected. \overline{OE} , \overline{CE} = V_{IL} , \overline{BHE} , \overline{BLE} or both = V_{IL} .
- 17. \overline{WE} is HIGH for read cycle.
- 18. Address valid before or similar to \overline{CE} and \overline{BHE} , \overline{BLE} transition LOW.

Switching Waveforms (continued)

Figure 6 shows the Write Cycle No.1 that is \overline{WE} Controlled. [15, 19, 20]

Figure 6. Write Cycle No. 1

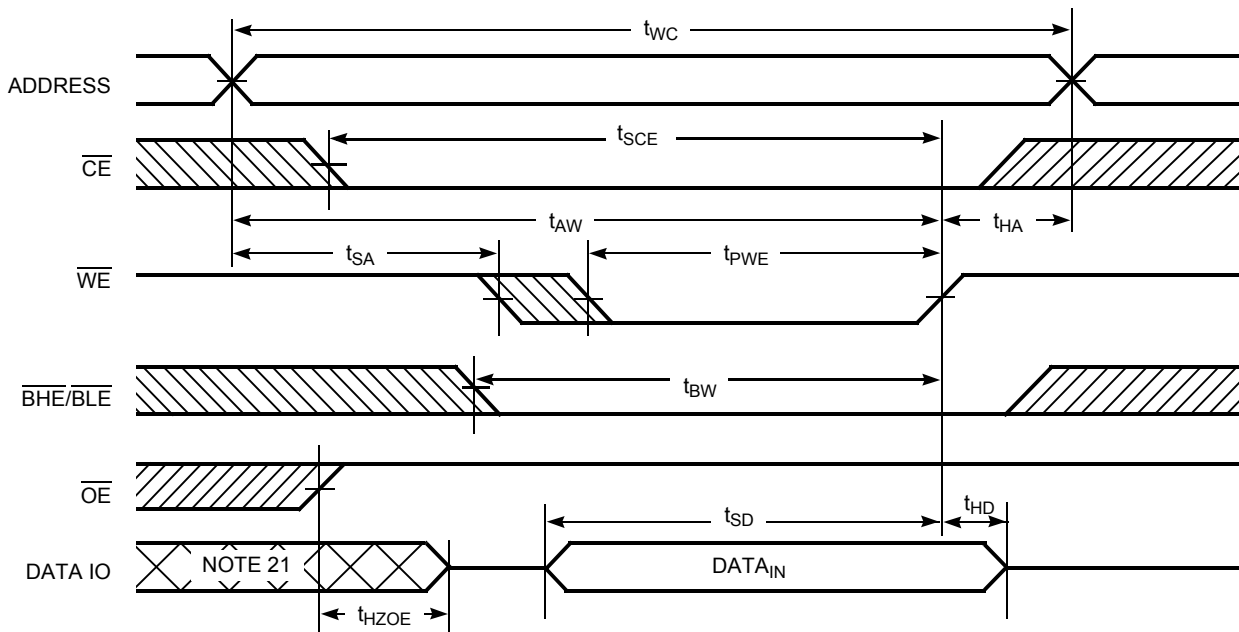
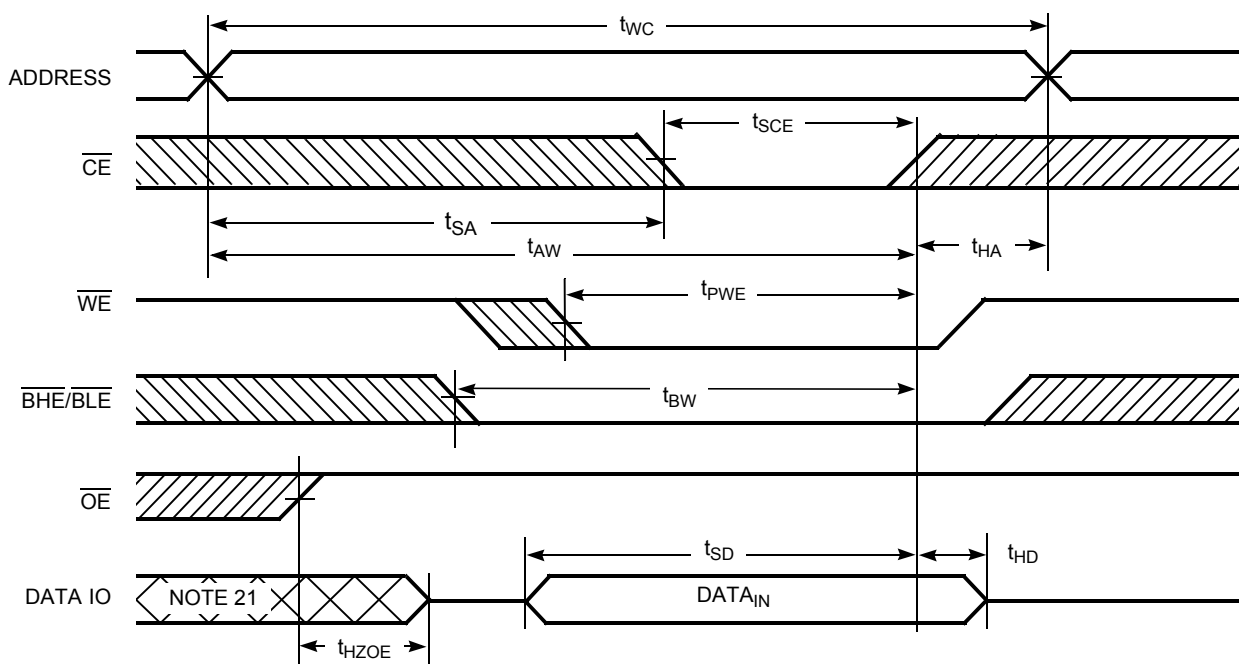

Figure 7 shows the Write Cycle No.2 that is \overline{CE} Controlled. [15, 19, 20]

Figure 7. Write Cycle No. 2



Notes:

- 19. Data IO is high impedance if $\overline{OE} = V_{IH}$.
- 20. If \overline{CE} goes HIGH simultaneously with $\overline{WE} = V_{IH}$, the output remains in a high impedance state.
- 21. During this period, the IOs are in output state. Do not apply input signals.

Switching Waveforms (continued)

Figure 8 shows the Write Cycle No. 3 that is \overline{WE} Controlled and \overline{OE} LOW. [20]

Figure 8. Write Cycle No. 3

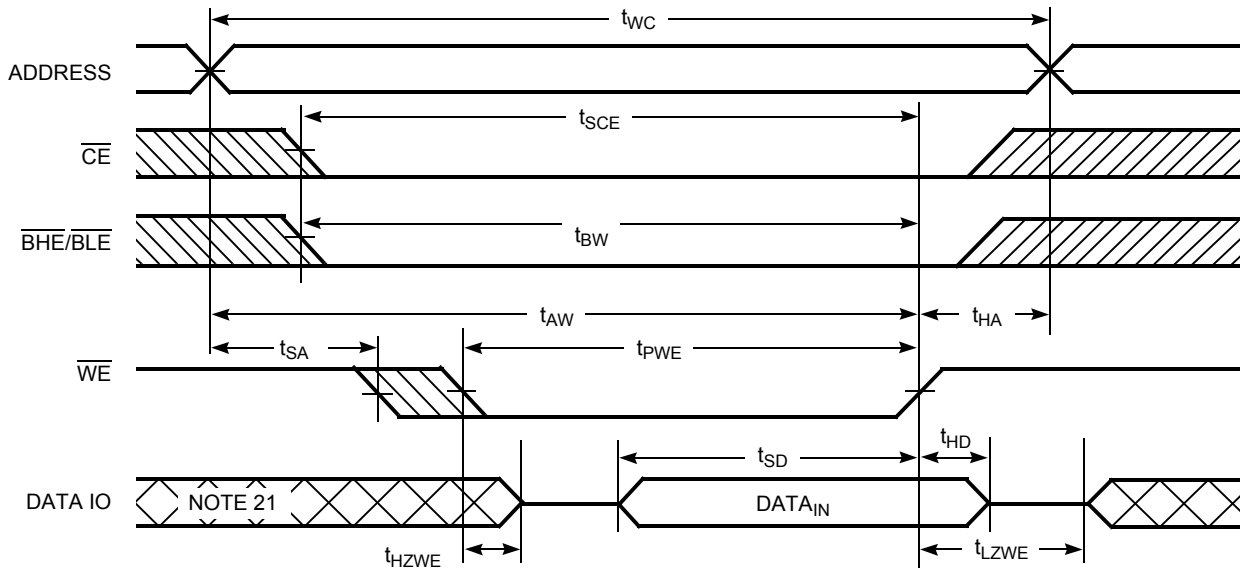
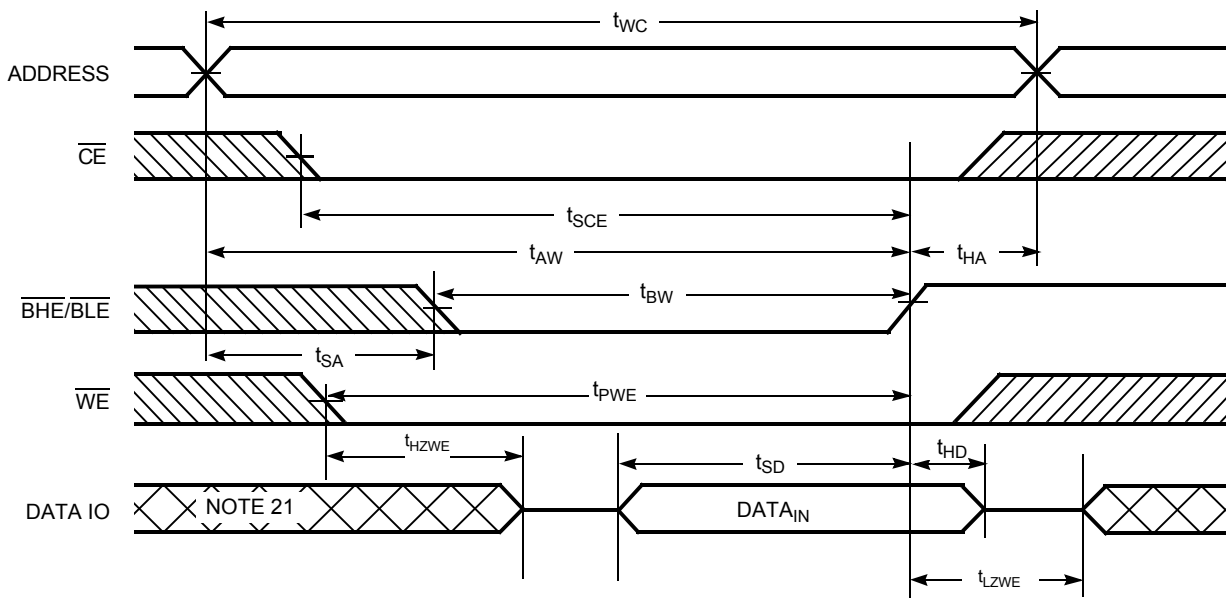

Figure 9 shows Write Cycle No. 4 that is $\overline{BHE/BLE}$ Controlled and \overline{OE} LOW. [20]

Figure 9. Write Cycle No. 4



Truth Table

$\overline{\text{CE}}$	$\overline{\text{WE}}$	$\overline{\text{OE}}$	$\overline{\text{BHE}}$	$\overline{\text{BLE}}$	Inputs or Outputs	Mode	Power
H	X	X	X	X	High Z	Deselect or Power Down	Standby (I_{SB})
L	X	X	H	H	High Z	Deselect or Power Down	Standby (I_{SB})
L	H	L	L	L	Data Out ($\text{IO}_0\text{--}\text{IO}_{15}$)	Read	Active (I_{CC})
L	H	L	H	L	Data Out ($\text{IO}_0\text{--}\text{IO}_7$); $\text{IO}_8\text{--}\text{IO}_{15}$ in High-Z	Read	Active (I_{CC})
L	H	L	L	H	Data Out ($\text{IO}_8\text{--}\text{IO}_{15}$); $\text{IO}_0\text{--}\text{IO}_7$ in High-Z	Read	Active (I_{CC})
L	H	H	L	L	High Z	Output Disabled	Active (I_{CC})
L	H	H	H	L	High Z	Output Disabled	Active (I_{CC})
L	H	H	L	H	High Z	Output Disabled	Active (I_{CC})
L	L	X	L	L	Data In ($\text{IO}_0\text{--}\text{IO}_{15}$)	Write	Active (I_{CC})
L	L	X	H	L	Data In ($\text{IO}_0\text{--}\text{IO}_7$); $\text{IO}_8\text{--}\text{IO}_{15}$ in High-Z	Write	Active (I_{CC})
L	L	X	L	H	Data In ($\text{IO}_8\text{--}\text{IO}_{15}$); $\text{IO}_0\text{--}\text{IO}_7$ in High-Z	Write	Active (I_{CC})

Ordering Information

Speed (ns)	Ordering Code	Package Diagram	Package Type	Operating Range
55	CY62147EV18LL-55BVXI	51-85150	48-Ball VFBGA (Pb-free)	Industrial

Contact your local Cypress sales representative for availability of other parts.

Package Diagram

Figure 10. 48-Ball VFBGA (6 x 8 x 1 mm), 51- 85150

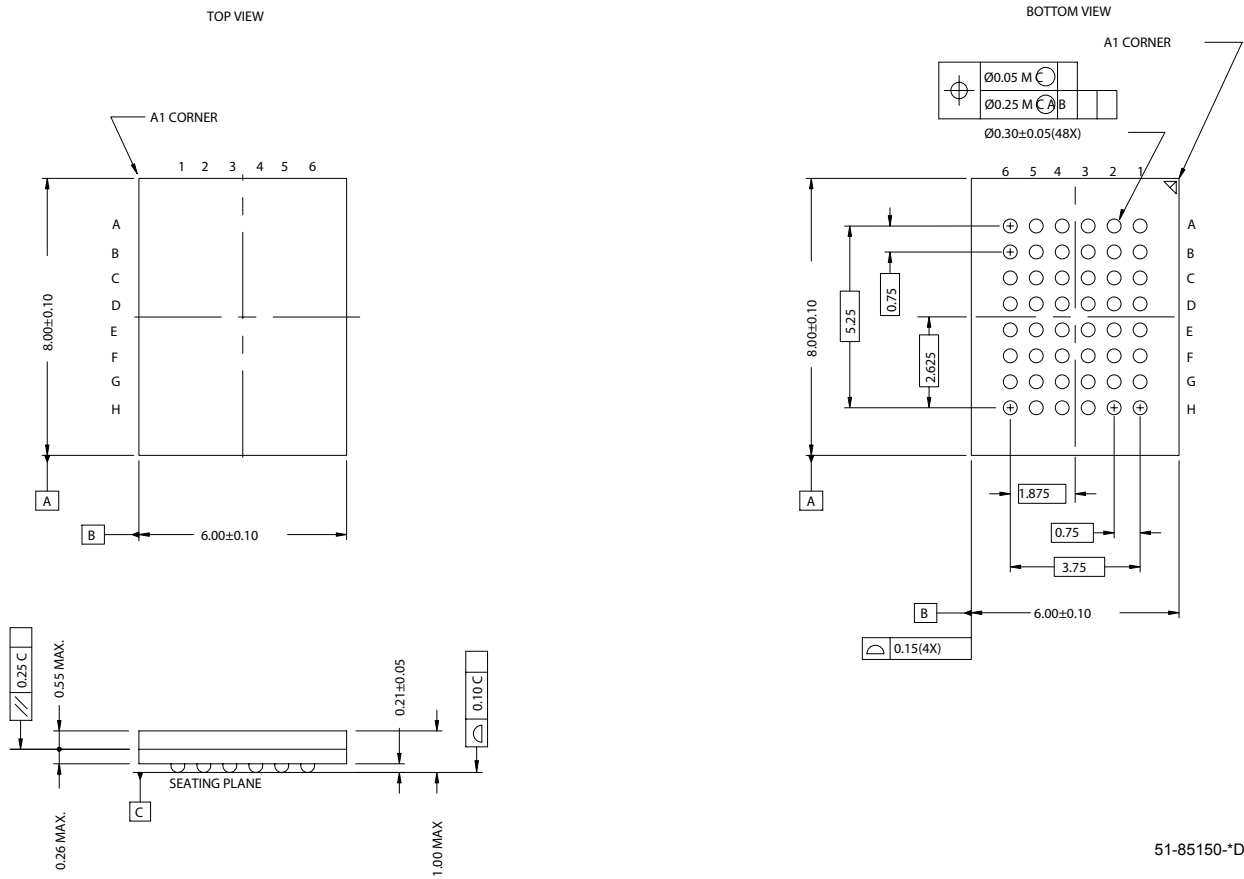

51-85150-D

Document History Page

Document Title: CY62147EV18 MoBL2™ 4-Mbit (256K x 16) Static RAM Document Number: 38-05441				
REV.	ECN NO.	Issue Date	Orig. of Change	Description of Change
**	201580	01/08/04	AJU	New Datasheet
*A	247009	See ECN	SYT	<p>Changed from Advance Information to Preliminary</p> <p>Moved Product Portfolio to Page 2</p> <p>Changed V_{CCMax} from 2.20 to 2.25 V</p> <p>Changed V_{CC} stabilization time in footnote #8 from 100 μs to 200 μs</p> <p>Removed Footnote #15 (t_{LZBE}) from Previous Revision</p> <p>Changed I_{CCDR} from 2.0 μA to 2.5 μA</p> <p>Changed typo in Data Retention Characteristics (t_R) from 100 μs to t_{RC} ns</p> <p>Changed t_{OHA} from 6 ns to 10 ns for both 35 ns and 45 ns Speed Bin</p> <p>Changed t_{HZOE}, t_{HZBE}, t_{HZWE} from 12 to 15 ns for 35 ns Speed Bin and 15 to 18 ns for 45 ns Speed Bin</p> <p>Changed t_{SCE} and t_{BW} from 25 to 30 ns for 35 ns Speed Bin and 40 to 35 ns for 45 ns Speed Bin</p> <p>Changed t_{HZCE} from 12 to 18 ns for 35 ns Speed Bin and 15 to 22 ns for 45 ns Speed Bin</p> <p>Changed t_{SD} from 15 to 18 ns for 35 ns Speed Bin and 20 to 22 ns for 45 ns Speed Bin</p> <p>Changed t_{DOE} from 15 to 18 ns for 35 ns Speed Bin</p> <p>Changed Ordering Information to include Pb-Free Packages</p>
*B	414820	See ECN	ZSD	<p>Changed from Preliminary to Final</p> <p>Changed the address of Cypress Semiconductor Corporation on Page #1 from "3901 North First Street" to "198 Champion Court"</p> <p>Removed 35 ns Speed Bin</p> <p>Removed "L" version of CY62147EV18</p> <p>Changed ball E3 from DNU to NC</p> <p>Changed $I_{CC}(typ)$ value from 1.5 mA to 2 mA at $f = 1$ MHz</p> <p>Changed $I_{CC}(max)$ value from 2 mA to 2.5 mA at $f = 1$ MHz</p> <p>Changed $I_{CC}(typ)$ value from 12 mA to 15 mA at $f = f_{max}$</p> <p>Changed I_{SB1} and I_{SB2} Typ values from 0.7 μA to 1 μA and Max values from 2.5 μA to 7 μA</p> <p>Extended undershoot limit to -2V in footnote #5</p> <p>Changed I_{CCDR} Max from 2.5 μA to 3 μA</p> <p>Added I_{CCDR} typical value</p> <p>Changed t_{LZOE} from 3 ns to 5 ns</p> <p>Changed t_{LZCE}, t_{LZBE} and t_{LZWE} from 6 ns to 10 ns</p> <p>Changed t_{HZCE} from 22 ns to 18 ns</p> <p>Changed t_{PWE} from 30 ns to 35 ns</p> <p>Changed t_{SD} from 22 ns to 25 ns</p> <p>Updated the package diagram 48-pin VFBGA from *B to *D</p> <p>Updated the ordering information table and replaced Package Name Column with Package Diagram</p>
*C	571786	See ECN	VKN	Replaced 45ns speed bin with 55 ns
*D	908120	See ECN	VKN	<p>Added footnote #8 related to I_{SB2} and I_{CCDR}</p> <p>Added footnote #13 related AC timing parameters</p> <p>Changed t_{WC} specification from 45 ns to 55 ns</p> <p>Changed t_{SCE}, t_{AW}, t_{PWE}, t_{BW} spec from 35 ns to 40 ns</p> <p>Changed t_{HZWE} specification from 18 ns to 20 ns</p>



Document Title: CY62147EV18 MoBL2™ 4-Mbit (256K x 16) Static RAM				
Document Number: 38-05441				
REV.	ECN NO.	Issue Date	Orig. of Change	Description of Change
*E	1045701	See ECN	VKN	Changed I _{CCDR} specification from 3 μA to 5 μA
*F	1274728	See ECN	VKN/AESA	Changed t _{WC} specification from 55 ns to 45 ns Changed t _{SCE} , t _{AW} , t _{PWE} , t _{BW} specification from 40 ns to 35 ns Changed t _{HZWE} specification from 20 ns to 18 ns

© Cypress Semiconductor Corporation, 2004-2007. The information contained herein is subject to change without notice. Cypress Semiconductor Corporation assumes no responsibility for the use of any circuitry other than circuitry embodied in a Cypress product. Nor does it convey or imply any license under patent or other rights. Cypress products are not warranted nor intended to be used for medical, life support, life saving, critical control or safety applications, unless pursuant to an express written agreement with Cypress. Furthermore, Cypress does not authorize its products for use as critical components in life-support systems where a malfunction or failure may reasonably be expected to result in significant injury to the user. The inclusion of Cypress products in life-support systems application implies that the manufacturer assumes all risk of such use and in doing so indemnifies Cypress against all charges.

Any Source Code (software and/or firmware) is owned by Cypress Semiconductor Corporation (Cypress) and is protected by and subject to worldwide patent protection (United States and foreign), United States copyright laws and international treaty provisions. Cypress hereby grants to licensee a personal, non-exclusive, non-transferable license to copy, use, modify, create derivative works of, and compile the Cypress Source Code and derivative works for the sole purpose of creating custom software and/or firmware in support of licensee product to be used only in conjunction with a Cypress integrated circuit as specified in the applicable agreement. Any reproduction, modification, translation, compilation, or representation of this Source Code except as specified above is prohibited without the express written permission of Cypress.

Disclaimer: CYPRESS MAKES NO WARRANTY OF ANY KIND, EXPRESS OR IMPLIED, WITH REGARD TO THIS MATERIAL, INCLUDING, BUT NOT LIMITED TO, THE IMPLIED WARRANTIES OF MERCHANTABILITY AND FITNESS FOR A PARTICULAR PURPOSE. Cypress reserves the right to make changes without further notice to the materials described herein. Cypress does not assume any liability arising out of the application or use of any product or circuit described herein. Cypress does not authorize its products for use as critical components in life-support systems where a malfunction or failure may reasonably be expected to result in significant injury to the user. The inclusion of Cypress' product in a life-support systems application implies that the manufacturer assumes all risk of such use and in doing so indemnifies Cypress against all charges.

Use may be limited by and subject to the applicable Cypress software license agreement.