

iC-RC1000

SIN/COS SIGNAL SAFETY MONITOR IC

FEATURES

- Sine/cosine encoder signal monitoring for SIL applications
- Suitable for differential encoder signals of 1 Vpp (250 mV amplitude per line)
- Suitable for single-ended signals (500 mV amplitude per line)
- Monitor for input frequencies from 0 to 500 kHz
- Verification of DC common mode range per signal line
- Monitoring of Lissajous curve with min/max limits
- Cable fracture detection
- Source decoupling and overvoltage clamping per pin by external resistors
- Single-failure-proof dual channel concept
- Independent diagnostic outputs:
signal OK message and signal error message

APPLICATIONS

- Sensor monitoring
- Motion control
- Functional safety

PACKAGES

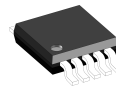

MSOP10

BLOCK DIAGRAM

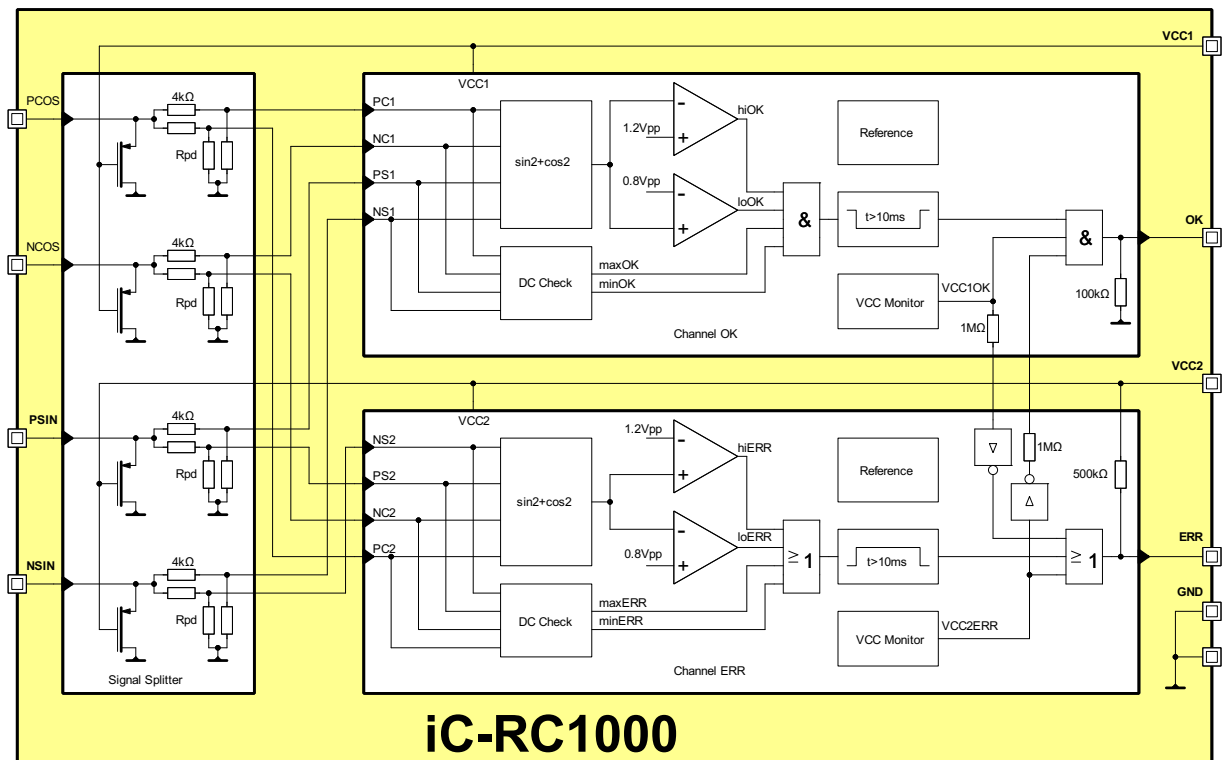

iC-RC1000

SIN/COS SIGNAL SAFETY MONITOR IC

preliminary



Rev A2, Page 2/10

DESCRIPTION

iC-RC1000 acts as an independent monitoring device for industrial safety controllers and drive systems in the evaluation of sine encoders for SIL applications.

In this function the IC checks that four analog signal lines have the correct DC voltage range (DC range: 30 to 80 % from VCC1 or VCC2) and that two respective paired lines have the correct differential 1 Vpp signal amplitude in real time (amplitude range: 200 to 300 mV). Signals with twice this amplitude (400 to 600 mV) referenced to ground can also be monitored; here, the negative input must be kept within the permissible DC range (e.g. VCC/2).

iC-RC1000 has intrinsic safety, enabling single errors to be securely identified through redundancy; independently of one another, two different diagnostic channels monitor the input signals, outputting separate messages. The Signal OK and the Signal error statuses are complementary to one another if the chip is functioning correctly.

Each diagnostic channel has signal comparators for DC and square sum monitoring; the monitoring windows have a different design depending on the good/bad diagnosis. The square sum monitor uses an analog multiplier and calculates the Lissajous curve derived from the square signal by the sine and cosine ($\sin(\omega t)^2 + \cos(\omega t)^2$).

So that the external controller can safely detect an interrupt, the status times are extended to at least 10 ms by retriggerable monoflops. After power on iC-RC1000 starts in Signal error status, setting the Signal OK status at the earliest after the monoflop period has elapsed. The status outputs are configured as push-pull drivers so that optocouplers can be directly connected up to the device (10 mA low side, 4 mA high side).

The front end signal splitter isolates the two diagnostic channels from one another and provides protection against overvoltage with the help of external resistors (39 kΩ at each signal input). The integrated clamp circuit then reduces the input voltage to within the permissible range. At the same time this decouples the signal source so that a controller can simulate an error by loading an input pin. So that signal failures can be detected should there be a fractured cable, for example, integrated pull-down resistors (2.5 MΩ) drag the DC potential into the error range.

iC-RC1000 works with a supply voltage of 5 V. The diagnostic channels can be supplied by one or two separate power packs and mutually monitor the applied supply voltage. The device is protected against ESD and in the given circuit is overvoltage-proof at the front end up to 36 V.

iC-RC1000

SIN/COS SIGNAL SAFETY MONITOR IC

preliminary



Rev A2, Page 3/10

PACKAGES

PIN CONFIGURATION

MSOP10 according to JEDEC MO-187BA
(3 mm x 3 mm, lead pitch 0.5 mm)

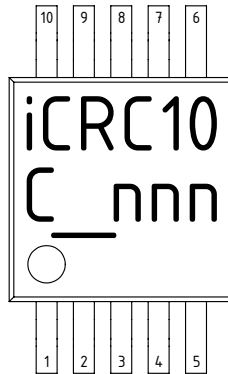

PIN FUNCTIONS

No. Name Function

1	NSIN	Inverted Sine Input
2	PSIN	Sine Input
3	GND	Ground
4	PCOS	Cosine Input
5	NCOS	Inverted Cosine Input
6	OK	OK Indication Output
7	VCC1	+5 V Supply Voltage Channel OK
8	GND	Ground
9	VCC2	+5 V Supply Voltage Channel ERR
10	ERR	ERROR Indication Output

Ground can be connected to
pin 3 or pin 8.

iC-RC1000

SIN/COS SIGNAL SAFETY MONITOR IC

preliminary



Rev A2, Page 4/10

PACKAGE DIMENSIONS MSOP10 3x3

SIDE

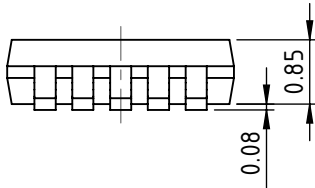

FRONT

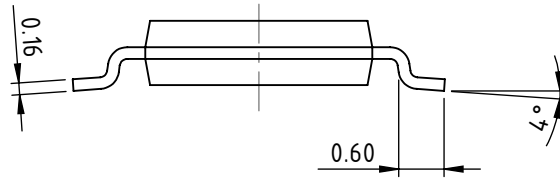

TOP

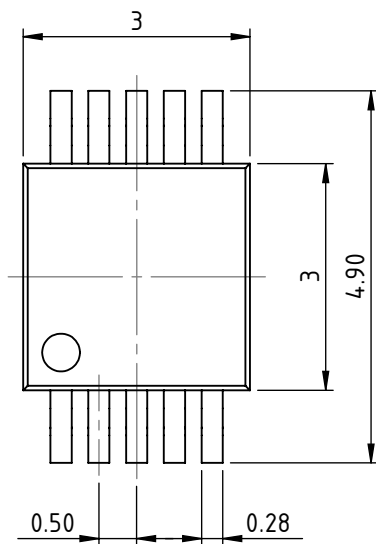

RECOMMENDED PCB-FOOTPRINT

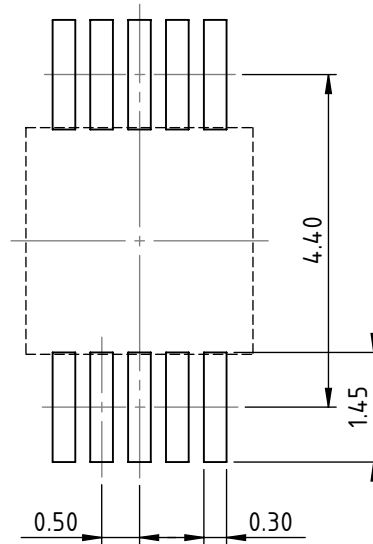

dra_msop10-1_pack_1, 10:1

iC-RC1000

SIN/COS SIGNAL SAFETY MONITOR IC



Rev A2, Page 5/10

ABSOLUTE MAXIMUM RATINGS

These ratings do not imply permissible operating conditions; functional operation is not guaranteed. Exceeding these ratings may damage the device.

Item No.	Symbol	Parameter	Conditions	Min.		Max.		Unit
G001	V(VCC)	Voltage at VCC1, VCC2		-0.3		7		V
G002	I(VCC)	Current in VCC1, VCC2		-10		25		mA
G003	Vin()	Voltage at PSIN, NSIN, PCOS, NCOS		-0.3		7		V
G004	Iin()	Current in PSIN, NSIN, PCOS, NCOS		-10		10		mA
G005	Vout()	Voltage at ERR, OK		-0.3		7		V
G006	Iout()	Current in ERR, OK		-10		25		mA
G007	Ilu()	Pulse Current in all pins (latch-up susceptibility)	according to Jedec Standard No. 78; Ta = 25 °C, pulse duration to 10 ms, VCC1 = VCC1 _{max} , VCC2 = VCC2 _{max} , Vlu() = (-0.5...+1.5) x Vpin() _{max}	-100		100		mA
G008	Vd()	ESD Susceptibility at all pins	HBM 100pF discharged through 1.5 kΩ			2		kV

THERMAL DATA

Operating conditions: VCC1 = 5 V ±10 %, VCC2 = 5 V ±10 %

Item No.	Symbol	Parameter	Conditions	Min.		Typ.		Max.		Unit
T01	Ta	Operating Ambient Temperature Range (extended range on request)		-40				110		°C
T02	Rthja	Thermal Resistance Chip to Ambient				30				K/W

All voltages are referenced to ground unless otherwise stated.

All currents flowing into the device pins are positive; all currents flowing out of the device pins are negative.

iC-RC1000

SIN/COS SIGNAL SAFETY MONITOR IC



Rev A2, Page 6/10

ELECTRICAL CHARACTERISTICS

Operating conditions: VCC1 = 5 V ±10 %, VCC2 = 5 V ±10 %, T_J = -40 ... 125 °C, unless otherwise stated

Item No.	Symbol	Parameter	Conditions				Unit
				Min.	Typ.	Max.	
Total Device							
001	V _{in()}	Permissible Input Voltage at PSIN, NSIN, PCOS, NCOS		36		77	%VCC
002	V _{c()hi}	Clamp Voltage hi at PSIN, NSIN, PCOS, NCOS	V _{c()hi} = V() – VCC1 or VCC2, I() = 10 mA	0.7		2	V
003	V _{c()lo}	Clamp Voltage lo at all Pins	I = -1 mA	-1.2		-0.3	V
004	f _{in()}	Permissible Input Frequency	signal monitoring operational	0		500	kHz
005	R _{pd()}	Pull-down Resistor at PSIN, NSIN, PCOS, NCOS			2.5		MΩ
Channel OK, Channel ERR							
301	VCC	Permissible Supply Voltage at VCC1, VCC2		4.5		5.5	V
302	I(VCC)	Supply Current in VCC1, VCC2	T _J = 27 °C, no Load		0.7		mA
303	VCC _{con}	Turn-on Threshold VCC1, VCC2 (power-on release)	increasing voltage VCC	4.2		4.4	V
304	VCC _{coff}	Turn-off Threshold VCC1, VCC2 (power-down reset)	decreasing voltage VCC	3.9		4.2	V
305	VCC _{chys}	Hysteresis at VCC1, VCC2	VCC _{chys} = VCC _{con} – VCC _{coff}	100		400	mV
306	V _{pp()} _{max}	Differential Voltage Threshold Maximum-Alarm	referred to Figure 1	1.2	1.3	1.4	V _{pp}
307	V _{pp()} _{min}	Differential Voltage Threshold Minimum-Alarm	referred to Figure 1	0.6	0.7	0.8	V _{pp}
308	V _{dc()} _{max}	DC-Check Maximum Voltage Threshold	referred to Figure 2	73	76	79	%VCC
309	V _{dc()} _{min}	DC-Check Minimum Voltage Threshold	referred to Figure 2	30	33	36	%VCC
310	V _{s()} _{hi}	Saturation Voltage hi at OK, ERR	V _{s(OK)hi} = VCC1 - V(); I() = -4 mA V _{s(OK)hi} = VCC1 - V(); I() = -1.6 mA V _{s(ERR)hi} = VCC2 - V(); I() = -4 mA V _{s(ERR)hi} = VCC2 - V(); I() = -1.6 mA		0.7	1	V V V V
311	V _{s()} _{lo}	Saturation Voltage lo at OK, ERR	I() = 10 mA I() = 4 mA		0.7	1	V V
312	I _{sc()} _{hi}	Short-Circuit Current hi at OK, ERR	V(OK) = 0 V ... VCC1 - 1 V V(ERR) = 0 V ... VCC2 - 1 V	-10		-4	mA
313	I _{sc()} _{lo}	Short-Circuit Current lo at OK, ERR	V(OK) = 1 V ... VCC1 V(ERR) = 1 V ... VCC2	11		25	mA
314	t _{d()}	Minimum Duration of Lo-Signal at OK Hi-Signal at ERR		10		20	ms
315	I _{r()}	Reverse Current in OK, ERR	VCC1 = 0 or open, V(OK) = 5.5 V VCC2 = 0 or open, V(ERR) = 5.5 V			500 100	μA μA
316	V _{r()}	Back Bias Voltage at VCC1, VCC2	VCC1 open, V(OK) = 5.5 V VCC2 open, V(ERR) = 5.5 V	0 0		0.5 2.2	V V

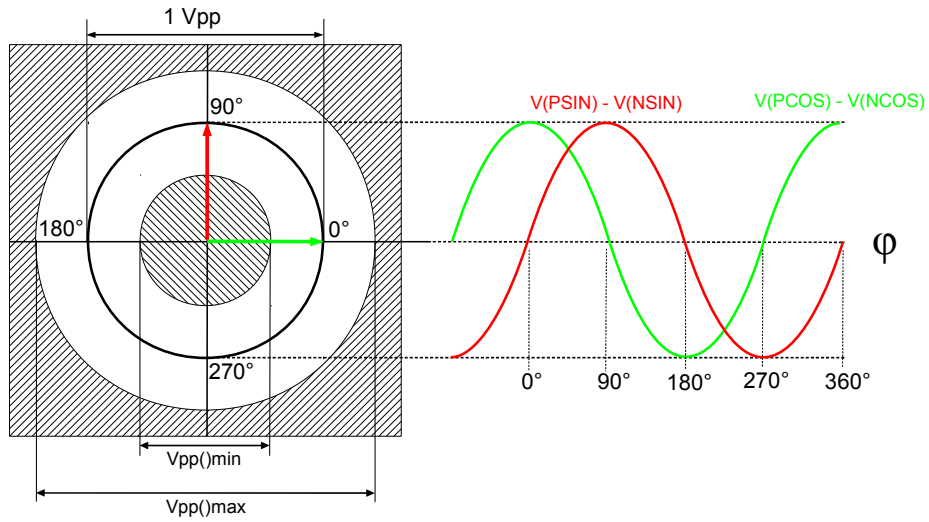

Figure 1: Differential voltage thresholds for maximum and minimum alarm.

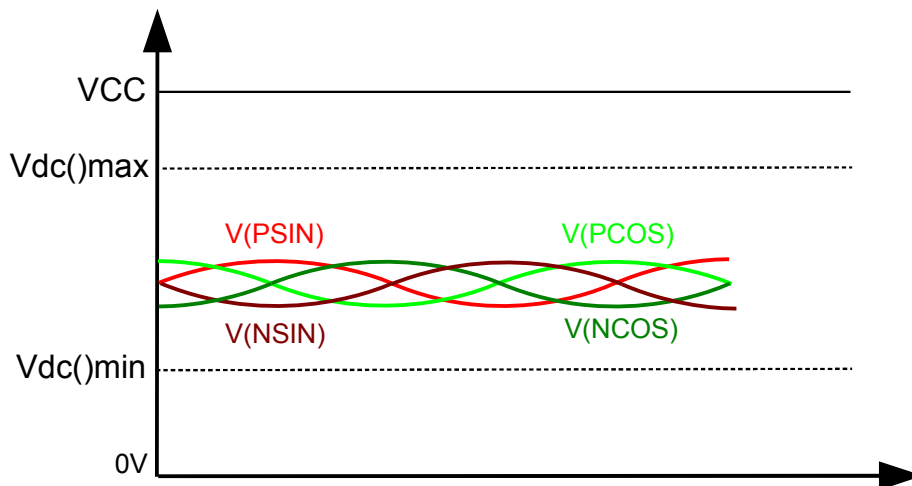

Figure 2: Maximum and minimum threshold voltages for DC check.

APPLICATION NOTES

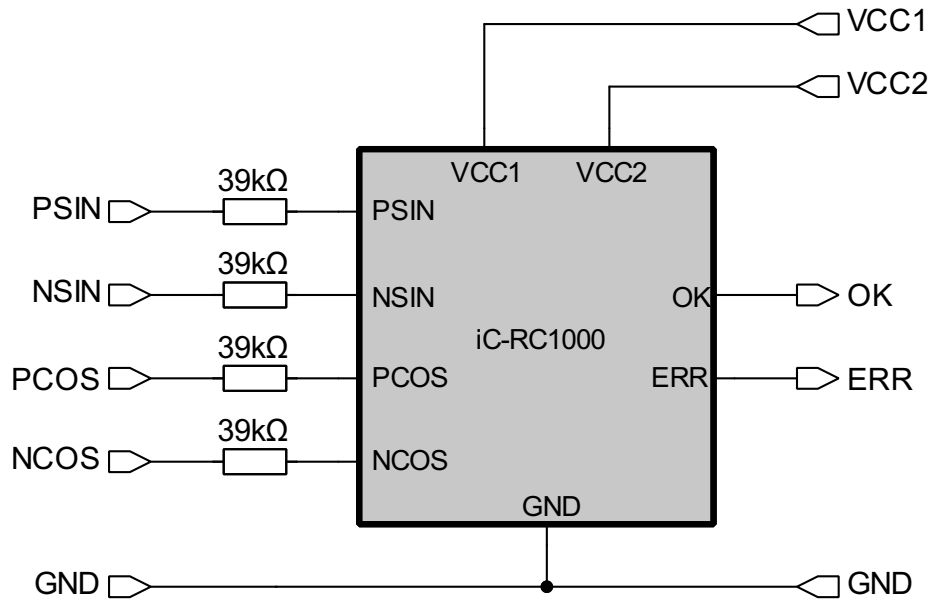

Figure 3: Overvoltage protection up to 36 V is obtained using external 39 kΩ resistors.

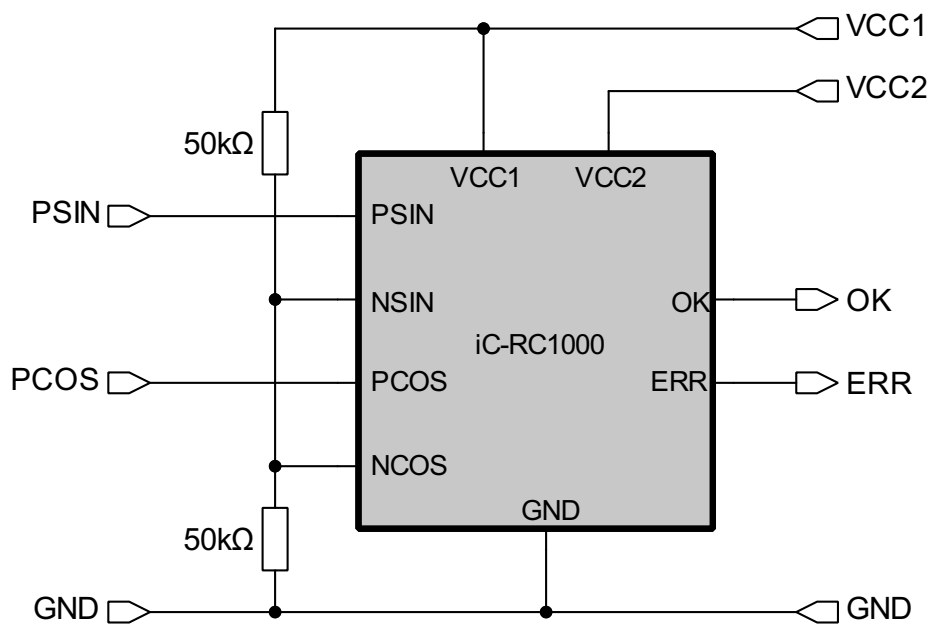

Figure 4: Single-ended application.

iC-RC1000

SIN/COS SIGNAL SAFETY MONITOR IC

preliminary



Rev A2, Page 9/10

iC-Haus expressly reserves the right to change its products and/or specifications. An info letter gives details as to any amendments and additions made to the relevant current specifications on our internet website www.ichaus.de/infoletter; this letter is generated automatically and shall be sent to registered users by email.

Copying – even as an excerpt – is only permitted with iC-Haus' approval in writing and precise reference to source.

iC-Haus does not warrant the accuracy, completeness or timeliness of the specification and does not assume liability for any errors or omissions in these materials.

The data specified is intended solely for the purpose of product description. No representations or warranties, either express or implied, of merchantability, fitness for a particular purpose or of any other nature are made hereunder with respect to information/specification or the products to which information refers and no guarantee with respect to compliance to the intended use is given. In particular, this also applies to the stated possible applications or areas of applications of the product.

iC-Haus conveys no patent, copyright, mask work right or other trade mark right to this product. iC-Haus assumes no liability for any patent and/or other trade mark rights of a third party resulting from processing or handling of the product and/or any other use of the product.

As a general rule our developments, IPs, principle circuitry and range of Integrated Circuits are suitable and specifically designed for appropriate use in technical applications, such as in devices, systems and any kind of technical equipment, in so far as they do not infringe existing patent rights. In principle the range of use is limitless in a technical sense and refers to the products listed in the inventory of goods compiled for the 2008 and following export trade statistics issued annually by the Bureau of Statistics in Wiesbaden, for example, or to any product in the product catalogue published for the 2007 and following exhibitions in Hanover (Hannover-Messe).

We understand suitable application of our published designs to be state-of-the-art technology which can no longer be classed as inventive under the stipulations of patent law. Our explicit application notes are to be treated only as mere examples of the many possible and extremely advantageous uses our products can be put to.

iC-RC1000

SIN/COS SIGNAL SAFETY MONITOR IC

preliminary



Rev A2, Page 10/10

ORDERING INFORMATION

Type	Package	Order Designation
iC-RC1000	MSOP10	iC-RC1000 MSOP10

For technical support, information about prices and terms of delivery please contact:

iC-Haus GmbH
Am Kuemmerling 18
D-55294 Bodenheim
GERMANY

Tel.: +49 (61 35) 92 92-0
Fax: +49 (61 35) 92 92-192
Web: <http://www.ichaus.com>
E-Mail: sales@ichaus.com

Appointed local distributors: http://www.ichaus.com/sales_partners