



MBR1040C

Preliminary

DIODE

10A SCHOTTKY BARRIER RECTIFIER

DESCRIPTION

The UTC **MBR1040C** is a Schottky Barrier Rectifier with high efficiency, low power dissipation and high current capacity. It can be applied in high frequency, low voltage inverters, polarity protection and free wheeling applications.

FEATURES

- * High surge capability
- * High efficiency, low power dissipation, high current capability, low forward voltage drop
- * Guardring for overvoltage protection

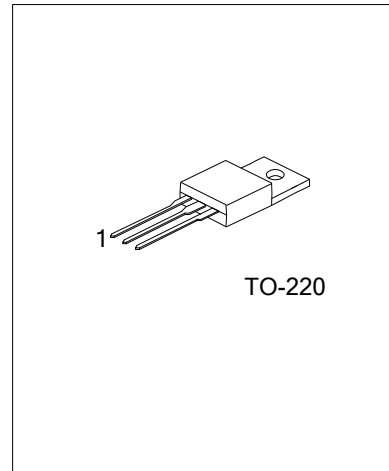

ORDERING INFORMATION

Ordering Number		Package	Pin Assignment			Packing
Lead Free	Halogen Free		1	2	3	
MBR1040CL-TA3-T	MBR1040CG-TA3-T	TO-220	A	K	A	Tube

Note: Pin Assignment: A: Anode K: Cathode

<p>MBR1040CL-TA3-T</p> <p>(1)Packing Type (2)Package Type (3)Lead Free</p>	<p>(1) T: Tube (2) TA3: TO-220 (3) Halogen Free, L: Lead Free</p>
--	---

■ ABSOLUTE MAXIMUM RATINGS (T_A=25°C unless otherwise specified)

PARAMETER	SYMBOL	RATINGS	UNIT	
RMS Reverse Voltage	V _{R(RMS)}	28	V	
Peak Repetitive Reverse Voltage	V _{R(RM)}	40	V	
Working Peak Reverse Voltage	V _{R(WM)}	40	V	
DC Blocking Voltage	V _R	40	V	
Peak Reverse Current at Rated DC Blocking Voltage	I _{RM}	0.1	mA	
		T _C = 125°C		15
Average Rectified Output Current (Note 2)	T _C = 105°C	I _O	10	A
Non-Repetitive Peak Forward Surge Current 8.3ms Single half sine-wave superimposed on rated load (JEDEC Method)	I _{FSM}	125	A	
Repetitive Peak Reverse Surge Current	t ≤ 2.0μs	I _{R(RM)}	1.0	A
Operating Temperature	T _J	-65 ~ +150	°C	
Storage Temperature	T _{STG}	-65 ~ +150	°C	

Note: 1. Absolute maximum ratings are those values beyond which the device could be permanently damaged. Absolute maximum ratings are stress ratings only and functional device operation is not implied.
 2. Thermal resistance junction to case mounted on heatsink.

■ ELECTRICAL CHARACTERISTICS (T_A=25°C unless otherwise specified)

PARAMETER	SYMBOL	TEST CONDITIONS	MIN	TYP	MAX	UNIT
Forward Voltage Drop	V _{FM}	I _F = 5.0A, T _C = 125°C			0.57	V
		I _F = 5.0A, T _C = 25°C			0.70	
		I _F = 10A, T _C = 25°C			0.84	
Typical Junction Capacitance (Note)	C _J				150	pF
Voltage Rate of Change (Rated V _R)	dV/dt				1000	V/μs

Note: Measured at 1.0MHz and applied reverse voltage of 4.0V DC.

UTC assumes no responsibility for equipment failures that result from using products at values that exceed, even momentarily, rated values (such as maximum ratings, operating condition ranges, or other parameters) listed in products specifications of any and all UTC products described or contained herein. UTC products are not designed for use in life support appliances, devices or systems where malfunction of these products can be reasonably expected to result in personal injury. Reproduction in whole or in part is prohibited without the prior written consent of the copyright owner. The information presented in this document does not form part of any quotation or contract, is believed to be accurate and reliable and may be changed without notice.