



## Thermatel® Model TD1/TD2 Thermal Dispersion Flow/Level/Interface Switch

### DESCRIPTION

TD1 and TD2 Thermal Dispersion flow/level/interface switches provide a new level of performance and reliability not found in previous switches. Continuous diagnostics with fault indication, temperature compensation, narrow hysteresis and fast response time make the TD1/TD2 the latest in thermal dispersion switch technology.

TD1 is a basic switch with 24 VDC power and an 8-amp DPDT relay. The TD2 adds LED indication through a glass window, ability to electrically measure the set point, mA output for diagnostics and trending, optional hermetically sealed relay, plus time delay. A universal AC power supply simplifies installation.

Thermatel® probes are available in 316 Stainless Steel, Hastelloy® C, or Monel® with all welded construction.

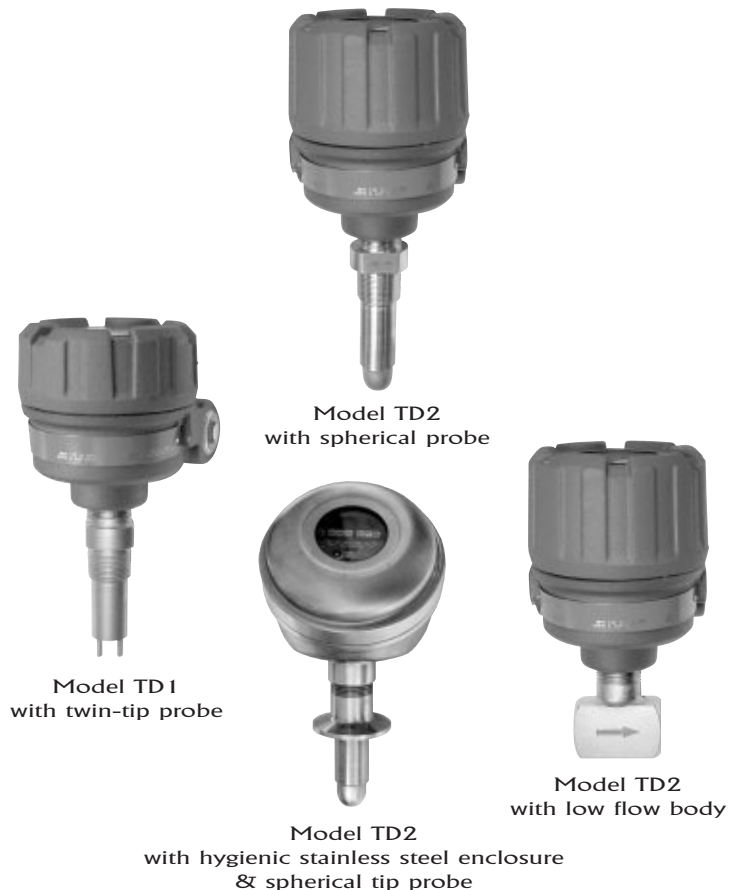

### FEATURES

- Temperature compensated to provide repeatable alarm under varying process temperatures
- Continuous diagnostics detect sensor fault
- Non-linear mA output signal can be used for trending, diagnostics and repeatable flow/level indication (TD2)
- Detects minimum flow or presence/absence of flow
- Easy/fast calibration
- Excellent low flow sensitivity
- Optional hot tap available (see bulletin 41-103)
- Hygienic design available
- NACE construction available (consult factory)
- Process temperatures from -100° to +400° F (-73° to +204° C)—High temp. version to +850° F (+454° C)

### TECHNOLOGY

The Thermatel® TD1 and TD2 switches utilize the Magnetrol® proven thermal dispersion technology. The sensor consists of two RTD elements. One is the reference and the second is heated to a temperature above the process temperature. The electronics detect the temperature difference between the two elements. The temperature difference is greatest in air, then decreases when cooling occurs due to a change in media. An increase in the flow rate further decreases the temperature difference.

The set point is adjusted for the switch to alarm at the desired temperature difference. Once the set point is reached, the relay will change state.

# ADVANCED FEATURES - TD1 & TD2

## TEMPERATURE COMPENSATION

The alarm point of thermal dispersion switches has previously been affected by changing temperatures. With the TD1/TD2, the effect of varying process temperature has been greatly reduced.

### No Temperature Compensation

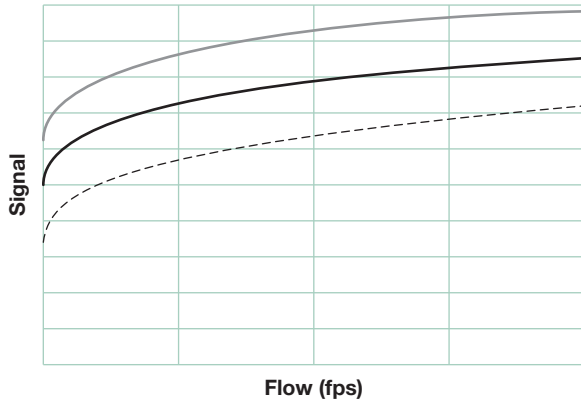

### With Temperature Compensation

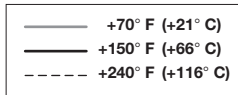
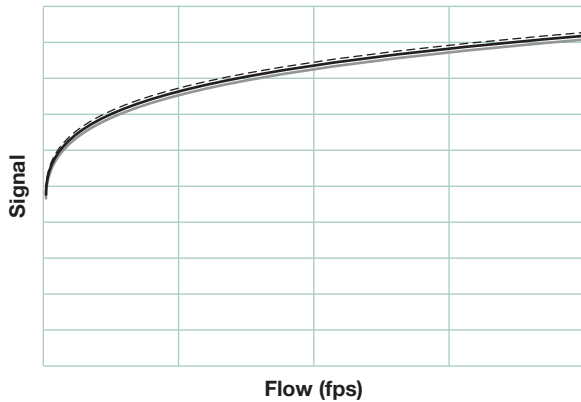

## FACTORY CALIBRATION

The THERMATEL flow switch can be ordered factory calibrated to alarm at a specified flow rate. A complete calibration curve can also be provided for the TD2. Using this curve the user can determine the desired set point. Using a volt meter, adjust the set point until the desired alarm point is obtained. Calibration can be performed on water and select organic compounds.

## HOT TAP

Hot tap retractable probe assemblies for THERMATEL probes are available. See Bulletin 41-103.

## FAULT DETECTION

One of the major concerns is questioning if the switch will operate when an alarm condition occurs. The TD1/TD2 is equipped with advanced diagnostics which continuously monitor the signal from the sensor and indicate if the signal has gone out of range. In the event of a fault, the alarm relay will de-energize and the red LED will blink. In the TD2 the mA output will change to 3.6 mA (Low Level Fail-safe) or 22 mA (High Level Fail-safe) to indicate a fault.

# ADVANCED FEATURES - TD2 ONLY

## mA output

The TD2 has a mA output signal can be used for diagnostics, fault detection and trending. While this mA signal is not scalable by the user, it can provide important process information. The mA signal will increase with the sensor cooling – mA will be greater in a wet condition than in a dry condition and will further increase as the flow rate increases.

The mA output can also be used for fault detection. In the event of a fault, the mA output will follow NAMUR NE 43 and go to less than 3.6 mA for Low Level Fail-safe and greater than 22 mA for High Level Fail-safe selection. Due to ATEX requirements the mA output is not available on units for Zone 0 service (Model number digit 9 = C).

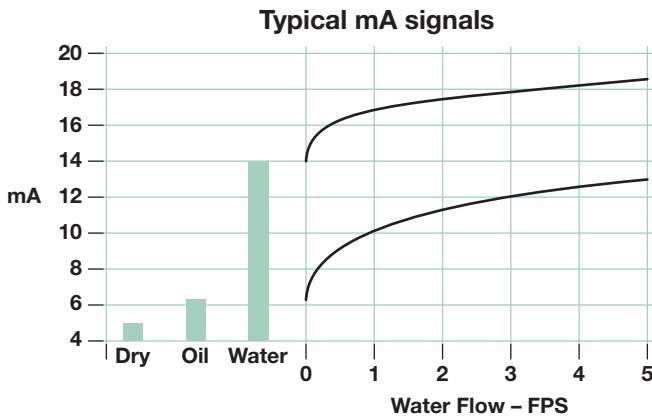

## Measure the set point

With the TD2 the user can obtain an electrical measurement of the set point. This permits the user to periodically check the calibration point and verify that the set point has not changed. Due to ATEX requirements, this feature is not available on units for Zone 0 service (Model number digit 9 = C).

## Remote Electronics

The TD2 can be provided with remote electronics with up to 500 feet (150 meters) separation between the probe and electronics.

## Hermetically sealed relay

The TD2 provides an optional hermetically sealed relay for the most demanding applications.



**Model TD2 with Window**

# APPLICATIONS

---

THERMATEL has demonstrated reliable performance as a flow or level switch. For use as a flow switch, THERMATEL can be used to detect either a high flow or a low flow condition for both gases and liquids. As a level switch, THERMATEL can be used to detect difference in thermal conductivity of various media. This includes interface detection between media such as liquid/foam, and oil/water.

## LEVEL SWITCH

Level or Interface can be detected due to differences in thermal conductivity. High or low level alarm applications may be installed either vertically or horizontally.

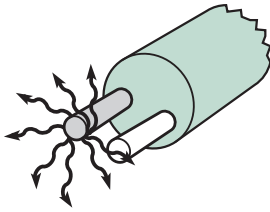

**Low Level**

In the absence of media, the self-heated sensor tip creates a temperature difference between the two sensors.

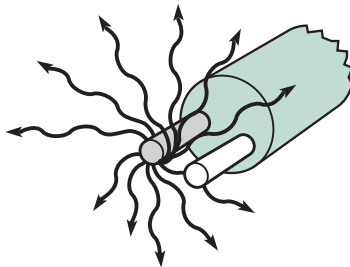

**High Level**

As media contacts the sensor tip, heat is absorbed by the fluid, decreasing the temperature difference.

## FLOW SWITCH

Flow is detected by an increase in heat transfer that occurs as the flow rate increases. Exceptional low flow sensitivity is obtained with no moving parts. The same unit can be used for both liquid and gas flow detection.

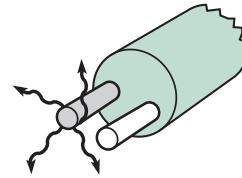

**No Flow**

In a low flow condition, the self-heated sensor tip creates a temperature differential between the two sensors.

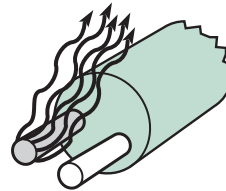

**Flow**

As flow increases, heat is dissipated and temperature difference decreases.

# PROBE DESIGNS

THERMATEL offers two sensor tip designs—the original twin tip and the unique spherical tip. Both designs have similar operating ranges.

The sensors in the twin tip are mounted at the end of each tip. In the spherical tip, the sensors are bonded directly to the wall of the tip, providing protection of the sensors.

The spherical tip is recommended for all types of applications—general purpose, high viscosity, and applications where buildup can occur.



**Typical Air Flow**

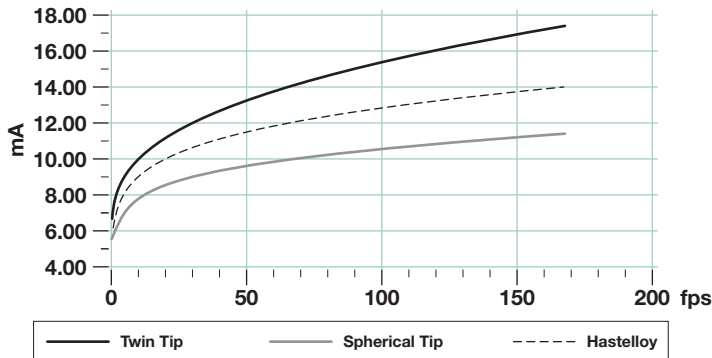

**Typical Water Flow**

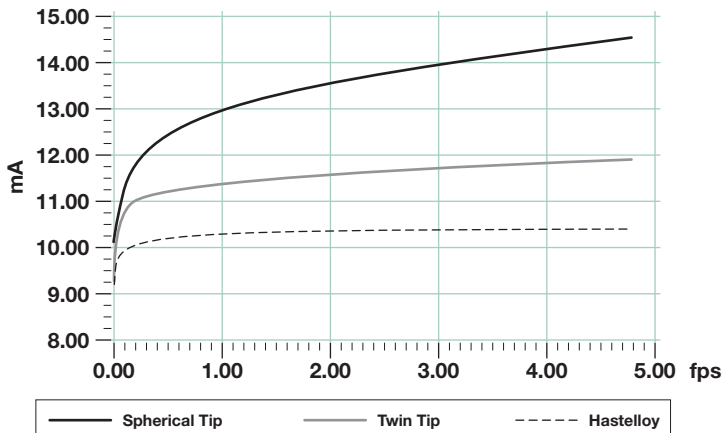

## Spherical Tip

For general purpose use, liquid flow applications, buildup, and hygienic service. Suitable for gas flow applications. Maximum temperature of +400° F (+200° C).

## Twin Tip

For higher pressures up to 3000 psig, corrosion resistant materials including Monel and Hastelloy C. Twin tip probes are preferred for air flow applications. Maximum temperature of +400° F (+200° C).

## High Temperature/High Pressure (HTHP)

Suitable for temperatures up to +850° F (+454° C) Pressures up to 6000 psi (410 bar). Available in both 316/316L stainless steel and Hastelloy C construction.

## Mini Sensor

This twin tip sensor is suitable for installing in a Tee in smaller pipe sizes. Available with ½", ¾" and 1" NPT connections for use with appropriate tee connection. The twin tip design provides minimal blockage of the pipe.

## Low Flow Body

Used for even lower flow rates with ¼" and ½" connections. Liquid flow as low as 0.0055 gph (0.02 l/h) and gas flow rates of 100 sccm can be detected.

## Recommended set point ranges for various size tees

Size	Water	Air
¼" Flow body	0.0055 GPH – 1.5 GPH (0.02 – 5.7 l/h)	100 sccm to 200 SCFH (100 sccm to 5.75 Nm³/h)
½" Flow body	0.01 to 3 GPH (0.04 to 11.5 l/h)	250 sccm to 400 SCFH (250 sccm to 11.5 Nm³/h)
½" Tee	0.2 to 180 GPH (0.75 to 680 l/h)	0.5 to 70 SCFM (0.85 to 120 Nm³/h)
¾" Tee	0.5 to 240 GPH (2 to 900 l/h)	1.5 to 100 SCFM (2.5 to 170 Nm³/h)
1" Tee	1 to 420 GPH (3.8 to 1600 l/h)	3 to 170 SCFM (5 to 290 Nm³/h)

# APPLICATIONS

## PUMP PROTECTION

Installed on the discharge of a pump, a THERMATEL switch provides rapid indication of a low flow or no flow condition to prevent pump damage. No moving parts, excellent low flow sensitivity, and low hysteresis between alarm and reset points are all important features in this application. Enhanced temperature compensation minimizes set point drift due to varying process temperatures.

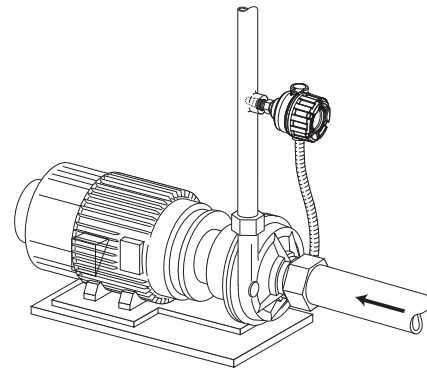

**Pump Protection**

## COOLING WATER/COOLING AIR

Maintaining the flow of cooling air or water is essential to protect heat generating equipment. A reliable flow switch will ensure that sufficient cooling media is flowing in the pipe. A low flow alarm will provide indication of inadequate cooling prior to overheating of the device being protected.

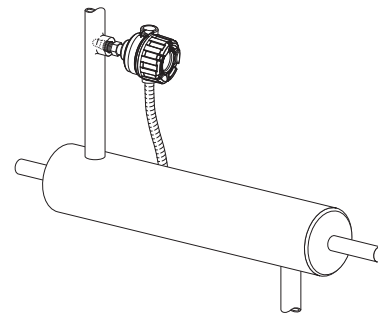

**Cooling Water/Cooling Air**

## LEVEL

A THERMATEL switch can be calibrated to detect the difference between two media based upon the difference in thermal conductivity. This can include wet/dry, oil/water interface, air/foam and foam/liquid. The sensitivity of the switch can easily be adjusted for a wide range of conditions. Probes can be mounted from the top or side of the tank.

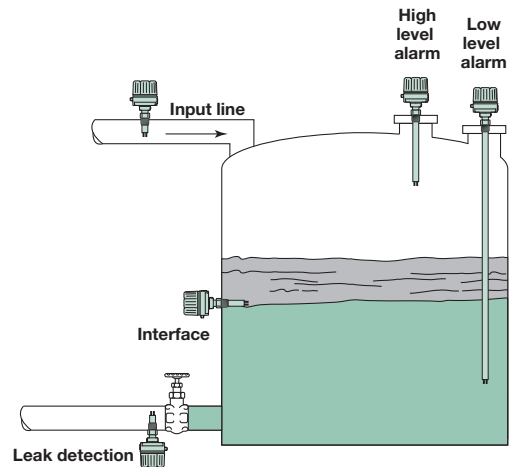

**Level**

## CHEMICAL FEED PUMPS

Monitoring the addition of chemicals into a process is vital for good performance. The TD1/TD2 with the low flow body can handle extremely low flow rates of both liquids and gases. With the TD2, time delay can be added.

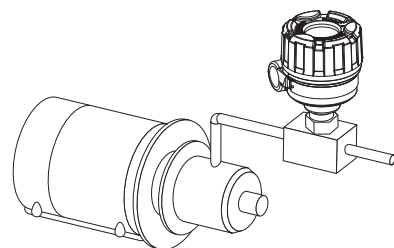

**Chemical Feed Pump**

# APPLICATIONS

## RELIEF VALVE MONITORING

When installed downstream of a relief valve, the switch can detect when flow occurs. The low flow sensitivity of the sensor permits the switches to be calibrated to detect minor valve leakage.

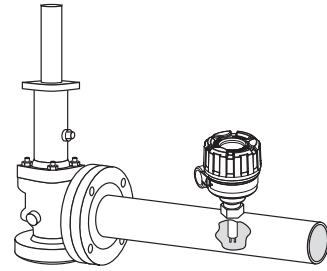

**Relief Valve Monitoring**

## LUBRICATION SYSTEMS

The flow switch with the low flow body can be used to ensure that sufficient quantities of lubrication oil are flowing throughout the entire lubrication system. No moving parts and large openings prevent buildup or plugging which can occur with mechanical switches.

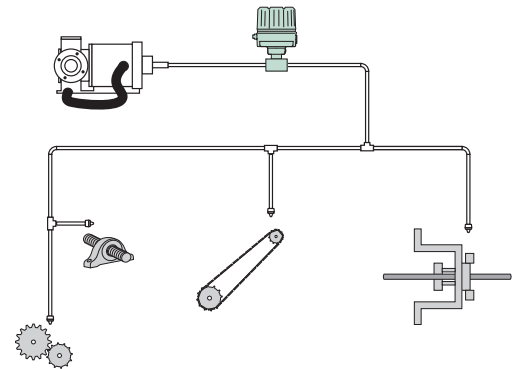

**Lubrication Systems**

## OTHER APPLICATIONS

- Exhaust Flow Monitoring
- Seal Leakage
- Safety Showers/Eyewash Stations
- Leak Detection
- Vacuum Pumps Seal Fluid
- Paint Flow
- Sampling Systems
- Analyzer Flow

# SPECIFICATIONS

Supply Voltage	TD1 19.2 to 28.8 VDC TD2 19.2 to 28.8 VDC or 100 to 264 VAC , 50-60 Hz
Power Consumption	TD1: 3.5 Watts at 24 VDC 4.5 Watts at 30 VDC TD2: 4 Watts at 24 VDC 4.5 Watts at 30 VDC 5 Watts at 100 to 264 VAC
Power to Probe	Less than 1 Watt
Output Relay	TD1 Electronics: DPDT, 8 amp at 120 VAC, 250 VAC 8 amp at 30 VDC, 0.5 amp at 125 VDC TD2 Electronics: DPDT, 8 amp at 120 VAC, 250 VAC 8 amp at 30 VDC, 0.5 amp at 125 VDC or Hermetically Sealed DPDT 1 amp at 28 VDC, 0.5 amp at 125 VDC
Ambient Temperature	Electronics: -40° to +158° F (-40° to +70° C)
Storage Temperature	Electronics: -58° to +170° F (-50° to +76° C)

## SPECIFICATIONS (cont.)

Operating Temperature	Sensor:	-100° to +400° F (-73° to +200° C) ①
High Temperature Sensor		-100° to +850° F (-73° to +454° C)
Response Time		1–10 seconds (typical – dependent upon sensor type, application, and set point adjustment)
Set Point Range	Water:	0.01 to 5.0 fps (0.003 to 1.5 m/s) (spherical tip and twin tip sensors) 0.01 to 1.0 fps (0.003 to 0.3 m/s) (HTHP, Hastelloy, Monel sensors)
	Air:	0.1 to 500 fps (0.03 to 150 m/s)
Time Delay (TD2 only)		0–100 seconds adjustable (time delay in addition to sensor response)
Repeatability		<1% at constant temperature
Enclosure Material		Cast aluminum A356 containing less than 0.2% copper 316 stainless steel or 304 stainless steel
SIL		Safe Failure Fraction (SFF) TD1=69.3% TD2=73%

### Probes:

Probe Materials of Construction	Twin Tip	All wetted parts of 316/316L stainless steel, Hastelloy C, or Monel
	HTHP Sensor	316/316L stainless steel, Hastelloy C
	Mini Sensor	316/316L stainless steel
	Spherical Tip	316/316L stainless steel
	Low Flow Body	316/316L stainless steel
Process Connection		Refer to part number construction
Probe Insertion Length:		2" (5 cm) minimum.
Spherical Tip Probe, TXA, TXB		Available in lengths from 2 to 130" in 1" increments
Twin Tip Probe, TXC, TXD		(5 to 330 cm in 1 cm increments)
Mini Sensor, TEM, TMM		1" (2.5 cm) min; Available insertion lengths 1" to 130" (3 to 330 cm)
High Temperature Sensor TEH, TMH		2" (5 cm) min.; Available in lengths from 2 to 36" in 1" increments ②
		(5 to 91 cm in 1 cm increments)
Low Flow Body, TEL		¼" and ½" NPT and G (BSP) threads.
Cable Length		500 feet (150 meters) maximum
Shipping Weight		4.6 lbs. (with 2" probe)

## PRESSURE / TEMPERATURE RATING

(DEPENDENT ON PROCESS CONNECTION)





Probe Style	Insertion Length	Pressure/Temperature Rating		
		+100° F (+38° C)	+400° F (+204° C)	+850° F (+454° C)
Twin Tip (TXC, TXD) (stainless steel)	2" (5 cm)	3000 psig (206 bar)	2280 psig (157 bar)	—
	3–130" (7–330 cm)	1850 psig (127 bar)	1680 psig (115 bar)	—
Twin Tip (TXC, TXD) (Hastelloy C)	2" (5 cm)	3000 psig (206 bar)	2340 psig (161 bar)	—
	3–130" (7–330 cm)	1500 psig (103 bar)	1170 psig (80 bar)	—
Twin Tip (TXC, TXD) (Monel)	2" (5 cm)	2500 psig (172 bar)	1980 psig (136 bar)	—
	3–130" (7–330 cm)	1200 psig (82 bar)	950 psig (65 bar)	—
Spherical Tip (TXA, TXB)	2–130" (5–330 cm)	600 psig (41 bar)	415 psig (28 bar)	—
Mini Sensor (TXM)	1" (2.5 cm)	3000 psig (206 bar)	2280 psig (157 bar)	—
	2–130" (5–330 cm)	1850 psig (127 bar)	1680 psig (115 bar)	—
Low Flow Body (TEL)	—	5800 psig (400 bar)	4100 psig (285 bar)	—
High Temperature/ High Pressure (TXH)	2–36" (5–90 cm)	6000 psig (413 bar)	4280 psig (295 bar)	3380 psig (233 bar)

① Use a probe with heat extension or remote electronics for process temperatures greater than +250° F (+120° C)

② Longer lengths available. Consult factory.



# AGENCY APPROVALS

AGENCY	MODEL APPROVED	APPROVAL CATEGORY	APPROVAL CLASSES
<b>FM</b>  APPROVED	<b>TD1-2D00-0XX</b> <b>TD2-XX0X-Xab</b> <b>a = 3, C, G</b> <b>b = 0, 1, 2, 3</b>	Explosion Proof	Class I, Div 1; Groups B, C, D TD1=T6 TD2=T5 Class II & III, Div 1; Groups E, F, G Type 4X and IP66
	<b>TD1-2D00-0XX</b> <b>TD2-XX0X-XXX</b>	Non-Incendive	Class I, Div 2; Groups A, B, C, D Class II & III, Div 2; Groups E, F, G T4 Type 4X and IP66
	<b>PROBE MODEL</b> <b>TXX-XXXX-XXX</b>	Explosion Proof	Class I, Div 1; Groups B, C, D T4 Class II & III, Div 1; Groups E, F, G Type 4X and IP 66
<b>CSA</b> 	<b>TD1-2D00-0XX</b> <b>TD2-XX0X-Xab</b> <b>a = 3, C, G</b> <b>b = 0, 1, 2, 3</b>	Explosion Proof	Class I, Div 1; Groups B, C, D T6 Class II & III, Div 1; Groups E, F, G Type 4X and IP66
	<b>TD1-2D00-0XX</b> <b>TD2-XX0X-XXX</b>	Suitable for	Class I, Div 2; Groups A, B, C, D Class II & III, Div 2; Groups E, F, G T4 Type 4X and IP66
	<b>TD1-2D00-0X0</b> <b>TD2-XX0X-Xab</b> <b>a = 3, C, G</b> <b>b = 0, 1, 2, 3</b>	Explosion Proof	Class I, Zone 1, Ex d IIC T6
The probes and low flow body comply with Canadian Electric Code requirements of ANSI/ISA 12.27.01-2003 as a single seal device.	<b>PROBE MODEL</b> <b>TXX-XXX0-XXX</b>	Explosion Proof	Class I, Div 1; Groups B, C, D T4 Class II & III, Div 1; Groups E, F, G Type 4X and IP66
	<b>ATEX</b> 	<b>Zone 0 Service</b> <b>TXX-XDXX-XXC</b>	EEx d Explosion Proof w/IS probe
	<b>TXX-XHXX-XXC</b>	EEx d Explosion Proof (requires 1 mm probe provided when fourth digit of probe model number is B, C, or D)	⊕ II 1/2G EEx d IIC T5/T4 IP66
	<b>Zone 1 Service</b> <b>TXX-XXXX-XXG</b>	EEx d Explosion Proof	⊕ II 2G EEx d IIC T5/T4 IP66
<b>INMETRO</b> 	<b>TD1-2D00-0XX</b> <b>TD2-XD0X-XXC</b>	Ex d Explosion Proof w/IS probe circuit	BR-Ex d[ib] IIC T5/T4 IP66 - Electronics BR-Ex d+ib IIC T5/T4 IP66 - Probe
	<b>TXX-XHXX-XXC</b>	EEx d Explosion Proof (requires 1 mm probe provided when fourth digit of probe model number is B, C, or D)	BR-Ex d IIC T5/T4 IP66
	<b>Zone 1 Service</b> <b>TXX-XXXX-XXG</b>	EEx d Explosion Proof	BR-Ex d IIC T5/T4 IP66
<b>RosTECH/FSTS</b>	<b>TDX-XXXX-XXC</b> <b>TDX-XXXX-XXG</b>	Russian Authorisation Standards Consult MAGNETROL for details.	
<b>CCOE</b>	<b>TDX-XXXX-XXC</b> <b>TDX-XXXX-XXG</b>	Hazardous Approvals - India Consult MAGNETROL for details.	

 These units have been tested to EN 61326 and are in compliance with the EMC Directive 89/336/EEC.

# MODEL NUMBER

T D 1

Models available for quick shipment, usually within one week after factory receipt of a complete purchase order, through the Expedite Ship Plan (ESP)

### AGENCY APPROVAL

3	General Purpose, FM/CSA Explosion Proof approved
C	ATEX Ex d – Flameproof

### ENCLOSURE TYPE/CONDUIT CONNECTION

0	Aluminum A356 - ¾" NPT (dual entry)
1	Aluminum A356 - M20 (dual entry)



# MODEL NUMBER

T D 2

### POWER

7	AC Power
8	DC Power

### RELAY OUTPUT

D	DPDT Relay
H	DPDT hermetically sealed relay

### GLASS WINDOW IN ENCLOSURE

0	None
1	Window provided (not available on enclosure types 2 & 3)

### LOCATION

0	Integral
1	Remote (not available on enclosure code 4 & 5)

### AGENCY

3	General Purpose FM/CSA Class I, Division 1 & 2
7	General Purpose FM/CSA Class I, Division 2 *
C	ATEX Ex d – Zone 0 FM/CSA Class I, Division 1 & 2
G	ATEX Ex d – Zone 1 FM/CSA Class I, Division 1 & 2

\*Use with enclosure codes 4 & 5

### ENCLOSURE TYPE/CONDUIT CONNECTION

0	Aluminum A356 – ¾" NPT (dual entry)
1	Aluminum A356 – M20 (dual entry)
2	Cast 316 stainless steel – ¾" NPT (dual entry)
3	Cast 316 stainless steel – M20 (dual entry)
4	304 stainless steel – ½" NPT* (single entry)
5	304 stainless steel – M20* (dual entry)

\*Only available with Agency code 7

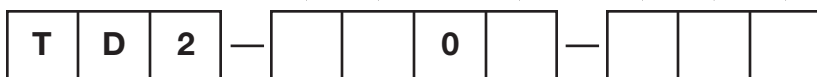

# MODEL NUMBER

## STANDARD PROBE

### MODEL

TE	Probe length in inches
TM	Probe length in centimeters

### TIP STYLE

A	Spherical tip ①	max. +250° F (+121° C)/max. 600 psi(41 bar)
B	Spherical tip – with 6-inch (15 cm) heat extension ①	max. +400° F (+204° C)/max. 600 psi (41 bar)
C	Twin tip	max. +250° F (+121° C)/max. 3000 psi (207 bar) ②
D	Twin tip – with 6-inch (15 cm) heat extension	max. +400° F (+204° C)/max. 3000 psi (207 bar) ②

① Available only with stainless steel construction

② Consult pressure/temperature chart on page 9 for pressure rating on extended length probe and various materials of construction.

### MATERIAL OF CONSTRUCTION

A	316/316L stainless steel
B	Hastelloy C
C	Monel
D	316/316L stainless steel twin tip with 1 mm probe thickness ③

③ Available only with TMC or TMD probes

### PROCESS CONNECTION SIZE/TYPE

11	¾" NPT Thread
21	1" NPT Thread
22	G1 (1" BSP) Thread

### ANSI RAISED FACE FLANGE CONNECTIONS

23	1"	150#	ANSI RF Flange	35	1½"	600#	ANSI RF Flange
24	1"	300#	ANSI RF Flange	43	2"	150#	ANSI RF Flange
25	1"	600#	ANSI RF Flange	44	2"	300#	ANSI RF Flange
33	1½"	150#	ANSI RF Flange	45	2"	600#	ANSI RF Flange
34	1½"	300#	ANSI RF Flange				

### EN/DIN FLANGED CONNECTIONS ④

BA	DN 25	PN 16	EN 1092-1 Type A	CC	DN 40	PN 64/100	EN 1092-1 Type B2
BB	DN 25	PN 25/40	EN 1092-1 Type A	DA	DN 50	PN 16	EN 1092-1 Type A
BC	DN 25	PN 64/100	EN 1092-1 Type B2	DB	DN 50	PN 25/40	EN 1092-1 Type A
CA	DN 40	PN 16	EN 1092-1 Type A	DD	DN 50	PN 64	EN 1092-1 Type B2
CB	DN 40	PN 25/40	EN 1092-1 Type A	DE	DN 50	PN 100	EN 1092-1 Type B2

④ DIN flanges only available in metric length (TMX) probes.

### HYGIENIC CONNECTIONS

3T	1" and 1½"	Tri-Clamp® ⑤
4T	2"	Tri-Clamp ⑤
VV	DN65	Varivent® ⑥

⑤ Only available for Spherical Sensor (TXA/TXB)  
Contact MAGNETROL for other hygienic fittings including  
Neumo, G1A, and DIN 11.851.

⑥ Only available for TXA TipStyle.

### INSERTION LENGTH

002	2" to 130" in 1" increments ⑦ Example: 4 inches = code <b>004</b> Note: minimum 3" with Flanges and G1 (BSP) threads
005	Minimum length 50 mm with NPT Threads
008	Minimum length 80 mm with G1 (BSP) and flange connections Extended lengths in 10 mm increments to length 3300 mm ⑦ Examples: 50 mm = code <b>005</b> , 3300 mm = code <b>330</b>

⑦ Longer lengths available — consult factory



# MODEL NUMBER

## HIGH TEMPERATURE / HIGH PRESSURE PROBE

### MODEL

TE	Probe length in inches
TM	Probe length in centimeters

### TIP STYLE

H	High temperature/high pressure twin tip	max. +850° F (+450° C)/max. 6000 psi (413 bar)
---	---	--

### MATERIAL OF CONSTRUCTION

A	316/316L stainless steel
B	Hastelloy C
D	316/316L stainless steel twin tip with 1 mm probe thickness ①

① Available only with TMH probes

### PROCESS CONNECTION SIZE/TYPE

11	¾" NPT Thread
21	1" NPT Thread
22	G1 (1" BSP) Thread

### ANSI RAISED FACE FLANGE CONNECTIONS

23	1"	150#	ANSI RF Flange	37	1½"	900/1500#	ANSI RF Flange
24	1"	300#	ANSI RF Flange	38	1½"	2500#	ANSI RF Flange
25	1"	600#	ANSI RF Flange	43	2"	150#	ANSI RF Flange
27	1"	900/1500#	ANSI RF Flange	44	2"	300#	ANSI RF Flange
33	1½"	150#	ANSI RF Flange	45	2"	600#	ANSI RF Flange
34	1½"	300#	ANSI RF Flange	47	2"	900/1500#	ANSI RF Flange
35	1½"	600#	ANSI RF Flange	48	2"	2500#	ANSI RF Flange

### EN/DIN FLANGED CONNECTIONS ②

BA	DN 25	PN 16	EN 1092-1 Type A	DA	DN 50	PN 16	EN 1092-1 Type A
BB	DN 25	PN 25/40	EN 1092-1 Type A	DB	DN 50	PN 25/40	EN 1092-1 Type A
BC	DN 25	PN 64/100	EN 1092-1 Type B2	DD	DN 50	PN 64	EN 1092-1 Type B2
BG	DN 25	PN 250	DIN 2527, Form E	DE	DN 50	PN 100	EN 1092-1 Type B2
CA	DN 40	PN 16	EN 1092-1 Type A	DG	DN 50	PN 250	DIN 2527, Form E
CB	DN 40	PN 25/40	EN 1092-1 Type A	DJ	DN 50	PN 400	DIN 2527, Form E
CC	DN 40	PN 64/100	EN 1092-1 Type B2				
CG	DN 40	PN 250	DIN 2527, Form E				
CJ	DN 40	PN 400	DIN 2527, Form E				

② DIN flanges only available on metric length (TMX) probes.

### INSERTION LENGTH

2" to 36" in 1" increments ③	
Example: 6-inch probe = <b>006</b>	
Note: minimum 3" with Flanges and G1 (BSP) threads	
005	Minimum length 50 mm with NPT Threads
007	Minimum length 70 mm with G1 (BSP) or flange connections
Extended lengths in 10 mm increments to 910 mm ③	
Examples: 50 mm = code <b>005</b> , 910 mm = code <b>091</b>	



③ Longer lengths available — consult factory

# MODEL NUMBER

## LOW FLOW BODY

### MODEL

TEL	Low Flow Body
-----	---------------

### MATERIAL OF CONSTRUCTION

A	316/316L stainless steel
---	--------------------------

### PROCESS CONNECTION SIZE/TYPE

T1	¼" NPT Thread
V1	½" NPT Thread
T0	G ¼ (¼" BSP) Thread
V0	G ½ (½" BSP) Thread

### MOUNTING BRACKET

000	None
100	With mounting bracket

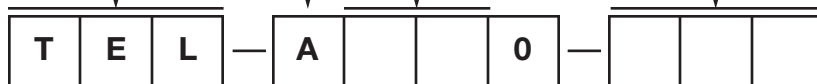

## MINI SENSOR

### MODEL

TE	Probe length in inches
TM	Probe length in centimeters

### BODY STYLE

M	Mini twin tip	max. +400° F (+204° C)/max. 3000 psi (207 bar) for standard sensor length max. +400° F (+204° C)/max. 1850 psi (127 bar) for sensors ≥ 2 inches (50 mm)
---	---------------	--

### MATERIAL OF CONSTRUCTION

A	316/316L stainless steel
---	--------------------------

### PROCESS CONNECTION SIZE/TYPE

01	½" NPT Thread
11	¾" NPT Thread
21	1" NPT Thread

### INSERTION LENGTH

001	1" to 130" in 1" increments
Example: 6 inch probe = code <b>006</b>	

50 mm to 3300 mm in 10 mm increments	
Examples: 50 mm = code 005, 3300 mm = code <b>330</b>	
Note: Use code <b>003</b> for minimum length of 25 mm	

Use 1-inch long probe when used with tee.

Example: Model Number of probe to fit in a ¾" tee is TEM-A110-001 or TMM-A110-003.

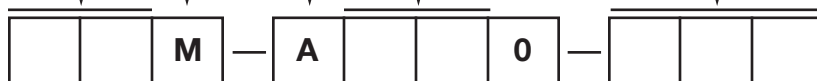

# MODEL NUMBER

## CONNECTING CABLE (GENERAL PURPOSE, FM/CSA)

### CONNECTING CABLE IN FEET

Cable length in feet; 10 feet minimum, 500 feet maximum length  
 Example: 12 feet = Code **012**



### CONNECTING CABLE IN METERS

3 meters minimum, 152 meters maximum length  
 Example: 3 meters = Code **003**

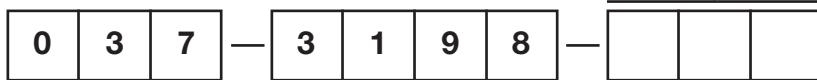

# DIMENSIONAL SPECIFICATIONS

## INCHES (MM)

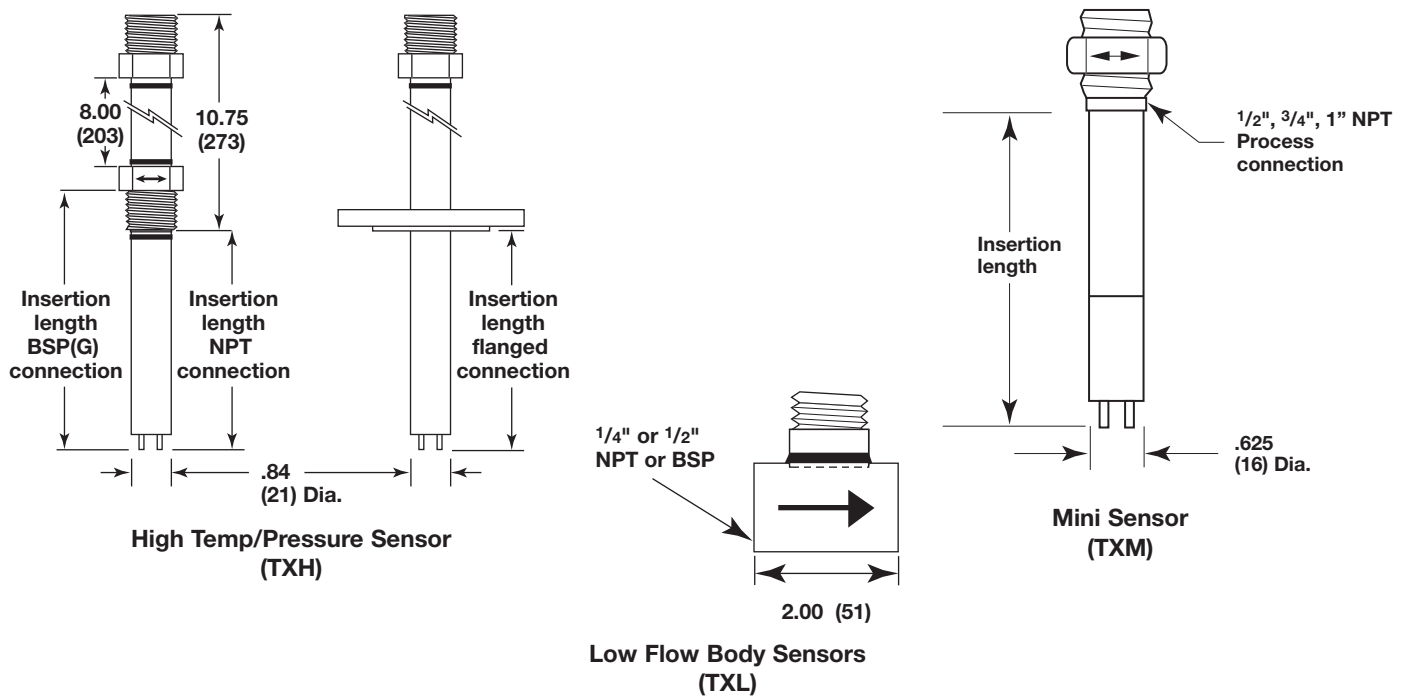

# DIMENSIONAL SPECIFICATIONS (cont.)

## INCHES (MM)

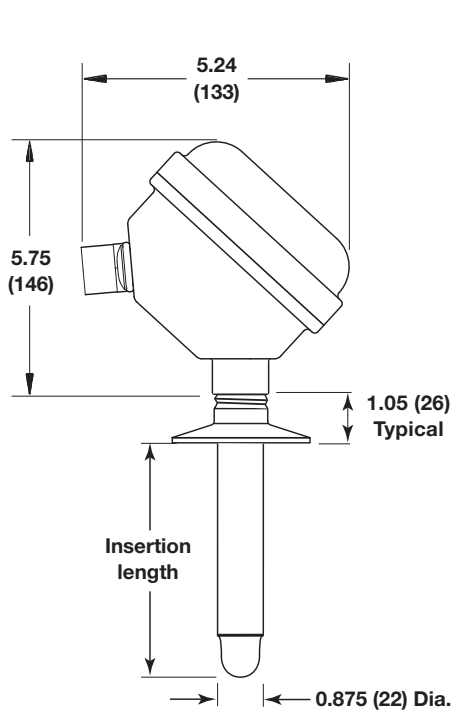

**Model TD2**  
with Hygienic Housing  
Tri-Clamp® Connection

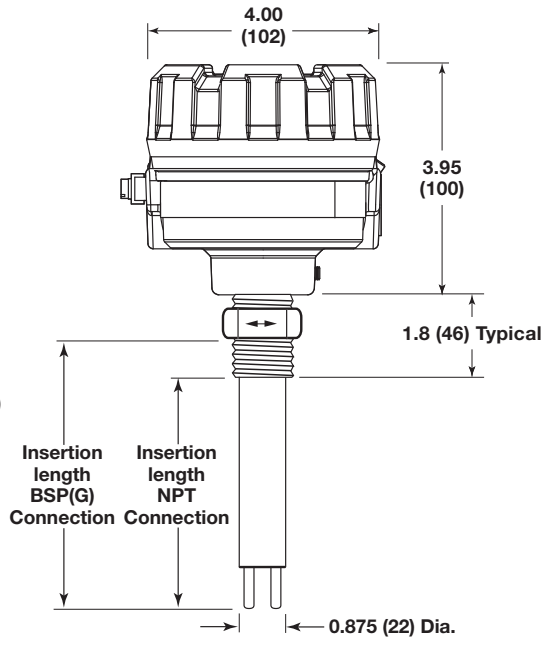

**Model TD1**  
with Twin Tip Sensor

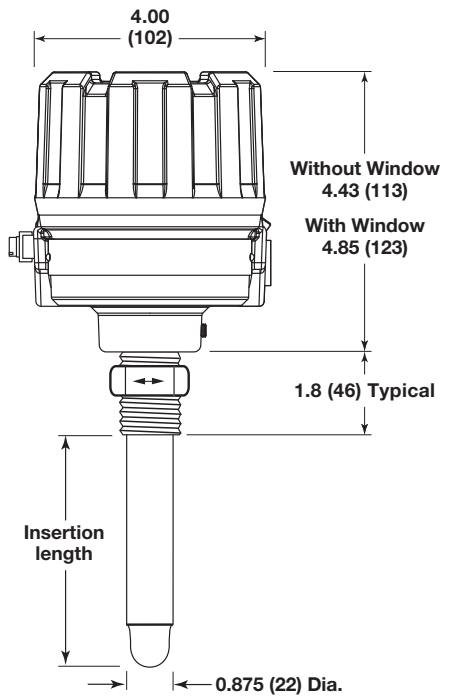

**Model TD2**  
Integral Electronics  
with Spherical Tip Sensor

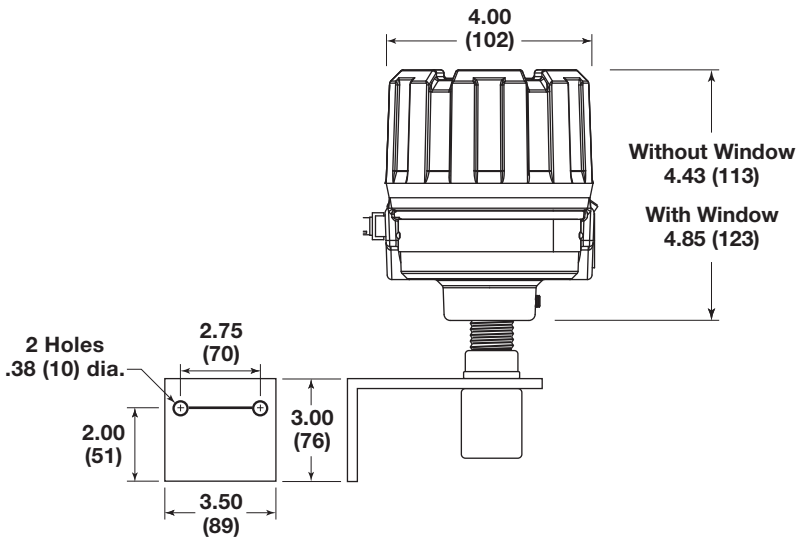

**Model TD2 with Remote Electronics**

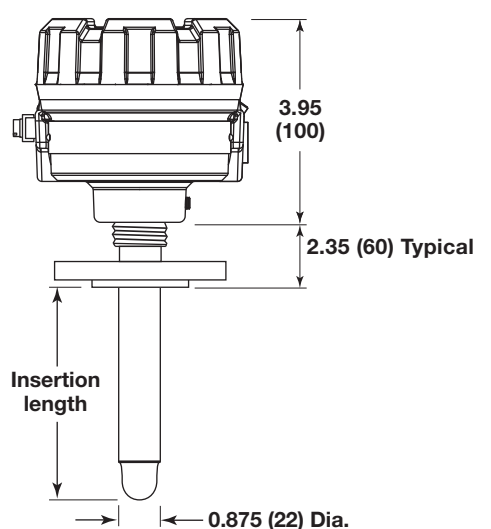

**Remote Spherical Tip Probe**  
with Flange Connection

# QUALITY

---



The quality assurance system in place at MAGNETROL guarantees the highest level of quality throughout the company. MAGNETROL is committed to providing full customer satisfaction both in quality products and quality service.

The MAGNETROL quality assurance system is registered to ISO 9001 affirming its commitment to known international quality standards providing the strongest assurance of product/service quality available.

# ESP

---

## **E**xpedite **S**hip **P**lan

Several THERMATEL flow and level switches are available for quick shipment, usually within one week after factory receipt of a purchase order, through the Expedite Ship Plan (ESP).

Models covered by ESP service are color coded in the selection data charts.

To take advantage of ESP, simply match the color coded model number codes (standard dimensions apply).

ESP service may not apply to orders of ten units or more. Contact your local representative for lead times on larger volume orders, as well as other products and options.

# WARRANTY

---



All MAGNETROL electronic level and flow controls are warranted free of defects in materials or workmanship for one full year from the date of original factory shipment. If returned within the warranty period; and, upon factory inspection of the control, the cause of the claim is determined to be covered under the warranty; then, MAGNETROL will repair or replace the

control at no cost to the purchaser (or owner) other than transportation.

MAGNETROL shall not be liable for misapplication, labor claims, direct or consequential damage or expense arising from the installation or use of equipment. There are no other warranties expressed or implied, except special written warranties covering some MAGNETROL products.

For additional information, see:  
THERMATEL Instruction Manual 54-610  
Hygienic Thermatel 54-160



5300 Belmont Road • Downers Grove, Illinois 60515-4499 • 630-969-4000 • Fax 630-969-9489 • [www.magnetrol.com](http://www.magnetrol.com)  
145 Jardin Drive, Units 1 & 2 • Concord, Ontario Canada L4K 1X7 • 905-738-9600 • Fax 905-738-1306  
Heikensstraat 6 • B 9240 Zele, Belgium • 052 45.11.11 • Fax 052 45.09.93  
Regent Business Ctr., Jubilee Rd. • Burgess Hill, Sussex RH15 9TL U.K. • 01444-871313 • Fax 01444-871317

Copyright © 2011 MAGNETROL INTERNATIONAL, INCORPORATED. All rights reserved. Printed in the USA.  
Performance specifications are effective with date of issue and are subject to change without notice.

MAGNETROL, MAGNETROL logotype and THERMATEL are registered trademarks of MAGNETROL INTERNATIONAL, INCORPORATED.  
CSA logotype is a registered trademark of Canadian Standards Association  
Hastelloy® is a registered trademark of Haynes International, Inc.  
Monel® and Inconel® are registered trademarks of Special Metals Corporation  
Varivent® is a registered trademark of Tuchenhagen GmbH LTD

**BULLETIN: 54-110.3**  
**EFFECTIVE: April 2010**  
**SUPERSEDES: October 2007**