

Panasonic
ideas for life

**NARROW-PITCH
CONNECTORS FOR
BOARD-TO-BOARD
CONNECTION**

**NARROW PITCH
(0.5mm) CONNECTORS
P5 SERIES — P5K, P5KS —**

• P5K

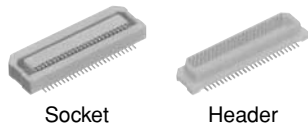

• P5KS

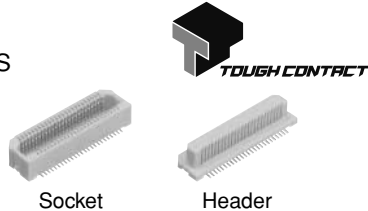

Note) The external appearance and PC board pattern differs for the P5K and P5KS series.

FEATURES

1. The product lineup consists of 3.0 mm, 3.5 mm, 4.0 mm, 4.5 mm, 5.0 mm, 5.5 mm, 6.0 mm, 6.5 mm, 7.0 mm, 8.0 mm, and 9.0 mm.

Type	Mated height	Notes
P5K	3 mm, 3.5 mm	The external appearance and PC board pattern differs for the P5K and P5KS series.
P5KS	4 mm, 4.5 mm, 5 mm, 5.5 mm, 6 mm, 6.5 mm, 7 mm, 8 mm, 9 mm	

2. Strong resistance to adverse environments! Utilizes **TOUGH CONTACT** construction for high contact reliability.

TOUGH CONTACT		P5K	P5KS
4 constructions	Bellows contact construction	○	○
	V notch construction	—	○ (Note)
	Ni barrier construction	—	○ (Note)
	Porosity treatment	○	○

Note: P5KS will support V notch and Ni barrier from November, 2005, and will have TOUGH CONTACT construction.

1) Contacts are highly resistant to shock caused by dropping and employ our original bellows contact construction.

• What is meant by “bellows type” contact?

Rather than two broken-out surfaces, the contact is formed by the surfaces of two rolled plates. This helps the contact hold up better to repeated insertions and removals, while at the same time achieving highly reliable contact.

The roll surfaces are in contact with each other, providing high contact reliability.

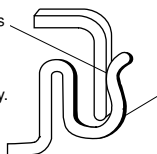

Since the contact is formed by bending thin plate, it has a spring-like quality. This construction helps make it resistant to dropping and twisting.

2) V notch construction used for excellent resistance against foreign matters. (P5KS: Available from Nov. 2005)

• What is V notch construction?

By using the edge for the contacting part and increasing contact pressure per unit area, the effectiveness in removing flux and contaminants is increased compared to its predecessor. This is also effective in preventing the trapping of contaminants.

[Cross section of contacting part]

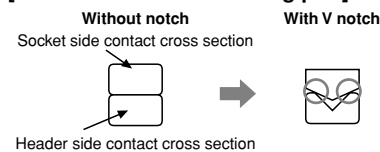

3) Use of Ni barrier construction is standard. Highly effective against solder creeping. (P5KS: Available from Nov. 2005)

• What is Ni barrier construction?

By providing an exposed nickel part on the gold (Au) plated contact, solder creeping is prevented despite the ultra low profile.

[Contact]

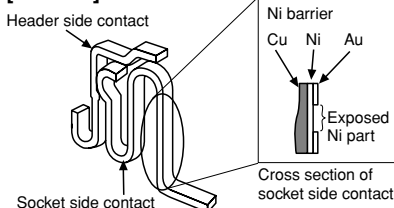

Note: Construction makes solder creeping difficult because header side is formed at the same time.

4) Porosity treatment applied for improved resistance against corrosion.

What is porosity treatment?

This treatment consists of coating the surface with a very thin film to seal pinholes in the gold plating. This porosity treatment technology ensures the same contact reliability for thin gold plating as that of thick gold plating.

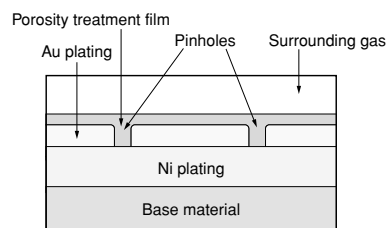

- Improvement in insertion/removal durability
- Improvement in resistance to corrosion
- Improvement in contact reliability for digital signals

3. Even with the low profile, the effective mating length has been extended to ensure that there is some latitude in the mating.

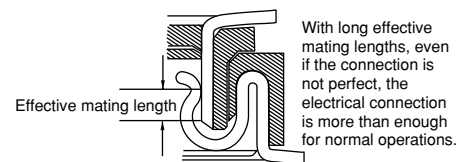

Type	Effective mating length
P5K	0.75 mm
P5KS	1.0 mm

4. Automatic mounting

1) Suction area for suction-type automatic mounting machines is employed.

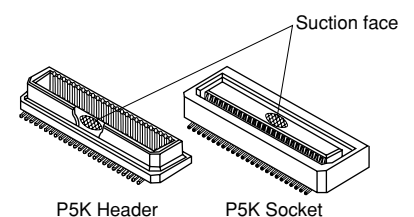

5. Compliance with RoHS' Directive Environmentally friendly, the connectors' comply with Europe's RoHS' Directive. Cadmium, lead, mercury, hexavalent, chromium, PBB and PBDE are not used.

APPLICATIONS

1. Mobile phones, PHS, mobile info-communications terminals, and other small portable devices

2. The 160-contacts connector: This connector is particularly suited to the motherboard, CPU board, and other multi-pin expansion boards on notebook PCs and other info-communications applications.

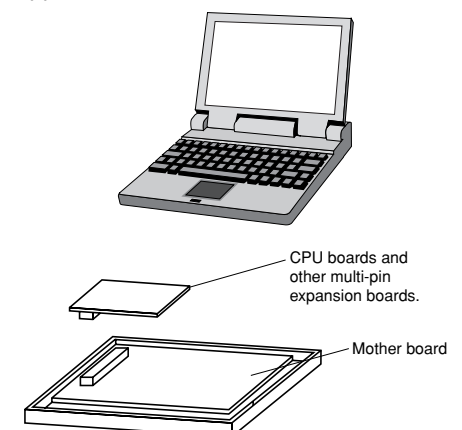

AXK(5(S)/6(S))

TABLE OF PRODUCT TYPES

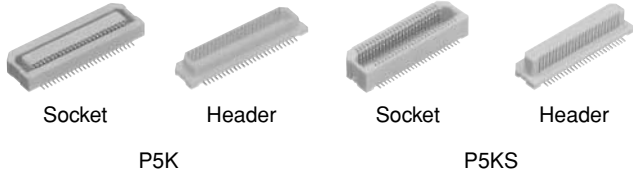

Product name		P5K		P5KS TOUGH CONTACT								
Mated height		3.0mm	3.5mm	4.0mm	4.5mm	5.0mm	5.5mm	6.0mm	6.5mm	7.0mm	8.0mm	9.0mm
		Number of contacts	20	☆	☆	☆	☆	☆	☆	☆	☆	☆
22	☆		☆									
24				☆	☆							
30	☆		☆	☆	☆	☆	☆	☆	☆	☆	☆	☆
34						☆	☆					
36					☆							
40	☆		☆	☆	☆	☆	☆	☆	☆	☆	☆	☆
50	☆		☆	☆	☆	☆	☆	☆	☆	☆	☆	☆
60	☆		☆	☆	☆	☆	☆	☆	☆	☆	☆	☆
70	☆		☆	☆	☆	☆	☆	☆	☆	☆	☆	☆
80	☆		☆	☆	☆	☆	☆	☆	☆	☆	☆	☆
100	☆		☆	☆	☆	☆	☆	☆	☆	☆	☆	☆
120	☆		☆	☆	☆							
130									☆			
160			☆	☆								

- Notes: 1. The standard type comes without positioning bosses. (Positioning bosses come standard on types with 4.0 mm and 4.5 mm mated height with 120 and 160 contacts, and 6.5 mm mated height with 130 contacts.) Connectors with positioning boss are available for on-demand production.
 2. Please consult us for products which have no ☆ mark.

ORDERING INFORMATION

1. P5K (3.0 mm and 3.5 mm)

AXK

- 5: Narrow Pitch Connector P5K Socket
 6: Narrow Pitch Connector P5K Header

Number of contacts (2 digits)

Mated height

<Socket>

- 1: For mated height 3.0 mm and 3.5 mm

<Header>

- 2: For mated height 3.5 mm
 3: For mated height 3.0 mm

Functions

- 3: With positioning bosses
 4: Without positioning bosses

Surface treatment (Contact portion / Terminal portion)

- 5: Ni plating on base, Au plating on surface / Ni plating on base, Au plating on surface

Packing

- J: 1,500 pieces embossed tape and paper reel × 2
 P: 1,000 pieces embossed tape and paper reel × 2

2. P5KS (4.0 mm, 4.5 mm, 5.0 mm, 5.5 mm, 6.0 mm, 6.5 mm, 7.0 mm, 8.0 mm and 9.0 mm)

AXK

5S: Narrow Pitch Connector P5KS Socket
6S: Narrow Pitch Connector P5KS Header

Number of contacts (2 digits)

Mated height

<Socket>

0: For mated height 4.0 mm, 5.0 mm and 6.0 mm

2: For mated height 4.5 mm, 5.5 mm and 6.5 mm

3: For mated height 7.0 mm, 8.0 mm and 9.0 mm

<Header>

4: For mated height 4.0 mm, 4.5 mm and 7.0 mm

5: For mated height 5.0 mm, 5.5 mm and 8.0 mm

6: For mated height 6.0 mm, 6.5 mm and 9.0 mm

Functions

3: With positioning boss and direction for protection from reverse mating

4: Without positioning boss/with direction for protection from reverse mating

7: With positioning boss/without direction for protection from reverse mating

8: Without positioning boss and direction for protection from reverse mating

Surface treatment (Contact portion / Terminal portion)

0: Ni plating on base, Au plating on surface / Ni plating on base, Au plating on surface
(Previous model: Ni plating on base, SnPb plating on surface of terminal portion)

5: Ni plating on base, Au plating on surface / Ni plating on base, Au plating on surface

7: Ni plating on base, Au plating on surface / Ni plating on base, Au plating on surface
(for Ni barrier product available from Nov. 2005)

Contact portion

<Socket>

Nil: Without V notch product

Y: V notch type product (chamfered on both sides) (Available from Nov. 2005)

<Header>

Nil: Without V notch product

Y: V notch type product (Available from Nov. 2005)

Packing

G: 1,500 pieces embossed tape and plastic reel × 2

(Socket: Mated heights 4.0 mm, 4.5 mm, 5.0 mm, 5.5 mm, 6.0 mm, 6.5 mm)
(Header: Mated heights 4.0 mm, 4.5 mm, 7.0 mm)

1,000 pieces plastic reel × 2

(Socket: Mated heights 7.0 mm, 8.0 mm, 9.0 mm)
(Header: Mated heights 5.0 mm, 5.5 mm, 6.0 mm, 6.5 mm, 8.0 mm, 9.0 mm)

J: 1,500 pieces embossed tape and paper reel × 2

P: 1,000 pieces embossed tape and paper reel × 2

Notes: 1. Models with mating directionality to prevent reverse insertion have over 100 contacts. Models without mating directionality to prevent reverse insertion have less than 100 contacts.

2. The plating on the solder terminal portion has changed from SnPb to Au plating from the production lot of December, 2002, in order to eliminate lead.

3. Only "J" and "P" are supported as packaging specifications for models without Ni barrier. The packaging specification for Ni barrier models is "G" only.

Models possible for "J" are as follows:

Sockets: Mated heights 4.0 mm, 4.5 mm, 5.0 mm, 5.5 mm, 6.0 mm, and 6.5 mm

Headers: Mated heights 4.0 mm, 4.5 mm, and 7.0 mm

AXK(5(S)/6(S))

PRODUCT TYPES

1. P5K

Product name	Mated height	No. of contacts	Part No.		Packing		
			Socket	Header	Inner carton (1 reel)	Outer carton	
P5K	3.0 mm	20	AXK520145J	AXK620345J	1,500 pieces ^{Note 1)}	3,000 pieces ^{Note 1)}	
		22	AXK522145J	AXK622345J			
		30	AXK530145J	AXK630345J			
		40	AXK540145J	AXK640345J			
		50	AXK550145J	AXK650345J			
		60	AXK560145J	AXK660345J			
		70	AXK570145J	AXK670345J			
		80	AXK580145J	AXK680345J			
		100	AXK500145J	AXK600345J			
		120	AXK5A2145J	AXK6A2345J			
		3.5 mm	20	AXK520145J			AXK620245J
			22	AXK522145J			AXK622245J
	30		AXK530145J	AXK630245J			
	40		AXK540145J	AXK640245J			
	50		AXK550145J	AXK650245J			
	60		AXK560145J	AXK660245J			
	70		AXK570145J	AXK670245J			
	80		AXK580145J	AXK680245J			
	100		AXK500145J	AXK600245J			
	120		AXK5A2145J	AXK6A2245J			

- Notes) 1. For the protection of our environment, orders of J: Inner carton (1 reel) 1,500 pcs. units are recommended to reduce packaging materials.
 In addition, orders of P: Inner carton (1 reel) 1,000 pcs. units with embossed tape packaging are also available; to order change the suffix "J" to the suffix "P"
2. Regarding ordering units: During production: Please make orders in 1 reel units.
 Samples for mounting confirmation: Available in units of 50 pieces. Please consult us. (See "Regarding sample orders to confirm proper mounting" on page 13.)
 Samples: Small lot orders are possible. Change the suffix "J" to the suffix "P".
3. The standard type comes without positioning bosses.
 Connectors with positioning bosses are available on-demand production. For P5K type of 8th digit of the part no. changes from 4 to 3.
 e.g. Mated height 3.0 mm, 20 contacts for sockets: AXK520135P

2. P5KS

Product name	Mated height	No. of contacts	Part No.				Packing	
			Socket		Header		Inner carton (1 reel)	Outer carton
			Without V notch and Ni barrier product (Paper reel)	TOUGH CONTACT (Paper reel) (Recommendation)	Without V notch and Ni barrier product (Paper reel)	TOUGH CONTACT (Paper reel) (Recommendation)		
P5KS	4.0 mm	20	AXK5S20045*	AXK5S20047YG (From Nov. 2005)	AXK6S20445*	AXK6S20447YG (From Nov. 2005)	Note 2 "Asterisk" mark on end of part No.; J: 1,500 pieces P: 1,000 pieces	Note 2 "Asterisk" mark on end of part No.; J: 3,000 pieces P: 2,000 pieces
		24	AXK5S24045*	AXK5S24047YG (From Nov. 2005)	AXK6S24445*	AXK6S24447YG (From Nov. 2005)		
		30	AXK5S30045*	AXK5S30047YG (From Nov. 2005)	AXK6S30445*	AXK6S30447YG (From Nov. 2005)		
		40	AXK5S40045*	AXK5S40047YG (From Nov. 2005)	AXK6S40445*	AXK6S40447YG (From Nov. 2005)		
		50	AXK5S50045*	AXK5S50047YG (From Nov. 2005)	AXK6S50445*	AXK6S50447YG (From Nov. 2005)		
		60	AXK5S60045*	AXK5S60047YG (From Nov. 2005)	AXK6S60445*	AXK6S60447YG (From Nov. 2005)		
		70	AXK5S70045*	AXK5S70047YG (From Nov. 2005)	AXK6S70445*	AXK6S70447YG (From Nov. 2005)		
		80	AXK5S80045*	AXK5S80047YG (From Nov. 2005)	AXK6S80445*	AXK6S80447YG (From Nov. 2005)		
		100	AXK5S00045*	AXK5S00047YG (From Nov. 2005)	AXK6S00445*	AXK6S00447YG (From Nov. 2005)		
		120	AXK5SA2075*	AXK5SA2077YG (From Nov. 2005)	AXK6SA2475*	AXK6SA2477YG (From Nov. 2005)		
	160	AXK5SA6075*	AXK5SA6077YG (From Nov. 2005)	AXK6SA6475*	AXK6SA6477YG (From Nov. 2005)			
	4.5 mm	20	AXK5S20245*	AXK5S20247YG (From Nov. 2005)	AXK6S20445*	AXK6S20447YG (From Nov. 2005)	"G" mark on end of part No.; 1,500 pieces	"G" mark on end of part No.; 3,000 pieces
		24	AXK5S24245*	AXK5S24247YG (From Nov. 2005)	AXK6S24445*	AXK6S24447YG (From Nov. 2005)		
		30	AXK5S30245*	AXK5S30247YG (From Nov. 2005)	AXK6S30445*	AXK6S30447YG (From Nov. 2005)		
		36	AXK5S36245*	AXK5S36247YG (From Nov. 2005)	AXK6S36445*	AXK6S36447YG (From Nov. 2005)		
		40	AXK5S40245*	AXK5S40247YG (From Nov. 2005)	AXK6S40445*	AXK6S40447YG (From Nov. 2005)		
		50	AXK5S50245*	AXK5S50247YG (From Nov. 2005)	AXK6S50445*	AXK6S50447YG (From Nov. 2005)		
		60	AXK5S60245*	AXK5S60247YG (From Nov. 2005)	AXK6S60445*	AXK6S60447YG (From Nov. 2005)		
		70	AXK5S70245*	AXK5S70247YG (From Nov. 2005)	AXK6S70445*	AXK6S70447YG (From Nov. 2005)		
		80	AXK5S80245*	AXK5S80247YG (From Nov. 2005)	AXK6S80445*	AXK6S80447YG (From Nov. 2005)		
		100	AXK5S00245*	AXK5S00247YG (From Nov. 2005)	AXK6S00445*	AXK6S00447YG (From Nov. 2005)		
	5.0 mm	20	AXK5S20045*	AXK5S20047YG (From Nov. 2005)	AXK6S20545P	AXK6S20547YG (From Nov. 2005)	Note 2 "Asterisk" mark on end of part No.; J: 1,500 pieces P: 1,000 pieces	Note 2 "Asterisk" mark on end of part No.; J: 3,000 pieces P: 2,000 pieces
		30	AXK5S30045*	AXK5S30047YG (From Nov. 2005)	AXK6S30545P	AXK6S30547YG (From Nov. 2005)		
		34	AXK5S34045*	AXK5S34047YG (From Nov. 2005)	AXK6S34545P	AXK6S34547YG (From Nov. 2005)		
		40	AXK5S40045*	AXK5S40047YG (From Nov. 2005)	AXK6S40545P	AXK6S40547YG (From Nov. 2005)		
		50	AXK5S50045*	AXK5S50047YG (From Nov. 2005)	AXK6S50545P	AXK6S50547YG (From Nov. 2005)		
		60	AXK5S60045*	AXK5S60047YG (From Nov. 2005)	AXK6S60545P	AXK6S60547YG (From Nov. 2005)		
		70	AXK5S70045*	AXK5S70047YG (From Nov. 2005)	AXK6S70545P	AXK6S70547YG (From Nov. 2005)		
		80	AXK5S80045*	AXK5S80047YG (From Nov. 2005)	AXK6S80545P	AXK6S80547YG (From Nov. 2005)		
		100	AXK5S00045*	AXK5S00047YG (From Nov. 2005)	AXK6S00545P	AXK6S00547YG (From Nov. 2005)		
						Socket: 1,500 pieces Header: 1,000 pieces		

AXK(5(S)/6(S))

Product name	Mated height	No. of contacts	Part No.				Packing	
			Socket		Header		Inner carton (1 reel)	Outer carton
			Without V notch and Ni barrier product (Paper reel)	TOUGH CONTACT (Paper reel) (Recommendation)	Without V notch and Ni barrier product (Paper reel)	TOUGH CONTACT (Paper reel) (Recommendation)		
P5KS	5.5 mm	20	AXK5S20245*	AXK5S20247YG (From Nov. 2005)	AXK6S20545P	AXK6S20547YG (From Nov. 2005)	Note 2) "Asterisk" mark on end of part No.; J: 1,500 pieces P: 1,000 pieces "G" mark on end of part No.; Socket: 1,500 pieces Header: 1,000 pieces	Note 2) "Asterisk" mark on end of part No.; J: 3,000 pieces P: 2,000 pieces "G" mark on end of part No.; Socket: 3,000 pieces Header: 2,000 pieces
		30	AXK5S30245*	AXK5S30247YG (From Nov. 2005)	AXK6S30545P	AXK6S30547YG (From Nov. 2005)		
		34	AXK5S34245*	AXK5S34247YG (From Nov. 2005)	AXK6S34545P	AXK6S34547YG (From Nov. 2005)		
		40	AXK5S40245*	AXK5S40247YG (From Nov. 2005)	AXK6S40545P	AXK6S40547YG (From Nov. 2005)		
		50	AXK5S50245*	AXK5S50247YG (From Nov. 2005)	AXK6S50545P	AXK6S50547YG (From Nov. 2005)		
		60	AXK5S60245*	AXK5S60247YG (From Nov. 2005)	AXK6S60545P	AXK6S60547YG (From Nov. 2005)		
		70	AXK5S70245*	AXK5S70247YG (From Nov. 2005)	AXK6S70545P	AXK6S70547YG (From Nov. 2005)		
		80	AXK5S80245*	AXK5S80247YG (From Nov. 2005)	AXK6S80545P	AXK6S80547YG (From Nov. 2005)		
		100	AXK5S00245*	AXK5S00247YG (From Nov. 2005)	AXK6S00545P	AXK6S00547YG (From Nov. 2005)		
	6.0 mm	20	AXK5S20045*	AXK5S20047YG (From Nov. 2005)	AXK6S20645P	AXK6S20647YG (From Nov. 2005)		
		30	AXK5S30045*	AXK5S30047YG (From Nov. 2005)	AXK6S30645P	AXK6S30647YG (From Nov. 2005)		
		40	AXK5S40045*	AXK5S40047YG (From Nov. 2005)	AXK6S40645P	AXK6S40647YG (From Nov. 2005)		
		50	AXK5S50045*	AXK5S50047YG (From Nov. 2005)	AXK6S50645P	AXK6S50647YG (From Nov. 2005)		
		60	AXK5S60045*	AXK5S60047YG (From Nov. 2005)	AXK6S60645P	AXK6S60647YG (From Nov. 2005)		
		70	AXK5S70045*	AXK5S70047YG (From Nov. 2005)	AXK6S70645P	AXK6S70647YG (From Nov. 2005)		
		80	AXK5S80045*	AXK5S80047YG (From Nov. 2005)	AXK6S80645P	AXK6S80647YG (From Nov. 2005)		
		100	AXK5S00045*	AXK5S00047YG (From Nov. 2005)	AXK6S00645P	AXK6S00647YG (From Nov. 2005)		
		6.5 mm	20	AXK5S20245*	AXK5S20247YG (From Nov. 2005)	AXK6S20645P		
	30		AXK5S30245*	AXK5S30247YG (From Nov. 2005)	AXK6S30645P	AXK6S30647YG (From Nov. 2005)		
	40		AXK5S40245*	AXK5S40247YG (From Nov. 2005)	AXK6S40645P	AXK6S40647YG (From Nov. 2005)		
	50		AXK5S50245*	AXK5S50247YG (From Nov. 2005)	AXK6S50645P	AXK6S50647YG (From Nov. 2005)		
	60		AXK5S60245*	AXK5S60247YG (From Nov. 2005)	AXK6S60645P	AXK6S60647YG (From Nov. 2005)		
	70		AXK5S70245*	AXK5S70247YG (From Nov. 2005)	AXK6S70645P	AXK6S70647YG (From Nov. 2005)		
	80		AXK5S80245*	AXK5S80247YG (From Nov. 2005)	AXK6S80645P	AXK6S80647YG (From Nov. 2005)		
	100		AXK5S00245*	AXK5S00247YG (From Nov. 2005)	AXK6S00645P	AXK6S00647YG (From Nov. 2005)		
	130		AXK5SA3275*	AXK5SA3277YG (From Nov. 2005)	AXK6SA3675P	AXK6SA3677YG (From Nov. 2005)		
	7.0 mm	20	AXK5S20340P	AXK5S20347YG (From Nov. 2005)	AXK6S20445*	AXK6S20447YG (From Nov. 2005)		
		30	AXK5S30340P	AXK5S30347YG (From Nov. 2005)	AXK6S30445*	AXK6S30447YG (From Nov. 2005)		
		40	AXK5S40340P	AXK5S40347YG (From Nov. 2005)	AXK6S40445*	AXK6S40447YG (From Nov. 2005)		
		50	AXK5S50340P	AXK5S50347YG (From Nov. 2005)	AXK6S50445*	AXK6S50447YG (From Nov. 2005)		
60		AXK5S60340P	AXK5S60347YG (From Nov. 2005)	AXK6S60445*	AXK6S60447YG (From Nov. 2005)			
70		AXK5S70340P	AXK5S70347YG (From Nov. 2005)	AXK6S70445*	AXK6S70447YG (From Nov. 2005)			
80		AXK5S80340P	AXK5S80347YG (From Nov. 2005)	AXK6S80445*	AXK6S80447YG (From Nov. 2005)			
100		AXK5S00340P	AXK5S00347YG (From Nov. 2005)	AXK6S00445*	AXK6S00447YG (From Nov. 2005)			

Product name	Mated height	No. of contacts	Part No.				Packing	
			Socket		Header		Inner carton (1 reel)	Outer carton
			Without V notch and Ni barrier product (Paper reel)	<i>TOUGH CONTACT</i> (Paper reel) (Recommendation)	Without V notch and Ni barrier product (Paper reel)	<i>TOUGH CONTACT</i> (Paper reel) (Recommendation)		
P5KS	8.0 mm	20	AXK5S20340P	AXK5S20347YG (From Nov. 2005)	AXK6S20545P	AXK6S20547YG (From Nov. 2005)	1,000 pieces	2,000 pieces
		30	AXK5S30340P	AXK5S30347YG (From Nov. 2005)	AXK6S30545P	AXK6S30547YG (From Nov. 2005)		
		40	AXK5S40340P	AXK5S40347YG (From Nov. 2005)	AXK6S40545P	AXK6S40547YG (From Nov. 2005)		
		50	AXK5S50340P	AXK5S50347YG (From Nov. 2005)	AXK6S50545P	AXK6S50547YG (From Nov. 2005)		
		60	AXK5S60340P	AXK5S60347YG (From Nov. 2005)	AXK6S60545P	AXK6S60547YG (From Nov. 2005)		
		70	AXK5S70340P	AXK5S70347YG (From Nov. 2005)	AXK6S70545P	AXK6S70547YG (From Nov. 2005)		
		80	AXK5S80340P	AXK5S80347YG (From Nov. 2005)	AXK6S80545P	AXK6S80547YG (From Nov. 2005)		
		100	AXK5S00340P	AXK5S00347YG (From Nov. 2005)	AXK6S00545P	AXK6S00547YG (From Nov. 2005)		
	9.0 mm	20	AXK5S20340P	AXK5S20347YG (From Nov. 2005)	AXK6S20645P	AXK6S20647YG (From Nov. 2005)		
		30	AXK5S30340P	AXK5S30347YG (From Nov. 2005)	AXK6S30645P	AXK6S30647YG (From Nov. 2005)		
		40	AXK5S40340P	AXK5S40347YG (From Nov. 2005)	AXK6S40645P	AXK6S40647YG (From Nov. 2005)		
		50	AXK5S50340P	AXK5S50347YG (From Nov. 2005)	AXK6S50645P	AXK6S50647YG (From Nov. 2005)		
		60	AXK5S60340P	AXK5S60347YG (From Nov. 2005)	AXK6S60645P	AXK6S60647YG (From Nov. 2005)		
		70	AXK5S70340P	AXK5S70347YG (From Nov. 2005)	AXK6S70645P	AXK6S70647YG (From Nov. 2005)		
		80	AXK5S80340P	AXK5S80347YG (From Nov. 2005)	AXK6S80645P	AXK6S80647YG (From Nov. 2005)		
		100	AXK5S00340P	AXK5S00347YG (From Nov. 2005)	AXK6S00645P	AXK6S00647YG (From Nov. 2005)		

- Notes) 1. Regarding ordering units: During production: Please make orders in 1 reel units.
 Samples for mounting confirmation: Available in units of 50 pieces. Please consult us. (See "Regarding sample orders to confirm proper mounting" on page 13.)
 Samples: Small lot orders are possible. For models without V notch and Ni barrier, change the suffix "J" to the suffix "P" or place a "P" where the "*" is located.
 For V notch and Ni barrier models add "G" at the end of the part number.
2. The standard type comes without positioning bosses (However, mated heights of 4 mm or higher and 120 pins or more comes standard with bosses). Connectors with positioning bosses are available for on-demand production. For P5KS type of 9th digit of the part no. changes from 4 to 3.
 e.g. Mated height 4.0 mm, 20 contacts for sockets: AXK5S20037G

AXK(5(S)/6(S))

SPECIFICATIONS

1. Characteristics

Item	Specifications			Conditions
	3mm, 3.5mm type	4mm, 4.5mm, 5mm, 5.5mm, 6mm, 6.5mm type	7mm, 8mm, 9mm type	
Electrical characteristics	Rated current	0.5A/terminal (Max. 10A)	0.5A/terminal (Max. 16A)	
	Rated voltage	60V AC/DC		
	Breakdown voltage	150V AC for 1 min.		Detection current: 1mA
	Insulation resistance	Min. 1000MΩ		Using 500V DC megger
	Contact resistance	Max. 60mΩ	Max. 80mΩ	Measured based on the HP4338B measurement method of JIS C 5402
Mechanical characteristics	Composite insertion force	Max. 0.785N {80gf} × no. of contacts (initial)		
	Composite removal force	Min. 0.0588N {6gf} × no. of contacts		
	Post holding force	Min. 0.98N {100gf}/contacts		Measures the maximum load in the post axial direction until removal
Environmental characteristics	Ambient temperature	-55°C to +85°C		No freezing at low temperatures
	Soldering heat resistance	Max. peak temperature of 245°C		Infrared reflow soldering
		300°C within 5 sec.		Soldering iron
	Thermal shock resistance (header and socket mated)	5 cycles, insulation resistance min. 100MΩ, contact resistance max. 60mΩ	5 cycles, insulation resistance min. 100MΩ, contact resistance max. 80mΩ	Sequence 1. -55 $\frac{3}{3}$ °C, 30 minutes 2. ~, Max. 5 minutes 3. 85 $\frac{3}{3}$ °C, 30 minutes 4. ~, Max. 5 minutes
	Humidity resistance (header and socket mated)	120 hours, insulation resistance min. 100MΩ, contact resistance max. 60mΩ	120 hours, insulation resistance min. 100MΩ, contact resistance max. 80mΩ	Bath temperature 40±2°C, humidity 90 to 95% R.H.
	Saltwater spray resistance (header and socket mated)	24 hours, insulation resistance min. 100MΩ, contact resistance max. 60mΩ	24 hours, insulation resistance min. 100MΩ, contact resistance max. 80mΩ	Bath temperature 35±2°C, saltwater concentration 5±1%
H ₂ S resistance (header and socket mated)	48 hours, contact resistance max. 60mΩ	48 hours, contact resistance max. 80mΩ	Bath temperature 40±2°C, gas concentration 3±1 ppm, humidity 75 to 80% R.H.	
Lifetime characteristics	Insertion and removal life	50 times		Repeated insertion and removal speed of max. 200 times/hours
Unit weight	P5K 3mm 30 contacts P5KS 4mm 30 contacts	Socket: 0.17g Header: 0.09g	Socket: 0.18g Header: 0.16g	

2. Material and surface treatment

Part name	Mated height 3mm, 3.5mm, 4mm, 4.5mm, 5mm, 5.5mm, 6mm, 6.5mm, 7mm, 8mm, 9mm	
	Material	Surface treatment
Molded portion	Heat-resistant resin (UL94V-0)	—
Contact/post	Copper alloy	Contact portion: Ni plating on base, Au plating on surface Terminal portion: Ni plating on base, Au plating on surface (Except for thick of terminal) However, the area adjacent to the terminal on Ni barrier models is exposed to Ni on base.

DIMENSIONS

mm General tolerance: ±0.2

P5K: Mated height 3mm, 3.5mm type

• Socket



Dimension table (mm)

No. of contacts	A	B
20	8.20	4.50
22	8.70	5.00
30	10.70	7.00
40	13.20	9.50
50	15.70	12.00
60	18.20	14.50
70	20.70	17.00
80	23.20	19.50
100	28.20	24.50
120	33.20	29.50

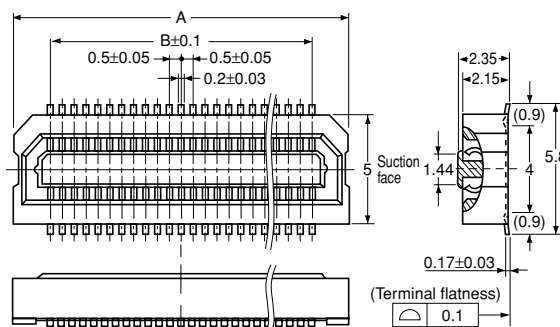

• Header



Dimension table (mm)

No. of contacts	A	B
20	8.20	4.50
22	8.70	5.00
30	10.70	7.00
40	13.20	9.50
50	15.70	12.00
60	18.20	14.50
70	20.70	17.00
80	23.20	19.50
100	28.20	24.50
120	33.20	29.50

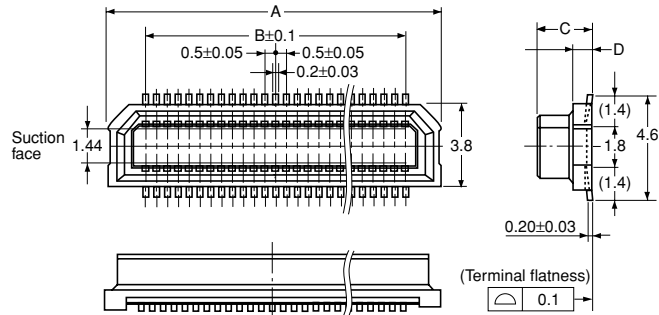

Mated height	C	D
3.0 mm	2.4	0.85
3.5 mm	2.9	1.35

• Socket and header are mated

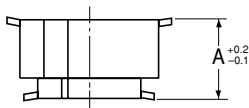

Mated height	A
3.0 mm	3.0
3.5 mm	3.5

Note) P5KS series (mated heights 4.0mm, 4.5mm, 5.0mm, 5.5mm, 6.0mm, 6.5mm, 7.0mm, 8.0mm, and 9.0mm) cannot be mated to this type.

P5KS: Mated height 4.0mm, 4.5mm, 5.0mm, 5.5mm, 6.0mm, 6.5mm, 7.0mm, 8.0mm, 9.0mm type

• Socket



Dimension table (mm)

No. of contacts	A	B
20	8.20	4.50
24	9.20	5.50
30	10.70	7.00
34	11.70	8.00
36	12.20	8.50
40	13.20	9.50
50	15.70	12.00
60	18.20	14.50
70	20.70	17.00
80	23.20	19.50
100	28.20	24.50

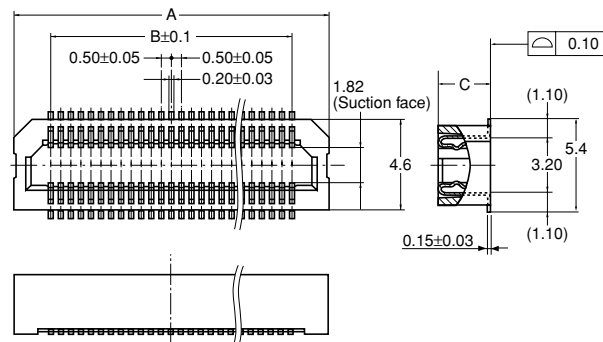

Mated height	C
4.0 mm, 5.0 mm, 6.0 mm	3.05
4.5 mm, 5.5 mm, 6.5 mm	3.55
7.0 mm, 8.0 mm, 9.0 mm	6.05

• Header



Dimension table (mm)

No. of contacts	A	B
20	8.20	4.50
24	9.20	5.50
30	10.70	7.00
34	11.70	8.00
36	12.20	8.50
40	13.20	9.50
50	15.70	12.00
60	18.20	14.50
70	20.70	17.00
80	23.20	19.50
100	28.20	24.50

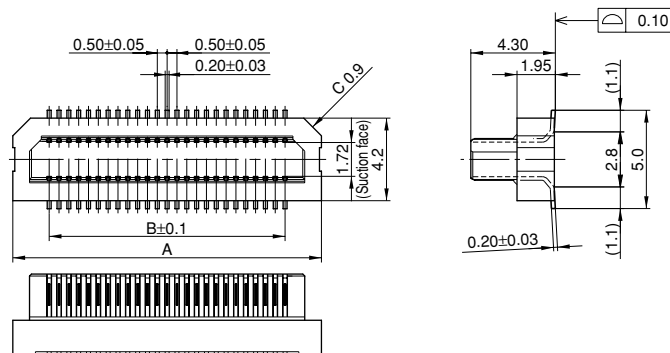

Mated height	C	D
4.0 mm, 4.5 mm, 7.0 mm	0.95	3.3
5.0 mm, 5.5 mm, 8.0 mm	1.95	4.3
6.0 mm, 6.5 mm, 9.0 mm	2.95	5.3

AXK(5(S)/6(S))

• Socket and header are mated

mm General tolerance: ± 0.2

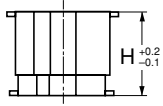

Mated height	H
4.0 mm	4.0
4.5 mm	4.5
5.0 mm	5.0
5.5 mm	5.5
6.0 mm	6.0
6.5 mm	6.5
7.0 mm	7.0
8.0 mm	8.0
9.0 mm	9.0

Note) P5K series (mated heights 3.0mm, 3.5mm) cannot be mated to this type.

P5KS: Mated height 4.0mm, 4.5mm for 120 contacts and 160 contacts types, 6.5mm for 130 contacts type

• Socket

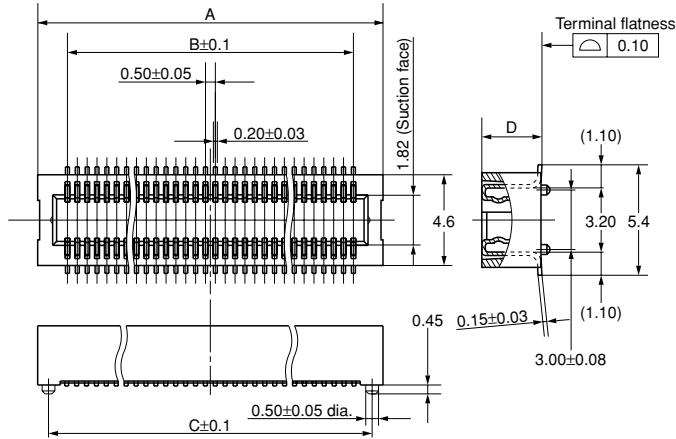

No. of contacts	A	B	C
120	32.50	29.50	32.00
130	35.00	32.00	34.50
160	42.50	39.50	42.00

Mated height	D
4.0 mm	3.05
4.5 mm, 6.5 mm	3.55

• Header

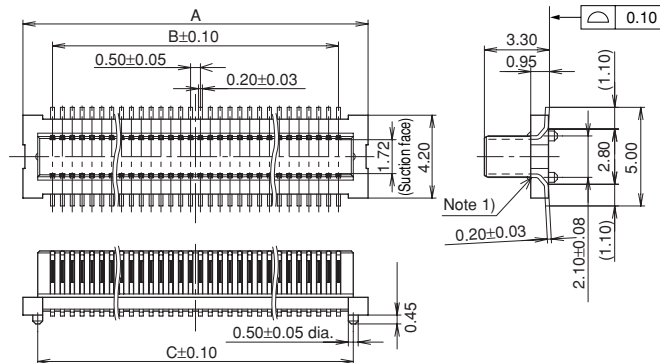
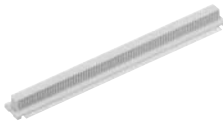

No. of contacts	A	B	C
120	32.50	29.50	31.00
130	35.00	32.00	33.50
160	42.50	39.50	41.00

Mated height	D	E
4.0 mm, 4.5 mm	3.30	0.95
6.5 mm	5.30	2.95

• Socket and header are mated

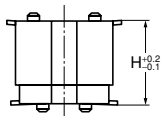

Mated height	H
4.0 mm	4.0
4.5 mm	4.5
6.5 mm	6.5

Notes) 1. Inquiry separately for diagrams of the embossed tape and cautions for use.
2. Be sure to ask for proper specifications and drawings before actual use.

EMBOSSED TAPE DIMENSIONS (unit:mm, Common for respective contact type, socket and header)

• Tape dimensions (Conforming to JIS C 0806-1990.
However, some tapes have mounting hole pitches that do not comply with the standard.)

• Plastic reel dimensions (Conforming to EIAJ ET-7200B)/
Paper reel dimensions (Conforming to JIS C 0806-1990)

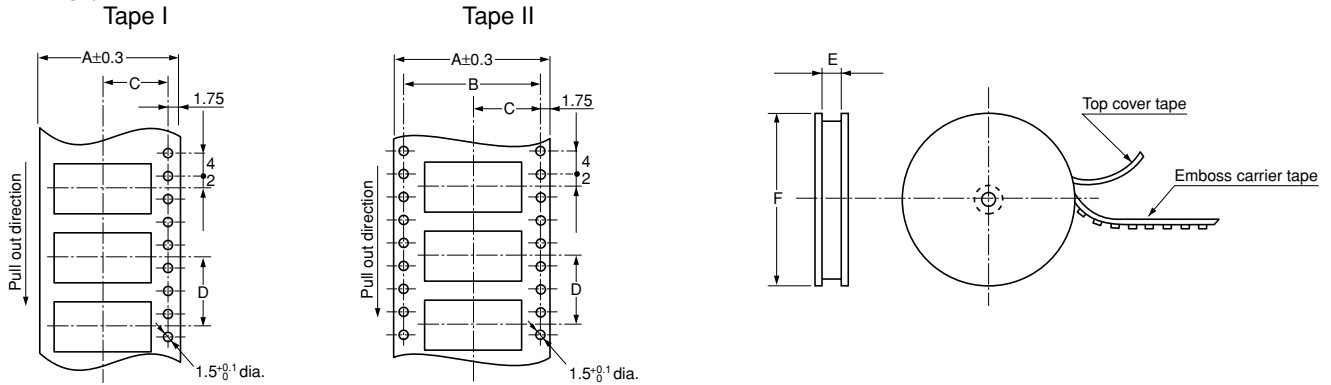

Dimension table (mm)

(1) Suffix: G (1 reel, 1,500 pieces or 1,000 pieces embossed tape and plastic reel package)

Type	Mated height	No. of contacts	Type of taping	A	B	C	D	E	F	Quantity per reel
P5KS	Socket: 4.0mm, 4.5mm, 5.0mm, 5.5mm, 6.0mm, 6.5mm Header: 4.0mm, 4.5mm, 7.0mm	20 to 50	Tape I	24.0	—	11.5	12.0	25.4±1	380 dia.	1,500 pcs.
		60 to 70	Tape II	32.0	28.4	14.2	12.0	33.4±1	380 dia.	
		80 to 100	Tape II	44.0	40.4	20.2	12.0	45.4±1	380 dia.	
		120 to 160	Tape II	56.0	52.4	26.2	12.0	57.4±1	380 dia.	
P5KS	Socket: 7.0mm, 8.0mm, 9.0mm Header: 5.0mm, 5.5mm, 6.0mm, 6.5mm, 8.0mm, 9.0mm	20 to 50	Tape I	24.0	—	11.5	12.0	25.4±1	380 dia.	1,000 pcs.
		60 to 70	Tape II	32.0	28.4	14.2	12.0	33.4±1	380 dia.	
		80 to 100	Tape II	44.0	40.4	20.2	12.0	45.4±1	380 dia.	
		130	Tape II	56.0	52.4	26.2	12.0	57.4±1	380 dia.	

(2) Suffix: J (1 reel, 1,500 pieces embossed tape and paper reel package)



Type	Mated height	No. of contacts	Type of taping	A	B	C	D	E	F	Quantity per reel
P5K	Socket and header are common 3.0mm, 3.5mm	20 to 50	Tape I	24.0	—	11.5	12.0	24.4 ^{+2/0}	370 dia.	1,500 pcs.
		60 to 70	Tape II	32.0	28.4	14.2	12.0	32.4 ^{+2/0}	370 dia.	
		80 to 100	Tape II	44.0	40.4	20.2	12.0	44.4 ^{+2/0}	370 dia.	
		120	Tape II	56.0	52.4	26.2	12.0	56.4 ^{+2/0}	370 dia.	
P5KS	Socket: 4.0mm, 4.5mm, 5.0mm, 5.5mm, 6.0mm, 6.5mm Header: 4.0mm, 4.5mm, 7.0mm	20 to 50	Tape I	24.0	—	11.5	12.0	24.4 ^{+2/0}	370 dia.	1,500 pcs.
		60 to 70	Tape II	32.0	28.4	14.2	12.0	32.4 ^{+2/0}	370 dia.	
		80 to 100	Tape II	44.0	40.4	20.2	12.0	44.4 ^{+2/0}	370 dia.	
		120 to 160	Tape II	56.0	52.4	26.2	12.0	56.4 ^{+2/0}	370 dia.	

(3) Suffix: P (1 reel, 1,000 pieces embossed tape and paper reel package)

Type	Mated height	No. of contacts	Type of taping	A	B	C	D	E	F	Quantity per reel	
P5K	Socket and header are common 3.0mm, 3.5mm	20 to 50	Tape I	24.0	—	11.5	12.0	24.4 ^{+2/0}	330 dia.	1,000 pcs.	
		60 to 70	Tape II	32.0	28.4	14.2	12.0	32.4 ^{+2/0}	330 dia.		
		80 to 100	Tape II	44.0	40.4	20.2	12.0	44.4 ^{+2/0}	330 dia.		
		120	Tape II	56.0	52.4	26.2	12.0	56.4 ^{+2/0}	330 dia.		
P5KS	Socket: 4.0mm, 4.5mm, 5.0mm, 5.5mm, 6.0mm, 6.5mm Header: 4.0mm, 4.5mm, 5.0mm, 5.5mm, 7.0mm, 8.0mm	20 to 50	Tape I	24.0	—	11.5	12.0	24.4 ^{+2/0}	330 dia.	1,000 pcs.	
		60 to 70	Tape II	32.0	28.4	14.2	12.0	32.4 ^{+2/0}	330 dia.		
		80 to 100	Tape II	44.0	40.4	20.2	12.0	44.4 ^{+2/0}	330 dia.		
		120 to 160	Tape II	56.0	52.4	26.2	12.0	56.4 ^{+2/0}	330 dia.		
	P5KS	Socket: 7.0mm, 8.0mm, 9.0mm Header: 6.0mm, 6.5mm, 9.0mm	20 to 50	Tape I	24.0	—	11.5	12.0	24.4 ^{+2/0}		370 dia.
			60 to 70	Tape II	32.0	28.4	14.2	12.0	32.4 ^{+2/0}		370 dia.
			80 to 100	Tape II	44.0	40.4	20.2	12.0	44.4 ^{+2/0}		370 dia.
			130	Tape II	56.0	52.4	26.2	12.0	56.4 ^{+2/0}		370 dia.

AXK(5(S)/6(S))

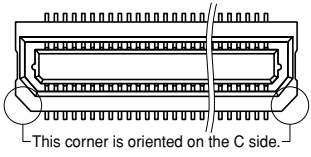
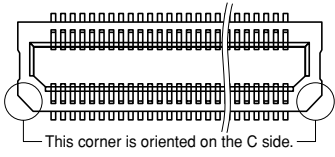
Connector orientation with respect to direction of progress of embossed tape

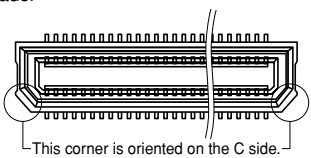
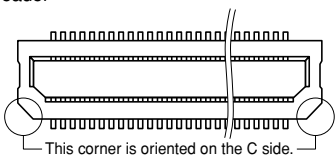
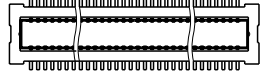
Direction of tape progress	Type	P5K	P5KS (Less than 100 contacts)	P5KS 120, 130, 160 contacts
	Socket	 <p>This corner is oriented on the C side.</p>	 <p>This corner is oriented on the C side.</p>	
	Header	 <p>This corner is oriented on the C side.</p>	 <p>This corner is oriented on the C side.</p>	 <p>Note: There is no indication on this product regarding top-bottom or left-right orientation.</p>

NOTES

1. Prevention of reverse mating

Other than 120, 130, 160 contacts type, the socket and header are protected from reverse mating by a molded resin key. Excessive mating force may damage the key, so be sure to match chamfered corners when mating.

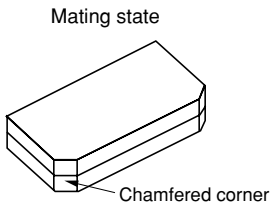
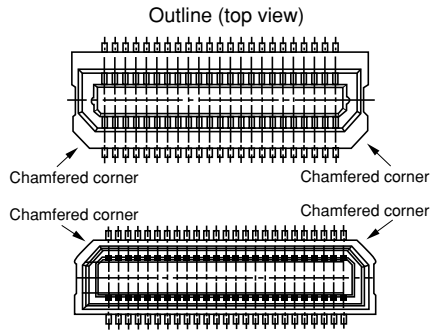

2. PC Boards and Recommended Metal Mask Patterns

Connectors are mounted with high density, with a pitch interval of 0.4 to 0.5 mm. It is therefore necessary to make sure that the right levels of solder are used, in order to reduce solder bridge and other issues. The figures to the right are recommended metal mask patterns. Please use them as a reference.

• P5K Socket

Recommended PC board pattern (TOP VIEW)

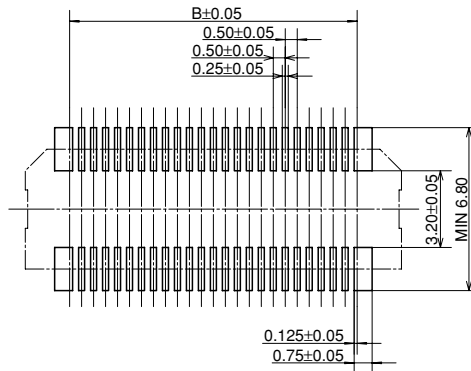

Recommended metal mask pattern
Metal mask thickness: Here, 150 μm
(Opening area ratio: 56%)

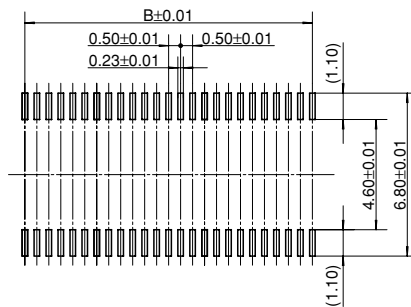

Recommended metal mask pattern
Metal mask thickness: Here, 120 μm
(Opening area ratio: 69%)

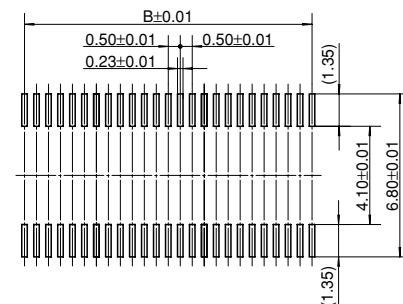

• P5K Header

Recommended PC board pattern (TOP VIEW)

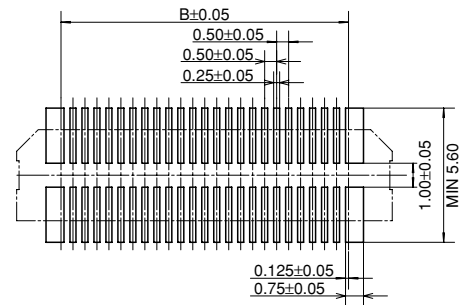

Recommended metal mask pattern
Metal mask thickness: Here, 150 μm
(Opening area ratio: 62%)

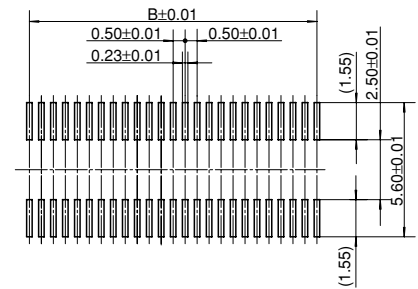

Recommended metal mask pattern
Metal mask thickness: Here, 120 μm
(Opening area ratio: 78%)

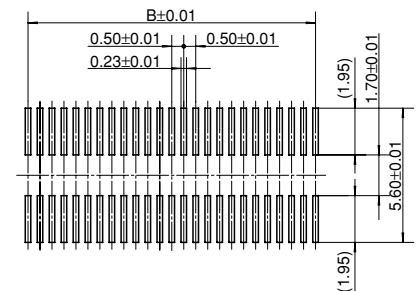

* See the dimension table on page 70 for more information on the B dimension of the socket and header.

P5KS: Mated height 4.0mm, 4.5mm, 5.0mm, 5.5mm, 6.0mm, 6.5mm, 7.0mm, 8.0mm, 9.0mm type

• Socket

Recommended PC board pattern
(TOP VIEW)

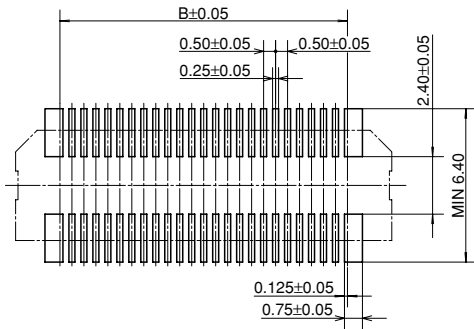

Recommended metal mask pattern
Metal mask thickness: Here, 150 μm
(Opening area ratio: 60%)

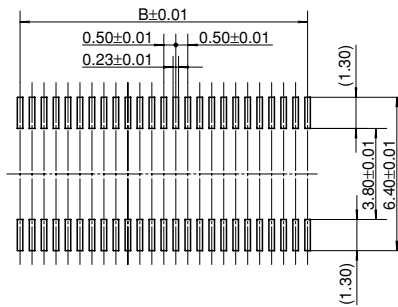

Recommended metal mask pattern
Metal mask thickness: Here, 120 μm
(Opening area ratio: 76%)

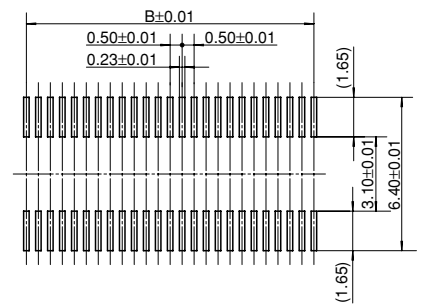

* See the dimension table on page 71 for more information on the B dimension.

• Header

Recommended PC board pattern
(TOP VIEW)

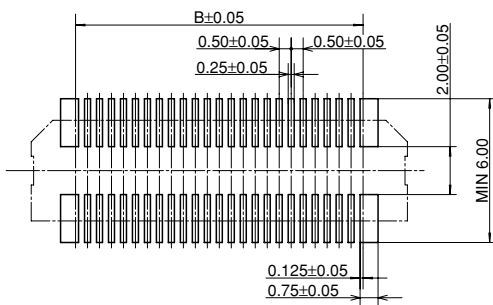

Recommended metal mask pattern
Metal mask thickness: Here, 150 μm
(Opening area ratio: 69%)

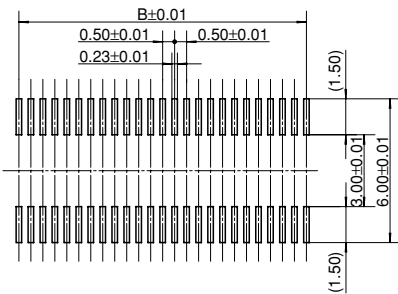

Recommended metal mask pattern
Metal mask thickness: Here, 120 μm
(Opening area ratio: 87%)

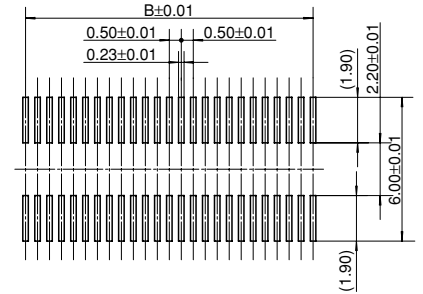

* See the dimension table on page 71 for more information on the B dimension.

P5KS: Mated height 4.0mm, 4.5mm for 120 contacts and 160 contacts types, 6.5mm for 130 contacts type

• Socket

Recommended PC board pattern
(TOP VIEW)

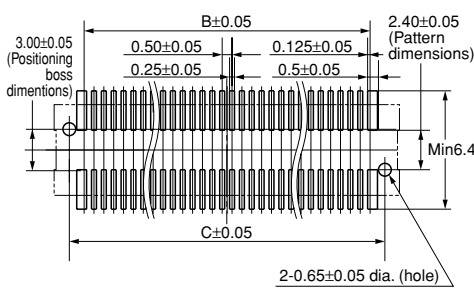

Recommended metal mask pattern
Metal mask thickness: Here, 150 μm
(Opening area ratio: 60%)

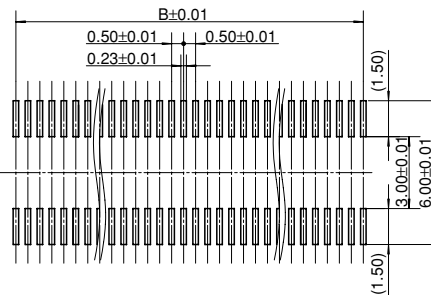

Recommended metal mask pattern
Metal mask thickness: Here, 120 μm
(Opening area ratio: 76%)

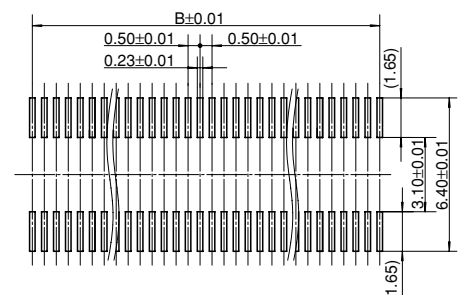

* See the dimension table on page 72 for more information on the B and C dimensions.

• Header

Recommended PC board pattern
(TOP VIEW)

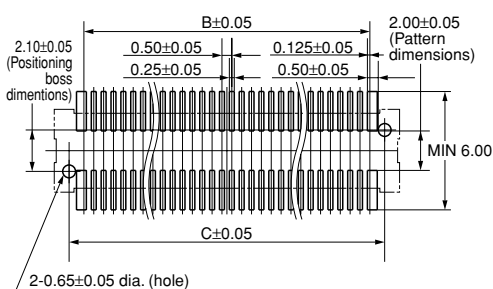

Recommended metal mask pattern
Metal mask thickness: Here, 150 μm
(Opening area ratio: 69%)

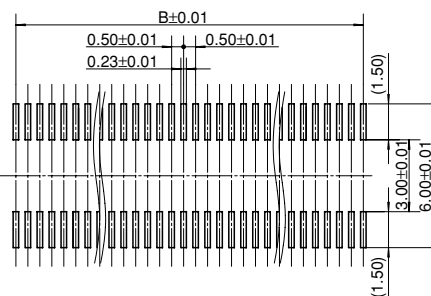

Recommended metal mask pattern
Metal mask thickness: Here, 120 μm
(Opening area ratio: 87%)

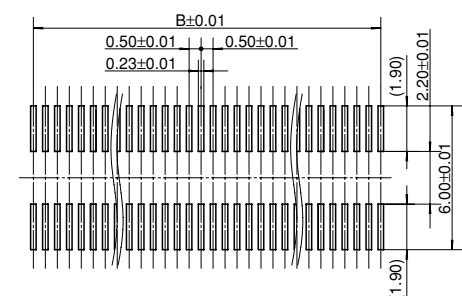

* See the dimension table on page 72 for more information on the B and C dimensions.

Regarding general notes, please refer to page 12.

For other details, please verify with the product specification sheets.